

The logo for Microtips Technology features a stylized graphic of vertical bars in red, green, and blue on the left, followed by the word "Microtips" in a large, bold, serif font. Below this, a thick horizontal line separates the word "TECHNOLOGY" from the rest of the page, with the letters in a bold, spaced-out, serif font.

# Microtips

---

## TECHNOLOGY

Model No: P011FZ00PPEE

Approved By	

Tel: 1 (888) 499-8477

Fax: (407) 273-0771

E-mail: [mtusainfo@microtipsusa.com](mailto:mtusainfo@microtipsusa.com)

Web: [www.microtipsusa.com](http://www.microtipsusa.com)

## RECORD OF REVISION

Version	Revised Date	Page	Content
V1.0	2018/03/21	--	First Issued

## TABLE OF CONTENTS

No.	Content	Page
	HDMI TFT Module Specification .....	1
	TABLE OF CONTENTS .....	3
1.	GENERAL DESCRIPTION .....	4
2.	MECHANICAL SPECIFICATION .....	5
3.	PIN DESCRIPTION .....	6
4.	ABSOLUTE MAXIMUM RATINGS .....	8
5.	BLOCK DIAGRAM .....	9
6.	ELECTRICAL CHARACTERISTICS .....	10
7.	OPTICAL CHARACTERISTICS .....	11
8.	RELIABILITY.....	14
9.	PRECAUTION RELATING PRODUCT HANDLING .....	19

## 1. GENERAL DESCRIPTION

### 1.1 Description

HA-101ZIEB0HH0-A is a 10.1 (16:10) inch diagonally measured active display with high resolution WXGA 1280x800 display and high brightness. This model is composed of a TFT LCD panel, backlight system and HDMI included Stereo D/A Converter . It is designed to make Raspberry Pi usage easy. You can simply use this TFT display with your Raspberry Pi, or also you can use this as computer display with any device which has HDMI output. This 10.1" TFT model comes in 1280x800 resolution that would be great for embedded computing usage too.

### 1.2 Features:

No.	Item	Specification	Unit
1	Panel Size	10.1"	Inch
2	Number of Pixels	1280 (W) x RGB x 800 (H)	Pixels
3	Active Area	216.96 (W) × 135.6 (H)	mm
4	Pixel Pitch	0.1695 (W) x 0.1695 (H)	mm
5	Outline Dimension	229.46 (W) × 149.1 (H) × 20.6 (T)	mm
6	Number of Colors	16.7M	- -
7	Display Mode	IPS / Normally Black / Transmissive	- -
8	View Direction	Free direction	- -
9	Display Format	RGB vertical stripe	- -
10	Surface Treatment	HC	- -
11	Contrast Ratio	800 (Typ.)	- -
12	Luminance (cd/m <sup>2</sup> )	600 (Typ.)	cd/m <sup>2</sup>
13	Video Input Interface	HDMI (Compliance HDMI V1.4 and include HDCP decryption)	- -
14	Audio Output Interface	Analog Output	- -
15	Backlight	White LED	- -
16	Operation Temperature	-20 ~ 70	°C
17	Storage Temperature	-30 ~ 80	°C
18	Weight	(TBD)	g



### 3. PIN DESCRIPTION

#### 3.1 Power Input(CN1) [DC JACK:SCD480CCS000B00GE or compatible]

Pin No.	Symbol	I/O	Function	Note
1	12V	P	Power Supply +12V	12.0V 
2	GND	P	Ground	

#### 3.2 Back-light Control(CN2) [WAFER P2.0mm:2001S-03-RTE or compatible]

Pin No.	Symbol	I/O	Function	Note
1	GND	P	Ground	
2	PWM	I	Back-light Dimming control (internal pull up to 3.3V)	*1
3	LED_EN	I	No connection. ( internal control)	

\*1: When PWM, LED\_EN not connected, back-light default is typical brightness.

#### 3.3 Audio line out(CN3) [WAFER P2.0mm:2001S-03-RTE or compatible]

Pin No.	Symbol	I/O	Function	Note
1	R_CH	A	HDMI Audio:Right Channel Analog Output	
2	GND	P	Ground	
3	L_CH	A	HDMI Audio:Left Channel Analog Output	

#### 3.4 Standard 3.5mm Phone Jack (CN4) [PHONE JACK:ST-301E or compatible]

HDMI Audio Analog Output

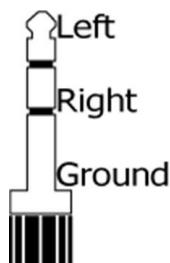

### 3.5 HDMI (CN5)

[HDMI A TYPE:PHD0911A2301E or compatible]

Pin No.	Symbol	I/O	Function	Note
1	TMDS 2+	I	TMDS Data2+	
2	GND	P	TMDS Data2 Shield	
3	TMDS 2-	I	TMDS Data2-	
4	TMDS 1+	I	TMDS Data1+	
5	GND	P	TMDS Data1 Shield	
6	TMDS 1-	I	TMDS Data1-	
7	TMDS 0+	I	TMDS Data0+	
8	GND	P	TMDS Data0 Shield	
9	TMDS 0-	I	TMDS Data0-	
10	TMDS CLK+	I	TMDS Clock+	
11	GND	P	TMDS Clock Shield	
12	TMDS CLK-	I	TMDS Clock-	
13	CEC	I	CEC	
14	N.C.	-	N.C.	
15	DDC_SCL	I	IIC SCL to EDID ROM	
16	DDC_SDA	I/O	IIC SDA to EDID ROM	
17	GND	P	DDC/CEC Ground	
18	HD_5V	P	+5V Power	
19	HPD	O	Hot Plug Detect	

#### 4. ABSOLUTE MAXIMUM RATINGS

##### 4.1 Electrical Absolute Rating

##### 4.1.1 HDMI TFT LCD Module

Item	Symbol	Values		Unit	Note
		Min	Max.		
Power supply voltage	12V	TBD	14	V	

##### 4.1.2 Environment Absolute Rating

Item	Symbol	Values			Unit	Note
		Min	Typ	Max.		
Operating Temperature	Top	-20		70	°C	Ambient temperature
Storage Temperature	Tst	-30		80	°C	



5. BLOCK DIAGRAM

5.1 TFT LCD Module

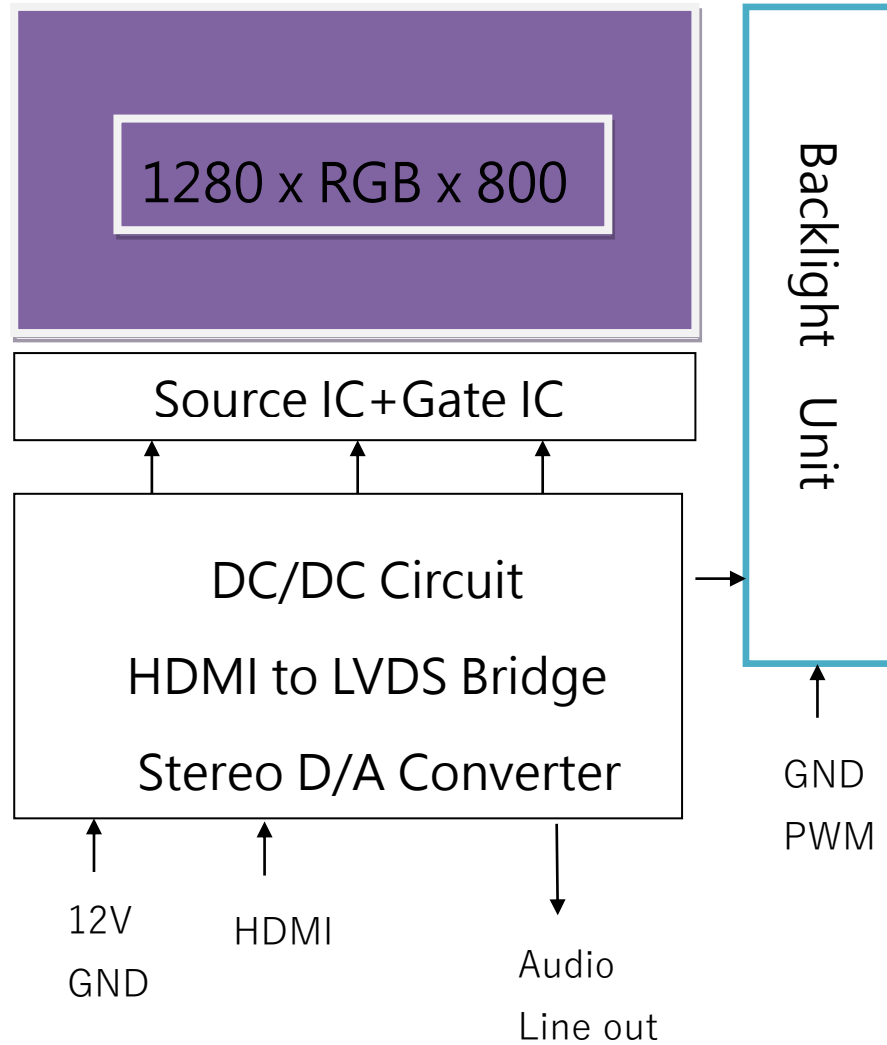

## 6. ELECTRICAL CHARACTERISTICS

### 6.1 HDMI TFT LCD Module

Item	Symbol	Values			Unit	Note
		Min	Typ.	Max.		
Supply Voltage	12V	TBD	12	13	V	
PWM frequency		100	-	10K	Hz	
PWM Duty		17	-	100	%	<17%=OFF
PWM Dimming Voltage	V <sub>PWM-IH</sub>	3.3	-	8	V	
	V <sub>PWM-IL</sub>	-	0.3	-	V	
LED Enable Control Voltage	V <sub>LED_EN-IH</sub>	3.3	-	12	V	
	V <sub>LED_EN-IL</sub>	-	-	0.5	V	
Supply Current	ICC(12V)	TBD	TBD	TBD	mA	
LED life time		70000	-	-	Hr	(1)

Note 1:

The “LED life time” is defined as the module brightness decrease to 50% original brightness that the ambient temperature is 25°C 60% RH.

## 7. OPTICAL CHARACTERISTICS

Item	Symbol	Condition	Min.	Typ.	Max.	Unit
Brightness	--	Note1, Note 3, ( $\theta = 0^\circ$ ; Normal Viewing Angle)	480	600	--	cd/m <sup>2</sup>
Uniformity	B-uni		75	80	-	%
Contrast Ratio	CR		600	800	--	--
Response Time	Tr		--	10	20	ms
	Tf		--	15	30	ms
Color Chromaticity	White	Wx	0.260	0.310	0.360	--
		Wy	0.280	0.330	0.380	--
View angle	Horizontal	$\theta_{x+}$	75	85	--	
		$\theta_{x-}$	75	85	--	
	Vertical	$\theta_{Y+}$	75	85	--	
		$\theta_{Y-}$	75	85	--	

Note : The following optical specifications shall be measured in a darkroom or equivalent state (ambient luminance  $\leq 1$  lux, and at room temperature). The operation temperature is  $25^\circ\text{C} \pm 2^\circ\text{C}$ . The measurement method is shown in Note1.

Note1: The method of optical measurement:

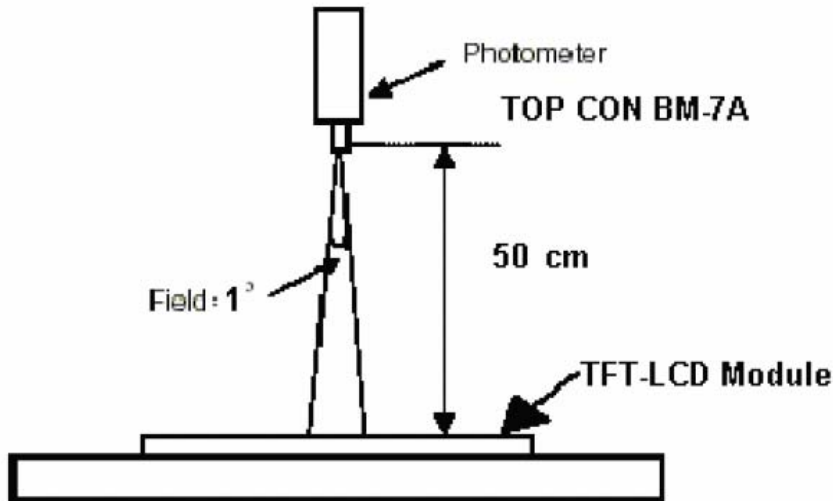

Note2: Measured at the center area of the panel and at the viewing angle of the  $\theta_x = \theta_y = 0^\circ$

Note3: Definition of Contrast Ratio (CR):

CR = Luminance with all pixels in white state  $\div$  Luminance with all pixels in Black state

Note 4: Definition of Viewing Angle:

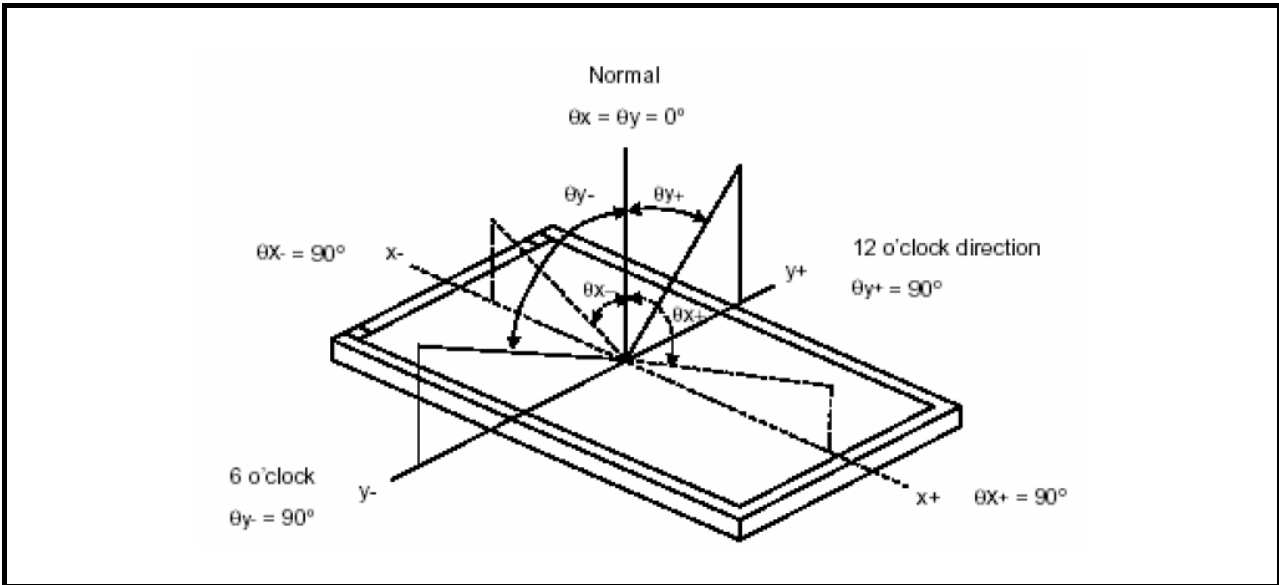

Note 5: Definition of Brightness Uniformity (B-uni):

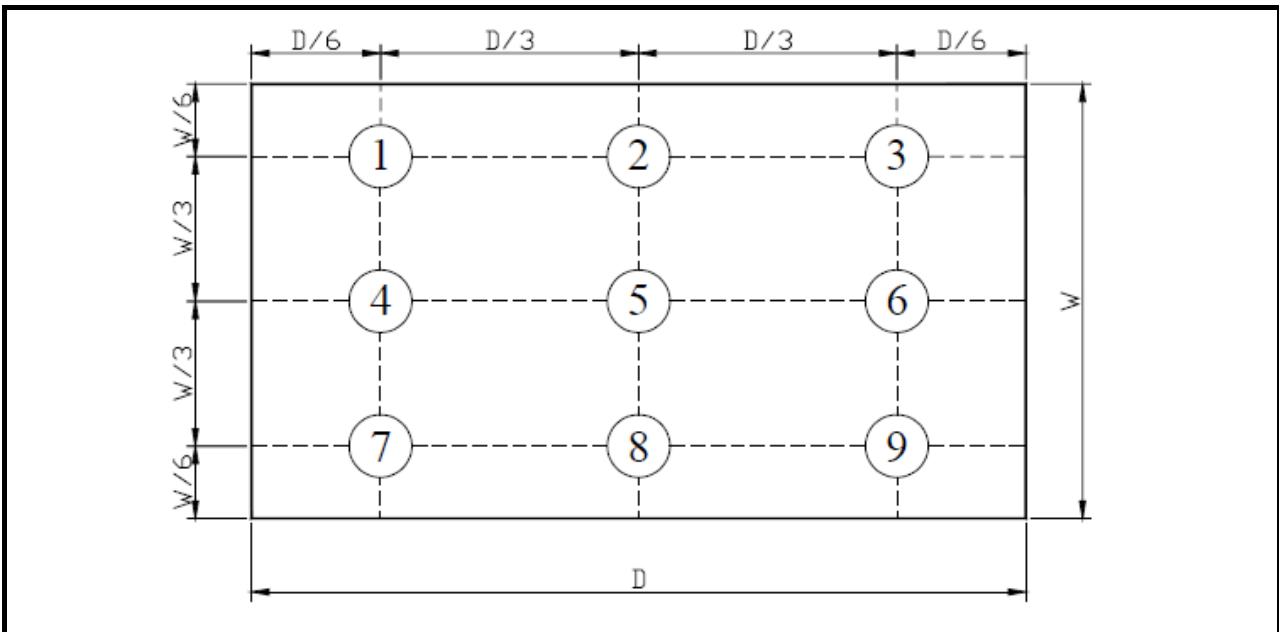

$B\text{-uni} = (\text{Minimum luminance of 9 points} \div \text{Maximum luminance of 9 points}) \times 100\%$

**Note 6: Definition of Response Time:**

The Response Time is set initially by defining the “Rising Time ( $T_r$ )” and the “Falling Time ( $T_f$ )” respectively.  $T_r$  and  $T_f$  are defined as following figure

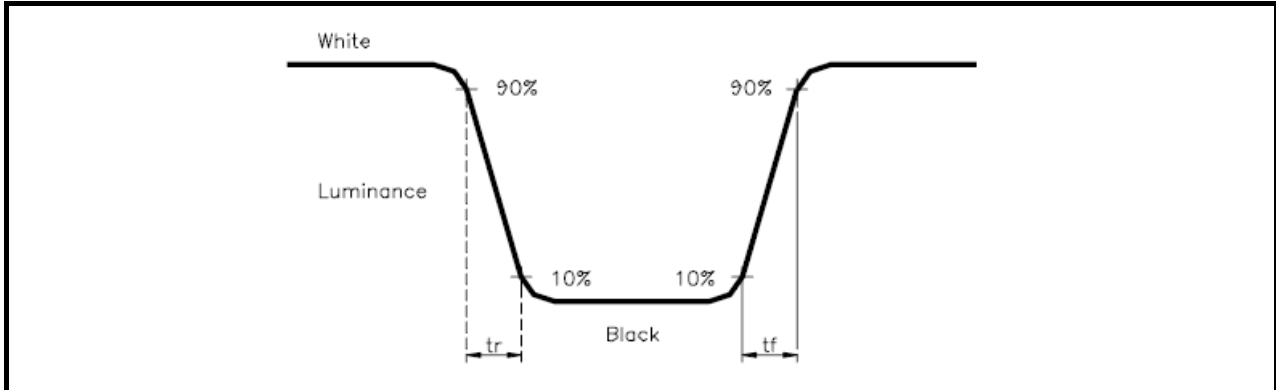

**Note 7: Definition of Chromaticity:**

The color coordinates ( $W_x, W_y$ ), ( $R_x, R_y$ ), ( $G_x, G_y$ ), and ( $B_x, B_y$ ) are obtained with all pixels in the viewing field at white, red, green, and blue states, respectively.

## 8. RELIABILITY

### 8.1 Test Condition

#### 8.1.1 Temperature and Humidity(Ambient Temperature)

Temperature :  $25 \pm 5^{\circ}\text{C}$

Humidity :  $65 \pm 5\%$

#### 8.1.2 Operation

Unless specified otherwise, test will be conducted under function state.

#### 8.1.3 Container

Unless specified otherwise, vibration test will be conducted to the product itself without putting it in a container.

#### 8.1.4 Test Frequency

In case of related to deterioration such as shock test. It will be conducted only once.

### 8.2 TESTS

No.	ITEM	CONDITION CRITERION
1	High Temperature Storage	80°C, 120 hrs
2	Low Temperature Storage	-30°C, 120 hrs
3	High Temperature Operating	70°C, 120 hrs
4	Low Temperature Operating	-20°C, 120 hrs
5	High Temperature/Humidity Non-Operating	40°C, 90%RH, 120 hrs
6	Temperature Shock Non-Operating	-30°C $\leftrightarrow$ 80°C (0.5hr each), 100 cycles
7	Vibration Test Non-Operating	Frequency:0 ~ 55 Hz Amplitude:1.5 mm Sweep Time:11min Test Period:6 Cycles for each Direction of X,Y,Z
8	Electro-static Discharge	$\pm$ 2KV, Human Body Mode, 100pF/1500 $\Omega$

Note1: The test sample have recovery time for 24 hours at room temperature before the function check. In the standard conditions, there is no any touch panel function NG issue occurred.

### **8.3 JUDGMENT STANDARD**

The judgment of the above test should be made as follow:

Pass: Normal display image with no obvious non-uniformity and no line defect. Partial transformation of the module parts should be ignored.

Fail: No display image, obvious non-uniformity, or line defects.

### 8.4 INCOMING INSPECTION STANDARDS

No.	Parameter	Criteria									
1	Operating	Display function: No Display malfunction (Major)									
		Contrast ratio (Black, White): Does not meet specified range in the spec. (Major) (Note:3)									
		Line Defect: No obvious Vertical and Horizontal line defect in bright, dark and colored. (Major) (Note:1)									
		Point Defect : Active area $\leq 5$ dots (Minor) (Note:1)									
		<table border="1"> <thead> <tr> <th rowspan="2">Item</th> <th>Acceptable number</th> <th rowspan="2">Total</th> </tr> <tr> <th>Active Area</th> </tr> </thead> <tbody> <tr> <td>Bright</td> <td>2</td> <td rowspan="2">5</td> </tr> <tr> <td>Dark</td> <td>4</td> </tr> </tbody> </table>	Item	Acceptable number	Total	Active Area	Bright	2	5	Dark	4
		Item		Acceptable number		Total					
Active Area											
Bright	2	5									
Dark	4										
Non-uniformity: Visible through 5%ND filter. (Minor)											
Foreign material in Black or White spots shape ( $W > 1/4L$ )											
<table border="1"> <thead> <tr> <th>Zone Dimension</th> <th>Acceptable number</th> <th rowspan="4">Class Of Defects</th> <th rowspan="4">AQL Level</th> </tr> </thead> <tbody> <tr> <td><math>D &gt; 0.5</math></td> <td>0</td> </tr> <tr> <td><math>0.3 &lt; D \leq 0.5</math></td> <td>5</td> </tr> <tr> <td><math>D \leq 0.3</math></td> <td>*</td> </tr> </tbody> </table> <p><math>D = (\text{Long} + \text{Short}) / 2</math> * : Disregard</p>	Zone Dimension	Acceptable number	Class Of Defects	AQL Level	$D > 0.5$	0	$0.3 < D \leq 0.5$	5	$D \leq 0.3$	*	
Zone Dimension	Acceptable number	Class Of Defects			AQL Level						
$D > 0.5$	0										
$0.3 < D \leq 0.5$	5										
$D \leq 0.3$	*										
Foreign Material in Line or spiral shape ( $W \leq 1/4L$ ) (Note: 4)											
<table border="1"> <thead> <tr> <th>L (mm) \ Zone W(mm)</th> <th>Acceptable number</th> <th rowspan="4">Class Of Defects</th> <th rowspan="4">AQL Level</th> </tr> </thead> <tbody> <tr> <td><math>L &gt; 5</math>    <math>W &gt; 0.1</math></td> <td>0</td> </tr> <tr> <td><math>0.5 &lt; L \leq 5</math>    <math>0.03 &lt; W \leq 0.1</math></td> <td>5</td> </tr> <tr> <td><math>L \leq 0.5</math>    <math>W \leq 0.03</math></td> <td>*</td> </tr> </tbody> </table> <p>L : Length    W : Width    * : Disregard</p>	L (mm) \ Zone W(mm)	Acceptable number	Class Of Defects	AQL Level	$L > 5$ $W > 0.1$	0	$0.5 < L \leq 5$ $0.03 < W \leq 0.1$	5	$L \leq 0.5$ $W \leq 0.03$	*	
L (mm) \ Zone W(mm)	Acceptable number	Class Of Defects			AQL Level						
$L > 5$ $W > 0.1$	0										
$0.5 < L \leq 5$ $0.03 < W \leq 0.1$	5										
$L \leq 0.5$ $W \leq 0.03$	*										
2	External Inspection (non-operating)	Dimension: Outline (Major)									
		Bezel appearance: uneven (Minor)									
		Scratch on the polarize: (Note:2)									
		<table border="1"> <thead> <tr> <th>L (mm) \ Zone W(mm)</th> <th>Acceptable number</th> <th rowspan="3">Class Of Defects</th> <th rowspan="3">AQL Level</th> </tr> </thead> <tbody> <tr> <td>--    <math>W &gt; 0.1</math></td> <td>0</td> </tr> <tr> <td><math>L \leq 3</math>    <math>W \leq 0.1</math></td> <td>3</td> </tr> </tbody> </table> <p>L : Length    W : Width    * : Disregard</p>	L (mm) \ Zone W(mm)	Acceptable number	Class Of Defects	AQL Level	-- $W > 0.1$	0	$L \leq 3$ $W \leq 0.1$	3	
		L (mm) \ Zone W(mm)	Acceptable number	Class Of Defects			AQL Level				
		-- $W > 0.1$	0								
$L \leq 3$ $W \leq 0.1$	3										
Dent or bubble on the polarize (Note:2)											
<table border="1"> <thead> <tr> <th>Zone Dimension</th> <th>Acceptable number</th> <th rowspan="3">Class Of Defects</th> <th rowspan="3">AQL Level</th> </tr> </thead> <tbody> <tr> <td><math>D \leq 0.3</math></td> <td>*</td> </tr> <tr> <td><math>D \leq 0.5</math></td> <td>3</td> </tr> </tbody> </table> <p><math>D = (\text{Long} + \text{Short}) / 2</math>    * : Disregard</p>	Zone Dimension	Acceptable number	Class Of Defects	AQL Level	$D \leq 0.3$	*	$D \leq 0.5$	3			
Zone Dimension	Acceptable number	Class Of Defects			AQL Level						
$D \leq 0.3$	*										
$D \leq 0.5$	3										



Class of defects	Major	AQL 0.65%	Definition
	Minor	AQL 1.5%	It is a defect that will not result in functioning problem with deviation classified.

**Note1:**

- (a) Bright point defect is defined as point defect of R,G,B with area  $>1/2$  pixel respectively
- (b) Dark point defect is defined as visible in full white pattern.
- (c) Definition of distribution of point defect is as follows:
  - minimum separation between dark point defects should be larger than 5mm.
  - minimum separation between bright point defects should be larger than 5mm.
- (d) Definition of joined bright point defect and joined dark point defect are as follows:
  - Two or more joined bright point defects must be nil.
  - Three joined dark point defects must be nil.
  - Coupling of one dark and one bright point in junction is counted as one dark and bright spot with 1 pair maximum.
  - Two Joined dark point is counted as two dark points with 2 pair maximum.

Note2: The external inspection should be conducted at the distance  $30 \pm 5$ cm between the eyes of inspector and the panel.

Note3: Luminance measurement for contrast ratio is at the distance  $50 \pm 5$ cm between the detective head and the panel with ambient luminance less than 1 lux. Contrast ratio is obtained at optimum view angle.

Note4: W-Width in mm , L-length of Max.(L1,L2) in mm.

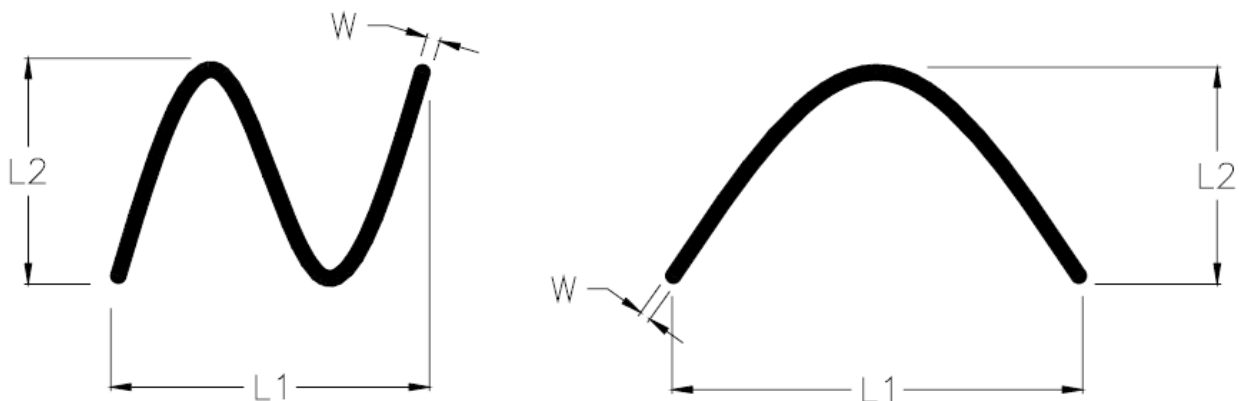

### 8.5 Sampling Condition

Unless otherwise agree in written, the sampling inspection shall be applied to the incoming inspection of customer.

Lot size: Quantity of shipment lot per model.

Sampling type: normal inspection, single sampling

Sampling table: MIL-STD-105E

Inspection level: Level II

### 8.6 Inspection conditions

The LCD shall be inspected under 40W white fluorescent light.

$\theta \leq 45^\circ$  inspection under non-operating condition.

$\theta \leq 5^\circ$  inspection under operating condition

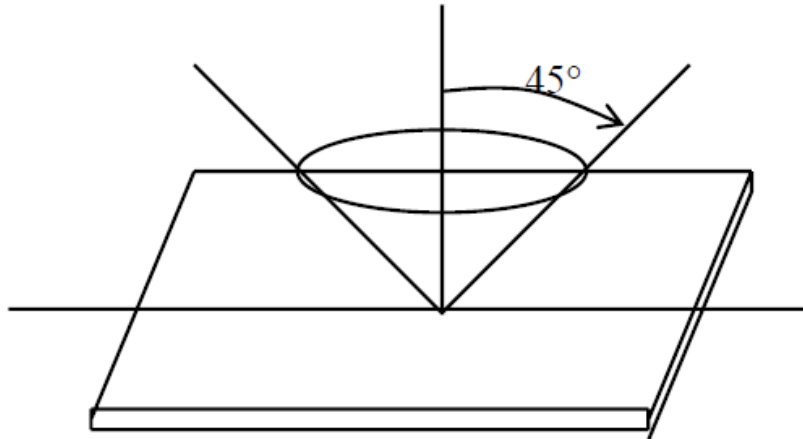

## **9. PRECAUTION RELATING PRODUCT HANDLING**

### **9.1 SAFETY**

- 9.1.1 If the LCD panel breaks , be careful not to get the liquid crystal to touch your skin.**
- 9.1.2 If the liquid crystal touches your skin or clothes , please wash it off immediately by using soap and water.**

### **9.2 HANDLING**

- 9.2.1 Avoid any strong mechanical shock which can break the glass.**
- 9.2.2 Avoid static electricity which can damage the CMOS LSI—When working with the module, be sure to ground your body and any electrical equipment you may be using.**
- 9.2.3 Do not remove the panel or frame from the module.**
- 9.2.4 The polarizing plate of the display is very fragile. So , please handle it very carefully, Do not touch, push or rub the exposed polarizing with anything harder than an HB pencil lead (glass , tweezers , etc.)**
- 9.2.5 Do not wipe the polarizing plate with a dry cloth, as it may easily scratch the surface of plate.**
- 9.2.6 Do not touch the display area with bare hands , this will stain the display area.**
- 9.2.7 Do not use ketonics solvent & aromatic solvent. Use with a soft cloth soaked with a cleaning naphtha solvent.**
- 9.2.8 To control temperature and time of soldering is  $280 \pm 10^{\circ}\text{C}$  and 3-5 sec.**
- 9.2.9 To avoid liquid (include organic solvent) stained on LCM.**

### **9.3 STORAGE**

- 9.3.1 Store the panel or module in a dark place where the temperature is  $25^{\circ}\text{C} \pm 5^{\circ}\text{C}$  and the humidity is below 65% RH.**
- 9.3.2 Do not place the module near organics solvents or corrosive gases.**
- 9.3.3 Do not crush, shake, or jolt the module.**



Компания «ЭлектроПласт» предлагает заключение долгосрочных отношений при поставках импортных электронных компонентов на взаимовыгодных условиях!

Наши преимущества:

- Оперативные поставки широкого спектра электронных компонентов отечественного и импортного производства напрямую от производителей и с крупнейших мировых складов;
- Поставка более 17-ти миллионов наименований электронных компонентов;
- Поставка сложных, дефицитных, либо снятых с производства позиций;
- Оперативные сроки поставки под заказ (от 5 рабочих дней);
- Экспресс доставка в любую точку России;
- Техническая поддержка проекта, помощь в подборе аналогов, поставка прототипов;
- Система менеджмента качества сертифицирована по Международному стандарту ISO 9001;
- Лицензия ФСБ на осуществление работ с использованием сведений, составляющих государственную тайну;
- Поставка специализированных компонентов (Xilinx, Altera, Analog Devices, Intersil, Interpoint, Microsemi, Aeroflex, Peregrine, Syfer, Eurofarad, Texas Instrument, Miteq, Cobham, E2V, MA-COM, Hittite, Mini-Circuits, General Dynamics и др.);

Помимо этого, одним из направлений компании «ЭлектроПласт» является направление «Источники питания». Мы предлагаем Вам помощь Конструкторского отдела:

- Подбор оптимального решения, техническое обоснование при выборе компонента;
- Подбор аналогов;
- Консультации по применению компонента;
- Поставка образцов и прототипов;
- Техническая поддержка проекта;
- Защита от снятия компонента с производства.



#### Как с нами связаться

**Телефон:** 8 (812) 309 58 32 (многоканальный)

**Факс:** 8 (812) 320-02-42

**Электронная почта:** [org@eplast1.ru](mailto:org@eplast1.ru)

**Адрес:** 198099, г. Санкт-Петербург, ул. Калинина, дом 2, корпус 4, литера А.