

# FTDI Chip

## VM800BU Datasheet

### Embedded Video Engine

### Basic USB module



*General Purpose Multi Media Controller*

## 1 Introduction

The VM800BU is a USB controlled development module for FTDI's FT800, which is used to develop and demonstrate the functionality of the FT800 Embedded Video Engine, EVE.

This module interfaces with a system controller via a USB port, accessing an on-board FT232H bridge chip to connect to the FT800 SPI port.

VM800BU modules support 3 different LCD panel size options and are designed for industrial or commercial environments with precision fitted bezels in either black (-BK) or pearl (-PL).

- VM800BU35A-xx is the 3.5" LCD
- VM800BU43A-xx is the 4.3" LCD
- VM800BU50A-xx is the 5.0" LCD

## 1.1 Features

The VM800BU utilises the FTDI FT800 Embedded Video Engine, EVE. Graphic, audio and touch features of the FT800 chip can be accessed with the VM800BU. For a full list of the FT800's features please see the [FT800 datasheet](#). The VM800BU has the following features:

- Integrated QVGA resolution (3.5") or WQVGA resolution (4.3"/5.0") LCD display
- Integrated resistive touch screen LCD panel
- On board LCD backlight LED Driver
- On board audio power amplifier and micro speaker
- FT232H USB interface controller
- Flexible 5V power supply. Powering the VM800BU using either a 2.1mm power jack or USB Micro-B port
- Precision fitted bezel in black(-BK) or pearl (-PL)

Neither the whole nor any part of the information contained in, or the product described in this manual, may be adapted or reproduced in any material or electronic form without the prior written consent of the copyright holder. This product and its documentation are supplied on an as-is basis and no warranty as to their suitability for any particular purpose is either made or implied. Future Technology Devices International Ltd will not accept any claim for damages howsoever arising as a result of use or failure of this product. Your statutory rights are not affected. This product or any variant of it is not intended for use in any medical appliance, device or system in which the failure of the product might reasonably be expected to result in personal injury. This document provides preliminary information that may be subject to change without notice. No freedom to use patents or other intellectual property rights is implied by the publication of this document. Future Technology Devices International Ltd, Unit 1, 2 Seaward Place, Centurion Business Park, Glasgow G41 1HH United Kingdom. Scotland Registered Company Number: SC136640

## 2 Ordering Information

<b>Part No.</b>	<b>Description</b>
VM800BU35A-BK	VM800BU module, 3.5 inch TFT LCD display panel preinstalled, black bezel
VM800BU43A-BK	VM800BU module, 4.3 inch TFT LCD display panel preinstalled, black bezel
VM800BU50A-BK	VM800BU module, 5.0 inch TFT LCD display panel preinstalled, black bezel
VM800BU35A-PL	VM800BU module, 3.5 inch TFT LCD display panel preinstalled, pearl bezel
VM800BU43A-PL	VM800BU module, 4.3 inch TFT LCD display panel preinstalled, pearl bezel
VM800BU50A-PL	VM800BU module, 5.0 inch TFT LCD display panel preinstalled, pearl bezel
VA-FC-1M-BKW	Accessory - Flat USB A to Micro B Cable 1M- Black and White
VA-FC-1M-BLW	Accessory - Flat USB A to Micro B Cable 1M- Blue and White
VA-FC-STYLUS1	Accessory - Resistive Touch Screen Pen Stylus

**Table 2-1 – Ordering information**

Note: 3.5" display resolution is 320 x 240 (QVGA).

4.3"/5.0" display resolution is 480 x 272 (WQVGA)

## **Table of Contents**

<b>1</b>	<b>Introduction .....</b>	<b>1</b>
1.1	Features.....	1
<b>2</b>	<b>Ordering Information .....</b>	<b>2</b>
<b>3</b>	<b>Hardware Description .....</b>	<b>4</b>
3.1	VM800BU module.....	4
3.2	Physical Descriptions .....	5
3.2.1	PCB layout.....	5
3.2.2	VM800BU Connectors.....	6
<b>4</b>	<b>Board Schematics.....</b>	<b>8</b>
<b>5</b>	<b>Hardware Setup Guide .....</b>	<b>11</b>
5.1	Power Configuration .....	11
5.2	MPSSE Setup.....	11
<b>6</b>	<b>Assembling the Bezel and Panel Mounting .....</b>	<b>13</b>
6.1	3.5" Dimensions.....	14
6.2	4.3" Dimensions.....	15
6.3	5.0" Dimensions.....	16
<b>7</b>	<b>Specifications.....</b>	<b>17</b>
7.1	Optical Specification .....	17
<b>8</b>	<b>Contact Information.....</b>	<b>19</b>
<b>Appendix A - References .....</b>		<b>20</b>
Document References .....		20
<b>Appendix B - List of Figures and Tables .....</b>		<b>21</b>
List of Figures .....		21
List of Tables.....		21
<b>Appendix C – Revision History .....</b>		<b>22</b>

### 3 Hardware Description

Please refer to section 3.2.2 for connector settings. Some VM800BU jumpers must be set to work properly with your system.

#### 3.1 VM800BU module



**Figure 3-1 - VM800BU module profile 3.5" display version**



**Figure 3-2 - VM800BU module profile 4.3" display version**



**Figure 3-3 - VM800BU module profile 5" display version**

NOTE: Also available in pearl.

The VM800BU module is intended for direct use into existing applications that require a display. This module is suitable for interfacing with a system that has a USB Host port.

The VM800BU module is available in multiple options: 3.5, 4.3 or 5.0 inch display options.

The main functions of the VM800BU are as follows:

- Micro USB connector
- 2-pin connector for power supply
- 3.3V regulator: Takes 5V input and outputs 3.3V for on-board circuits
- LCD touch screen panel
- 3 stage audio filter and power amplifier
- 8Ω speaker
- Audio line out option
- FT232H enabled USB to SPI Bridge
- Precision fitted bezel

## 3.2 Physical Descriptions

### 3.2.1 PCB layout

The VM800BU module PCB layouts are illustrated in Figure 3-4 and Figure 3-5. Boards are four-layer, approximately 1.6 mm thickness.

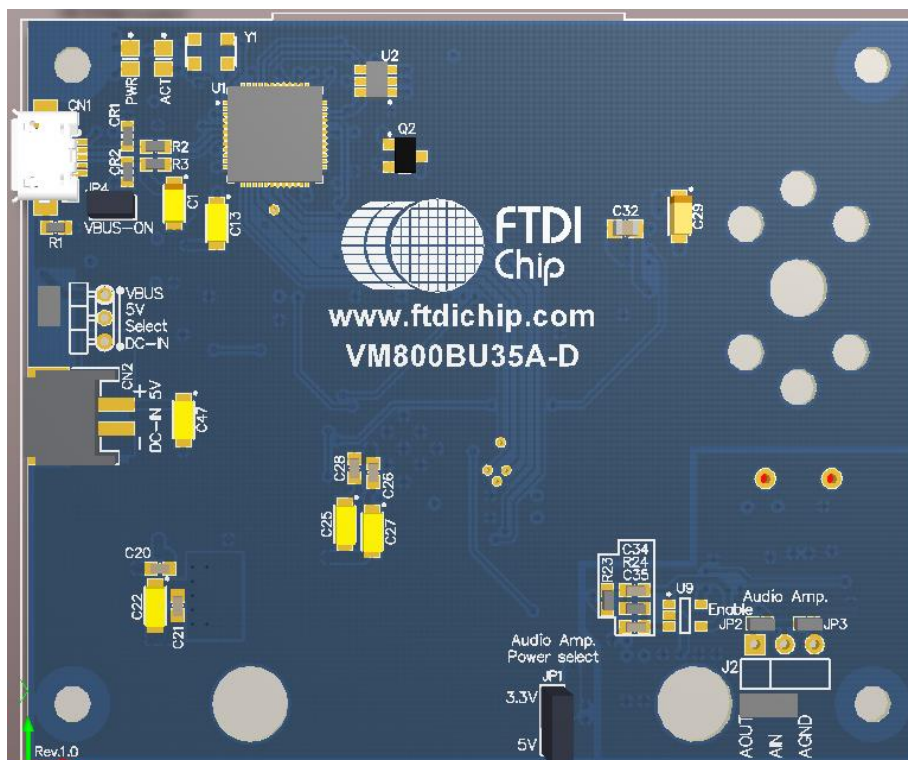

**Figure 3-4 - VM800BU module PCB view, 3.5" display version**



**Figure 3-5 - VM800BU module PCB view, 4.3" and 5" display version**

### 3.2.2 VM800BU Connectors

Connectors and jumpers are described in the following sections.

- **CN1- Micro USB Receptacle**

This receptacle is for 5V input to power the board. This also has USB functionality.

Pin No.	Name	Type	Description
1	VBUS	P	5V power supply
2	DM	IO	Connected to FT232HQ
3	DP	IO	Connected to FT232HQ
4	NC	NA	No connection
5	GND	P	Ground

**Table 3-1 – CN1 Pinout**

- **CN2- 2-pin power connector**

2 pin connector for 5V/3.3V power input to the board. Alternative to Micro USB connector.

Pin No.	Name	Type	Description
1	VCC	P	5V or 3.3V DC power supply
2	GND	P	Ground

**Table 3-2 – CN2 Pinout**

- **J2 - Selection between Lineout and loop back into the power amplifier.**

Selection between audio lineout and loop back into the power amplifier.

Jumper position	Description
Short pin 1-2	Audio amp enabled (default)

**Table 3-3 – J2 Pin Options**

- **JP1- Audio Amplifier Power Select**

This jumper provides the option to select the power supply voltage for the on-board power amplifier.

Jumper position	Description
Short pin 1-2	3.3V selected (default)
Short pin 2-3	5V selected

**Table 3-4 – JP1 Pin options**

\*This needs to be configured before audio can be heard. Default is 3.3V. Select 5V to increase the maximum volume for the speaker.

- **JP2 – On board amplifier enable**

Solder connection not fitted by default.

- **JP3 - On board amplifier mute**

Solder connection not fitted by default. Do not use.

- **JP4 – VBUS ON**

Jumper fitted by default.

- **SW1 – Power source select**

Jumper position	Description
Short pin 1-2	Board power from CN1 (default)
Short pin 2-3	Board power from CN2

**Table 3-5 – SW1 jumper options**



## 4 Board Schematics

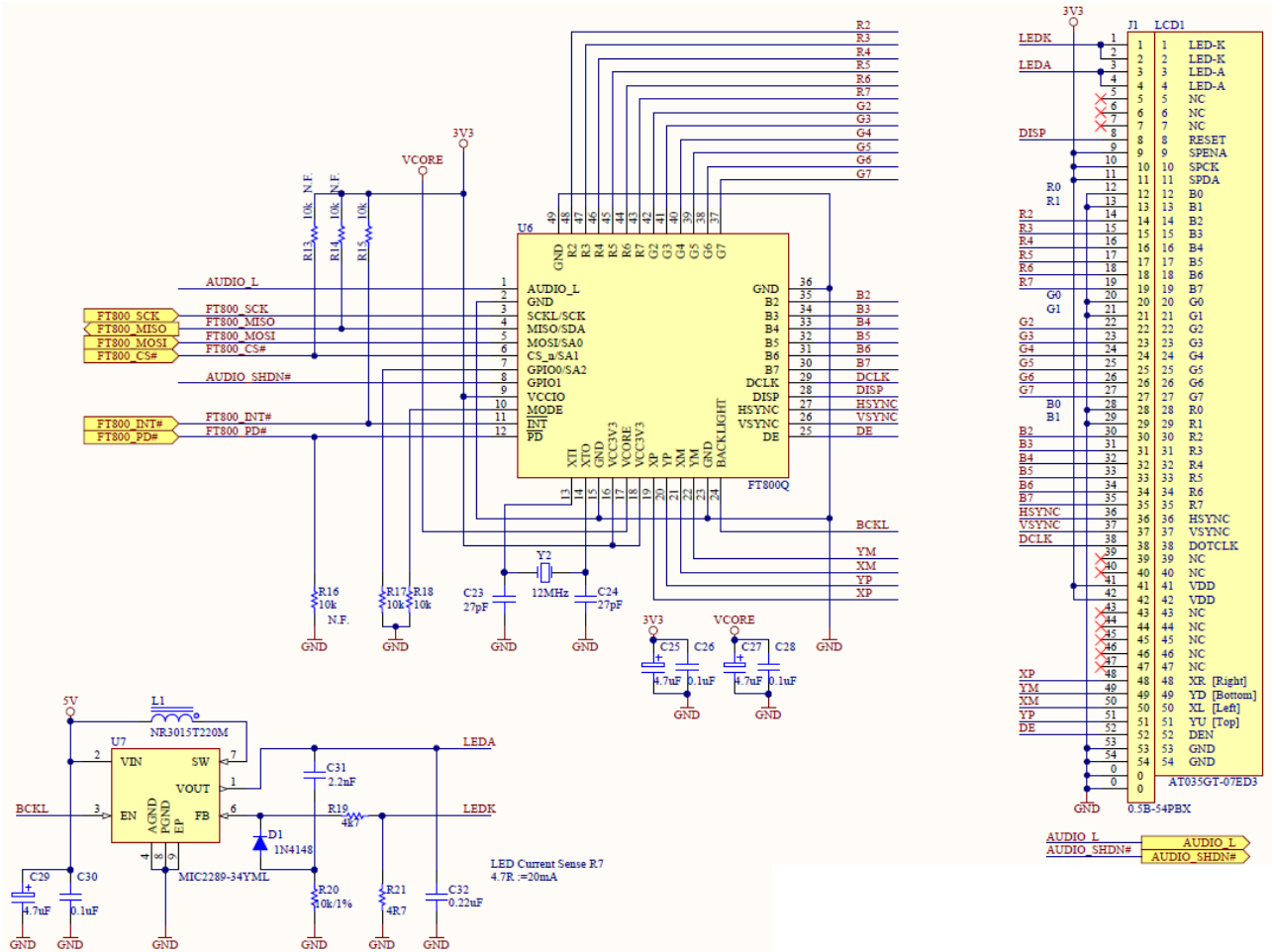
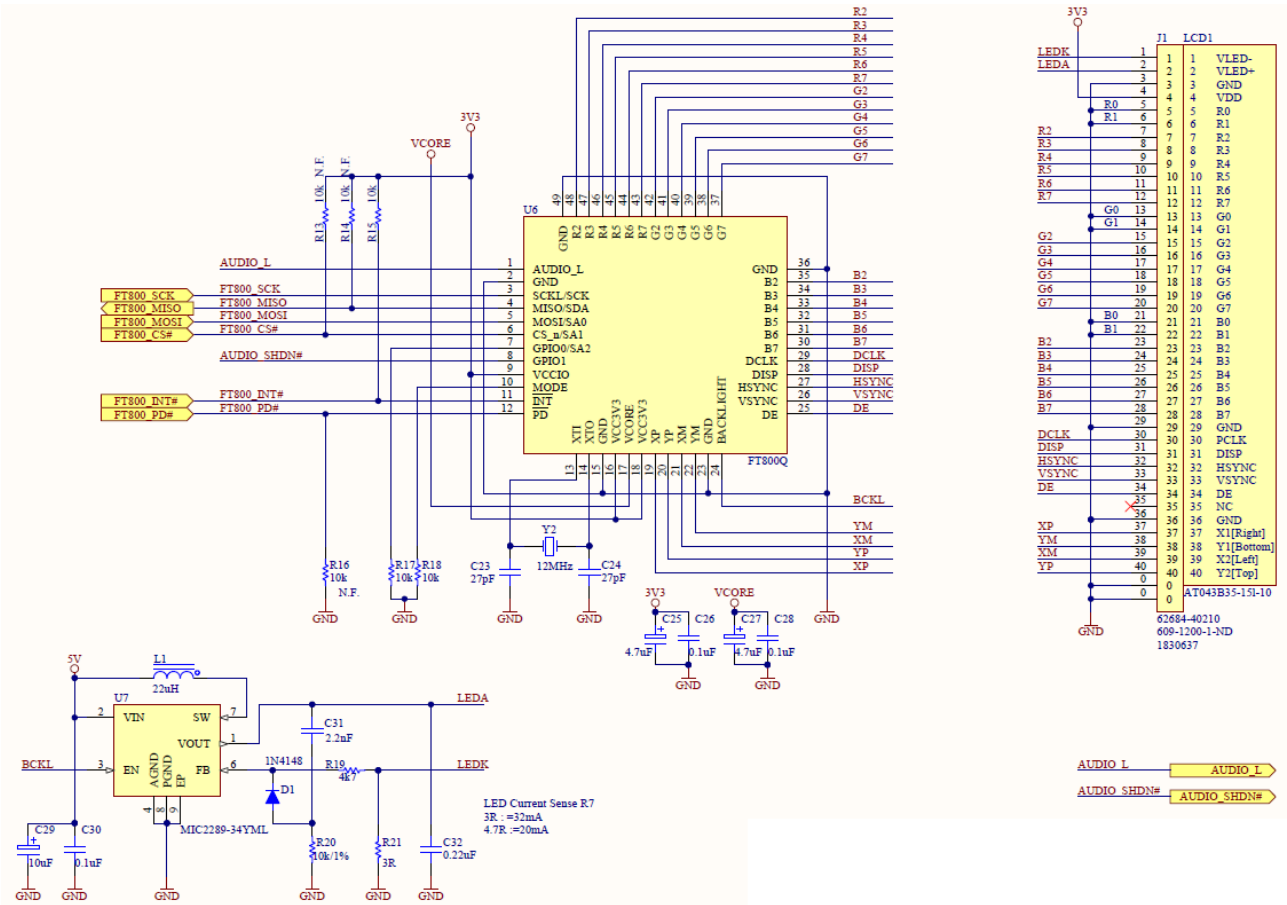
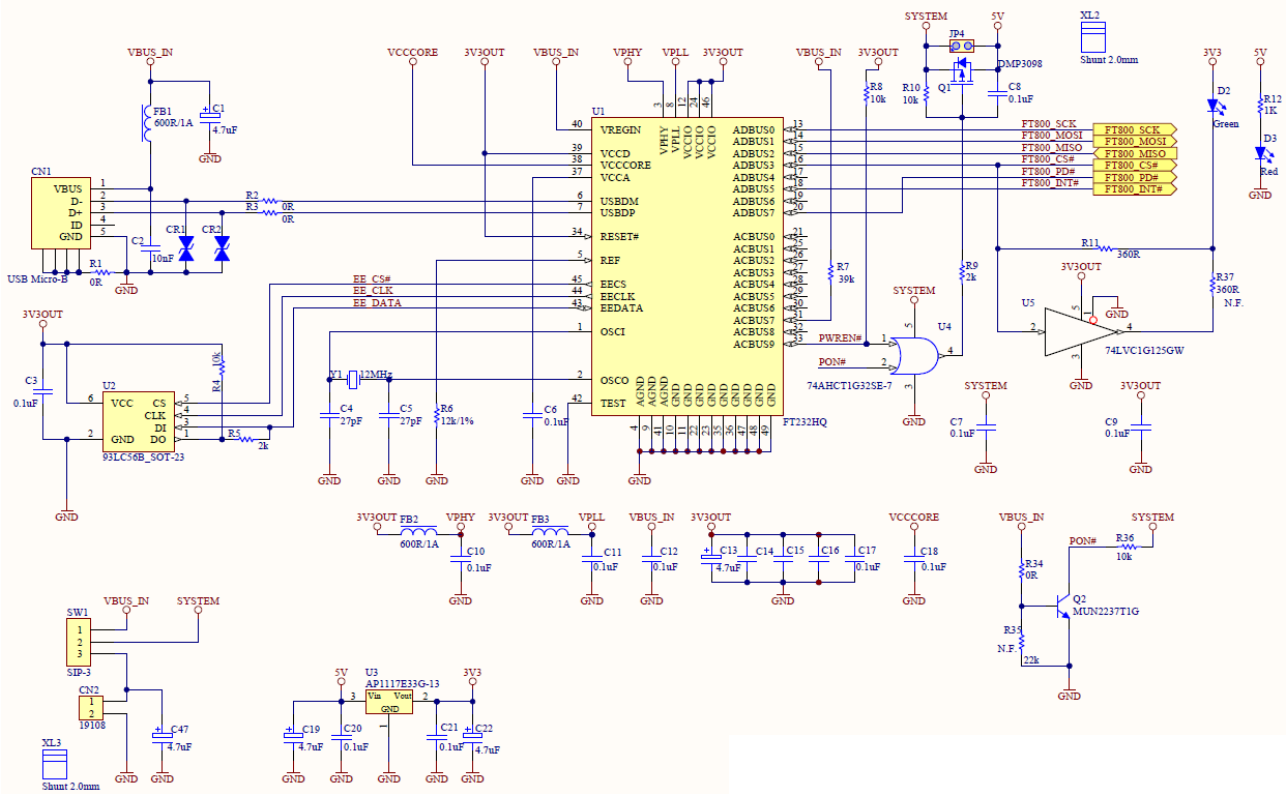

Figure 4-1 - VM800BU35A LCD Interface (3.5" Version)

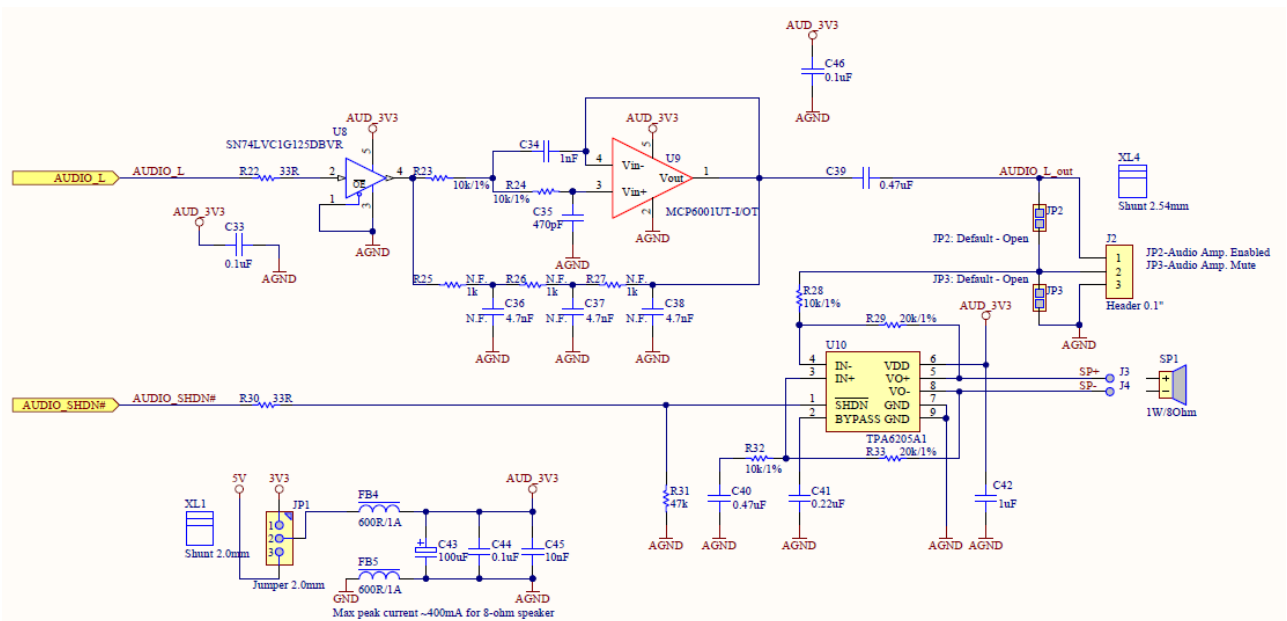



**Figure 4-2 - VM800BU43A/VM800BU50A LCD Interface (4.3"/5.0" Version)**



**Figure 4-3 – VM800BU SPI Interface and Power Input**



**Figure 4-4 – VM800BU Audio Circuits**

## 5 Hardware Setup Guide

### 5.1 Power Configuration

There are 2 methods of powering the VM800BU board.

- 1) USB Power(5V) - Connect USB power through micro-USB cable to CN1
- 2) DC IN(5V) - Connect 5V to CN2

The following table summarise how to power the VM800BU board using the various methods.

Power Method	CN1	CN2	SW1
USB Power	5V	N/C	Short pin 1-2
DC IN(5V)	N/C	5V	Short pin 2-3

**Table 5-1 - Board power configuration**

### 5.2 MPSSE Setup

To provide a quick start with the VM800BU development board, Windows based sample projects including source code are provided for users to get a touch and feel experience with the VM800BU. An overview of the process is provided in the following paragraphs with more details in [AN\\_245\\_VM800CB\\_SampleAPP\\_PC\\_Introduction](#).

MPSSE is a “multi-purpose synchronous serial engine” interface available in some FTDI devices (e.g. FT2232D, FT232H, FT2232H and FT4232H). This engine allows users to bridge from a USB port to an I<sup>2</sup>C or SPI interface. Sample code is available for driving the FT800 over this interface with a FT232H device.

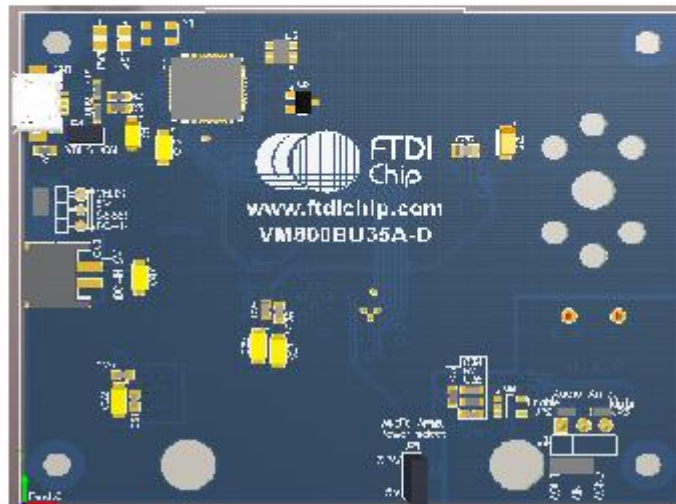

**Figure 5-1 – VM800BU Connects to PC through USB**

### **Hardware Setup**

- Connect a USB cable (suggest FTDI accessory **VA-FC-1M-BKW** or **VA-FC-1M-BLW**) from the VM800BU USB port to the PC USB host port or self-powered hub port.
- The PC or hub will supply power to the VM800BU.

### **Software Setup**

- Launch the demo application based on MPSSE from the PC.

The demo application notes can be found at following link:  
[AN\\_245\\_VM800CB\\_SampleAPP\\_PC\\_Introduction](#)

The demo application examples can be downloaded at following link:

[http://www.ftdichip.com/Support/SoftwareExamples/FT800\\_Projects.htm](http://www.ftdichip.com/Support/SoftwareExamples/FT800_Projects.htm)

## 6 Assembling the Bezel and Panel Mounting



**Figure 6-1 - VM800BU Panel Mount (Front view)**



**Figure 6-2 - VM800BU Panel Mount (Rear view)**

## 6.1 3.5" Dimensions

The TFT Touchscreen Mounting Frame is designed to mount to a 1.5mm thick Front Panel. If mounted to a Front Panel thicker than 1.5mm, longer mounting studs or screws should be used to accommodate the difference.

The Mounting Frame has been designed to work with projection welded studs or csk screws 'A' or press studs 'B'. For a 1.5mm thick Front Panel use -  
M3 x 8 long weld studs,  
M3 x 10 long countersunk screws or  
M3 x 10 long pressed studs



When using countersunk screws to assemble the Mounting Frame, the screws should be located at the 'A' position



**Figure 6-3 - VM800BU 3.5" panel mount dimensions**

## 6.2 4.3" Dimensions

The TFT Touchscreen Mounting Frame is designed to mount to a 1.5mm thick Front Panel. If mounted to a Front Panel thicker than 1.5mm, longer mounting studs or screws should be used to accommodate the difference.

The Mounting Frame has been designed to work with projection welded studs or csk screws 'A' or press studs 'B'. For a 1.5mm thick Front Panel use -  
M3 x 8 long weld studs,  
M3 x 10 long countersunk screws or  
M3 x 10 long pressed studs

When using countersunk screws to assemble the Mounting Frame, the screws should be located at the 'A' position

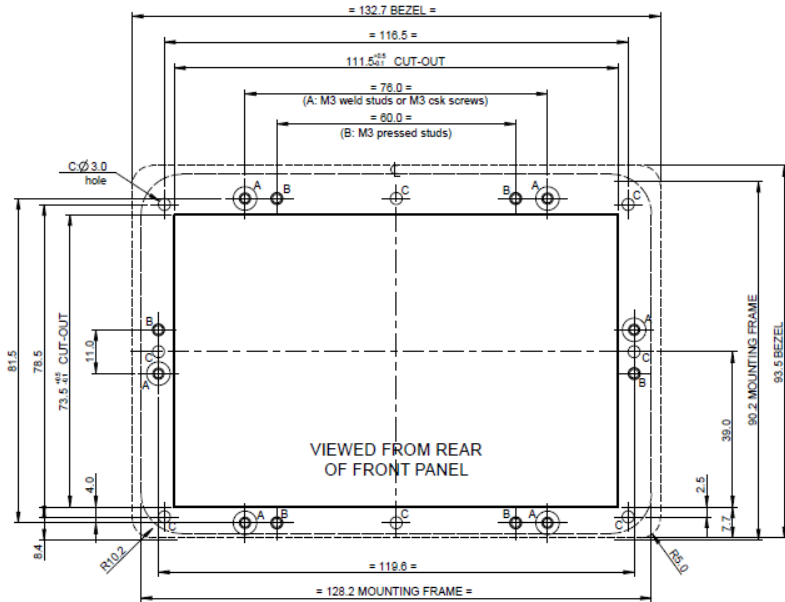

**Figure 6-4 - VM800BU 4.3" panel mount dimensions**





## 7 Specifications

### 7.1 Optical Specification

Item	Symbol	Condition	Min	Typ.	Max.	Unit
View Angles	$\Theta T$	$CR \geq 10$	30	40		Degree
	$\Theta B$		50	60		
	$\Theta L$		50	60		
	$\Theta R$		50	60		
Contrast Ratio	CR	$\theta = 0^\circ$		350		
Response Time	$T_{on}$	$25^\circ C$		25	40	ms
	$T_{off}$					
Chromaticity	White	x	0.260	0.310	0.360	
		y	0.283	0.333	0.383	
	RED	x	0.574	0.624	0.674	
		y	0.318	0.368	0.418	
	GREEN	x	0.300	0.350	0.400	
		y	0.500	0.550	0.600	
	BLUE	x	0.093	0.143	0.193	
		y	0.069	0.119	0.169	
Uniformity	U		75	80		%
NTSC				50		%
Luminance	L			500		cd/m <sup>2</sup>

**Table 7-1 - 3.5" TFT Optical specification**

Item	Symbol	Condition	Min.	Typ.	Max.	Unit
Brightness	Bp	$\theta = 0^\circ$	-	350	-	Cd/m <sup>2</sup>
Uniformity	$\Delta Bp$	$\Phi = 0^\circ$	70	80	-	%
Viewing Angle	3:00	$Cr \geq 10$	-	45	-	Deg
	6:00		-	20	-	
	9:00		-	45	-	
	12:00		-	40	-	
Contrast Ratio	Cr	$\theta = 0^\circ$	350	500		-
Response Time	$T_r$	$\Phi = 0^\circ$	-	10	-	ms
	$T_f$		-	10	-	ms
Color of CIE Coordinate	W	x		0.28		-
		y		0.33		-
	R	x		0.51		-
		y		0.34		-
	G	x		0.31		-
		y		0.56		-
	B	x		0.15		-
		y		0.14		-
NTSC Ratio	S	$\theta = 0^\circ$ $\Phi = 0^\circ$	50	60	-	%

**Table 7-2 - 4.3" TFT Optical Specification**

Item	Symbol	Condition	Min.	Typ.	Max.	Unit
Brightness	Bp	$\theta=0^\circ$	200	250	-	Cd/m <sup>2</sup>
Uniformity	$\Delta$ Bp	$\Phi=0^\circ$	70	80	-	%
Viewing Angle	3:00	Cr $\geq$ 10	-	45	-	Deg
	6:00		-	25	-	
	9:00		-	45	-	
	12:00		-	45	-	
Contrast Ratio	Cr	$\theta=0^\circ$ $\Phi=0^\circ$	350	500		-
Response Time	T <sub>r</sub>		-	10	-	ms
	T <sub>f</sub>		-	10	-	ms
Color of CIE Coordinate	W	x	$\theta=0^\circ$ $\Phi=0^\circ$	0.28		-
		y		0.33		-
	R	x		0.51		-
		y		0.34		-
	G	x		0.31		-
		y		0.56		-
	B	x		0.15		-
		y		0.14		-
NTSC Ratio	S	50	60	-	%	

**Table 7-3 - 5" TFT Optical Specification**

## 8 Contact Information

### Head Quarters – Singapore

Bridgetek Pte Ltd  
178 Paya Lebar Road, #07-03  
Singapore 409030  
Tel: +65 6547 4827  
Fax: +65 6841 6071

E-mail (Sales) [sales.apac@brtchip.com](mailto:sales.apac@brtchip.com)  
E-mail (Support) [support.apac@brtchip.com](mailto:support.apac@brtchip.com)

### Branch Office – Taipei, Taiwan

Bridgetek Pte Ltd, Taiwan Branch  
2 Floor, No. 516, Sec. 1, Nei Hu Road, Nei Hu District  
Taipei 114  
Taiwan, R.O.C.  
Tel: +886 (2) 8797 5691  
Fax: +886 (2) 8751 9737

E-mail (Sales) [sales.apac@brtchip.com](mailto:sales.apac@brtchip.com)  
E-mail (Support) [support.apac@brtchip.com](mailto:support.apac@brtchip.com)

### Branch Office - Glasgow, United Kingdom

Bridgetek Pte. Ltd.  
Unit 1, 2 Seaward Place, Centurion Business Park  
Glasgow G41 1HH  
United Kingdom  
Tel: +44 (0) 141 429 2777  
Fax: +44 (0) 141 429 2758

E-mail (Sales) [sales.emea@brtchip.com](mailto:sales.emea@brtchip.com)  
E-mail (Support) [support.emea@brtchip.com](mailto:support.emea@brtchip.com)

### Branch Office – Vietnam

Bridgetek VietNam Company Limited  
Lutaco Tower Building, 5th Floor, 173A Nguyen Van  
Tro, Ward 11, Phu Nhuan District,  
Ho Chi Minh City, Vietnam  
Tel : 08 38453222  
Fax : 08 38455222

E-mail (Sales) [sales.apac@brtchip.com](mailto:sales.apac@brtchip.com)  
E-mail (Support) [support.apac@brtchip.com](mailto:support.apac@brtchip.com)

### Web Site

<http://brtchip.com/>

### Distributor and Sales Representatives

Please visit the Sales Network page of the [Bridgetek Web site](#) for the contact details of our distributor(s) and sales representative(s) in your country.

System and equipment manufacturers and designers are responsible to ensure that their systems, and any Future Technology Devices International Ltd (FTDI) devices incorporated in their systems, meet all applicable safety, regulatory and system-level performance requirements. All application-related information in this document (including application descriptions, suggested FTDI devices and other materials) is provided for reference only. While FTDI has taken care to assure it is accurate, this information is subject to customer confirmation, and FTDI disclaims all liability for system designs and for any applications assistance provided by FTDI. Use of FTDI devices in life support and/or safety applications is entirely at the user's risk, and the user agrees to defend, indemnify and hold harmless FTDI from any and all damages, claims, suits or expense resulting from such use. This document is subject to change without notice. No freedom to use patents or other intellectual property rights is implied by the publication of this document. Neither the whole nor any part of the information contained in, or the product described in this document, may be adapted or reproduced in any material or electronic form without the prior written consent of the copyright holder. Future Technology Devices International Ltd, Unit 1, 2 Seaward Place, Centurion Business Park, Glasgow G41 1HH, United Kingdom. Scotland Registered Company Number: SC136640

## Appendix A - References

### Document References

FT800 datasheet: [DS\\_FT800\\_Embedded\\_Video\\_Engine](#)

FT800 software programming guide: [FT800\\_Programmer\\_Guide](#)

FT800 sample application notes:

[AN\\_245\\_VM800CB\\_SampleAPP\\_PC\\_Introduction](#)

FT800 Software examples:

[http://www.ftdichip.com/Support/SoftwareExamples/FT800\\_Projects.htm](http://www.ftdichip.com/Support/SoftwareExamples/FT800_Projects.htm)

D2xx Programmers Guide:

[http://www.ftdichip.com/Support/Documents/ProgramGuides/D2XX\\_Programmer's\\_Guide\(FT\\_000071\).pdf](http://www.ftdichip.com/Support/Documents/ProgramGuides/D2XX_Programmer's_Guide(FT_000071).pdf)

AN\_108: Command Processor for MPSSE and MCU Host Bus Emulation Modes

[http://www.ftdichip.com/Support/Documents/AppNotes/AN\\_108\\_Command\\_Processor\\_for\\_MPSSE\\_and\\_MCU\\_Host\\_Bus\\_Emulation\\_Modes.pdf](http://www.ftdichip.com/Support/Documents/AppNotes/AN_108_Command_Processor_for_MPSSE_and_MCU_Host_Bus_Emulation_Modes.pdf)

User Guide for libMPSSE – SPI

[http://www.ftdichip.com/Support/Documents/AppNotes/AN\\_178\\_User\\_Guide\\_For\\_LibMPSSE-SPI.pdf](http://www.ftdichip.com/Support/Documents/AppNotes/AN_178_User_Guide_For_LibMPSSE-SPI.pdf)

## Appendix B - List of Figures and Tables

### List of Figures

Figure 3-1 - VM800BU module profile 3.5" display version .....	4
Figure 3-2 - VM800BU module profile 4.3" display version .....	4
Figure 3-3 - VM800BU module profile 5" display version .....	4
Figure 3-4 - VM800BU module PCB view, 3.5" display version .....	5
Figure 3-5 - VM800BU module PCB view, 4.3" and 5" display version .....	6
Figure 4-1 - VM800BU35A LCD Interface (3.5" Version).....	8
Figure 4-2 - VM800BU43A/VM800BU50A LCD Interface (4.3"/5.0" Version) .....	9
Figure 4-3 - VM800BU SPI Interface and Power Input .....	10
Figure 4-4 - VM800BU Audio Circuits .....	10
Figure 5-1 - VM800BU Connects to PC through USB.....	12
Figure 6-1 - VM800BU Panel Mount (Front view).....	13
Figure 6-2 - VM800BU Panel Mount (Rear view).....	13
Figure 6-3 - VM800BU 3.5" panel mount dimensions.....	14
Figure 6-4 - VM800BU 4.3" panel mount dimensions.....	15
Figure 6-5 - VM800BU 5.0" panel mount dimensions.....	16

### List of Tables

Table 2-1 - Ordering information.....	2
Table 3-1 - CN1 Pinout.....	6
Table 3-2 - CN2 Pinout.....	6
Table 3-3 - J2 Pin Options .....	7
Table 3-4 - JP1 Pin options .....	7
Table 3-5 - SW1 jumper options .....	7
Table 5-1 - Board power configuration.....	11
Table 7-1 - 3.5" TFT Optical specification .....	17
Table 7-2 - 4.3" TFT Optical Specification .....	17
Table 7-3 - 5" TFT Optical Specification .....	18

## Appendix C – Revision History

Document Title: VM800BU Datasheet  
Document Reference No.: BRT\_000019  
Clearance No.: BRT#007  
Product Page: <http://brtchip.com/product>  
Document Feedback: [Send Feedback](#)

Revision	Changes	Date
Version 1.0	Initial Release	2014-07-14
Version 1.1	Dual branding to reflect the migration of the product to the Bridgetek name – logo changed, copyright changed, contact information changed	2016-09-13





Компания «ЭлектроПласт» предлагает заключение долгосрочных отношений при поставках импортных электронных компонентов на взаимовыгодных условиях!

Наши преимущества:

- Оперативные поставки широкого спектра электронных компонентов отечественного и импортного производства напрямую от производителей и с крупнейших мировых складов;
- Поставка более 17-ти миллионов наименований электронных компонентов;
- Поставка сложных, дефицитных, либо снятых с производства позиций;
- Оперативные сроки поставки под заказ (от 5 рабочих дней);
- Экспресс доставка в любую точку России;
- Техническая поддержка проекта, помощь в подборе аналогов, поставка прототипов;
- Система менеджмента качества сертифицирована по Международному стандарту ISO 9001;
- Лицензия ФСБ на осуществление работ с использованием сведений, составляющих государственную тайну;
- Поставка специализированных компонентов (Xilinx, Altera, Analog Devices, Intersil, Interpoint, Microsemi, Aeroflex, Peregrine, Syfer, Eurofarad, Texas Instrument, Miteq, Cobham, E2V, MA-COM, Hittite, Mini-Circuits, General Dynamics и др.);

Помимо этого, одним из направлений компании «ЭлектроПласт» является направление «Источники питания». Мы предлагаем Вам помощь Конструкторского отдела:

- Подбор оптимального решения, техническое обоснование при выборе компонента;
- Подбор аналогов;
- Консультации по применению компонента;
- Поставка образцов и прототипов;
- Техническая поддержка проекта;
- Защита от снятия компонента с производства.



#### Как с нами связаться

**Телефон:** 8 (812) 309 58 32 (многоканальный)

**Факс:** 8 (812) 320-02-42

**Электронная почта:** [org@eplast1.ru](mailto:org@eplast1.ru)

**Адрес:** 198099, г. Санкт-Петербург, ул. Калинина, дом 2, корпус 4, литера А.