



The Future of Analog IC Technology®

MP2014

40V, 500mA, Low Quiescent Current Linear Regulator

DESCRIPTION

The MP2014 is a low power linear regulator that supplies power to systems with high voltage batteries. It includes a wide 3V to 40V input range, low dropout voltage and low quiescent supply current. The low quiescent current and low dropout voltage allow operations at extremely low power levels. Therefore, the MP2014 is ideal for the low power microcontrollers and the battery-powered equipments.

The MP2014 provides wide variety of fixed output voltage options (if request): 1.8V, 1.9V, 2.3V, 2.5V, 3.0V, 3.3V, 3.45V, 5.0V.

The regulator output current is internally limited and the device is protected against short-circuit, over-load and over-temperature conditions.

The MP2014 also includes thermal shutdown and current limiting fault protection, and is available in TO252-5 package.

FEATURES

- 3V to 40V Input Range
- 10 μ A Quiescent Supply Current
- Stable with Low-Value Output Ceramic Capacitor (>0.47 μ F)
- 500mA Specified Current
- Fixed Output Voltage
- Output \pm 2% Accuracy
- Specified Current Limit
- Power Good
- Programmable Power Good Delay
- Thermal Shutdown and Short-Circuit Protection
- -40°C to +150°C Specified Junction Temperature Range
- Available in TO252-5 Package

APPLICATIONS

- Industrial/Automotive Applications
- Portable/Battery-Powered Equipment
- Ultra Low Power Microcontrollers
- Cellular Handsets
- Medical Imaging

All MPS parts are lead-free, halogen-free, and adhere to the RoHS directive. For MPS green status, please visit the MPS website under Quality Assurance.

"MPS" and "The Future of Analog IC Technology" are registered trademarks of Monolithic Power Systems, Inc.

TYPICAL APPLICATION

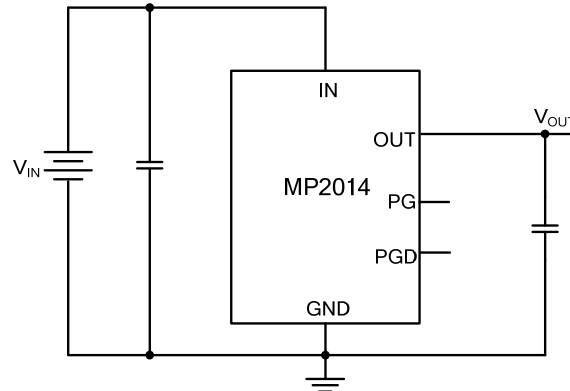

ORDERING INFORMATION

Part Number*	Package	Top Marking
MP2014GZD	TO252-5	See Below
MP2014GZD-33	TO252-5	See Below

* For Tape & Reel, add suffix -Z (e.g. MP2014GZD-Z)

TOP MARKING (MP2014GZD)

MPSYYWW
MP2014
LLLLLLLLL

MPS: MPS Prefix
 YY: Year Code
 WW: Week Code
 MP2014: Product Code of MP2014GZD
 LLLLLLLLL: Lot Number

TOP MARKING (MP2014GZD-33)

MPS YYWW
MP2014-33
LLLLLLLLL

MPS: MPS Prefix
 YY: Year Code
 WW: Week Code
 MP2014-33: Product Code of MP2014GZD-33
 LLLLLLLLL: Lot Number

PACKAGE REFERENCE

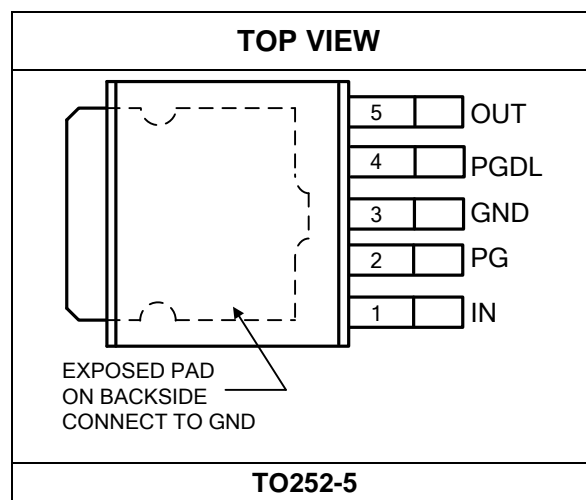

ABSOLUTE MAXIMUM RATINGS ⁽¹⁾

IN	-0.3V to +42V
OUT	-0.3V to +17V
PG	-0.3V to +15V
PGDL	-0.3V to +6V
Lead Temperature	260°C
Storage Temperature	-65°C to +150°C
Continuous Power Dissipation (T _A = +25°C) ⁽²⁾	
TO252-5	2.27W

ESD SUSCEPTIBILITY ⁽³⁾

HBM (Human Body Mode)	4kV
MM (Machine Mode)	200V

Recommended Operating Conditions ⁽⁴⁾

Supply Voltage V _{IN}	3V to 40V
Operating Temperature	T _A = -40°C to +125°C
	T _A ≤ T _J ≤ +150°C

Thermal Resistance ⁽⁵⁾	θ_{JA}	θ_{JC}
TO252-5	55	3

Notes:

- 1) Exceeding these ratings may damage the device.
- 2) The maximum allowable power dissipation is a function of the maximum junction temperature T_J (MAX), the junction-to-ambient thermal resistance θ_{JA}, and the ambient temperature T_A. The maximum allowable continuous power dissipation at any ambient temperature is calculated by P_D (MAX) = (T_J (MAX) - T_A) / θ_{JA}. Exceeding the maximum allowable power dissipation will cause excessive die temperature, and the regulator will go into thermal shutdown. Internal thermal shutdown circuitry protects the device from permanent damage.
- 3) Devices are ESD sensitive. Handling precaution recommended.
- 4) The device is not guaranteed to function outside of its operating conditions.
- 5) Measured on JESD51-7, 4-layer PCB.

ELECTRICAL CHARACTERISTICS
 $V_{IN}=13.5V$, $T_J = +25^{\circ}C$, unless otherwise noted.

Parameter	Symbol	Condition	Min	Typ	Max	Units
GND Pin Current	I_{GND}	$0 < I_{OUT} < 1mA$		12	17	μA
		$1mA < I_{OUT} < 30mA$		16	22	
		$30mA < I_{OUT} < 500mA$		105	150	
Load Current Limit	I_{LIMIT}	$V_{OUT} = 0V$	550	900	1450	mA
Output Voltage accuracy		MP2014GZD, $V_{IN} = 6V$ to 40V, $I_{LOAD} = 5mA$	4.9	5	5.1	V
		MP2014GZD-33, $V_{IN} = 4.3V$ to 40V, $I_{LOAD} = 5mA$	3.234	3.3	3.366	
Dropout Voltage ⁽⁶⁾	$V_{DROPOUT}$	MP2014GZD, $I_{LOAD} = 300mA$, $V_{DROPOUT} = V_{IN} - V_O$		400	650	mV
		MP2014GZD-33, $I_{LOAD} = 300mA$, $V_{DROPOUT} = V_{IN} - V_O$		500	700	
		MP2014GZD, $I_{LOAD} = 500mA$, $V_{DROPOUT} = V_{IN} - V_O$		750	1000	
		MP2014GZD-33, $I_{LOAD} = 500mA$, $V_{DROPOUT} = V_{IN} - V_O$		1000	1300	
Line Regulation		$V_{IN} = 8V$ to 40V, $I_{LOAD} = 5mA$	-10	1	10	mV
Load Regulation		$I_{LOAD} = 5mA$ to 500mA		1	15	mV
Output Voltage PSRR ⁽⁷⁾		100Hz, $C_{OUT} = 10\mu F$, $I_{LOAD} = 10mA$		57		dB
		1kHz, $C_{OUT} = 10\mu F$, $I_{LOAD} = 10mA$		45		dB
		100kHz, $C_{OUT} = 10\mu F$, $I_{LOAD} = 10mA$		51		dB
Startup Response Time		MP2014GZD, $I_{LOAD} = 10mA$, $C_{OUT} = 22\mu F$		1	2	ms
		MP2014GZD-33, $I_{LOAD} = 10mA$, $C_{OUT} = 22\mu F$		0.6	1.5	
PG Rising Threshold			90%	93%	96%	V_{OUT}
PG Rising Threshold Hysteresis				5%		V_{OUT}
PG Low Voltage		Sink 1mA current		0.1	0.4	V
PG Leakage Current		$V_{PG} = 5V$			1	μA
PGDL Charging Current	I_{PGDL}	$V_{PGDL} = 1V$	3	5.5	9	μA
PGDL Rising Threshold			1.5	1.65	2	V
PGDL Falling Threshold			0.2	0.4	0.7	V
PG Delay Time	t_{PGDL}	$C_{PGDL} = 47nF$, 10% to 90% PGDL Rising Threshold	6	11	14	ms
PG Reaction Time		$C_{PGDL} = 47nF$		0.5	2	μs
Thermal Shutdown ⁽⁷⁾	T_{SD}			165		$^{\circ}C$
Thermal Shutdown Hysteresis ⁽⁷⁾	ΔT_{SD}			30		$^{\circ}C$

Notes:

- 6) Dropout voltage: Measured when the output voltage V_{OUT} has dropped 100mV from the nominal value obtained at $V_{IN} = 13.5V$.
7) Derived from bench characterization. Not tested in production.

PIN FUNCTIONS

Pin #	Name	Description
1	IN	Input voltage. Connect a 3V to 40V supply to this pin.
2	PG	Power good.
3	GND	Ground (internally connected to the exposed pad, GND pin and the exposed pad must be connected to the same ground plane)
4	PGDL	Programmable power good delay time.
5	OUT	Regulated output voltage, only low-value ceramic capacitor ($\geq 0.47\mu\text{F}$) on output is required for stability.

TYPICAL PERFORMANCE CHARACTERISTICS

$C_{IN} = 1\mu F$, $C_{OUT} = 22\mu F$, $V_{OUT} = 5V$, $T_A = 25^\circ C$, unless otherwise noted.

Dropout vs. Load Current

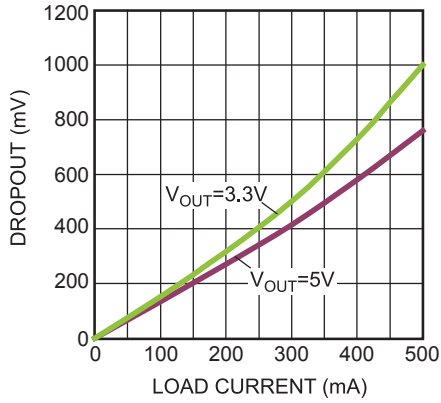

V_{OUT} vs. I_{OUT}

MP2014GZD, $V_{IN}=6V$

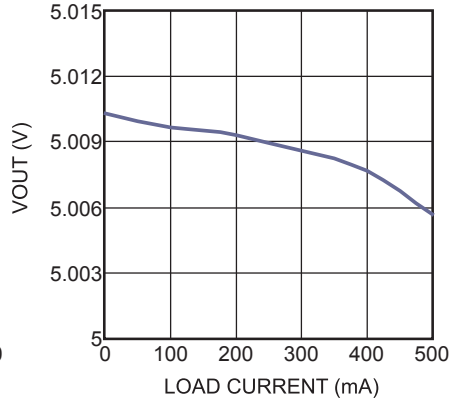

V_{OUT} vs. I_{OUT}

MP2014GZD-33, $V_{IN}=4.5V$

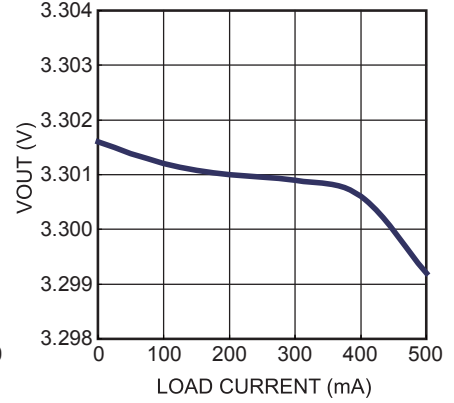

V_{OUT} vs. V_{IN}

MP2014GZD

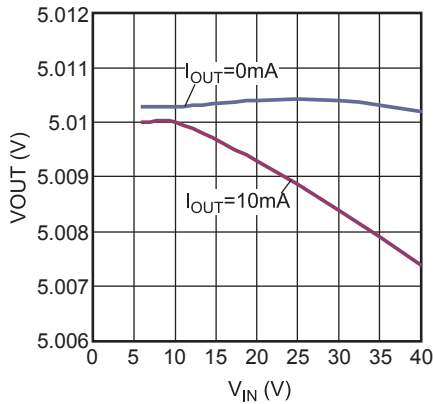

V_{OUT} vs. V_{IN}

MP2014GZD-33

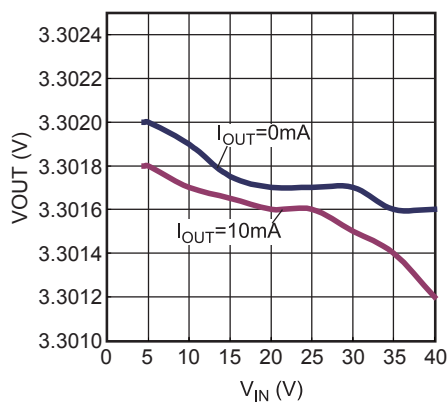

PSRR vs. Frequency

$C_{IN}=100pF$, $C_{OUT}=10\mu F$, $I_{OUT}=10mA$

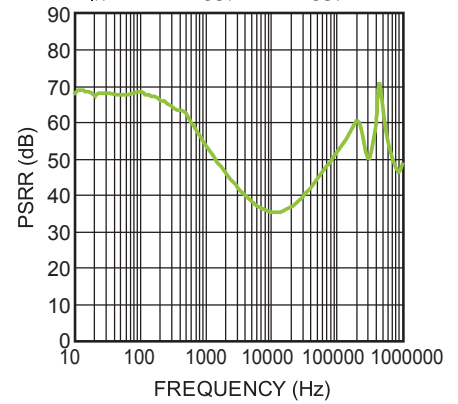

TYPICAL PERFORMANCE CHARACTERISTICS (continued)
 $C_{IN} = 1\mu F$, $C_{OUT} = 22\mu F$, $V_{OUT} = 5V$, $T_A = 25^\circ C$, unless otherwise noted.

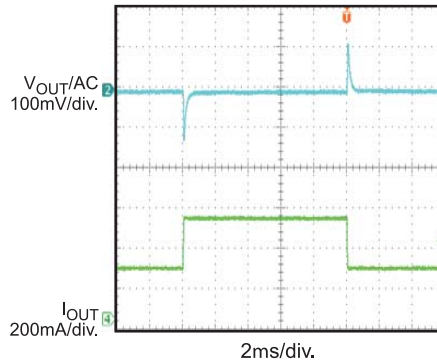
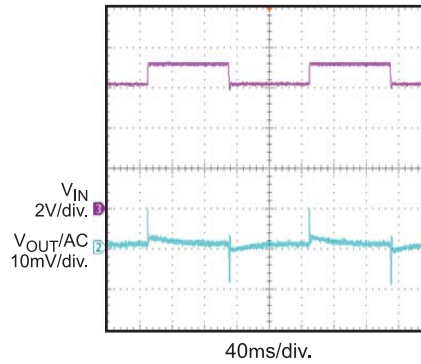
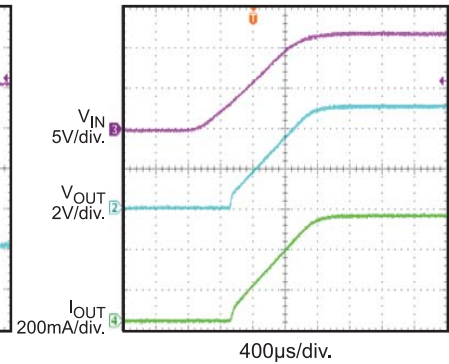
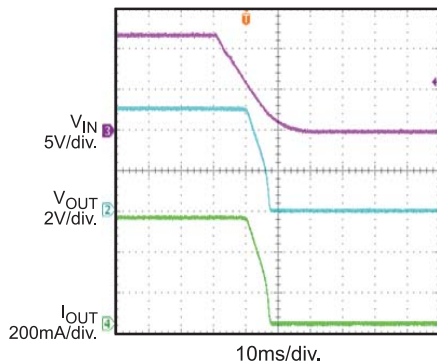
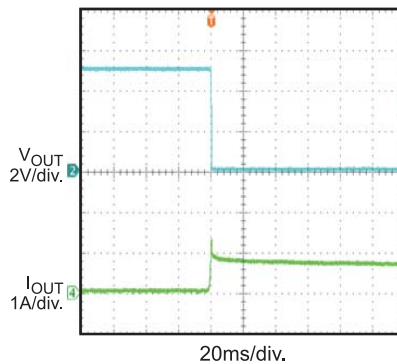
Load Transient
 $V_{IN}=12V$, $I_{OUT}=250mA-500mA$

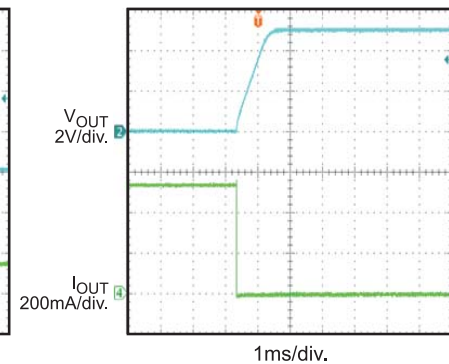
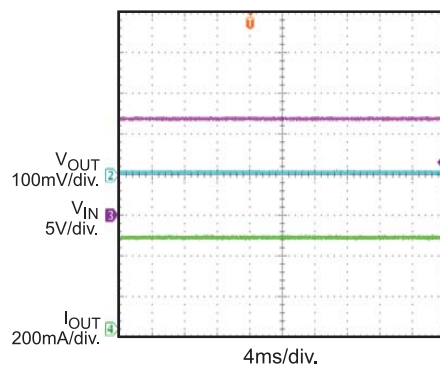
Line Transient
 $V_{IN}=6V-7V$, $I_{OUT}=500mA$

Start-Up through V_{IN}
 $V_{IN}=12V$, $I_{OUT}=500mA$

Shutdown through V_{IN}
 $V_{IN}=12V$, $I_{OUT}=500mA$

Short-Circuit Entry
 $I_{OUT}=0mA$ to Short Circuit

Short-Circuit Recovery

Short Circuit to $I_{OUT}=0mA$

Short-Circuit Steady State
 $V_{IN}=12V$

OPERATION

The MP2014 is a linear regulator that supplies power to systems with high voltage batteries. It includes a wide 3V to 40V input range, low dropout voltage and low quiescent supply current.

The MP2014 provides wide variety of fixed output voltage options: 1.8V, 1.9V, 2.3V, 2.5V, 3.0V, 3.3V, 3.45V, 5.0V.

Short-Circuit Protection

The regulator output current is internally limited and the device is protected against short-circuit, over-load. The peak output current is limited to around 900mA, which exceeds the 500mA recommended continuous output current.

Thermal Shutdown

When the junction temperature exceeds the upper threshold (165°C), the thermal sensor sends a signal to the control logic to shutdown the IC. The IC will restart when the temperature has sufficiently cooled (135°C).

The maximum power output current is a function of the package's maximum power dissipation for a given temperature.

The maximum power dissipation is dependent on the thermal resistance of the case and the

circuit board, the temperature difference between the die junction and the ambient air, and the rate of air flow. The GND pin and Exposed Pad must be connected to the ground plane for proper dissipation.

Power Good Output

MP2014 has one power good (PG) pin. The PG pin is the open drain of an internal MOSFET. It should be connected to V_{OUT} or external voltage source (<15V) through a resistor (i.e. 100kohm). After the V_{OUT} reaches 93% of nominal value, the MOSFET turns off and PG pin is pulled to high by V_{OUT} or external voltage source. When the V_{OUT} drops to 88% of nominal value, the PG voltage is pulled to GND.

There is a delay time when PG asserts high. The delay time can be programmed by adding a capacitor on PGDL. To select a capacitor for PGDL, use below equation:

$$C_{PGDL} \text{ (nF)} = \frac{t_{PGDL} \text{ (ms)} \times I_{PGDL} \text{ (\mu A)}}{V_{th_PGDL} \text{ (V)}}$$

Where t_{PGDL} is the desired delay time for PG asserts high, I_{PGDL} is the PGDL charging current and V_{th_PGDL} is 1.65V.

Figure 2 shows the power good timing.

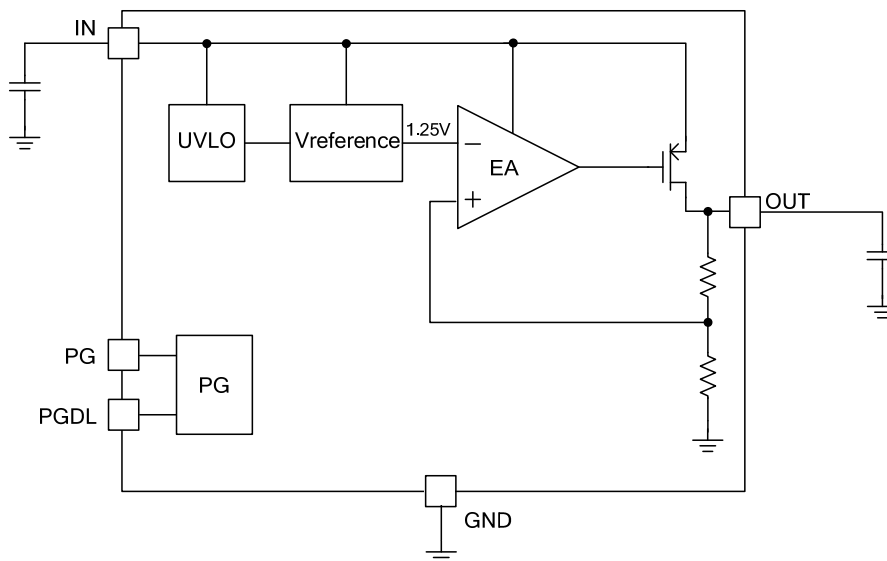

Figure 1: Functional Block Diagram

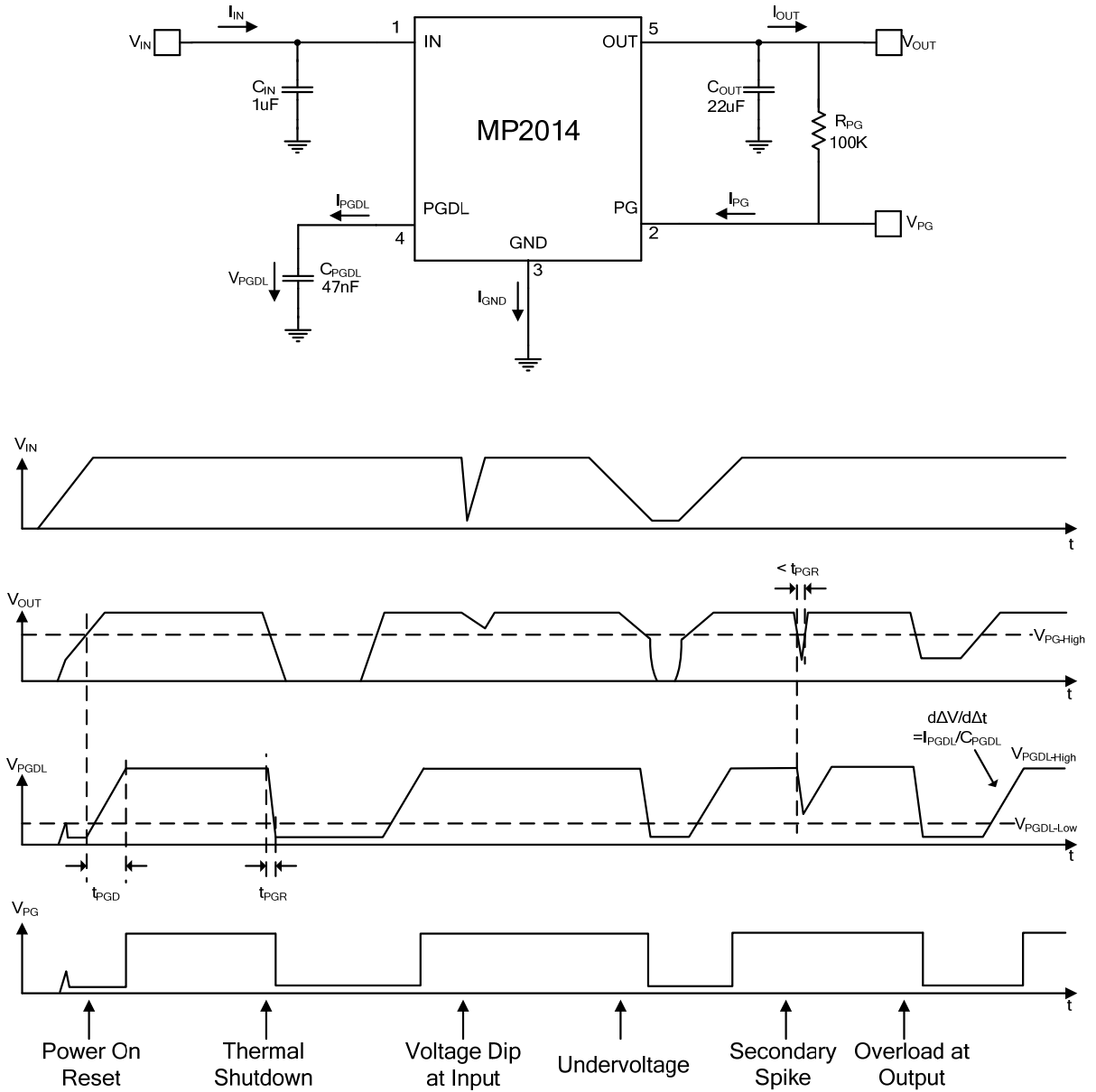

Figure 2: Power Good Timing

APPLICATION INFORMATION

Component Selection

Input Capacitor

For proper operation, place a ceramic capacitor (C1) between $1\mu\text{F}$ and $10\mu\text{F}$ of dielectric type X5R or X7R between the input pin and ground. Larger values in this range will help improve line transient response.

Output Capacitor

For stable operation, use a ceramic capacitor (C2) of type X5R or X7R between $1\mu\text{F}$ and $22\mu\text{F}$. Larger values in this range will help improve load transient response and reduce noise. Output capacitors of other dielectric types may be used, but are not recommended as their capacitance can deviate greatly from their rated value over temperature.

PCB Layout Guide

PCB layout is very important to achieve good regulation, ripple rejection, transient response and thermal performance. It is highly recommended to duplicate EVB layout for optimum performance.

If change is necessary, please follow these guidelines and take figure 3 for reference.

- 1) Input and output bypass ceramic capacitors are suggested to be put close to the IN Pin and OUT Pin respectively.
- 2) Connect IN, OUT and especially GND respectively to a large copper area to cool the chip to improve thermal performance and long-term reliability.

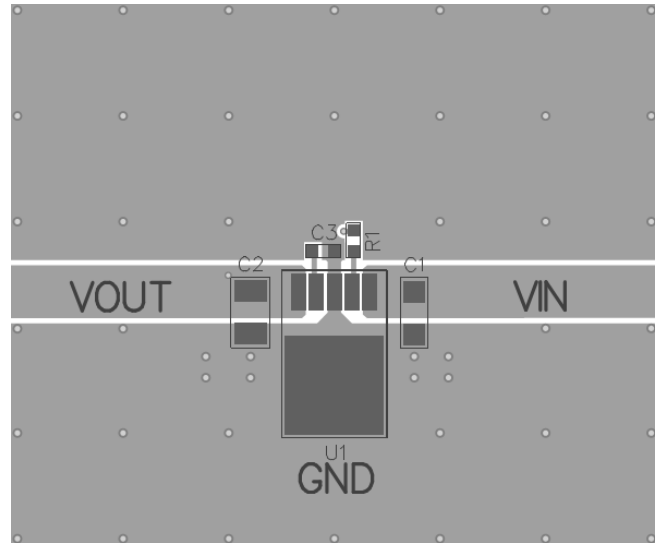
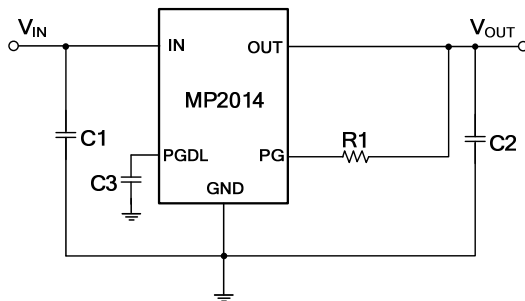

Top Layer

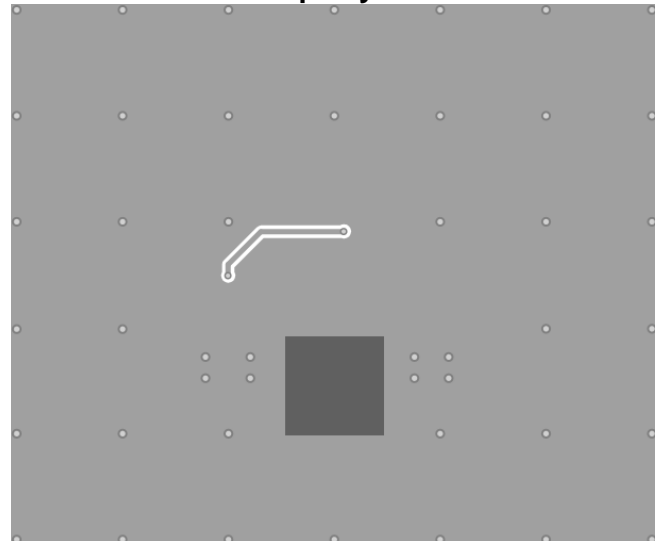

Bottom Layer

Figure 3: PCB Layout

DESIGN EXAMPLE

Below is a design example following the application guidelines.

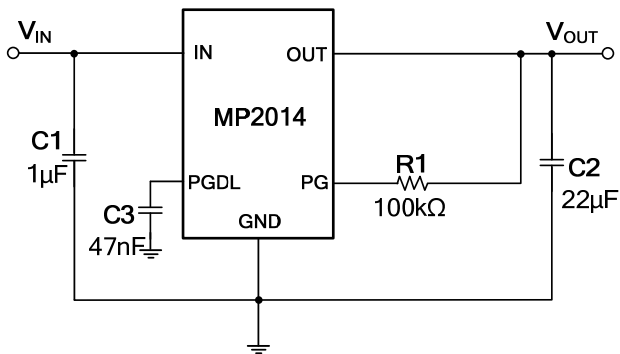

Figure 4: Design Example

TYPICAL APPLICATION CIRCUITS

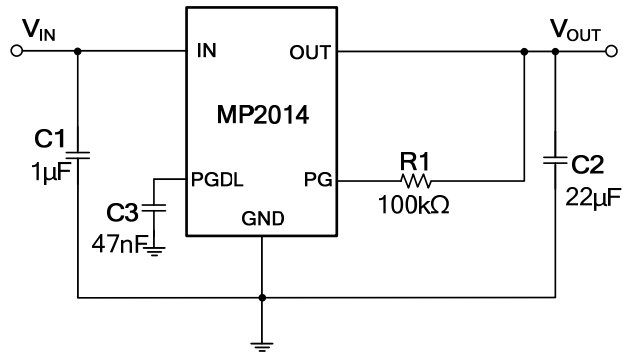
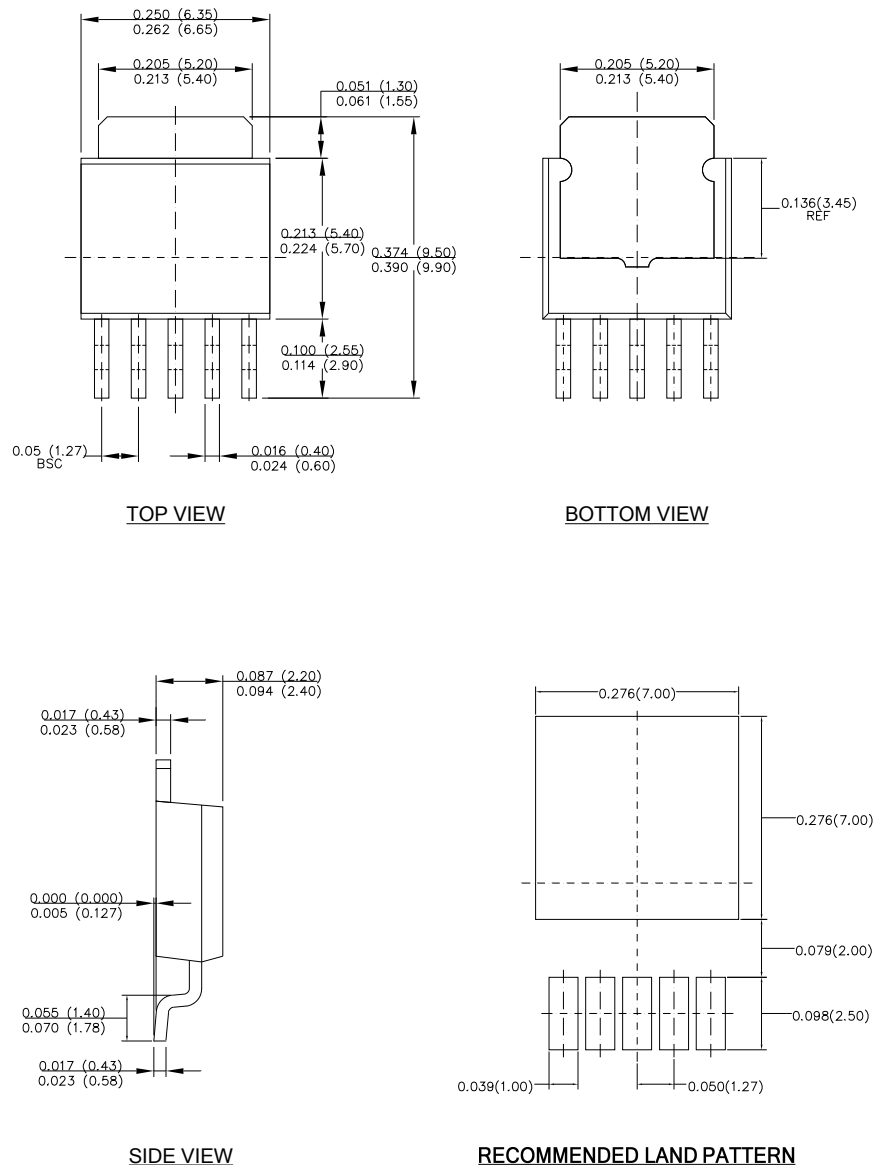

Figure 5: Typical Application Circuit

PACKAGE INFORMATION
TO252-5

NOTE:

- 1) CONTROL DIMENSION IS IN INCHES. DIMENSION IN BRACKET IS IN MILLIMETERS.
- 2) PACKAGE LENGTH DOES NOT INCLUDE MOLD FLASH, PROTRUSIONS OR GATE BURRS.
- 3) PACKAGE WIDTH DOES NOT INCLUDE INTERLEAD FLASH OR PROTRUSIONS.
- 4) DRAWING CONFORMS TO JEDEC TO-252.
- 5) DRAWING IS NOT TO SCALE.

NOTICE: The information in this document is subject to change without notice. Please contact MPS for current specifications. Users should warrant and guarantee that third party Intellectual Property rights are not infringed upon when integrating MPS products into any application. MPS will not assume any legal responsibility for any said applications.



Компания «ЭлектроПласт» предлагает заключение долгосрочных отношений при поставках импортных электронных компонентов на взаимовыгодных условиях!

Наши преимущества:

- Оперативные поставки широкого спектра электронных компонентов отечественного и импортного производства напрямую от производителей и с крупнейших мировых складов;
- Поставка более 17-ти миллионов наименований электронных компонентов;
- Поставка сложных, дефицитных, либо снятых с производства позиций;
- Оперативные сроки поставки под заказ (от 5 рабочих дней);
- Экспресс доставка в любую точку России;
- Техническая поддержка проекта, помощь в подборе аналогов, поставка прототипов;
- Система менеджмента качества сертифицирована по Международному стандарту ISO 9001;
- Лицензия ФСБ на осуществление работ с использованием сведений, составляющих государственную тайну;
- Поставка специализированных компонентов (Xilinx, Altera, Analog Devices, Intersil, Interpoint, Microsemi, Aeroflex, Peregrine, Syfer, Eurofarad, Texas Instrument, Miteq, Cobham, E2V, MA-COM, Hittite, Mini-Circuits, General Dynamics и др.);

Помимо этого, одним из направлений компании «ЭлектроПласт» является направление «Источники питания». Мы предлагаем Вам помощь Конструкторского отдела:

- Подбор оптимального решения, техническое обоснование при выборе компонента;
- Подбор аналогов;
- Консультации по применению компонента;
- Поставка образцов и прототипов;
- Техническая поддержка проекта;
- Защита от снятия компонента с производства.



Как с нами связаться

Телефон: 8 (812) 309 58 32 (многоканальный)

Факс: 8 (812) 320-02-42

Электронная почта: org@eplast1.ru

Адрес: 198099, г. Санкт-Петербург, ул. Калинина, дом 2, корпус 4, литера А.