

## FEATURES

- Single Supply Operation
  - Input Voltage Range Extends to Ground
  - Output Swings to Ground while Sinking Current
- *Guaranteed* Offset Voltage: 50 $\mu$ V Max
- *Guaranteed* Low Drift: 1.3 $\mu$ V/ $^{\circ}$ C Max
- *Guaranteed* Offset Current: 0.5nA Max
- *Guaranteed* High Gain
  - 5mA Load Current: 1.5 Million Min
  - 17mA Load Current: 0.8 Million Min
- *Guaranteed* Low Supply Current: 520 $\mu$ A Max
- Supply Current can be Reduced by a Factor of 4
- Low Voltage Noise, 0.1Hz to 10Hz: 0.55 $\mu$ V<sub>P-P</sub>
  - Low Current Noise—
  - Better than OP-07: 0.07pA/ $\sqrt{\text{Hz}}$  at 10Hz
- High Input Impedance: 250M $\Omega$  Min
- Minimum Supply Voltage: 2.7V Min

## APPLICATIONS

- Low Power Sample-and-Hold Circuits
- Battery-Powered Precision Instrumentation
  - Strain Gauge Signal Conditioners
  - Thermocouple Amplifiers
- 4mA to 20mA Current Loop Transmitters
- Active Filters

## DESCRIPTION

The LT<sup>®</sup>1006 is the first precision single supply operational amplifier. Its design has been optimized for single supply operation with a full set of specifications at 5V. Specifications at  $\pm 15$ V are also provided.

The LT1006 has a low offset voltage of 20 $\mu$ V, drift of 0.2 $\mu$ V/ $^{\circ}$ C, offset current of 120pA, gain of 2.5 million, common mode rejection of 114dB and power supply rejection of 126dB.

Although supply current is only 340 $\mu$ A, a novel output stage can source or sink in excess of 20mA while retaining high voltage gain. Common mode input range includes ground to accommodate low ground-referenced inputs from strain gauges or thermocouples, and output can swing to within a few millivolts of ground. If a higher slew rate (in excess of 1V/ $\mu$ s) or micropower operation (supply current down to 90 $\mu$ A) is required, the operating currents can be modified by connecting an external optional resistor to Pin 8.

For similar single supply precision dual and quad op amps, please see the LT1013/LT1014 data sheet. For micropower dual and quad op amps, please see the LT1078/LT1079 data sheet.

 LTC and LT are registered trademarks of Linear Technology Corporation.

## TYPICAL APPLICATION

LT1006 Single Supply, Micropower Sample and Hold

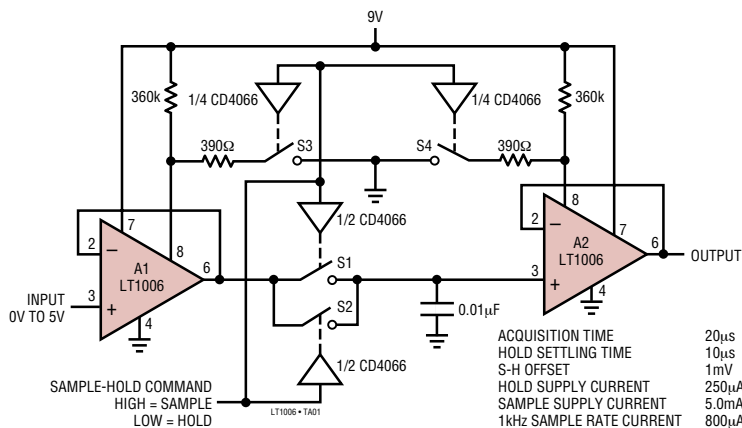

Distribution of Input Offset Voltage

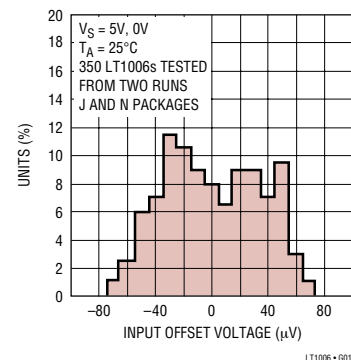

# LT1006

## ABSOLUTE MAXIMUM RATINGS (Note 1)

Supply Voltage .....  $\pm 22V$   
 Input Voltage ..... Equal to Positive Supply Voltage  
 Input Voltage ..... 5V Below Negative Supply Voltage  
 Differential Input Voltage ..... 30V  
 Output Short-Circuit Duration ..... Indefinite

Operating Temperature Range  
 LT1006AM/LT1006M (**OBSELETE**)....  $-55^{\circ}C$  to  $125^{\circ}C$   
 LT1006AC/LT1006C/LT1006S8 .....  $0^{\circ}C$  to  $70^{\circ}C$   
 Storage Temperature Range .....  $-65^{\circ}C$  to  $150^{\circ}C$   
 Lead Temperature (Soldering, 10 sec) .....  $300^{\circ}C$

## PACKAGE/ORDER INFORMATION

<p>TOP VIEW  <math>I_{SY}</math> SET (NOTE 3)  <math>V_{OS}</math> TRIM  <math>-IN</math>  <math>+IN</math>  <math>V^{-}</math>  <math>V_{OS}</math> TRIM (NOTE 4)  <math>OUT</math>  <math>V^{+}</math>                  (CASE)                  H PACKAGE                  8-LEAD TO-5 METAL CAN  <math>T_{JMAX} = 150^{\circ}C</math>, <math>\theta_{JA} = 150^{\circ}C/W</math>, <math>\theta_{JC} = 45^{\circ}C</math></p>	ORDER PART NUMBER	<p>TOP VIEW  <math>V_{OS}</math> TRIM  <math>-IN</math>  <math>+IN</math>  <math>V^{-}</math>  <math>V^{-}</math>  <math>OUT</math>  <math>V^{+}</math>  <math>I_{SY}</math> SET (NOTE 3)                  N8 PACKAGE                  8-LEAD PDIP  <math>T_{JMAX} = 100^{\circ}C</math>, <math>\theta_{JA} = 130^{\circ}C/W</math> (N8)  <math>T_{JMAX} = 150^{\circ}C</math>, <math>\theta_{JA} = 200^{\circ}C/W</math> (S8)</p>	ORDER PART NUMBER
	LT1006AMH LT1006MH LT1006ACH LT1006CH		LT1006CN8 LT1006S8
			S8 PART MARKING
			1006
		J8 PACKAGE 8-LEAD CERDIP $T_{JMAX} = 100^{\circ}C$ , $\theta_{JA} = 130^{\circ}C/W$	LT1006AMJ8 LT1006MJ8 LT1006ACJ8 LT1006CJ8
<b>OBSELETE PACKAGES</b>			
Consider the N8 or S8 Package for Alternate Source			

Consult LTC Marketing for parts specified with wider operating temperature ranges.

## ELECTRICAL CHARACTERISTICS $V_S = 5V$ , $V_{CM} = 0V$ , $V_{OUT} = 1.4V$ , $T_A = 25^{\circ}C$ , unless otherwise noted.

SYMBOL	PARAMETER	CONDITIONS	LT1006AM/AC			LT1006M/C			UNITS
			MIN	TYP	MAX	MIN	TYP	MAX	
$V_{OS}$	Input Offset Voltage	LT1006S8		20	50	30	80		$\mu V$
						80	400		$\mu V$
$\frac{\Delta V_{OS}}{\Delta Time}$	Long-Term Input Offset Voltage Stability	LT1006S8		0.4		0.5			$\mu V/Mo$
						0.7			$\mu V/Mo$
$I_{OS}$	Input Offset Current			0.12	0.5	0.15	0.9		nA
$I_B$	Input Bias Current			9	15	10	25		nA
$e_n$	Input Noise Voltage	0.1Hz to 10Hz		0.55		0.55			$\mu V_{p-p}$
	Input Noise Voltage Density	$f_0 = 10Hz$		23	32	23	32		$nV/\sqrt{Hz}$
		$f_0 = 1000Hz$		22	25	22	25		$nV/\sqrt{Hz}$
$i_n$	Input Noise Current Density	$f_0 = 10Hz$		0.07		0.08			$pA/\sqrt{Hz}$
	Input Resistance	(Note 2)							$M\Omega$
	Differential Mode		180	400		100	300		$G\Omega$
	Common Mode			5			4		

1006fa

**ELECTRICAL CHARACTERISTICS**  $V_S = 5V$ ,  $V_{CM} = 0V$ ,  $V_{OUT} = 1.4V$ ,  $T_A = 25^\circ C$ , unless otherwise noted.

SYMBOL	PARAMETER	CONDITIONS	LT1006AM/AC			LT1006M/C			UNITS	
			MIN	TYP	MAX	MIN	TYP	MAX		
	Input Voltage Range		3.5 0	3.8 -0.3		3.5 0	3.8 -0.3		V V	
CMRR	Common Mode Rejection Ratio	$V_{CM} = 0V$ to $3.5V$	100	114		97	112		dB	
PSRR	Power Supply Rejection Ratio	$V_S = \pm 2V$ to $\pm 18V$ , $V_O = 0V$	106	126		103	124		dB	
$A_{VOL}$	Large-Signal Voltage Gain	$V_O = 0.03V$ to $4V$ , $R_L = 10k$ $V_O = 0.03V$ to $3.5V$ , $R_L = 2k$	1.0 0.5	2.5 2.0		0.7 0.3	2.0 1.8		V/ $\mu V$ V/ $\mu V$	
	Maximum Output Voltage Swing	Output Low, No Load		15	25		15	25	mV	
		Output Low, $600\Omega$ to GND		5	10		5	10	mV	
		Output Low, $I_{SINK} = 1mA$			220	350		220	350	mV
		Output High, No Load	4.0	4.4		4.0	4.4		V	
		Output High, $600\Omega$ to GND	3.4	4.0		3.4	4.0		V	
SR	Slew Rate		0.25	0.4		0.25	0.4		V/ $\mu s$	
$I_S$	Supply Current	$R_{SET} = \infty$ $R_{SET} = 180k$ Pin 8 to Pin 7 (Note 3)		340 90	520		350 90	570	$\mu A$ $\mu A$	
	Minimum Supply Voltage		2.7			2.7			V	

The ● denotes the specifications which apply over the full operating temperature range.  $V_S = 5V$ ,  $0V$ ;  $V_{CM} = 0.1V$ ;  $V_O = 1.4V$ ;  $-55^\circ C \leq T_A \leq 125^\circ C$ , unless otherwise noted.

SYMBOL	PARAMETER	CONDITIONS	LT1006AM			LT1006M			UNITS	
			MIN	TYP	MAX	MIN	TYP	MAX		
$V_{OS}$	Input Offset Voltage		●	40	180		60	250	$\mu V$	
$\frac{\Delta V_{OS}}{\Delta Temp}$	Input Offset Voltage Drift		●	0.2	1.3		0.3	1.8	$\mu V/^\circ C$	
$I_{OS}$	Input Offset Current		●	0.4	2.0		0.5	4.0	nA	
$I_B$	Input Bias Current		●	13	25		16	40	nA	
$A_{VOL}$	Large-Signal Voltage Gain	$V_O = 0.05V$ to $3.5V$ , $R_L = 2k$	●	0.25	0.8		0.15	0.7	V/ $\mu V$	
CMRR	Common Mode Rejection Ratio	$V_{CM} = 0.1V$ to $3.2V$	●	90	103		87	102	dB	
PSRR	Power Supply Rejection Ratio	$V_S = \pm 2V$ to $\pm 18V$ , $V_O = 0V$	●	100	117		97	116	dB	
	Maximum Output Voltage Swing	Output Low, $600\Omega$ to GND	●		6	15		6	18	mV
		Output High, $600\Omega$ to GND	●	3.2	3.8		3.1	3.8		V
$I_S$	Supply Current		●	380	630		400	680	$\mu A$	

## ELECTRICAL CHARACTERISTICS

The ● denotes the specifications which apply over the full operating temperature range.  $V_S = 5V, 0V$ ;  $V_{CM} = 0V$ ;  $V_O = 1.4V$ ;  $0^\circ C \leq T_A \leq 70^\circ C$ , unless otherwise noted.

SYMBOL	PARAMETER	CONDITIONS	LT1006AC			LT1006C			UNITS
			MIN	TYP	MAX	MIN	TYP	MAX	
$V_{OS}$	Input Offset Voltage	J8/H Package	●	30	110	45	160	$\mu V$	
		N8 Package	●			50	190	$\mu V$	
		S8 Package	●			110	560	$\mu V$	
$\frac{\Delta V_{OS}}{\Delta Temp}$	Input Offset Voltage Drift	J8/H Package	●	0.2	1.3	0.3	1.8	$\mu V/^\circ C$	
		N8 Package	●			0.5	2.5	$\mu V/^\circ C$	
		S8 Package	●			0.7	3.5	$\mu V/^\circ C$	
$I_{OS}$	Input Offset Current		●	0.25	1.2	0.3	2.5	nA	
$I_B$	Input Bias Current		●	11	20	12	30	nA	
$A_{VOL}$	Large-Signal Voltage Gain	$V_O = 0.04V$ to $3.5V$ , $R_L = 2k$	●	0.35	1.3	0.25	1.2	$V/\mu V$	
CMRR	Common Mode Rejection Ratio	$V_{CM} = 0V$ to $3.4V$	●	96	109	92	108	dB	
PSRR	Power Supply Rejection Ratio	$V_S = \pm 2V$ to $\pm 18V$ , $V_O = 0V$	●	101	120	97	118	dB	
	Maximum Output Voltage Swing	Output Low, $600\Omega$ to GND	●	6	13	6	13	mV	
		Output High, $600\Omega$ to GND	●	3.3	3.9	3.2	3.9	V	
$I_S$	Supply Current		●	350	570	360	620	$\mu A$	

$V_S = \pm 15V$ ,  $T_A = 25^\circ C$ , unless otherwise noted.

SYMBOL	PARAMETER	CONDITIONS	LT1006AM/AC			LT1006M/C			UNITS
			MIN	TYP	MAX	MIN	TYP	MAX	
$V_{OS}$	Input Offset Voltage	LT1006S8		30	100	50	180	$\mu V$	
						100	525	$\mu V$	
$I_{OS}$	Input Offset Current			0.1	0.5	0.15	0.9	nA	
$I_B$	Input Bias Current			7.5	12.0	8	20	nA	
	Input Voltage Range			13.5	13.8	13.5	13.8	V	
				-15.0	-15.3	-15.0	-15.3	V	
CMRR	Common Mode Rejection Ratio	$V_{CM} = +13.5V, -15V$		100	117	97	116	dB	
PSRR	Power Supply Rejection Ratio	$V_S = \pm 2V$ to $\pm 18V$ , $V_O = 0V$		106	126	103	124	dB	
$A_{VOL}$	Large Signal Voltage Gain	$V_O = \pm 10V$ , $R_L = 2k$ $V_O = \pm 10V$ , $R_L = 600\Omega$		1.5	5.0	1.2	4.0	$V/\mu V$	
				0.8	1.5	0.5	1.0	$V/\mu V$	
$V_{OUT}$	Maximum Output Voltage Swing	$R_L = 2k$		$\pm 13$	$\pm 14$	$\pm 12.5$	$\pm 14$	V	
SR	Slew Rate	$R_{SET} = \infty$ $R_{SET} = 390\Omega$ Pin 8 to Pin 4		0.25	0.4	0.25	0.4	$V/\mu s$	
				1.0	1.2	1.0	1.2	$V/\mu s$	
$I_S$	Supply Current			360	540	360	600	$\mu A$	

**ELECTRICAL CHARACTERISTICS** The ● denotes the specifications which apply over the full operating temperature range.  $V_S = \pm 15V$ ,  $-55^{\circ}C \leq T_A \leq 125^{\circ}C$ , unless otherwise noted.

SYMBOL	PARAMETER	CONDITIONS	LT1006AM			LT1006M			UNITS
			MIN	TYP	MAX	MIN	TYP	MAX	
$V_{OS}$	Input Offset Voltage		●	80	320		110	460	$\mu V$
$\frac{\Delta V_{OS}}{\Delta Temp}$	Input Offset Voltage Drift		●	0.5	2.2		0.6	2.8	$\mu V/^{\circ}C$
$I_{OS}$	Input Offset Current		●	0.2	2.0		0.3	3.0	nA
$I_B$	Input Bias Current		●	9	18		11	27	nA
$A_{VOL}$	Large-Signal Voltage Gain	$V_O = \pm 10V$ , $R_L = 2k$	●	0.5	1.5		0.25	1.0	$V/\mu V$
CMRR	Common Mode Rejection Ratio	$V_{CM} = +13V, -14.9V$	●	97	114		94	113	dB
PSRR	Power Supply Rejection Ratio	$V_S = \pm 2V$ to $\pm 18V$ , $V_O = 0V$	●	100	117		97	116	dB
	Maximum Output Voltage Swing	$R_L = 2k$	●	$\pm 12$	$\pm 13.8$		$\pm 11.5$	$\pm 13.8$	V
$I_S$	Supply Current		●	400	650		400	750	$\mu A$

The ● denotes the specifications which apply over the full operating temperature range.  $V_S = \pm 15V$ ,  $0^{\circ}C \leq T_A \leq 70^{\circ}C$ , unless otherwise noted.

SYMBOL	PARAMETER	CONDITIONS	LT1006AC			LT1006C			UNITS
			MIN	TYP	MAX	MIN	TYP	MAX	
$V_{OS}$	Input Offset Voltage	J8/H Package N8 Package S8 Package	● ● ●	50	200		75 80 150	300 330 730	$\mu V$ $\mu V$ $\mu V$
$\frac{\Delta V_{OS}}{\Delta Temp}$	Input Offset Voltage Drift	J8/H Package N8 Package S8 Package	● ● ●	0.5	2.2		0.6 0.7 1.0	2.8 3.5 4.5	$\mu V/^{\circ}C$ $\mu V/^{\circ}C$ $\mu V/^{\circ}C$
$I_{OS}$	Input Offset Current		●	0.15	1		0.25	2	nA
$I_B$	Input Bias Current		●	8	15		10	23	nA
$A_{VOL}$	Large-Signal Voltage Gain	$V_O = \pm 10V$ , $R_L = 2k$	●	1	3		0.7	2.5	$V/\mu V$
CMRR	Common Mode Rejection Ratio	$V_{CM} = 13V, -15V$	●	98	116		94	114	dB
PSRR	Power Supply Rejection Ratio	$V_S = \pm 2V$ to $\pm 18V$ , $V_O = 0V$	●	101	120		97	118	dB
	Maximum Output Voltage Swing	$R_L = 2k$	●	$\pm 12.5$	$\pm 13.9$		$\pm 11.5$	$\pm 13.8$	V
$I_S$	Supply Current		●	370	600		380	660	$\mu A$

**Note 1:** Absolute Maximum Ratings are those values beyond which the life of a device may be impaired.

**Note 2:** This parameter is guaranteed by design and is not tested.

**Note 3:** Regular operation does not require an external resistor. In order to program the supply current for low power or high speed operation, connect an external resistor from Pin 8 to Pin 7 or from Pin 8 to Pin 4, respectively. Supply current specifications (for  $R_{SET} = 180k$ ) do not include current in  $R_{SET}$ .

**Note 4:** Optional offset nulling is accomplished with a potentiometer connected between the trim terminals and the wiper to  $V^-$ . A 10k pot (providing a null range of  $\pm 6mV$ ) is recommended for minimum drift of nulled offset voltage with temperature. For increased trim resolution and accuracy, two fixed resistors can be used in conjunction with a smaller potentiometer. For example, two 4.7k resistors tied to Pins 1 and 5, with a 500 $\Omega$  pot in the middle, will have a null range of  $\pm 150\mu V$ .

TYPICAL PERFORMANCE CHARACTERISTICS

Offset Voltage Drift with Temperature of Representative Units

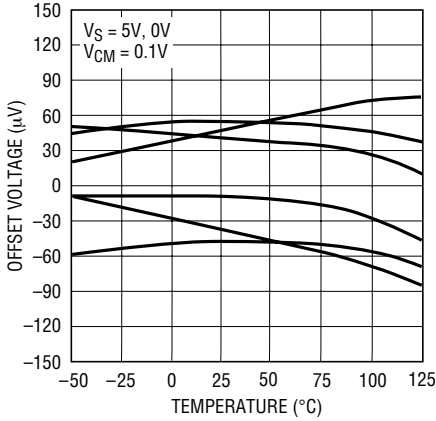

LT1006 • G02

Offset Voltage vs Balanced Source Resistor

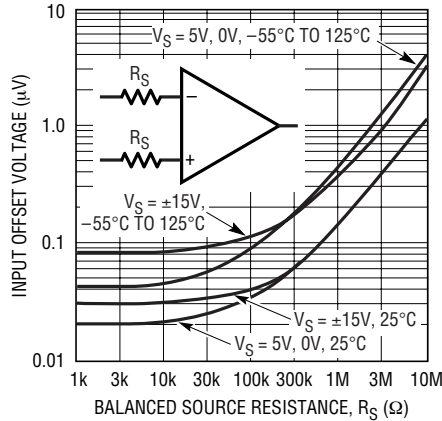

LT1006 • G03

$V_{OS}$  vs Common Mode Voltage vs Temperature

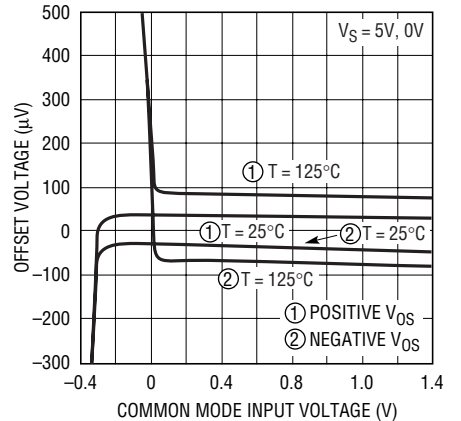

LT1006 • G04

Warm-Up Drift

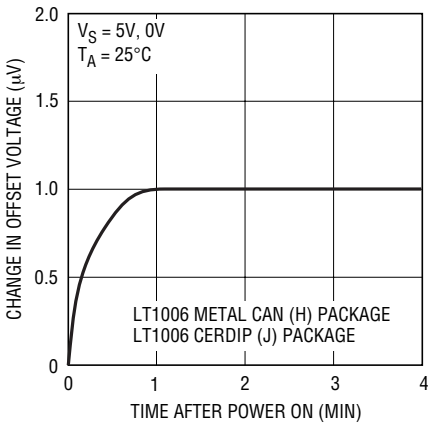

LT1006 • G05

Voltage Gain vs Load Resistance,  $V_S = 5V, 0V$

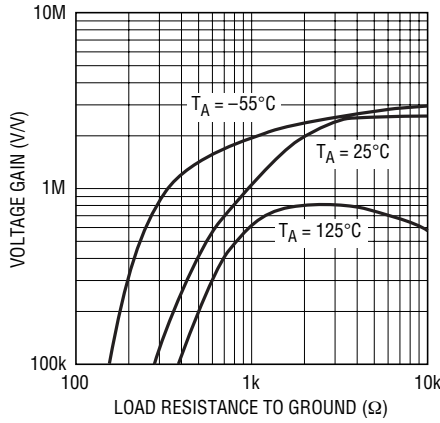

LT1006 • G06

Voltage Gain vs Load Resistance with  $V_S = \pm 15V$

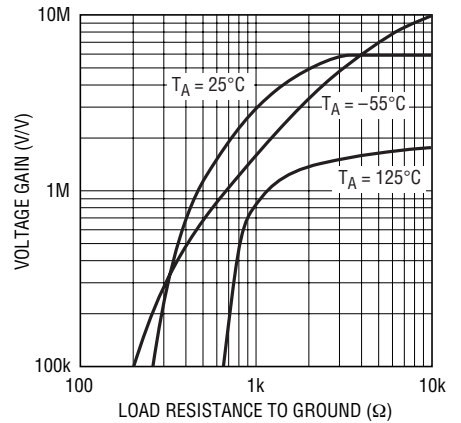

LT1006 • G07

Input Bias Current vs Temperature

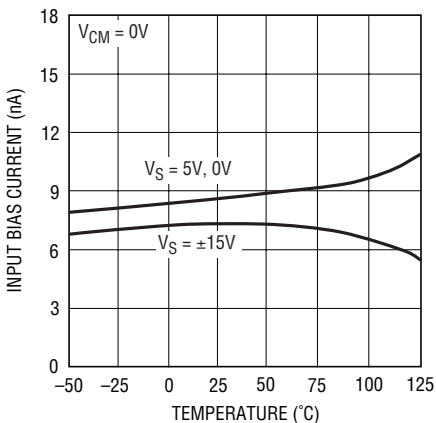

LT1006 • G08

Input Offset Current vs Temperature

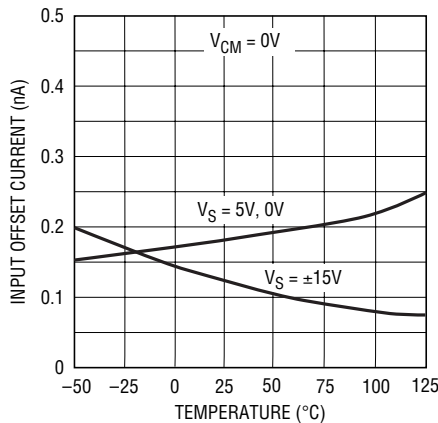

LT1006 • G09

Input Bias Current vs Common Mode Voltage

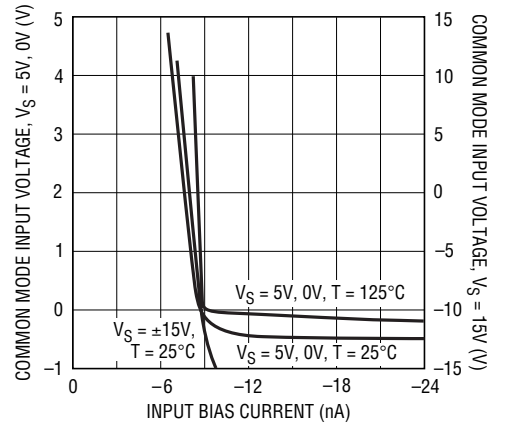

LT1006 • G10

# TYPICAL PERFORMANCE CHARACTERISTICS

10Hz Voltage Noise Distribution

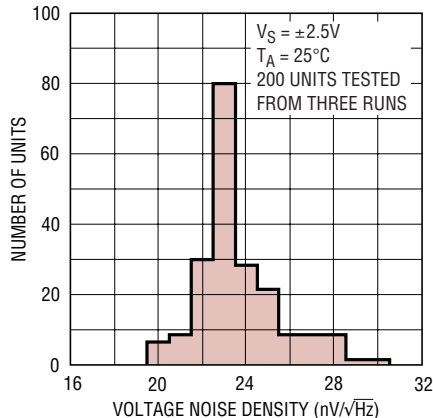

LT1006 • G11

Noise Spectrum

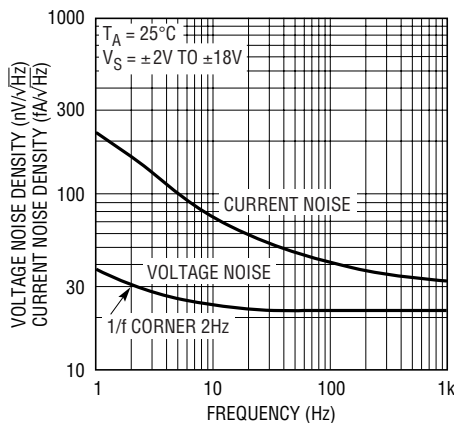

LT1006 • G12

0.1Hz to 10Hz Noise

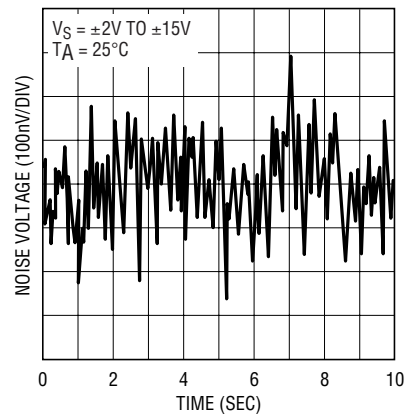

LT1006 • G13

Supply Current vs Temperature

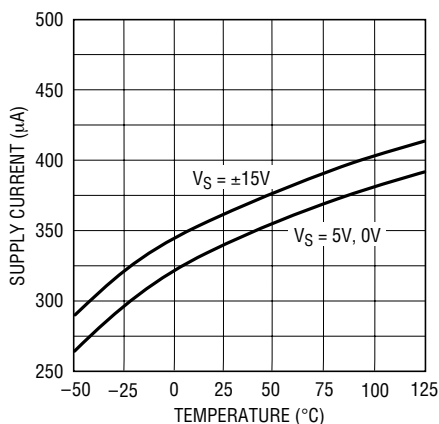

LT1006 • G14

Reducing Power Dissipation

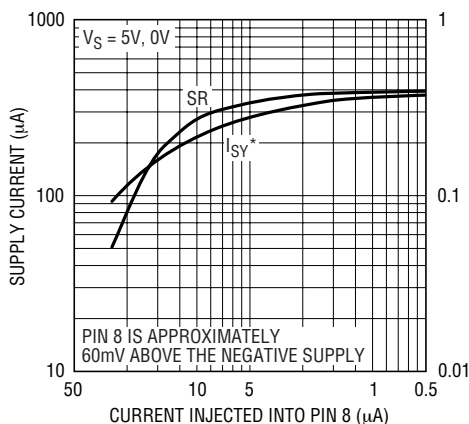

\* $I_{SY}$  DOES NOT INCLUDE CURRENT THROUGH  $R_{SET}$

LT1006 • G15

Increasing Slew Rate ( $R_{SET}$  to  $V^-$ )

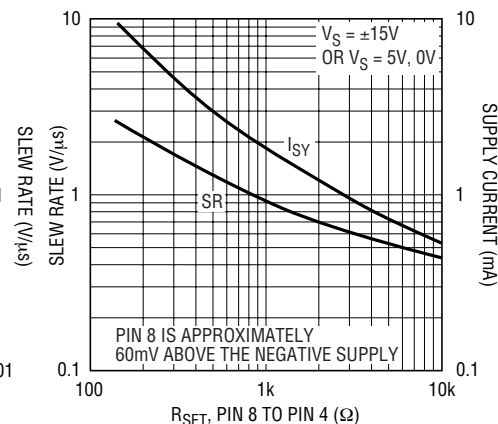

LT1006 • G16

Output Saturation vs Sink Current vs Temperature

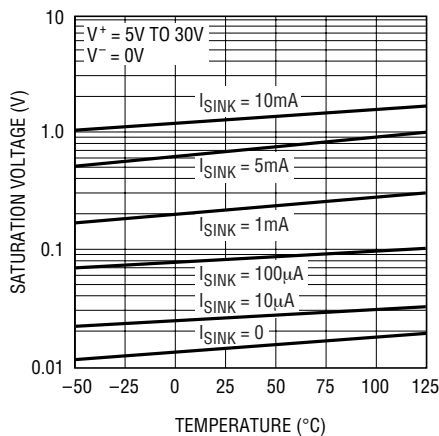

LT1006 • G17

Maximum Output Swing vs Load Resistor

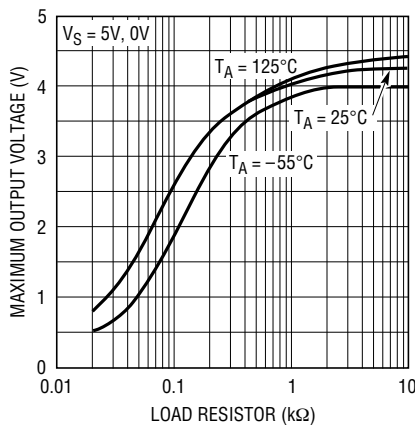

LT1006 • G18

Common Mode Rejection Ratio vs Frequency

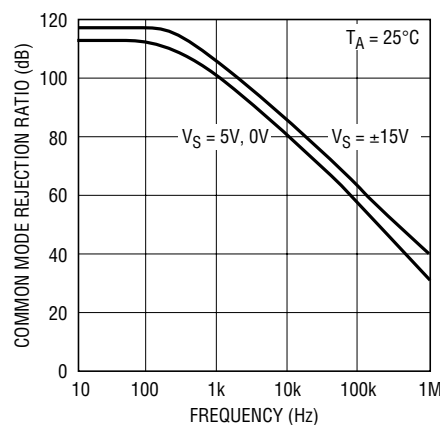

LT1006 • G19

# TYPICAL PERFORMANCE CHARACTERISTICS

**Voltage Gain vs Frequency**

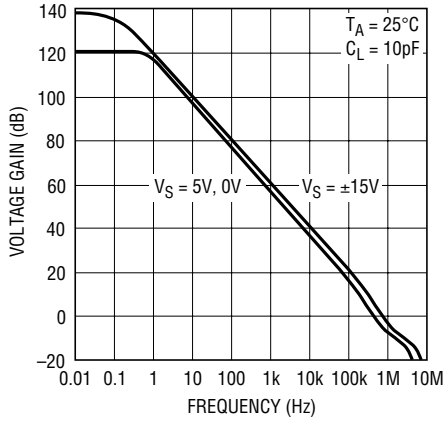

LT1006 • G20

**Gain, Phase vs Frequency**

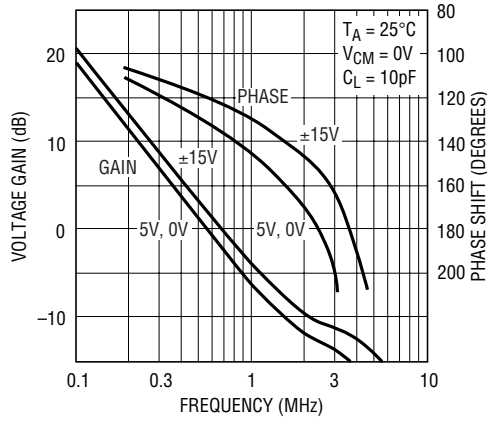

LT1006 • G21

**Power Supply Rejection Ratio vs Frequency**

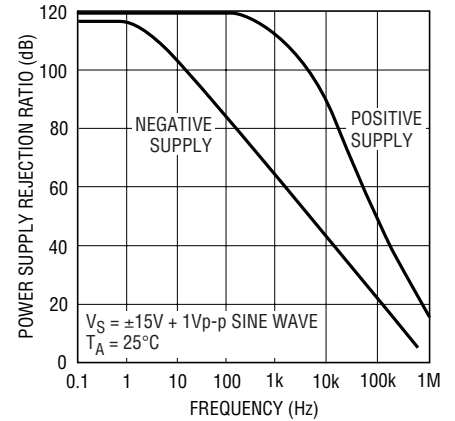

LT1006 • G22

**Large Transient Response, VS = 5V, 0V**

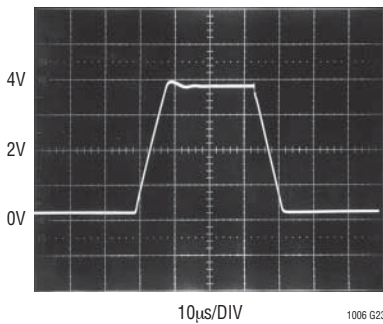

AV = 1  
RL = 4.7k TO 5V  
INPUT = 0V TO 3.8V

**Large-Signal Transient Response, VS = 5V, 0V**

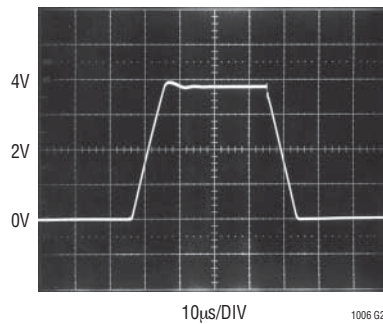

AV = 1  
RL = 4.7k TO GROUND  
INPUT = 0V TO 3.8V

**Large-Signal Transient Response, VS = ±15V**

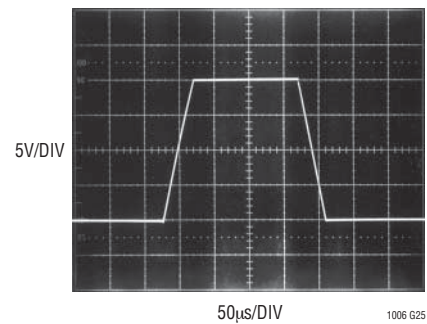

AV = 1

**Small-Signal Transient Response, VS = 5V, 0V**

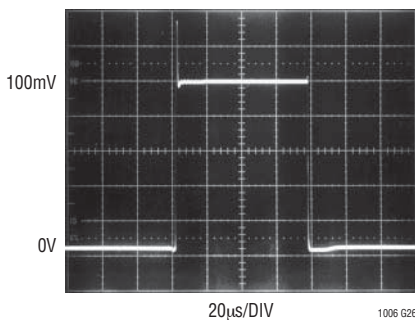

AV = 1  
CL = 10pF  
RL = 600Ω TO GND  
INPUT = 0V TO 100mV PULSE

**Small-Signal Transient Response, VCC = ±2.5V to ±15V**

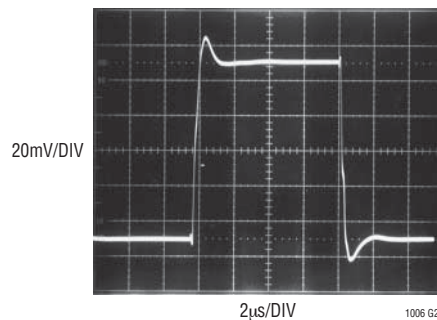

AV = 1  
CL = 10pF



## APPLICATIONS INFORMATION

The LT1006 is fully specified for single supply operation, (i.e., when the negative supply is 0V). Input common mode range includes ground; the output swings within a few millivolts of ground. Single supply operation, however, can create special difficulties, both at the input and at the output. The LT1006 has specific circuitry which addresses these problems.

At the input, the driving signal can fall below 0V— inadvertently or on a transient basis. If the input is more than a few hundred millivolts below ground, two distinct problems can occur on previous single supply designs, such as the LM124, LM158, OP-20, OP-21, OP-220, OP-221, OP-420:

- a) When the input is more than a diode drop below ground, unlimited current will flow from the substrate ( $V^-$  terminal) to the input. This can destroy the unit. On the LT1006, the 400Ω resistors, in series with the input (see Schematic Diagram), protect the devices even when the input is 5V below ground.
- b) When the input is more than 400mV below ground (at 25°C), the input stage saturates (transistors Q3 and

Q4) and phase reversal occurs at the output. This can cause lock-up in servo systems. Due to a unique phase reversal protection circuitry (Q21, Q22, Q27, Q28), the LT1006's output does not reverse, as illustrated below, even when the inputs are at -1.5V.

At the output, the aforementioned single supply designs either cannot swing to within 600mV of ground (OP-20) or cannot sink more than a few microamperes while swinging to ground (LM124, LM158). The LT1006's all-NPN output stage maintains its low output resistance and high gain characteristics until the output is saturated.

In dual supply operations, the output stage is crossover distortion free.

Since the output cannot go exactly to ground, but can only approach ground to within a few millivolts, care should be exercised to ensure that the output is not saturated. For example, a 1mV input signal will cause the amplifier to set up in its linear region in the gain 100 configuration shown below, but is not enough to make the amplifier function properly in the voltage follower mode.

### Voltage Follower with Input Exceeding the Negative Common Mode Range ( $V_S = 5V, 0V$ )

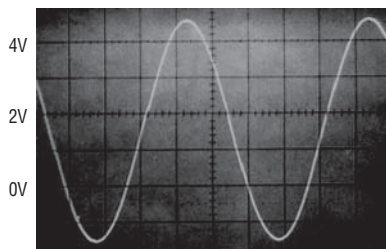

6V<sub>p-p</sub> INPUT, -1.5V TO 4.5V 1006 TA11a

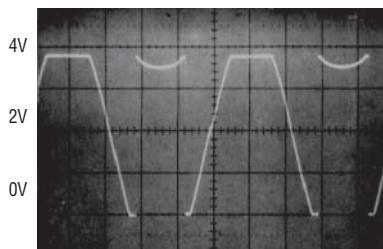

LM324, LM358, OP-20, OP-21  
EXHIBIT OUTPUT PHASE REVERSAL 1006 TA11b

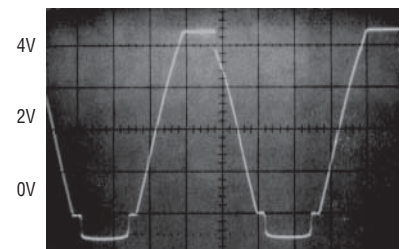

LT1006  
NO PHASE REVERSAL 1006 TA11c

### Gain 100 Amplifier

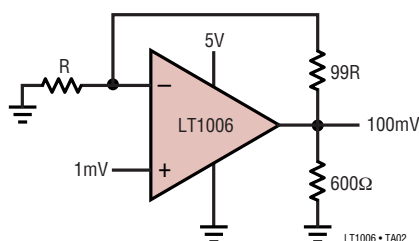

LT1006 • TA02

### Voltage Follower

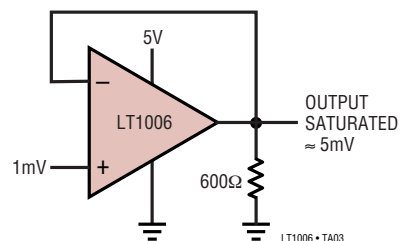

LT1006 • TA03

## APPLICATIONS INFORMATION

In automated production testing the output is forced to 1.4V by the test loop; offset voltage is measured with a common mode voltage of zero and the negative supply at zero (Pin 4). Without the test loop, these exact conditions cannot be achieved. The test circuit shown ensures that the output will never saturate even with worst-case offset voltages ( $-250\mu\text{V}$  over the  $-55^\circ\text{C}$  to  $125^\circ\text{C}$  range). The effective common mode input is 0.3V with respect to the negative supply. As indicated by the common mode rejection specifications the difference is only a few microvolts between the two methods of offset voltage measurement.

**Test Circuit for Offset Voltage and Offset Drift with Temperature**

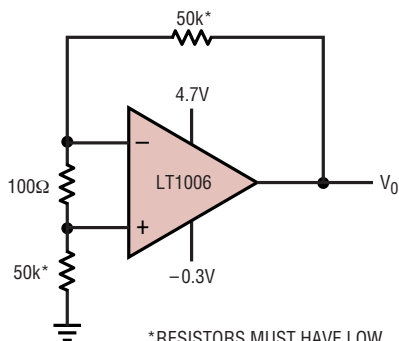

\*RESISTORS MUST HAVE LOW THERMOELECTRIC POTENTIAL.  
 \*\*THIS CIRCUIT IS ALSO USED AS THE BURN-IN CONFIGURATION, WITH SUPPLY VOLTAGES INCREASED TO  $\pm 20\text{V}$   
 $V_0 = 1000V_{OS}$

LT1006 • TA04

### Low Supply Operation

The minimum guaranteed supply voltage for proper operation of the LT1006 is 2.7V. Typical supply current at this voltage is  $320\mu\text{A}$ ; therefore, power dissipation is only  $860\mu\text{W}$ .

### Noise Testing

For application information on noise testing and calculations, please see the LT1007 or LT1028 data sheet.

### Supply Current Programming

Connecting an optional external resistor to Pin 8 changes the biasing of the LT1006 in order to increase its speed or to decrease its power consumption. If a higher slew rate is required, connect the external resistor for Pin 8 to Pin 4 [see performance curves for Increasing Slew Rate ( $R_{SET}$  to  $V^-$ )]. For lower power consumption, inject a current into Pin 8 (which is approximately 60mV above  $V^-$ ) as shown on the Reducing Power Dissipation plot. This can be accomplished by connecting  $R_{SET}$  to the positive supply, or to save additional power, by obtaining the injected current from a low voltage battery.

### Comparator Applications

The single supply operation of the LT1006 and its ability to swing close to ground while sinking current lends itself to use as a precision comparator with TTL compatible output.

**Comparator Rise Response Time to 10mV, 5mV, 2mV Overdrives**

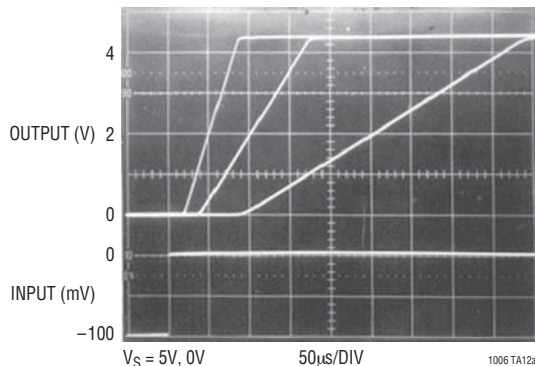

**Comparator Fall Response Time to 10mV, 5mV, 2mV Overdrives**

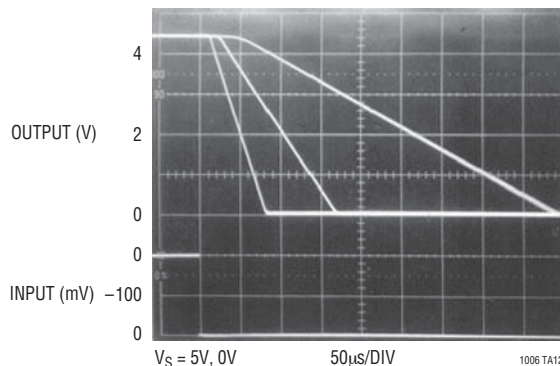



TYPICAL APPLICATIONS

Micropower Thermocouple Signal Conditioner with Cold Junction Compensation

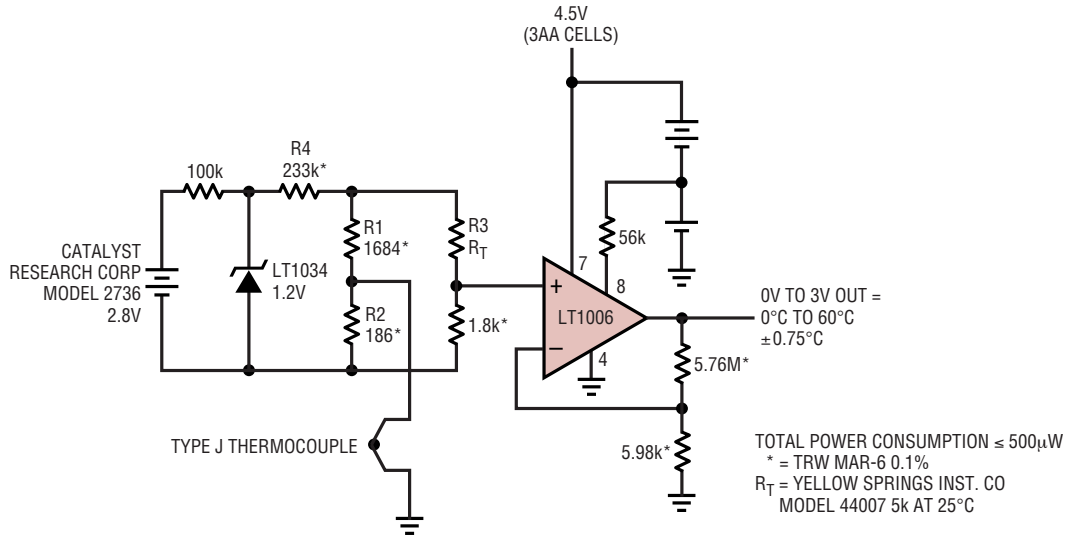

Linear Thermometer

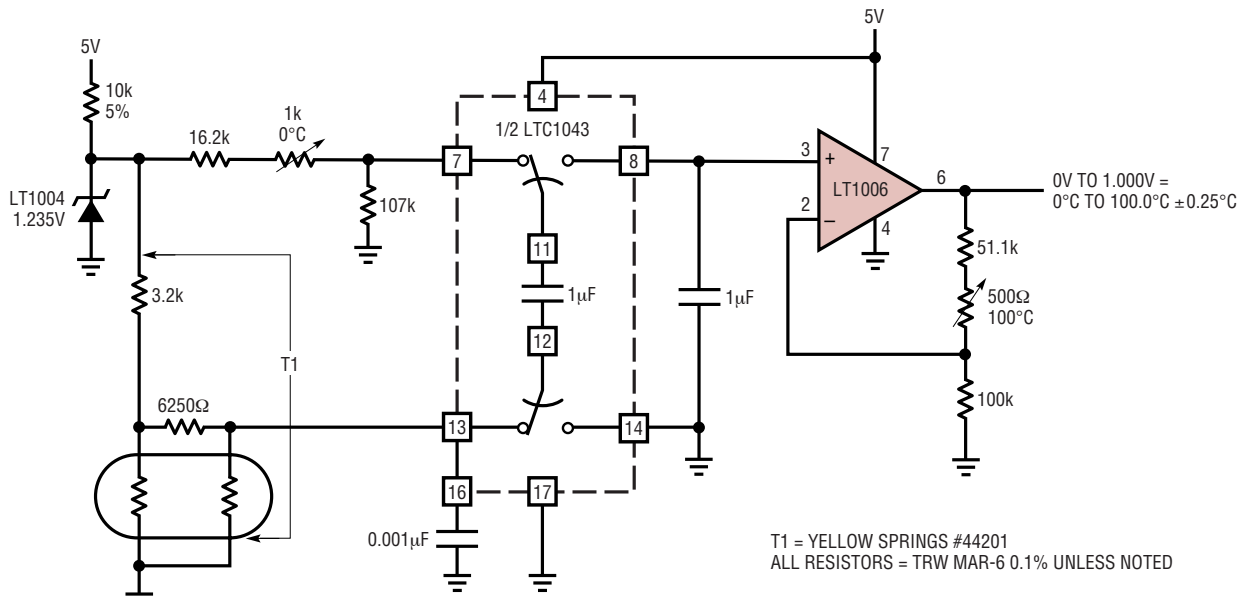

# TYPICAL APPLICATIONS

**±5V Precision Instrumentation Amplifier**

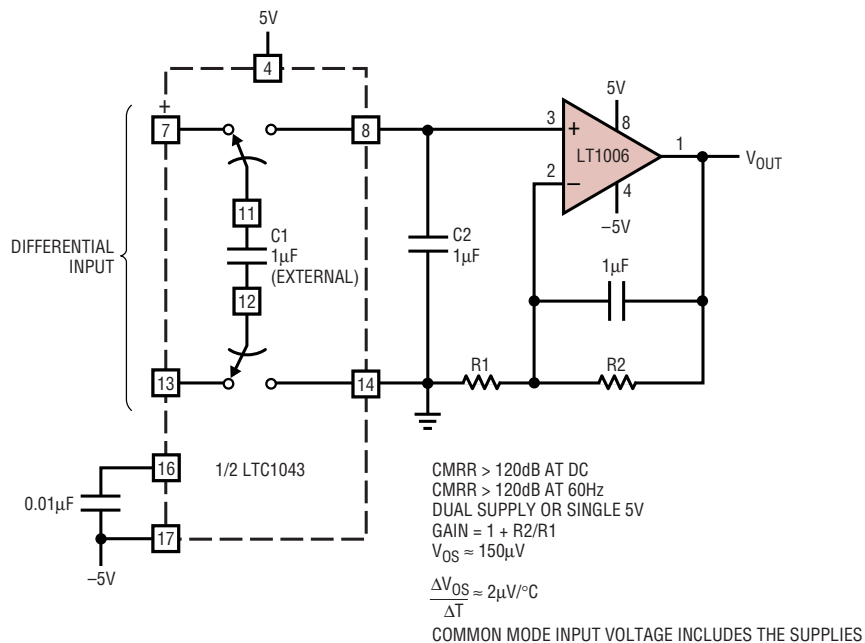

LT1006 • TA10

# SCHEMATIC DIAGRAM

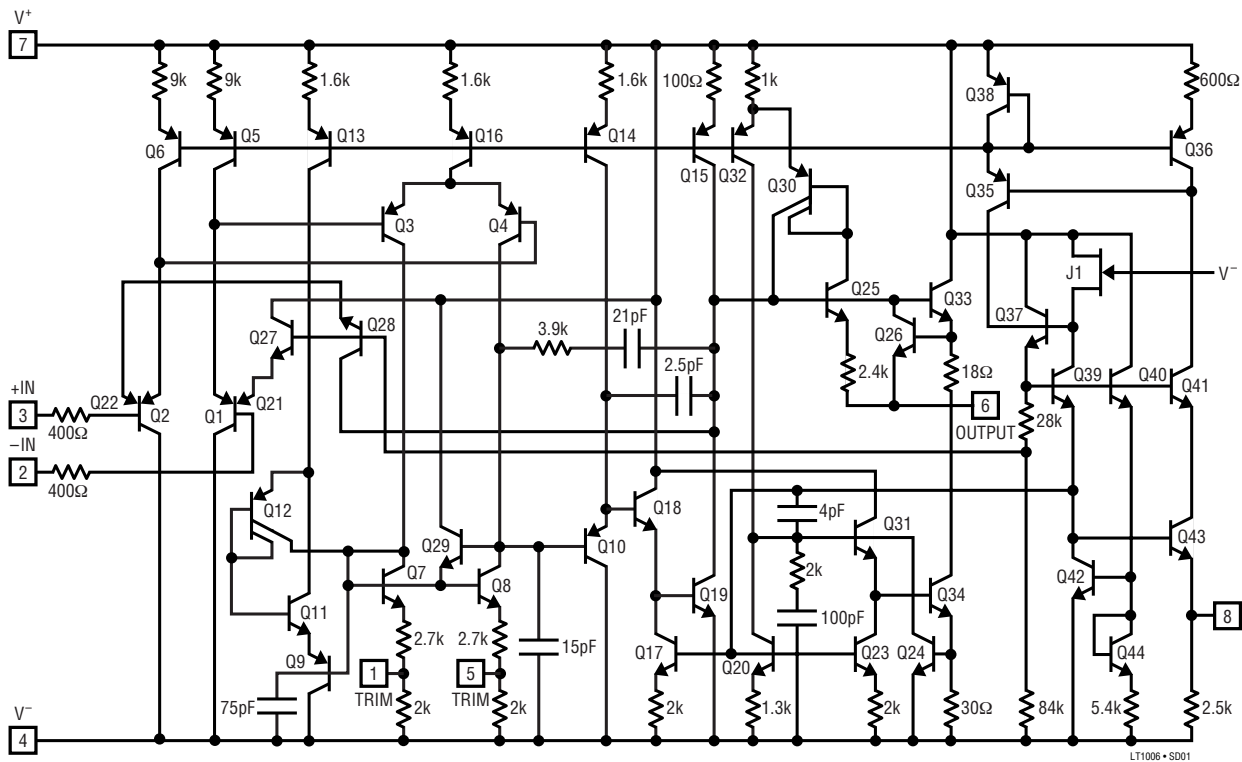

LT1006 • SD01

1006fa



# PACKAGE DESCRIPTION

**N8 Package**  
**8-Lead PDIP (Narrow .300 Inch)**  
 (Reference LTC DWG # 05-08-1510)

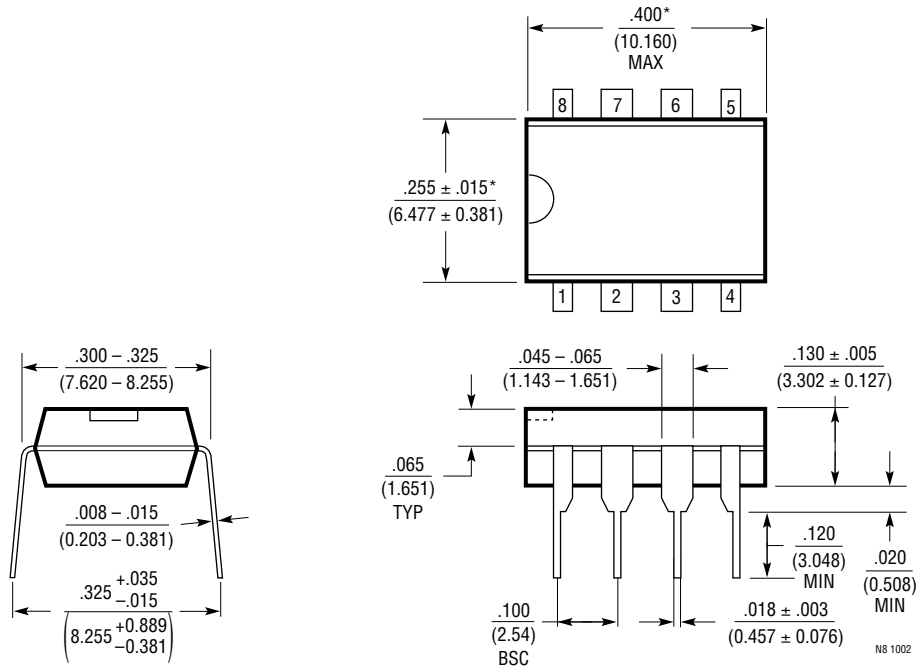

NOTE:  
 1. DIMENSIONS ARE  $\frac{\text{INCHES}}{\text{MILLIMETERS}}$   
 \*THESE DIMENSIONS DO NOT INCLUDE MOLD FLASH OR PROTRUSIONS.  
 MOLD FLASH OR PROTRUSIONS SHALL NOT EXCEED .010 INCH (0.254mm)

N8 1002

**PACKAGE DESCRIPTION**

**S8 Package**  
**8-Lead Plastic Small Outline (Narrow .150 Inch)**  
 (Reference LTC DWG # 05-08-1610)

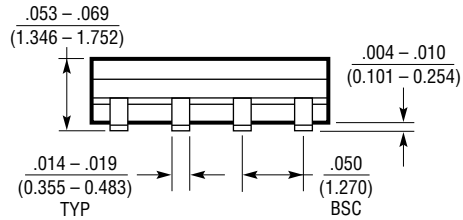
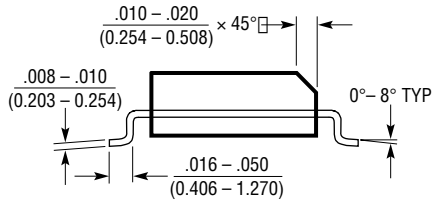
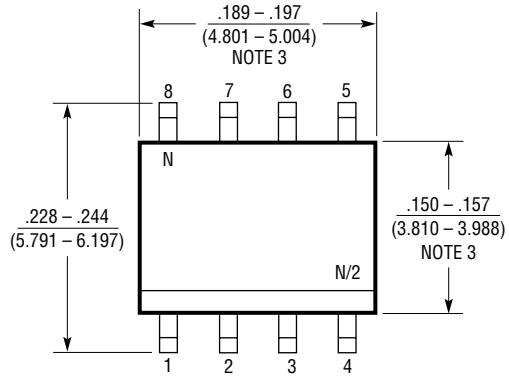
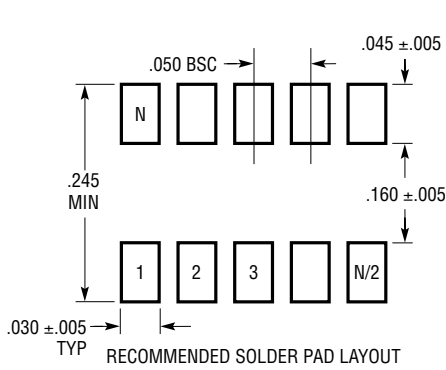

- NOTE:  
 1. DIMENSIONS IN  $\frac{\text{INCHES}}{\text{MILLIMETERS}}$   
 2. DRAWING NOT TO SCALE  
 3. THESE DIMENSIONS DO NOT INCLUDE MOLD FLASH OR PROTRUSIONS.  
 MOLD FLASH OR PROTRUSIONS SHALL NOT EXCEED .006" (0.15mm)

S08 0502





Компания «ЭлектроПласт» предлагает заключение долгосрочных отношений при поставках импортных электронных компонентов на взаимовыгодных условиях!

Наши преимущества:

- Оперативные поставки широкого спектра электронных компонентов отечественного и импортного производства напрямую от производителей и с крупнейших мировых складов;
- Поставка более 17-ти миллионов наименований электронных компонентов;
- Поставка сложных, дефицитных, либо снятых с производства позиций;
- Оперативные сроки поставки под заказ (от 5 рабочих дней);
- Экспресс доставка в любую точку России;
- Техническая поддержка проекта, помощь в подборе аналогов, поставка прототипов;
- Система менеджмента качества сертифицирована по Международному стандарту ISO 9001;
- Лицензия ФСБ на осуществление работ с использованием сведений, составляющих государственную тайну;
- Поставка специализированных компонентов (Xilinx, Altera, Analog Devices, Intersil, Interpoint, Microsemi, Aeroflex, Peregrine, Syfer, Eurofarad, Texas Instrument, Miteq, Cobham, E2V, MA-COM, Hittite, Mini-Circuits, General Dynamics и др.);

Помимо этого, одним из направлений компании «ЭлектроПласт» является направление «Источники питания». Мы предлагаем Вам помощь Конструкторского отдела:

- Подбор оптимального решения, техническое обоснование при выборе компонента;
- Подбор аналогов;
- Консультации по применению компонента;
- Поставка образцов и прототипов;
- Техническая поддержка проекта;
- Защита от снятия компонента с производства.



#### Как с нами связаться

**Телефон:** 8 (812) 309 58 32 (многоканальный)

**Факс:** 8 (812) 320-02-42

**Электронная почта:** [org@eplast1.ru](mailto:org@eplast1.ru)

**Адрес:** 198099, г. Санкт-Петербург, ул. Калинина, дом 2, корпус 4, литера А.