

SINGLE-POLE DOUBLE-THROW ANALOG SWITCH

Description

The 74LVC1G3157 is a single-pole, double-throw analog switch. The device is designed for operation with a power supply range of 1.65V to 5.5V. The bidirectional switch can handle signal amplitudes between Vcc and Ground. The OFF state impedance of the switch is typically 50MΩ while the ON state is typically 6Ω.

Features

- Wide Supply Voltage Range from 1.65 to 5.5V
- Control Pin Includes Hysteresis Allowing for Slower Input Rise and Fall Times
- CMOS Low Power Consumption
- Very Low ON-State Resistance
 - 7.5Ω (typical) at V_{CC} = 2.7V
 - 6.5Ω (typical) at V_{CC} = 3.3V
 - 6Ω (typical) at V_{CC} = 4.5V
- Break Before Make Switching
- Control Input accepts up to 5.5V Regardless of V_{CC}.
- Direct Interface with TTL Levels when V_{CC} = 3.3V
- ESD Protection Tested per JESD 22
 - Exceeds 200-V Machine Model (A115)
 - Exceeds 2,000-V Human Body Model (A114)
 - Exceeds 1,000-V Charged Device Model (C101)
- Latch-Up Exceeds 100mA per JESD 78, Class I
- Range of Package Options
- **Totally Lead-Free & Fully RoHS Compliant (Notes 1 & 2)**
- **Halogen and Antimony Free. "Green" Device (Note 3)**

Pin Assignments

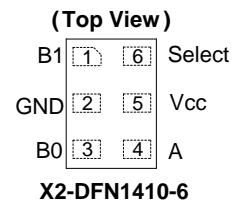
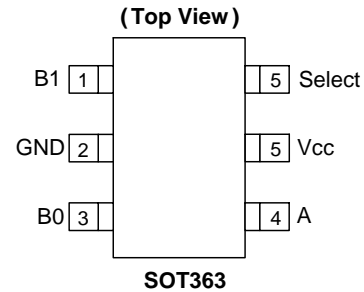

Packages not to scale

Applications

- Multiplexing of Analog Signals
- Multiplexing of Digital Signals
- Wide array of products such as:
 - Tablets, E-readers, Wearables
 - Cell Phones, Personal Navigation / GPS
 - MP3 Players, Cameras, Video Recorders
 - Computer Peripherals, Hard Drives, CD/DVD ROMs
 - TV, DVD, DVR, Set Top Boxes
 - PCs, Networking, Notebooks, Netbooks, PDAs

Notes: 1. No purposely added lead. Fully EU Directive 2002/95/EC (RoHS) & 2011/65/EU (RoHS 2) compliant.
 2. See http://www.diodes.com/quality/lead_free.html for more information about Diodes Incorporated's definitions of Halogen- and Antimony-free, "Green" and Lead-free.
 3. Halogen- and Antimony-free "Green" products are defined as those which contain <900ppm bromine, <900ppm chlorine (<1500ppm total Br + Cl) and <1000ppm antimony compounds.

Ordering Information (Note 4)

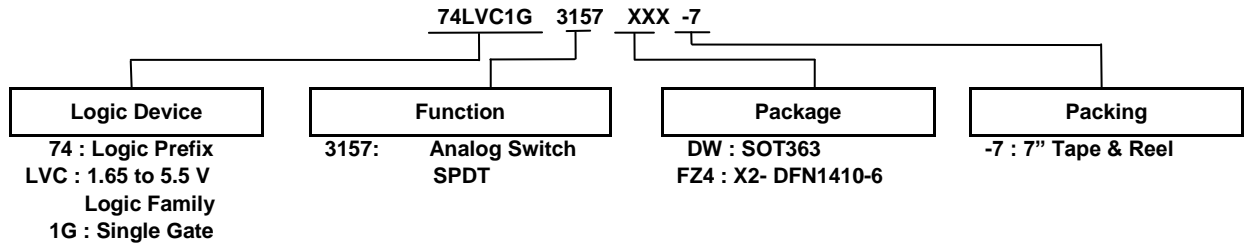

Device	Package Code	Package (Note 5)	Package Size	7" Tape and Reel (Note 6)	
				Quantity	Part Number Suffix
74LVC1G3157DW-7	DW	SOT363	2.0mm x 2.0mm x 1.1mm 0.65 mm lead pitch	3,000/Tape & Reel	-7
74LVC1G3157FZ4-7	FZ4	X2-DFN1410-6	1.4mm x 1.0mm x 0.4mm 0.5 mm pad pitch	5,000/Tape & Reel	-7

- Notes:
4. For packaging details, go to our website at <http://www.diodes.com/products/packages.html>.
 5. Pad layout as shown in Diodes Incorporated's package outline PDFs, which can be found on our website at <http://www.diodes.com/package-outlines.html>.
 6. The taping orientation is located on our website at <http://www.diodes.com/datasheets/ap02007.pdf>.

Pin Descriptions

Pin Name	Description
B1	Selectable Data I/O
GND	Ground
B0	Selectable Data I/O
A	Common Data I/O
V _{CC}	Supply Voltage
Select	Selection Pin

Logic Diagram

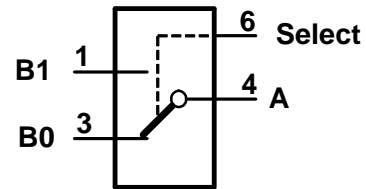

Function Table

Select	Status
H	B1 connected to A; B0 high impedance
L	B0 connected to A; B1 high impedance

Simplified Schematic

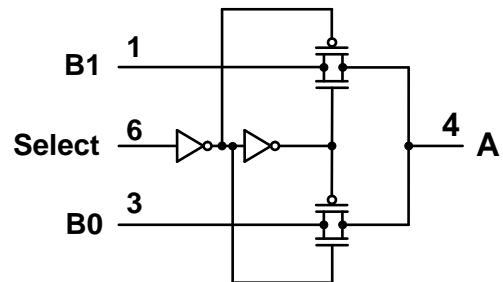

Absolute Maximum Ratings (Note 7)

Symbol	Description	Rating	Unit
ESD HBM	Human Body Model ESD Protection	2	kV
ESD CDM	Charged Device Model ESD Protection	1	kV
ESD MM	Machine Model ESD Protection	200	V
V_{CC}	Supply Voltage Range	-0.5 to 6.5	V
V_{IN}	Input Voltage Range Applicable to Select Pin	-0.5 to 6.5	V
V_{SW}	Voltage Range Applicable to B0, B1, and A Pins	-0.5 to $V_{CC}+0.5$	V
I_{IK}	Input Clamp Current $V_I < 0$ Applicable to Select Pin	-50	mA
I_{IO}	Continuous Current Applicable to B0, B1, and A Pins	± 50	mA
I_{CC}, I_{GND}	Continuous current through V_{CC} or GND	± 100	mA
T_J	Operating Junction Temperature	-40 to +150	$^{\circ}C$
T_{STG}	Storage Temperature	-65 to +150	$^{\circ}C$

Note: 7. Stresses beyond the absolute maximum may result in immediate failure or reduced reliability. These are stress values and device operation should be within recommend values.

Recommended Operating Conditions

Symbol	Parameter		Min	Max	Unit
V_{CC}	Operating Voltage	Operating	1.65	5.5	V
V_{IN}	Select Input Voltage		0	5.5	V
V_{SW}	Switch Voltage (applicable to pins B0, B1, A)		-0.2	V_{CC}	V
$\Delta t/\Delta V$	Input Transition Rise or Fall Rate – Select Pin	$V_{CC} = 1.65$ to $2.7V$	-	20	ns/V
		$V_{CC} = 2.7V$ to $5.5V$	-	10	
T_A	Operating Free-Air Temperature	-	-40	+125	$^{\circ}C$

Electrical Characteristics (All typical values are at, $T_J = +25^\circ\text{C}$)

Symbol	Parameter	Test Condition	V_{CC} (V)	$T_A = -40$ to $+85^\circ\text{C}$			$T_A = -40$ to $+125^\circ\text{C}$		Unit
				Min	Typical (Note 8)	Max	Min	Max	
V_{IH}	High Level Input Voltage Select Pin	-	1.65 to 1.95	$0.65V_{CC}$	-	-	$0.65V_{CC}$	-	V
			2.3 to 2.7	1.7	-	-	1.7	-	
			3 to 3.6	2.0	-	-	2.0	-	
			4.5 to 5.5	$0.7V_{CC}$	-	-	$0.7V_{CC}$	-	
V_{IL}	Low Level Input Voltage Select Pin	-	1.65 to 1.95	-	-	$0.35V_{CC}$	-	$0.35V_{CC}$	V
			2.3 to 2.7	-	-	0.7	-	0.7	
			3 to 3.6	-	-	0.8	-	0.8	
			4.5 to 5.5	-	-	$0.3V_{CC}$	-	$0.3V_{CC}$	
I_{IN}	Input Leakage Current Select Pin	$0 \leq \text{Select} \leq 5.5V$	0 to 5.5	-	± 0.05	± 1	-	± 10	μA
$I_{S(OFF)}$	OFF State Leakage Current	$0V \leq A, B_n \leq V_{CC}$ Figure 1	1.65 to 5.5	-	± 0.05	± 1	-	± 10	μA
$I_{S(ON)}$	ON State Leakage Current	$0V \leq A, B_n \leq V_{CC}$ Figure 2	1.65 to 5.5	-	± 0.05	± 1	-	± 10	μA
$I_{S(ON)}$	ON State Leakage Current	$-0.1V \leq A, B_n \leq V_{CC}$ Figure 2	1.65 to 5.5	-	± 0.05	± 2	-	± 20	μA
I_{CC}	Quiescent Supply Current	Select = V_{CC} or GND A, B _n = V_{CC} or GND $I_{OUT} = 0$	5.5	-	1.0	10	-	40	μA
ΔI_{CC}	Additional Supply Current	Select = $V_{CC} - 0.6V$ A, B _n = V_{CC} or GND $I_{OUT} = 0$	5.5	-	30	500	-	5,000	μA
C_I	Input Capacitance Select Pin	-	3.3	-	2.5	-	-	-	pF
$C_{S(OFF)}$	OFF State Capacitance	Select = V_{CC} or GND A, B _n = V_{CC} or GND $I_{OUT} = 0$	3.3	-	6.0	-	-	-	pF
$C_{S(ON)}$	ON State Capacitance	Select = V_{CC} or GND A, B _n = V_{CC} or GND $I_{OUT} = 0$	3.3	-	18	-	-	-	pF

Note: 8. Typical performance information is included in figures 11 to 34 on pages 11 to 14.

Electrical Characteristics (All typical values are at $T_J = +25^\circ\text{C}$)

Symbol	Parameter	Test Condition (Note 9)	V_{CC} (V)	$T_A = -40$ to $+85^\circ\text{C}$			$T_A = -40$ to $+125^\circ\text{C}$		Unit
				Min	Typ	Max	Min	Max	
R_{ON}	ON Resistance	$V_I = 0\text{V}, I_O = 4\text{mA}$	1.65	-	12.5	18	-	27	Ω
		$V_I = 1.65\text{V}, I_O = -4\text{mA}$		-	14	18	-	35	
		$V_I = 0\text{V}, I_O = 8\text{mA}$	2.3	-	9.0	16	-	24	
		$V_I = 2.3\text{V}, I_O = -8\text{mA}$		-	9.0	2016	-	30	
		$V_I = 0\text{V}, I_O = 12\text{mA}$	2.7	-	8.0	14	-	21	
		$V_I = 2.7\text{V}, I_O = -12\text{mA}$		-	8.0	14	-	27	
		$V_I = 0\text{V}, I_O = 24\text{mA}$	3.0	-	7.0	12	-	18	
		$V_I = 3.0\text{V}, I_O = -24\text{mA}$		-	7.0	12	-	23	
		$V_I = 0\text{V}, I_O = 32\text{mA}$	4.5	-	5.5	10	-	15	
		$V_I = 2.7\text{V}, I_O = -32\text{mA}$		-	6.0	12	-	17	
$V_I = 4.5\text{V}, I_O = -32\text{mA}$	-	5.5		10	-	15			
R_{RANGE}	On Resistance Over Signal Range	$I_A = 4\text{mA}, 0 \leq V_{BN} \leq V_{CC}$	1.65	-	34	130	-	195	Ω
		$I_A = 8\text{mA}, 0 \leq V_{BN} \leq V_{CC}$	2.3	-	5	30	-	45	
		$I_A = 12\text{mA}, 0 \leq V_{BN} \leq V_{CC}$	2.7	-	4	25	-	38	
		$I_A = 24\text{mA}, 0 \leq V_{BN} \leq V_{CC}$	3.0	-	7.8	20	-	30	
		$I_A = 32\text{mA}, 0 \leq V_{BN} \leq V_{CC}$	4.5	-	6.2	15	-	23	
ΔR_{ON}	On Resistance Match Between Channels (Note 10)	$I_A = -4\text{mA}, V_{BN} = 1.15\text{V}$	1.65	-	0.25	-	-	-	Ω
		$I_A = -8\text{mA}, V_{BN} = 1.6\text{V}$	2.3	-	0.25	-	-	-	
		$I_A = -12\text{mA}, V_{BN} = 1.9\text{V}$	2.7	-	0.25	-	-	-	
		$I_A = -24\text{mA}, V_{BN} = 2.1\text{V}$	3.0	-	0.25	-	-	-	
R_{flat}	On Resistance Flatness (Note 11)	$I_A = -4\text{mA}, 0 \leq V_{BN} \leq V_{CC}$	1.65	-	26	110	-	150	Ω
		$I_A = -8\text{mA}, 0 \leq V_{BN} \leq V_{CC}$	2.3	-	5.0	26	-	105	
		$I_A = -24\text{mA}, 0 \leq V_{BN} \leq V_{CC}$	2.7	-	3.5	16	-	35	
		$I_A = -24\text{mA}, 0 \leq V_{BN} \leq V_{CC}$	3.3	-	2.0	9	-	15	
		$I_A = -32\text{mA}, 0 \leq V_{BN} \leq V_{CC}$	5.0	-	1.5	4	-	8	

Note: 9. Switch resistance test is measured per Figure 3.

10. ΔR_{ON} is measured at identical V_{CC} , temperature and voltage levels.

11. Flatness is defined as the difference between the maximum and minimum of ON resistance measured at identical V_{CC} and temperature.

Switching Characteristics

Symbol	Parameter	Test Condition	V _{CC} Volts	T _A = -40 to +85°C			T _A = -40 to +125°C		Unit	Figure Number
				Min	Typ	Max	Min	Max		
t _{PHL} t _{PLH}	Propagation Delay A to B _n	V _I = OPEN (Note 12)	1.65 to 1.95	-	-	2.0	-	3.0	ns	Figure 4
			2.3 to 2.7	-	-	1.2	-	2.0		
			2.7	-	-	1.0	-	1.5		
			3.0 to 3.6	-	-	0.8	-	1.5		
			4.5 to 5.5	-	-	0.6	-	1.0		
t _{PZL} t _{PZH}	Output Enable Time Switch to B _n	V _I = 2 x V _{CC} for t _{PZL} V _I = 0V for t _{PZH} (Note 13)	1.65 to 1.95	1.0	8.7	14.0	1.0	14.0	ns	Figure 4
			2.3 to 2.7	1.0	5.3	7.5	1.0	7.5		
			2.7	1.0	4.9	6.0	1.0	6.0		
			3.0 to 3.6	0.5	4.0	5.5	0.5	5.5		
			4.5 to 5.5	0.5	3.0	4.0	0.5	4.0		
t _{PLZ} t _{PHZ}	Output Disable Time Switch to B _n	V _I = 2 x V _{CC} for t _{PLZ} V _I = 0V for t _{PHZ} (Note 13)	1.65 to 1.95	2.5	6.0	8.5	2.5	8.5	ns	Figure 4
			2.3 to 2.7	2.0	4.4	8.2	2.0	8.2		
			2.7	1.5	4.2	8.0	1.5	8.0		
			3.0 to 3.6	1.5	3.6	7.8	1.5	7.8		
			4.5 to 5.5	0.8	2.9	7.5	0.8	7.5		
t _{B-M}	Break Before Make Time (Note 9)	-	1.65 to 1.95	0.5	-	-	0.5	-	ns	Figure 5
			2.3 to 2.7	0.5	-	-	0.5	-		
			2.7	0.5	-	-	0.5	-		
			3.0 to 3.6	0.5	-	-	0.5	-		
			4.5 to 5.5	0.5	-	-	0.5	-		
Q	Charge Injection (Note 9)	C _L = 0.1 nF, V _{GEN} = 0V R _{GEN} = 0 Ω	5.0	-	7.0	-	-	-	pC	Figure 6
			3.3	-	3.0	-	-	-		
QIRR	Off Isolation (Note 11)	R _L = 50 Ω, f = 10MHz	1.65 ~ 5.5	-	-42	-	-	-	dB	Figure 7
Xtalk	Crosstalk	R _L = 50 Ω, f = 10MHz	1.65 ~ 5.5	-	-42	-	-	-	dB	Figure 8
BW	-3dB Bandwidth	R _L = 50 Ω	1.65 ~ 5.5	-	300	-	-	-	MHz	Figure 9
THD	Total Harmonic Distortion (Note 9)	R _L = 600 Ω, 0.5 V _{P-P} , f = 600Hz to 20kHz	5.0	-	0.1	-	-	-	%	Figure 10

- Notes:
- Due to the symmetry of the part, the direction of the propagation delay applies to either direction A to B_n or B_n to A. Propagation time is the calculated RC time constant of the typical ON resistance of the switch and the specified load capacitance when capacitance when driven by an ideal voltage source.
 - The Switch signal enable and disables time are the same for B_n and A if they are reversed at input and output.

Parameter Measurement Information

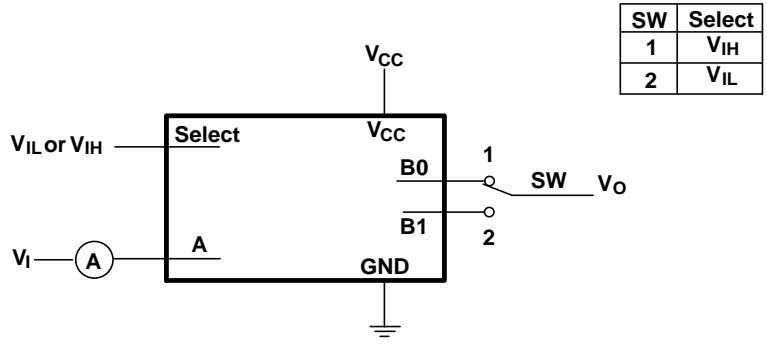

Condition 1: V_I = GND, V_O = V_{CC}
 Condition 2: V_I = V_{CC}, V_O = GND

Figure 1 OFF –State Leakage Current Test

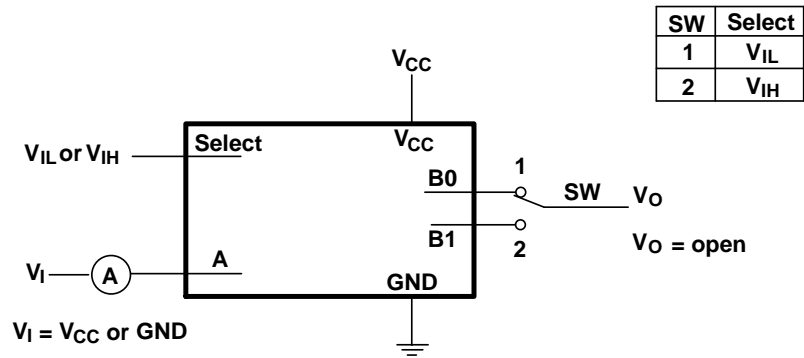

Figure 2 ON –State Leakage Current Test

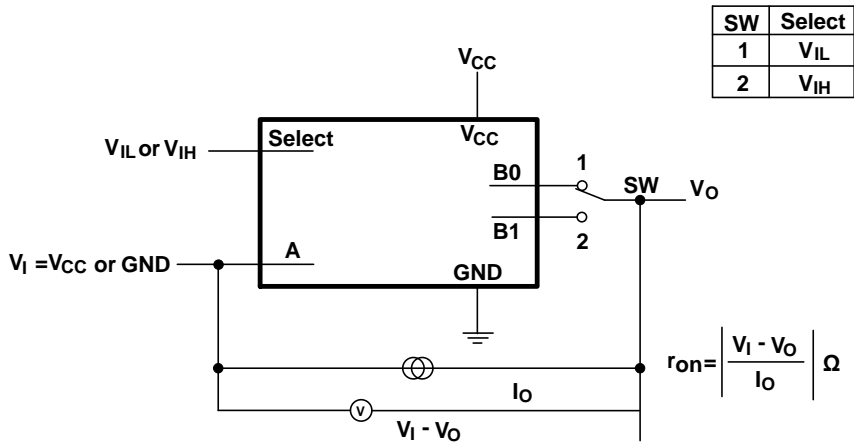
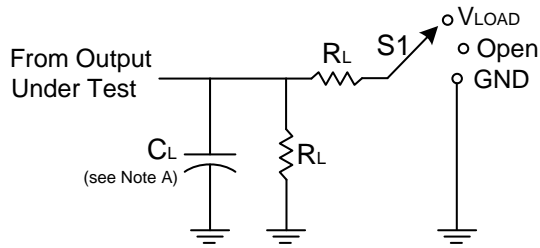

Figure 3 ON State Resistance Test

Parameter Measurement Information (Notes 15-19)



TEST	S1	RL
t_{PLH}/t_{PHL}	Open	500Ω
t_{PLZ}/t_{PZL}	Vload	500Ω
t_{PHZ}/t_{PZH}	GND	500Ω

Vcc	Inputs		VM	VLOAD	CL (Note 14)	VΔ
	VI	tr/td				
1.8V ± 0.15V	VCC	≤2ns	VCC/2	2 x VCC	50pF	0.1V
2.5V ± 0.2V	VCC	≤2ns	VCC/2	2 x VCC	50pF	0.1V
3.3V ± 0.3V	VCC	≤2.5ns	VCC/2	2 x VCC	50pF	0.1V
5V ± 0.5V	VCC	≤2.5ns	VCC/2	2 x VCC	50pF	0.1V

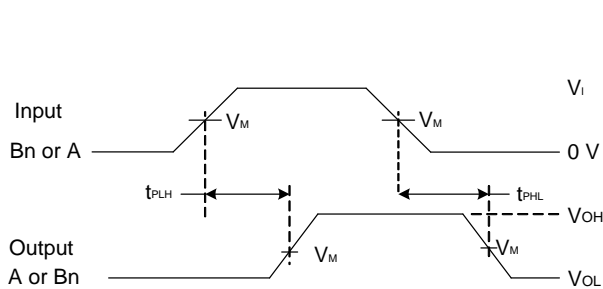

Voltage Waveform Propagation Delay Times

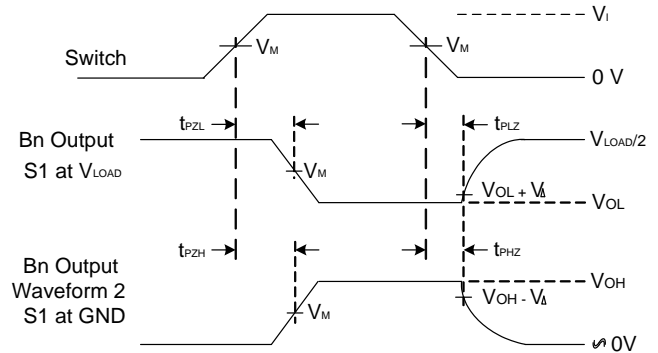

Voltage Waveform Enable and Disable Times

Figure 4 Load Circuit and Voltage Waveforms

- Notes:
- 14. Includes test lead and test apparatus capacitance.
 - 15. All pulses are supplied at pulse repetition rate ≤ 10MHz.
 - 16. Inputs are measured separately one transition per measurement.
 - 17. t_{PLZ} and t_{PHZ} are the same as t_{dis} .
 - 18. t_{PZL} and t_{PZH} are the same as t_{EN} .
 - 19. t_{PLH} and t_{PHL} are the same as t_{PD} .

Parameter Measurement Information (continued)

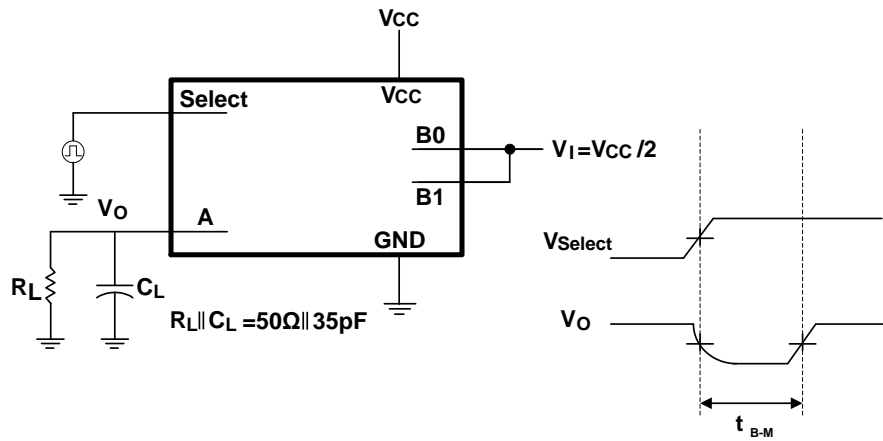

Figure 5 Break before Make Timing Test

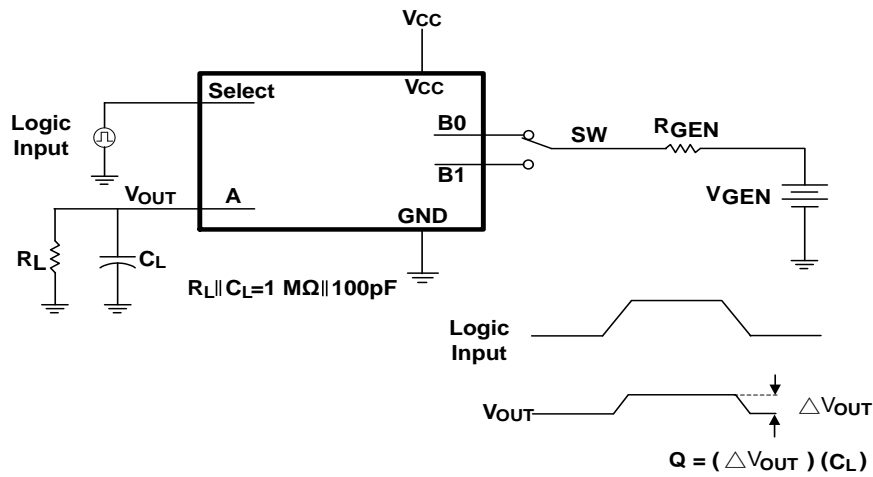

Figure 6 Charge Injection

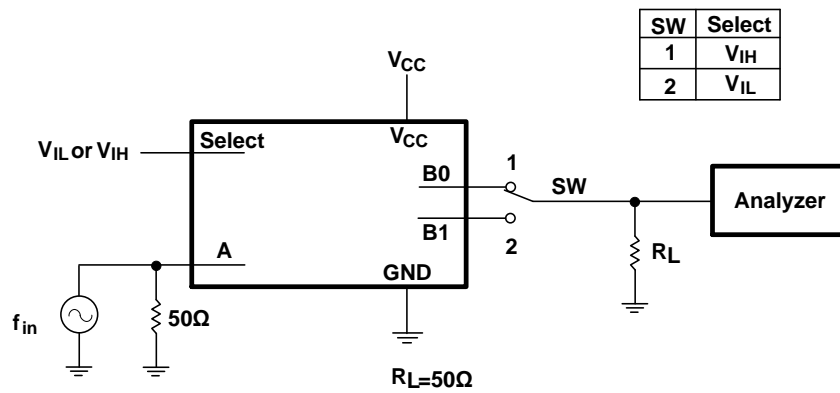

Figure 7 OFF Isolation

Parameter Measurement Information (cont.)

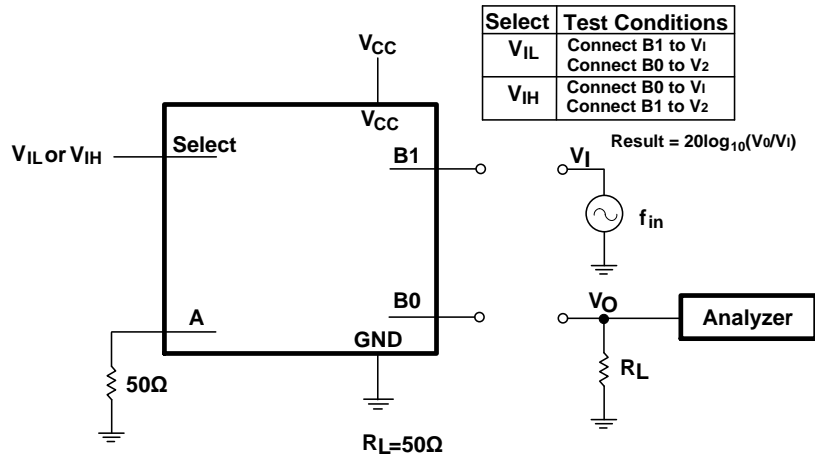
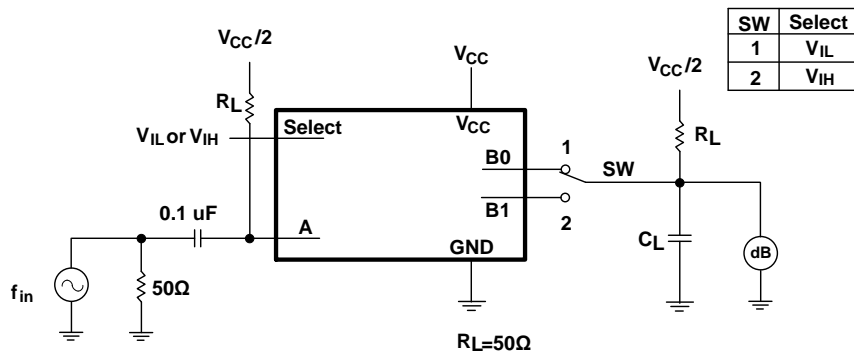

Figure 8 Cross Talk



Adjust fin voltage to obtain 0 dBm level at input.
Adjust fin frequency until dB meter reads -3 dB.

Figure 9 Bandwidth

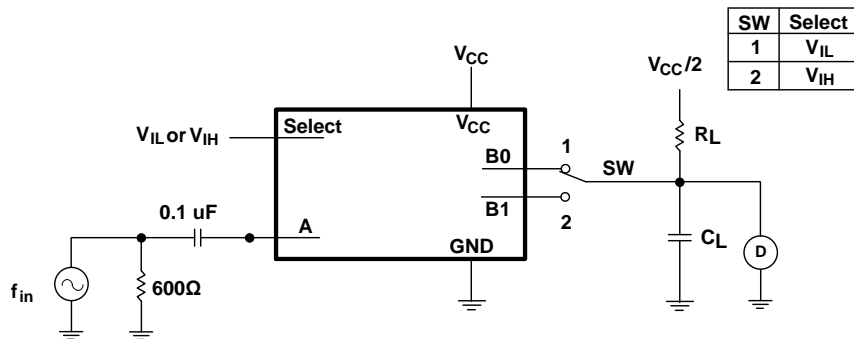

Figure 10 THD

Typical Performance Characteristics

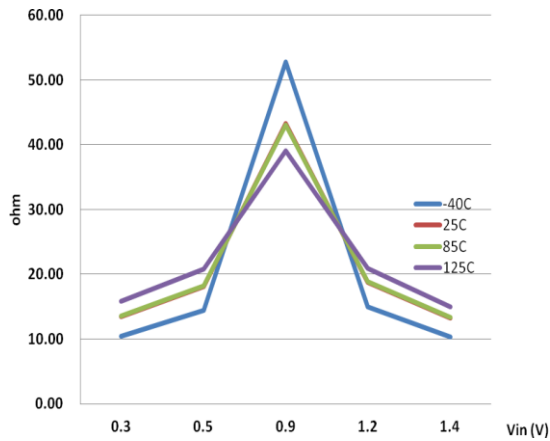

Figure 11 ON state Resistance Vcc = 1.65 V; IBn = 4ma

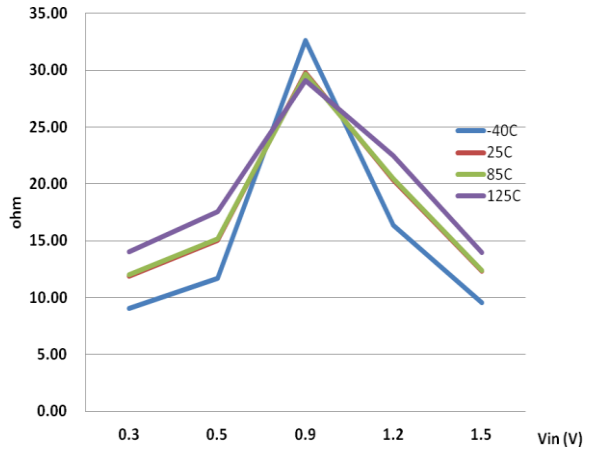

Figure 12 ON state Resistance Vcc = 1.8 V; IBn = 4ma

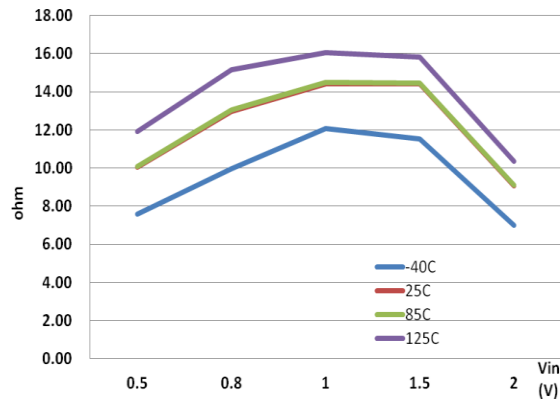

Figure 13 ON state Resistance Vcc = 2.3 V; IBn = 8ma

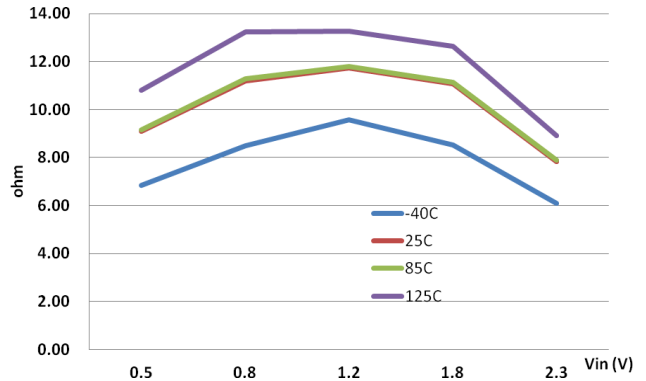

Figure 14 ON state Resistance Vcc = 2.5 V; IBn = 8ma

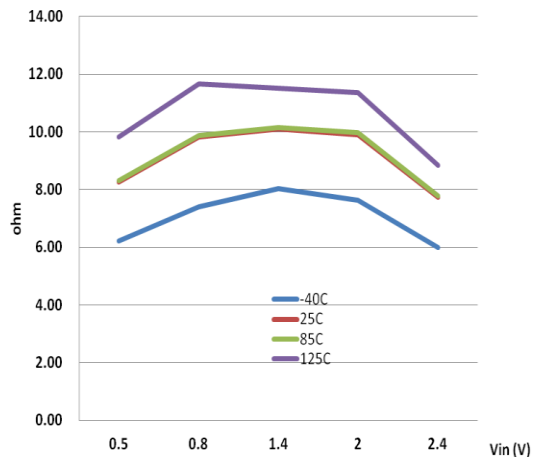

Figure 15 ON state Resistance Vcc = 2.7 V; IBn = 12ma

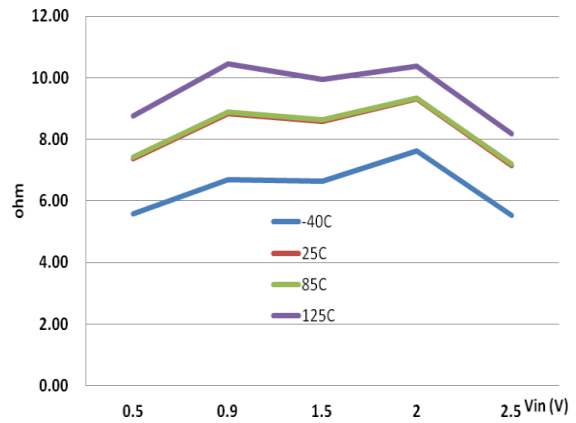

Figure 16 ON state Resistance Vcc = 3 V; IBn = 24ma

Typical Performance Characteristics (continued)

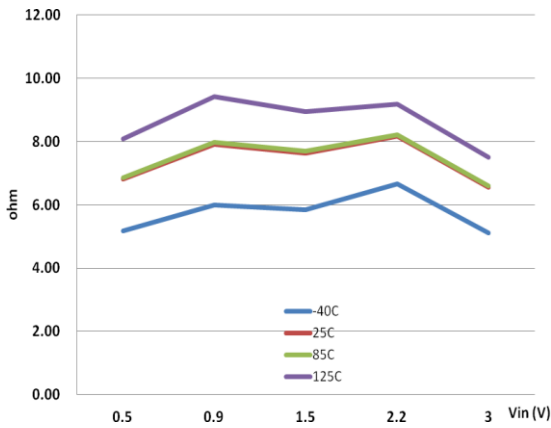

Figure 17 ON state Resistance Vcc = 3.3 V; IBn = 24ma

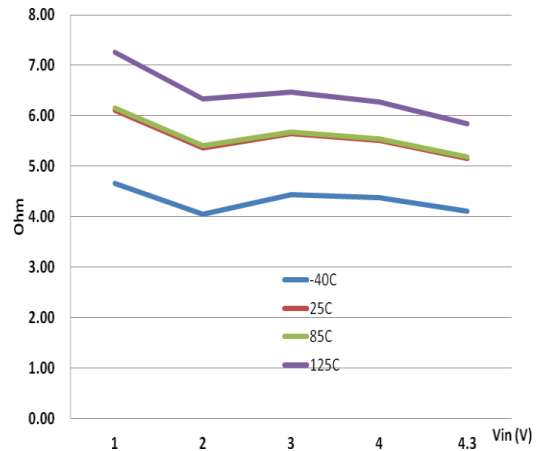

Figure 18 ON state Resistance Vcc = 4.5 V; IBn = 32ma

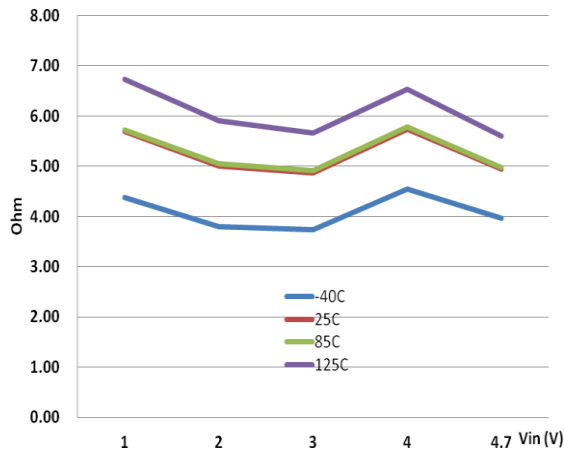

Figure 19 ON state Resistance Vcc = 5.5 V; IBn = 32ma

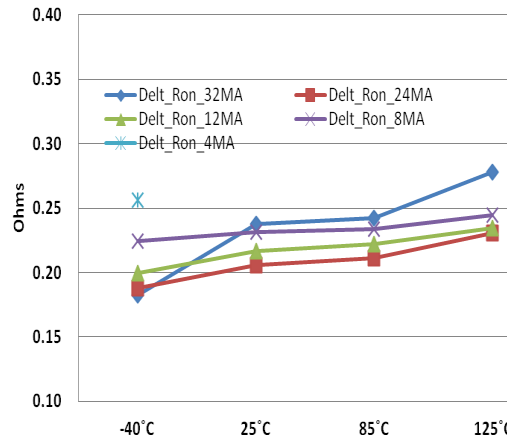

Figure 20 ΔRon-Resistance Match Between Channels

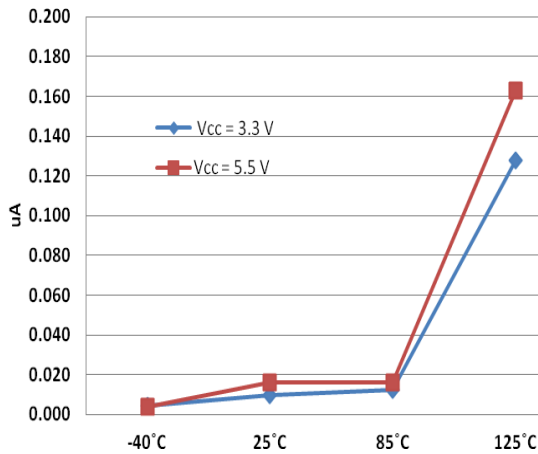

Figure 21 IS(OFF) OFF state leakage VIN = 0 V

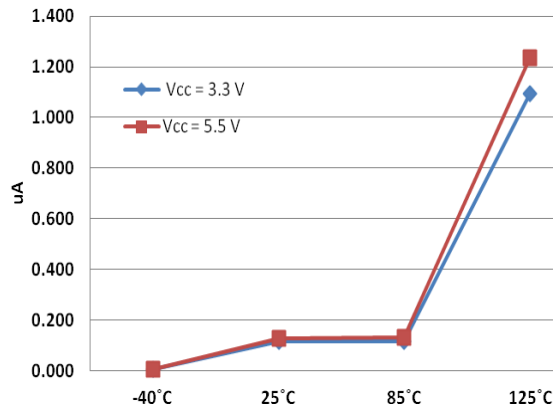

Figure 22 IS(OFF) OFF state leakage VIN = -0.1 V

Typical Performance Characteristics (cont.)

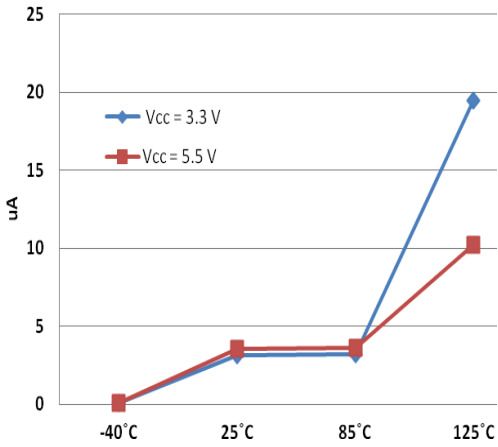

Figure 23 $I_{S(OFF)}$ OFF state leakage $V_{IN} = -0.2 V$

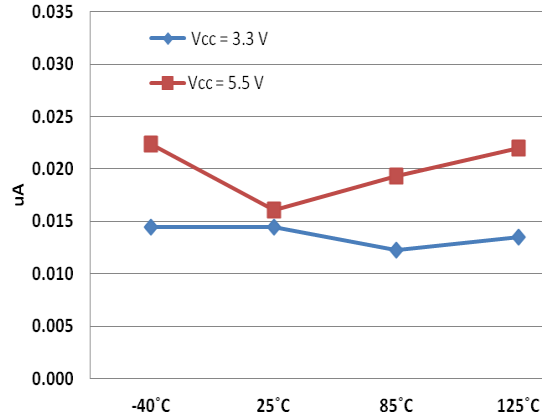

Figure 24 $I_{S(ON)}$ ON state leakage $V_{IN} = 0 V$

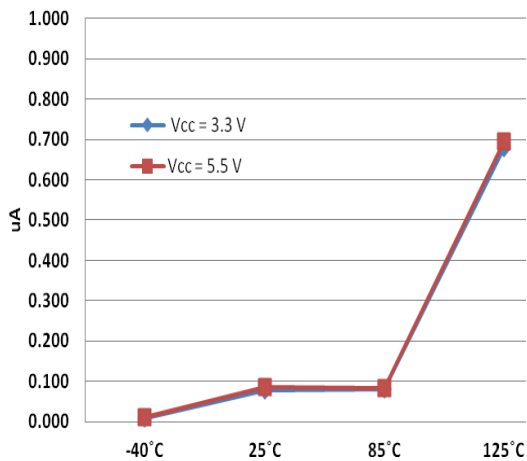

Figure 25 $I_{S(ON)}$ ON state leakage $V_{IN} = -0.1 V$

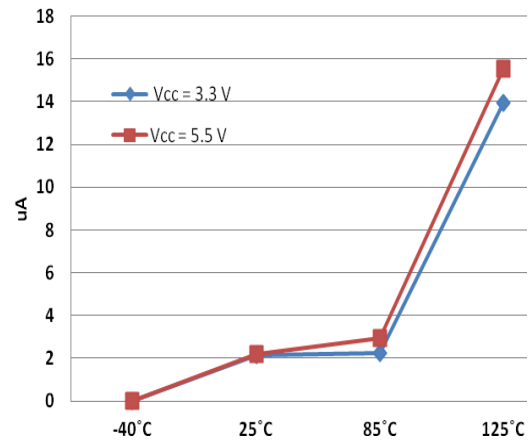

Figure 26 $I_{S(ON)}$ ON state leakage $V_{IN} = -0.2 V$

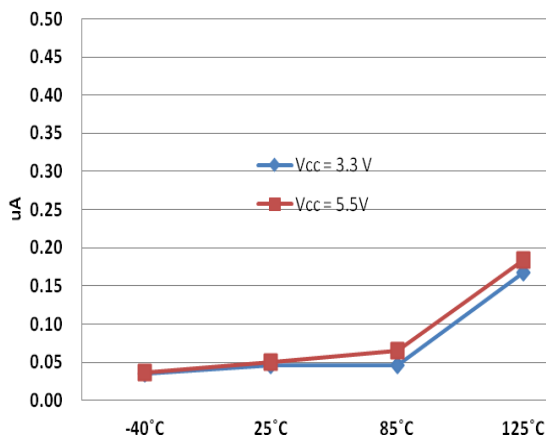

Figure 27 I_{CC} versus Temperature

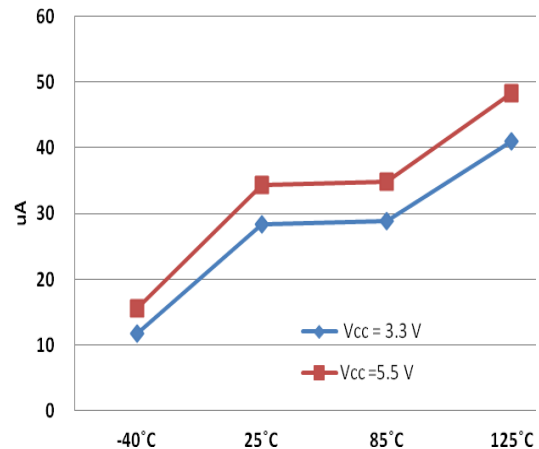

Figure 28 ΔI_{CC} versus Temperature

Typical Performance Characteristics (cont.)

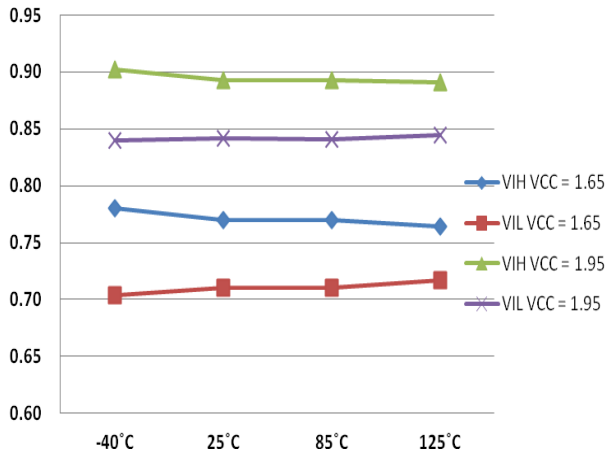

Figure 29 V_{IH} , V_{IL} , Hysteresis $V_{CC} = 1.65\text{ V}$ and $V_{CC} = 1.95\text{ V}$

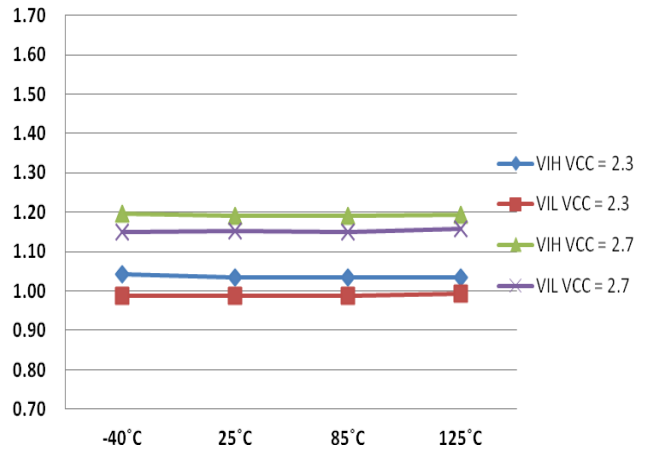

Figure 30 V_{IH} , V_{IL} , Hysteresis $V_{CC} = 2.3\text{ V}$ and $V_{CC} = 2.7\text{ V}$

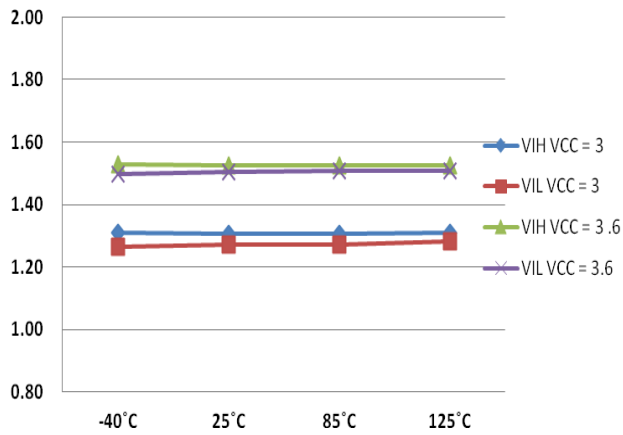

Figure 31 V_{IH} , V_{IL} , Hysteresis $V_{CC} = 3\text{ V}$ and $V_{CC} = 3.3\text{ V}$

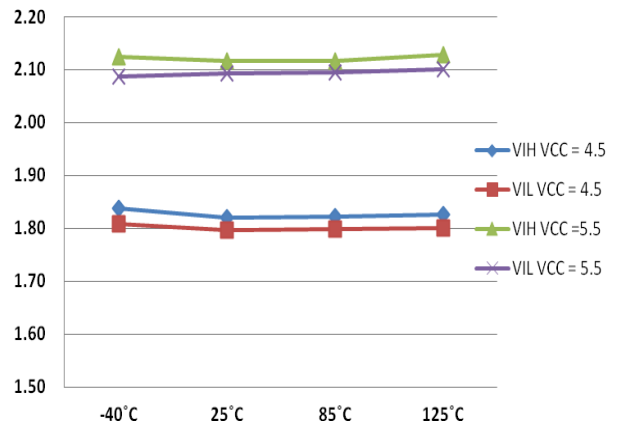
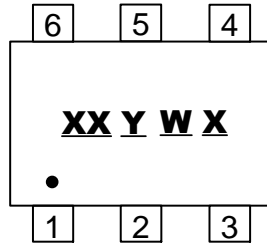

Figure 32 V_{IH} , V_{IL} , Hysteresis $V_{CC} = 4.5\text{ V}$ and $V_{CC} = 5.5\text{ V}$

Marking Information

(1) SOT363



XX : Identification code
 Y : Year 0~9
 W : Week : A~Z : 1~26 week;
 a~z : 27~52 week; z represents 52 and 53 week
 X : A~Z : Internal Code

Part Number	Package	Identification Code
74LVC1G3157DW	SOT363	J7

(2) X2-DFN1410-6

(Top View)

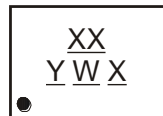

XX : Identification Code
 Y : Year 0~9
 W : Week : A~Z : 1~26 week;
 a~z : 27~52 week;
 z represents 52 and 53 week
 X : A~Z : Internal Code

Part Number	Package	Identification Code
74LVC1G3157FZ4	X2-DFN1410-6	J7

Package Characteristics (All typical values are at V_{CC} = 3.3V, T_A = +25°C)

Symbol	Parameter	Test Conditions	V _{CC}	Min	Typ.	Max	Unit
θ _{JA}	Thermal Resistance Junction-to-Ambient	SOT363	(Note 20)	-	371	-	°C/W
		X2-DFN1410-6		-	460	-	
θ _{JC}	Thermal Resistance Junction-to-Case	SOT363	(Note 20)	-	143	-	°C/W
		X2-DFN1410-6		-	265	-	

Note: 20. Test condition SOT363, and X2-DFN1410-6: Device mounted on FR-4 substrate PC board, 2oz. copper, with minimum recommended pad layout.

SOT363 Package Outline Dimensions and Suggested Pad Layout

Please see <http://www.diodes.com/package-outlines.html> for the latest version.

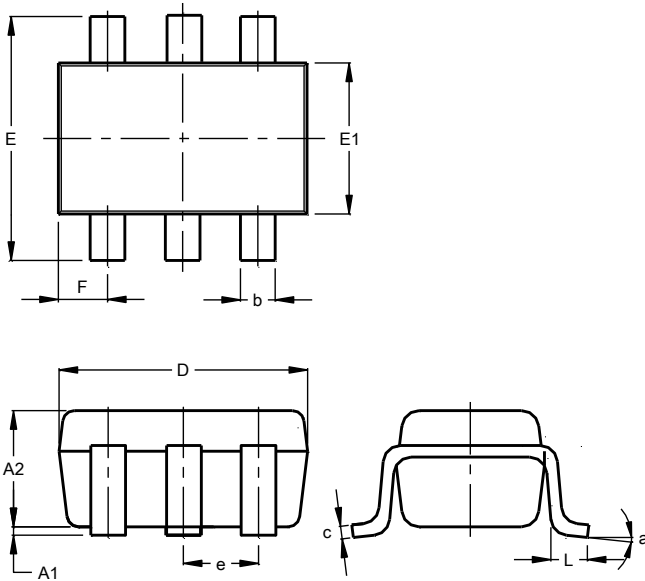

SOT363			
Dim	Min	Max	Typ
A1	0.00	0.10	0.05
A2	0.90	1.00	1.00
b	0.10	0.30	0.25
c	0.10	0.22	0.11
D	1.80	2.20	2.15
E	2.00	2.20	2.10
E1	1.15	1.35	1.30
e	0.650 BSC		
F	0.40	0.45	0.425
L	0.25	0.40	0.30
a	0°	8°	--
All Dimensions in mm			

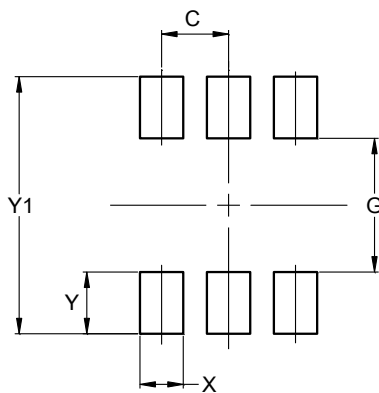

Dimensions	Value (in mm)
C	0.650
G	1.300
X	0.420
Y	0.600
Y1	2.500

IMPORTANT NOTICE

DIODES INCORPORATED MAKES NO WARRANTY OF ANY KIND, EXPRESS OR IMPLIED, WITH REGARDS TO THIS DOCUMENT, INCLUDING, BUT NOT LIMITED TO, THE IMPLIED WARRANTIES OF MERCHANTABILITY AND FITNESS FOR A PARTICULAR PURPOSE (AND THEIR EQUIVALENTS UNDER THE LAWS OF ANY JURISDICTION).

Diodes Incorporated and its subsidiaries reserve the right to make modifications, enhancements, improvements, corrections or other changes without further notice to this document and any product described herein. Diodes Incorporated does not assume any liability arising out of the application or use of this document or any product described herein; neither does Diodes Incorporated convey any license under its patent or trademark rights, nor the rights of others. Any Customer or user of this document or products described herein in such applications shall assume all risks of such use and will agree to hold Diodes Incorporated and all the companies whose products are represented on Diodes Incorporated website, harmless against all damages.

Diodes Incorporated does not warrant or accept any liability whatsoever in respect of any products purchased through unauthorized sales channel.

Should Customers purchase or use Diodes Incorporated products for any unintended or unauthorized application, Customers shall indemnify and hold Diodes Incorporated and its representatives harmless against all claims, damages, expenses, and attorney fees arising out of, directly or indirectly, any claim of personal injury or death associated with such unintended or unauthorized application.

Products described herein may be covered by one or more United States, international or foreign patents pending. Product names and markings noted herein may also be covered by one or more United States, international or foreign trademarks.

This document is written in English but may be translated into multiple languages for reference. Only the English version of this document is the final and determinative format released by Diodes Incorporated.

LIFE SUPPORT

Diodes Incorporated products are specifically not authorized for use as critical components in life support devices or systems without the express written approval of the Chief Executive Officer of Diodes Incorporated. As used herein:

A. Life support devices or systems are devices or systems which:

1. are intended to implant into the body, or
2. support or sustain life and whose failure to perform when properly used in accordance with instructions for use provided in the labeling can be reasonably expected to result in significant injury to the user.

B. A critical component is any component in a life support device or system whose failure to perform can be reasonably expected to cause the failure of the life support device or to affect its safety or effectiveness.

Customers represent that they have all necessary expertise in the safety and regulatory ramifications of their life support devices or systems, and acknowledge and agree that they are solely responsible for all legal, regulatory and safety-related requirements concerning their products and any use of Diodes Incorporated products in such safety-critical, life support devices or systems, notwithstanding any devices- or systems-related information or support that may be provided by Diodes Incorporated. Further, Customers must fully indemnify Diodes Incorporated and its representatives against any damages arising out of the use of Diodes Incorporated products in such safety-critical, life support devices or systems.

Copyright © 2016, Diodes Incorporated

www.diodes.com



Компания «ЭлектроПласт» предлагает заключение долгосрочных отношений при поставках импортных электронных компонентов на взаимовыгодных условиях!

Наши преимущества:

- Оперативные поставки широкого спектра электронных компонентов отечественного и импортного производства напрямую от производителей и с крупнейших мировых складов;
- Поставка более 17-ти миллионов наименований электронных компонентов;
- Поставка сложных, дефицитных, либо снятых с производства позиций;
- Оперативные сроки поставки под заказ (от 5 рабочих дней);
- Экспресс доставка в любую точку России;
- Техническая поддержка проекта, помощь в подборе аналогов, поставка прототипов;
- Система менеджмента качества сертифицирована по Международному стандарту ISO 9001;
- Лицензия ФСБ на осуществление работ с использованием сведений, составляющих государственную тайну;
- Поставка специализированных компонентов (Xilinx, Altera, Analog Devices, Intersil, Interpoint, Microsemi, Aeroflex, Peregrine, Syfer, Eurofarad, Texas Instrument, Miteq, Cobham, E2V, MA-COM, Hittite, Mini-Circuits, General Dynamics и др.);

Помимо этого, одним из направлений компании «ЭлектроПласт» является направление «Источники питания». Мы предлагаем Вам помощь Конструкторского отдела:

- Подбор оптимального решения, техническое обоснование при выборе компонента;
- Подбор аналогов;
- Консультации по применению компонента;
- Поставка образцов и прототипов;
- Техническая поддержка проекта;
- Защита от снятия компонента с производства.



Как с нами связаться

Телефон: 8 (812) 309 58 32 (многоканальный)

Факс: 8 (812) 320-02-42

Электронная почта: org@eplast1.ru

Адрес: 198099, г. Санкт-Петербург, ул. Калинина, дом 2, корпус 4, литера А.