

THIS DRAWING IS UNPUBLISHED. RELEASED FOR PUBLICATION  
 © COPYRIGHT - By - ALL RIGHTS RESERVED.

LOC		DIST		REVISIONS			
AD	00	P	LTR	DESCRIPTION	DATE	DWN	APVD
		A4		REVISED PER ECO-14-005988	23APR2014	NK	RH

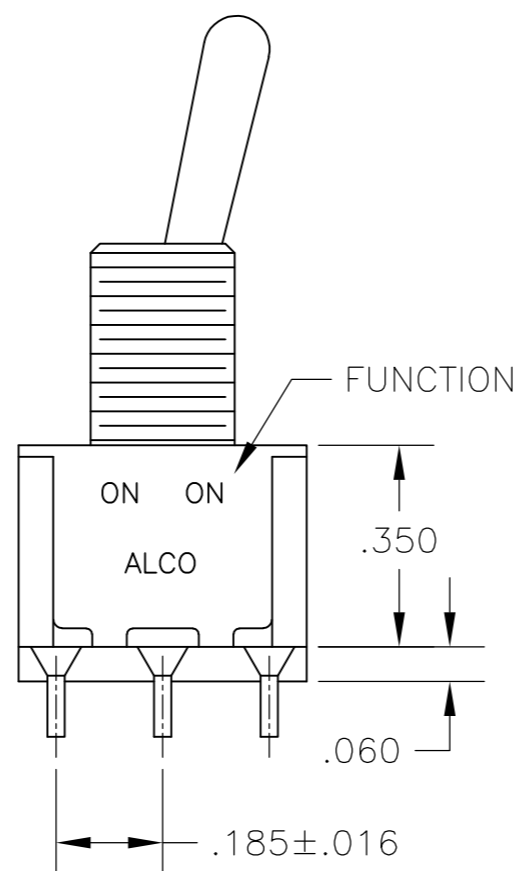
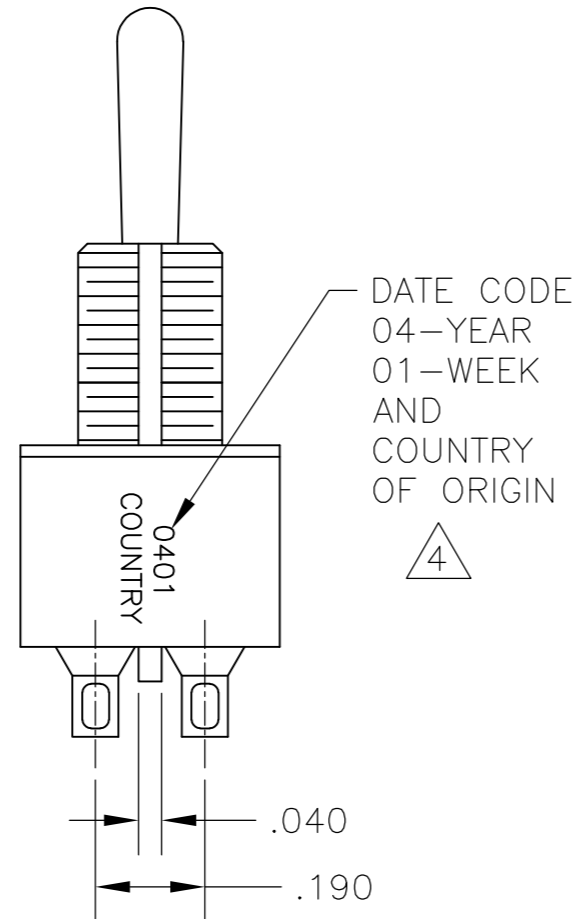
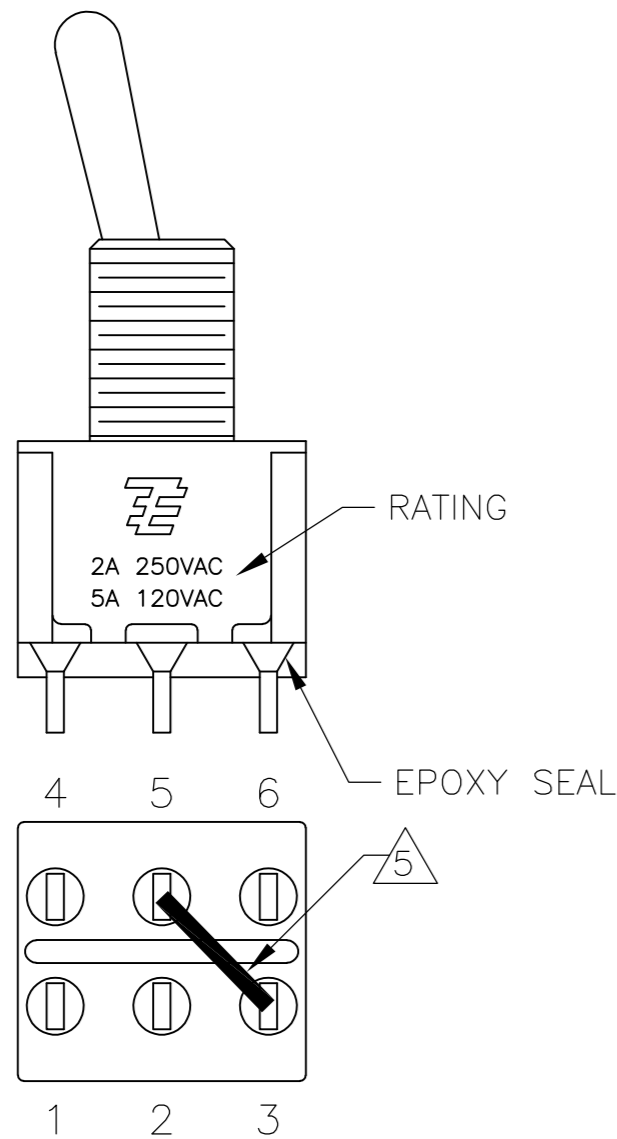
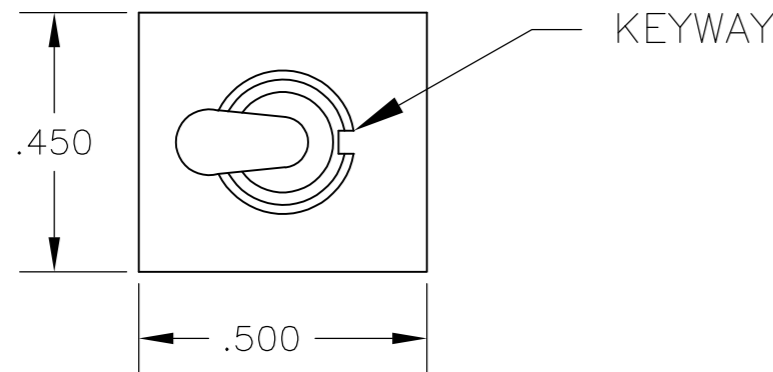

- ALL MATERIALS AND FINISHES SHALL COMPLY WITH EU DIRECTIVE 2002/95/EC OF 27JAN2003 (ROHS).
  - EACH SWITCH WITH THREADED BUSHINGS SUPPLIED WITH THE FOLLWING MOUNTING HARDWARE:  
 (2) HEX NUTS  
 (1) INTERNAL TOOTH LOCKWASHER  
 (1) LOCATING RING.
  - G CONTACT OPTION CAN BE USED FOR SIGNAL OR POWER LEVEL SWITCHING. IF SWITCH IS USED AT LEVELS EXCEEDING .4VA @ 20V AC/DC, SWITCH IS RENDERED FOR POWER SWITCHING ONLY DUE TO ARC REMOVAL OF GOLD PLATING. RATING MARKED ON FRAME IS 2A 250VAC, 5A 120VAC.
- △4 DATE CODE AND COUNTRY OF ORIGIN MAY APPEAR ON EITHER SIDE OF SWITCH.  
 △5 SP3T FUNCTION ACHIEVED WITH FUNCTIONS 11, 13 & 15 BY CUSTOMER APPLIED JUMPER BETWEEN TERMINALS 3 AND 5.  
 △6 LENGTH OF TOGGLE REDUCED BY .020 WITH A, AV2, V30 OR V40 VERTICAL SUPPORT BRACKET.  
 7 ALL LOGO, RATING, DATE CODE, AND FUNCTION MARKINGS TO BE LASER MARKED.

RATING, B CONTACTS	.4VA MAX @20V MAX. AC OR DC
RATING, G CONTACTS—SEE NOTE 3	.4VA MAX @20V MAX. AC OR DC OR 5A @120 VAC OR 28 VDC (RESISTIVE)
	2A @250 VAC (RESISTIVE)
RATING, Q CONTACTS	5A @120 VAC OR 28 VDC (RESISTIVE)
	2A @250 VAC (RESISTIVE)
ELECTRICAL LIFE	6,000 CYCLES AT RATED LOAD
CONTACT RESISTANCE	10 MILLIOHMS MAX INITIAL @ 2-4VDC, 100ma
INSULATION RESISTANCE	1,000 MEGOHMS MIN
DIELECTRIC WITHSTANDING VOLTAGE	1,000 V RMS AT SEA LEVEL
OPERATING TEMPRATURE	-30C TO 85C

FUNCTION	1 2 3 4 5 6	1 2 3 4 5 6	1 2 3 4 5 6
03	ON	OFF	ON
05	(ON)	OFF	(ON)
07	ON	OFF	(ON)
TERMINALS CONNECTED	2-3, 5-6	---	1-2, 4-5
11	ON	ON	ON
13	ON	ON	(ON)
15	(ON)	ON	(ON)
TERMINALS CONNECTED	2-3, 5-6	2-3, 4-5	1-2, 4-5
SP3T SCHEMATIC (11, 13 & 15 ONLY) SEE NOTE 5	6 • 3 5 • 2 4 • 1	6 • 3 5 • 2 4 • 1	6 • 3 5 • 2 4 • 1
	IN 2, OUT 6	IN 2, OUT 4	IN 2, OUT 1
None: No mechanical position Off: Mechanical position with no electrical connection (On): Momentary action			

MODEL	FUNCTION	TOGGLE	BUSHING	TERMINAL	CONTACT	RoHS
A2	03	K	CW	A	B	04
	05	K1	D	AV2	G	
	07	L	D9	C	Q	
	11	L1	H	V30		
	13	L2	Y	V40		
	15	M	Y9	V70		
		P3		W		
		S		W4		
		T		Z		
		T1		Z3		

EXAMPLE: A207SYZQ04

THIS DRAWING IS A CONTROLLED DOCUMENT.		DWN M. ZITTO	18MAY05	TE Connectivity	
DIMENSIONS: INCHES		CHK M. ZITTO	-		
TOLERANCES UNLESS OTHERWISE SPECIFIED:		APVD M. ZITTO	-	NAME	
0 PLC ± -		PRODUCT SPEC	-	GEMINI A SERIES TOGGLE SWITCH, DOUBLE POLE, 3 POSITION FUNCTIONS (03, 05, 07, 11, 13 & 15)	
1 PLC ± -		APPLICATION SPEC	-	SIZE	RESTRICTED TO
2 PLC ± -			-	A2	-
3 PLC ± .010			-	CAGE CODE	DRAWING NO
4 PLC ± -			-	00779	C=1825139
ANGLES ± 2°			-	SCALE	SHEET
FINISH			-	3:1	1 of 4
MATERIAL			-	CUSTOMER DRAWING	REV
			-		A4

THIS DRAWING IS UNPUBLISHED. RELEASED FOR PUBLICATION  
 © COPYRIGHT - By - ALL RIGHTS RESERVED.

# TOGGLES

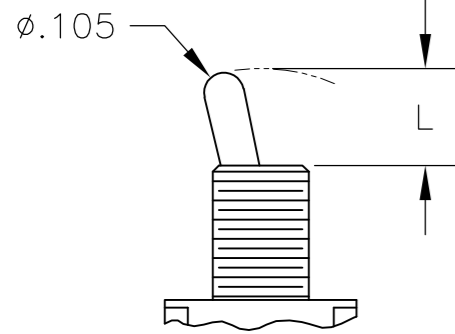

**M** SHORT

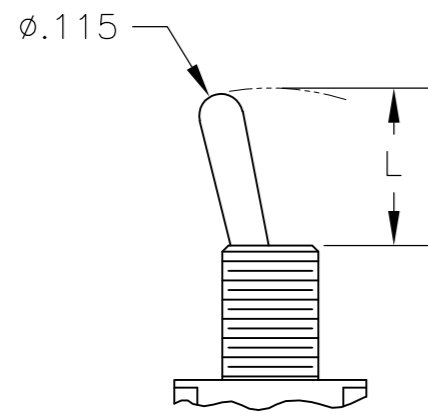

**S** STANDARD

DIM L	BUSHING TYPE	DIM L	BUSHING TYPE
.200	Y, H	.410	Y, H
.270	D, D9	.480	D, D9

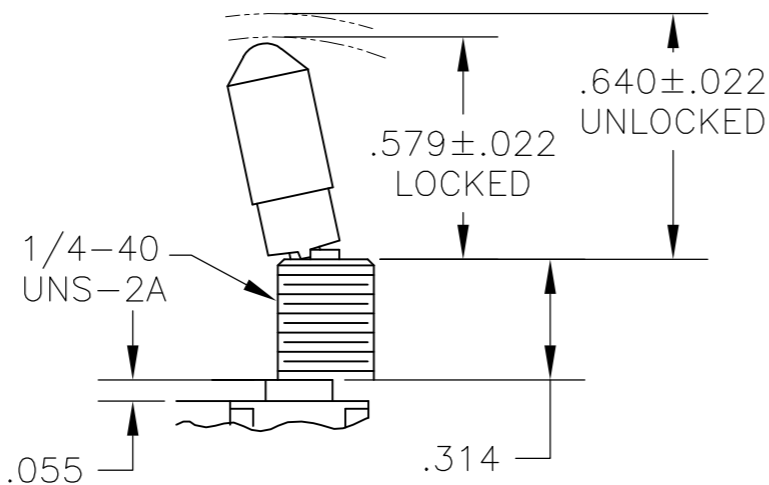

**K** NO BUSHING OPTION NEEDED

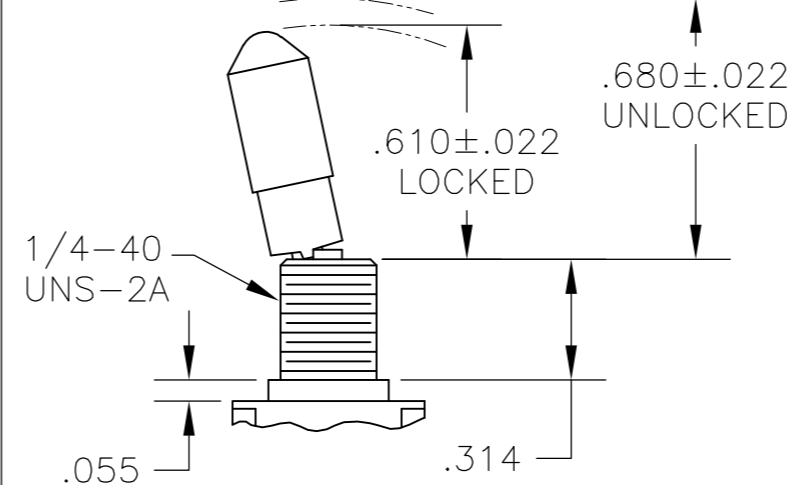

**K1** NO BUSHING OPTION NEEDED

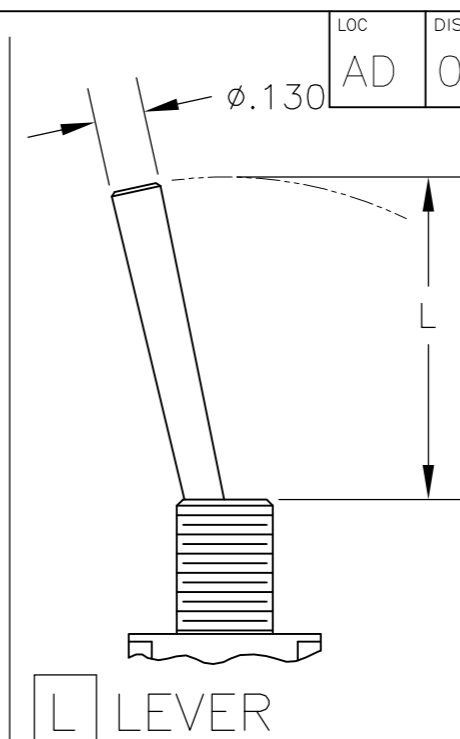

**L** LEVER

DIM L	BUSHING TYPE
.840	Y, H
.910	D, D9

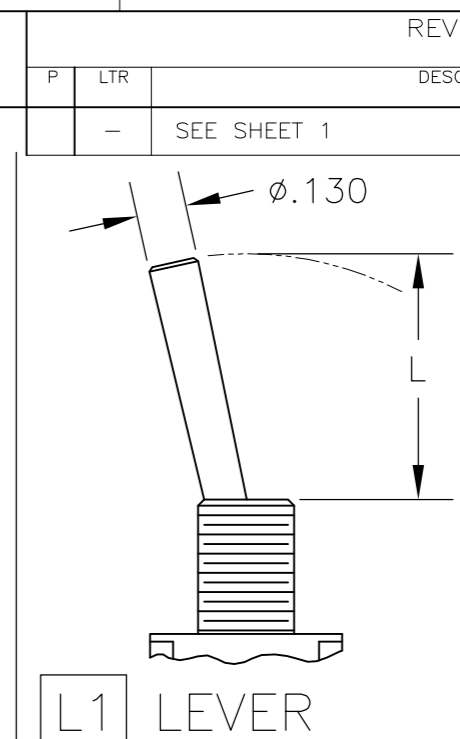

**L1** LEVER

DIM L	BUSHING TYPE
.640	Y, H
.710	D, D9

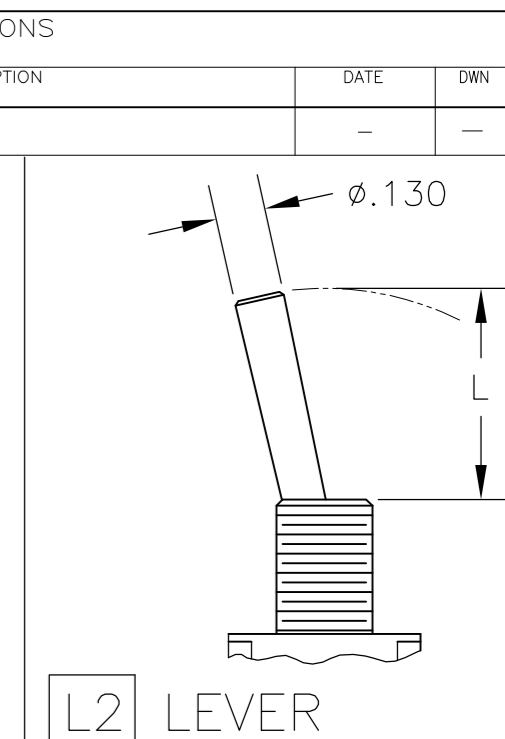

**L2** LEVER

DIM L	BUSHING TYPE
.550	Y, H
.620	D, D9

REVISIONS				DATE	DWN	APVD
P	LTR	DESCRIPTION				
-	-	SEE SHEET 1	-	-	-	-

Loc AD DIST 00

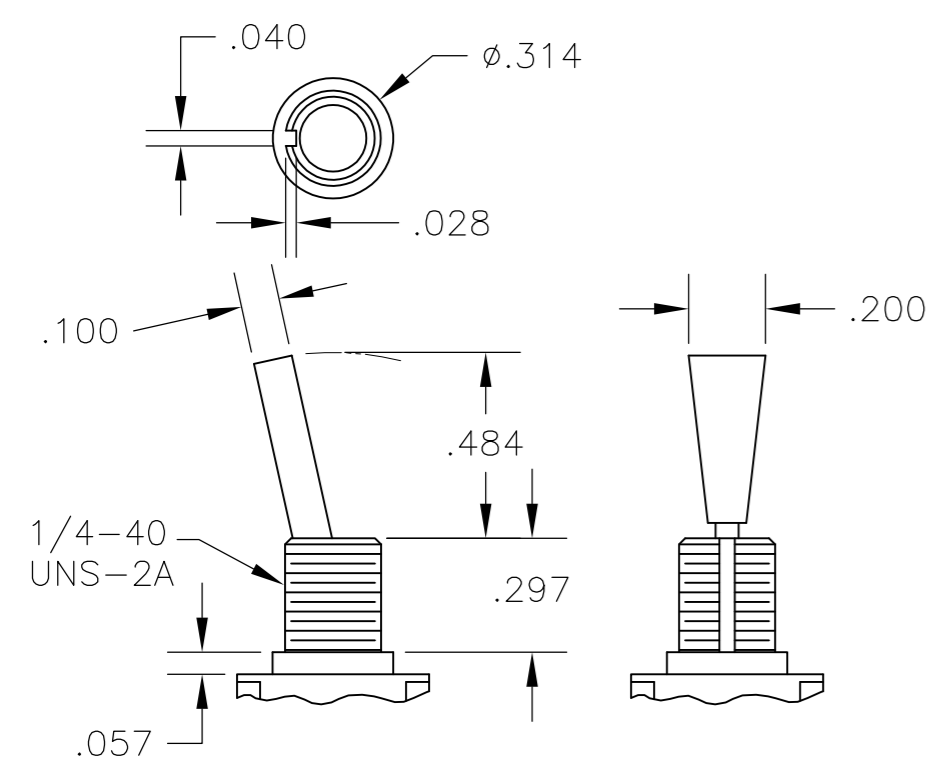

**P3** NO BUSHING OPTION NEEDED

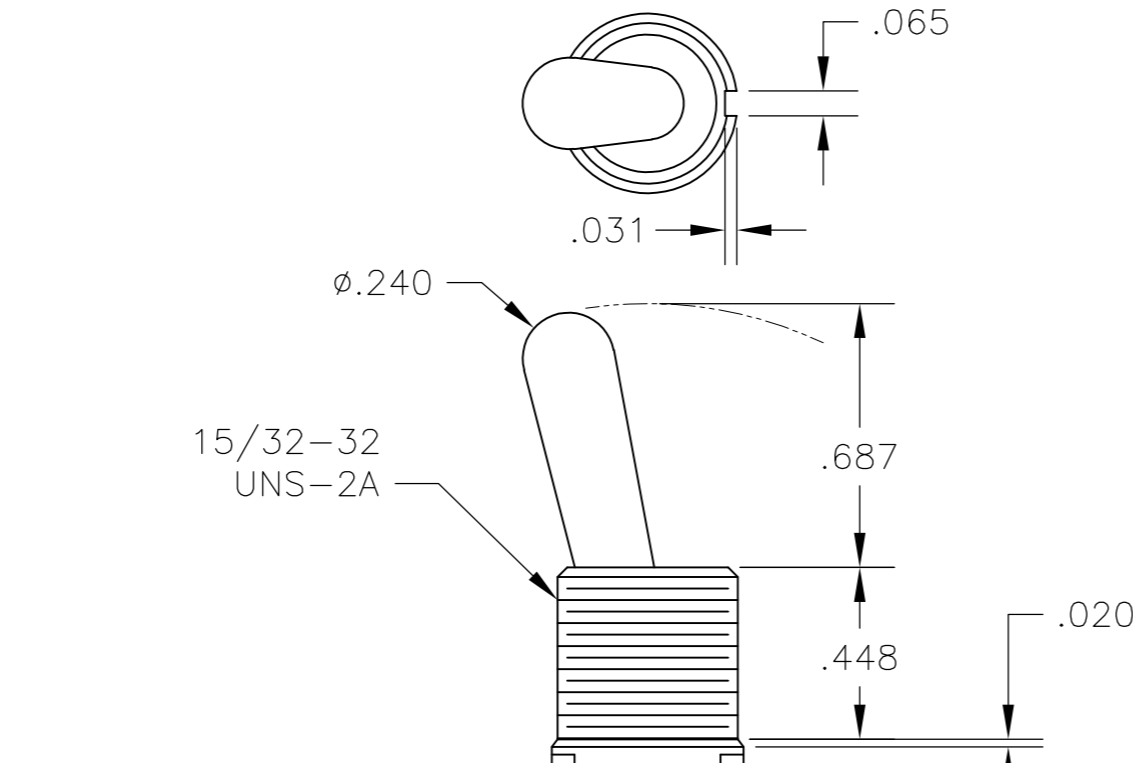

**T** NO BUSHING OPTION NEEDED

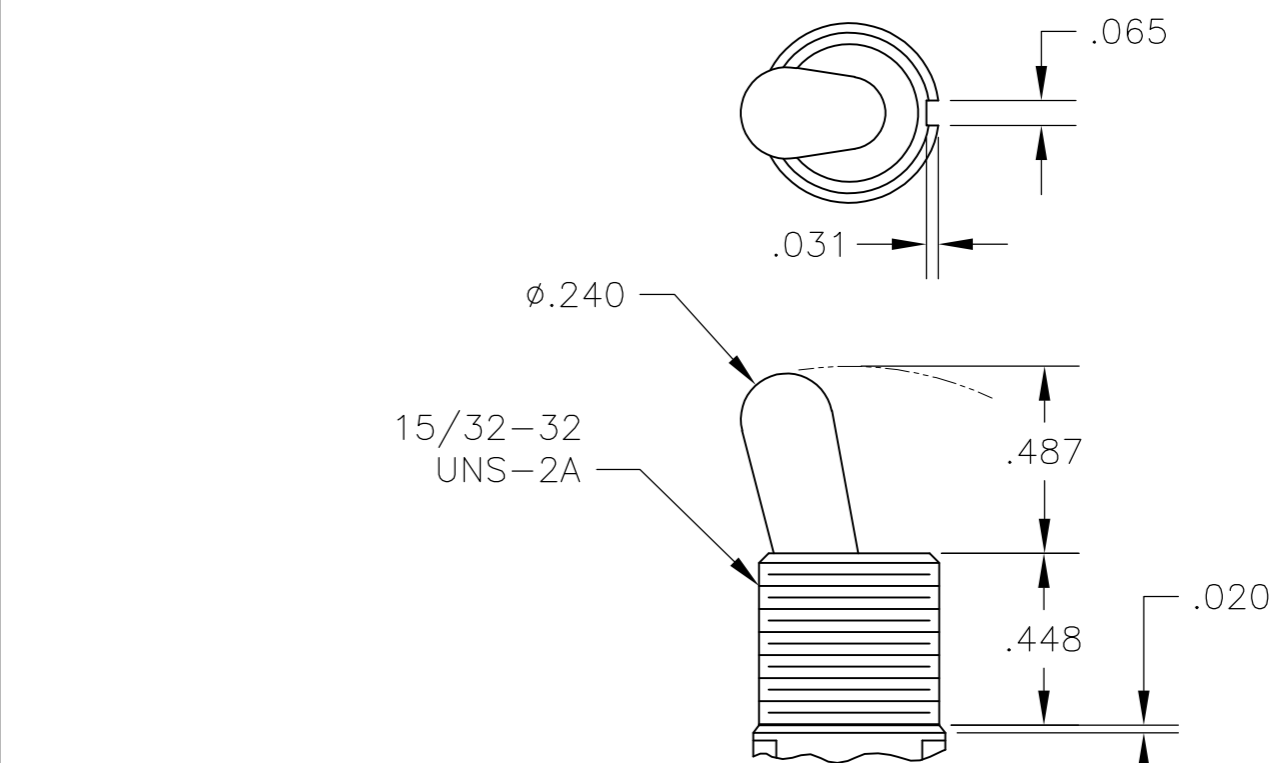

**T1** NO BUSHING OPTION NEEDED

# BUSHINGS

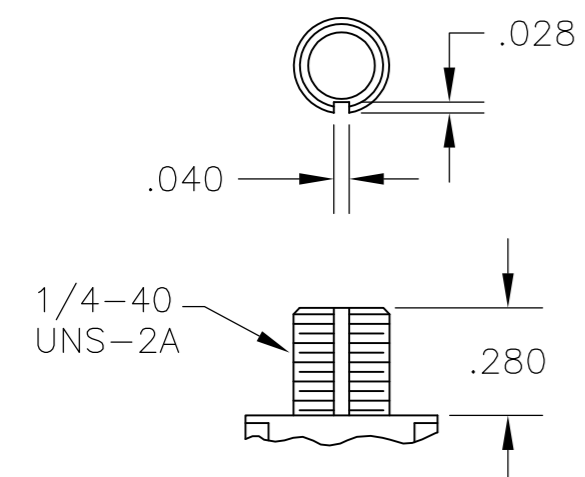

**D** THREADED  
**D9** UNTHREADED

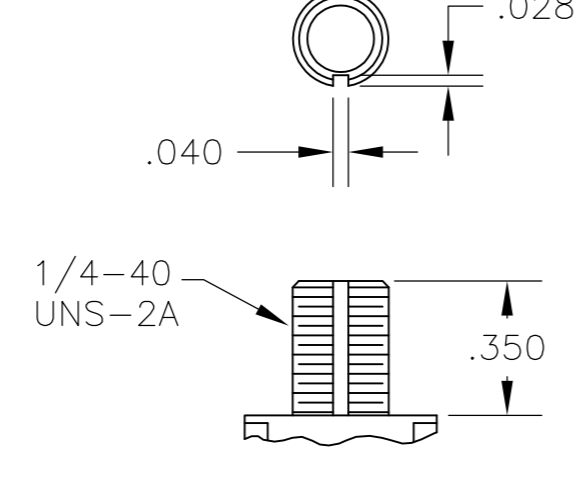

**Y** THREADED  
**Y9** UNTHREADED

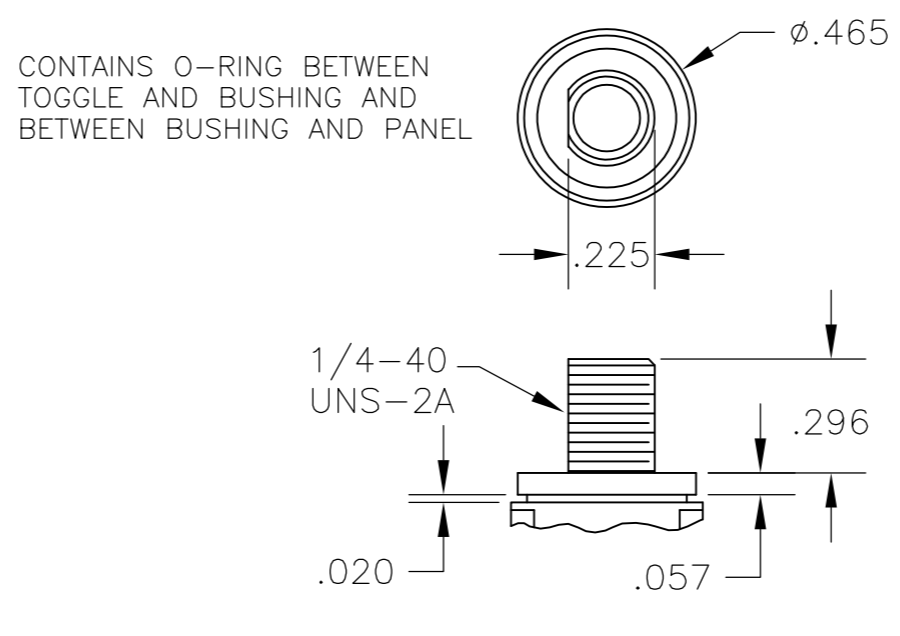

**CW** THREADED SPLASHPROOF

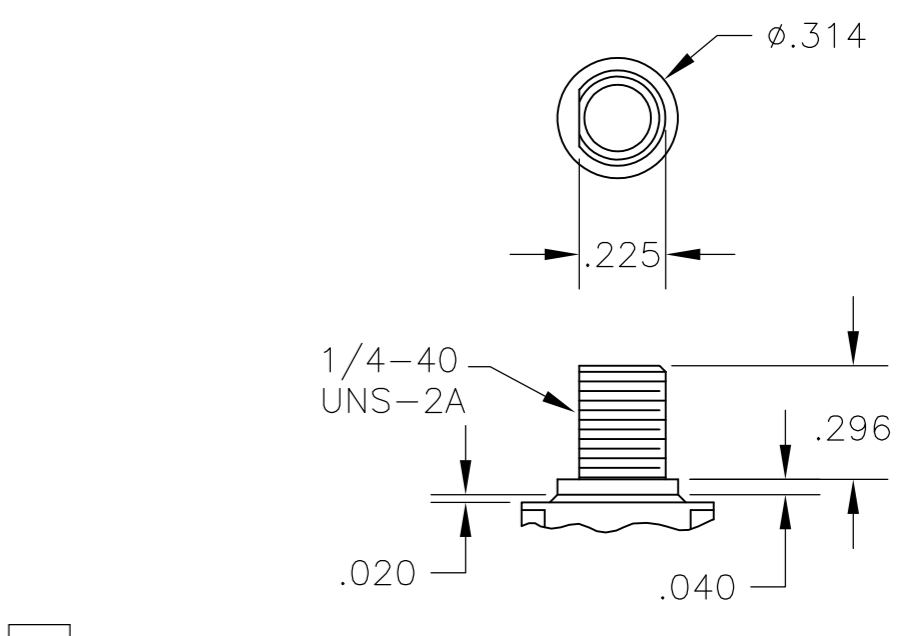

**H** HIGH TORQUE

CONTAINS O-RING BETWEEN TOGGLE AND BUSHING AND BETWEEN BUSHING AND PANEL

THIS DRAWING IS A CONTROLLED DOCUMENT.		DWN M. ZITTO 14APR05		
DIMENSIONS: INCHES		CHK M. ZITTO		
TOLERANCES UNLESS OTHERWISE SPECIFIED:		APVD M. ZITTO	NAME	
0 PLC ± -	1 PLC ± -	PRODUCT SPEC	GEMINI A SERIES TOGGLE SWITCH, DOUBLE POLE, 3 POSITION FUNCTIONS (03, 05, 07, 11, 13 & 15)	
2 PLC ± -	3 PLC ± .010	APPLICATION SPEC	SIZE	CAGE CODE
4 PLC ± -	ANGLES ± 2°	WEIGHT	A2	00779
MATERIAL	FINISH	CUSTOMER DRAWING	DRAWING NO	RESTRICTED TO
			C=1825139	
		SCALE 2:1	SHEET 2 of 4	REV A4

THIS DRAWING IS UNPUBLISHED. RELEASED FOR PUBLICATION  
 © COPYRIGHT - By - ALL RIGHTS RESERVED.

LOC		DIST		REVISIONS				
P	LTR	DESCRIPTION	DATE	DWN	APVD			
AD	00	SEE SHEET 1	-	-	-			

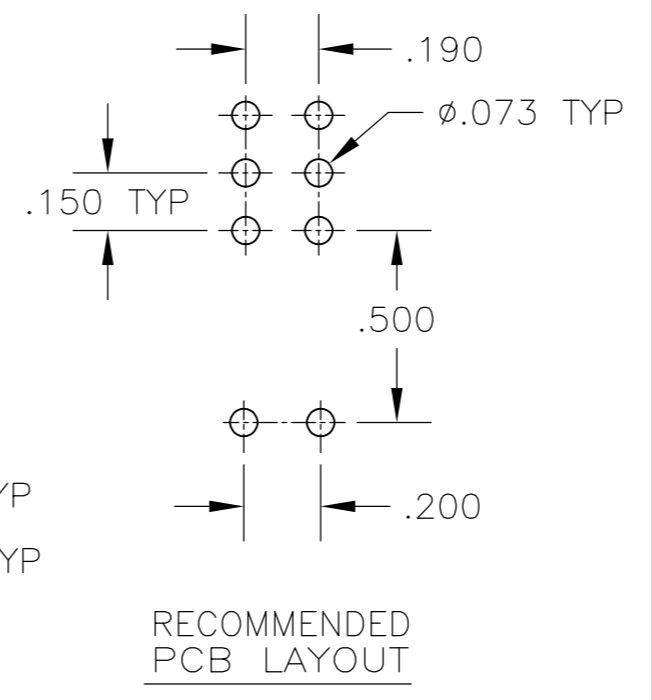
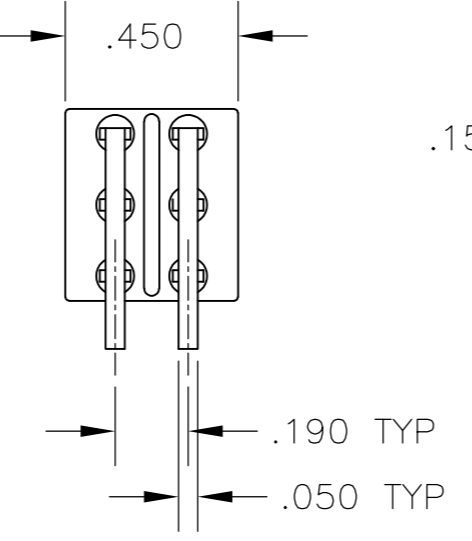
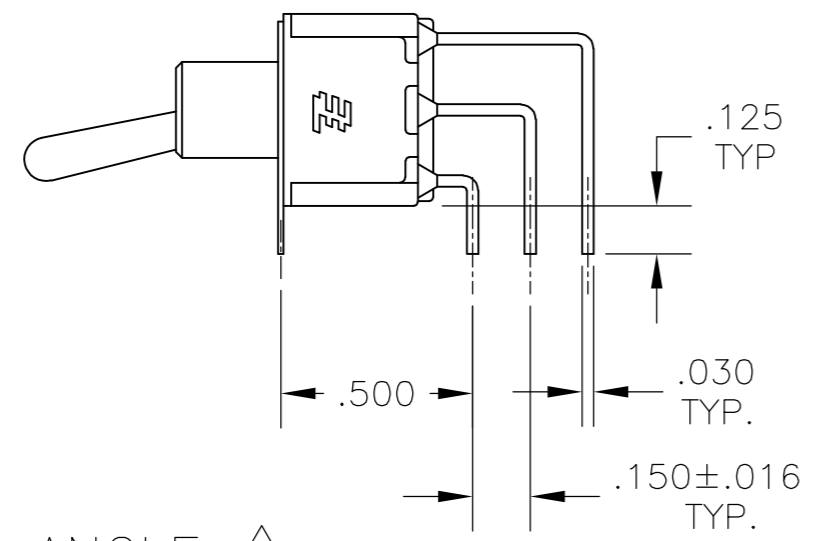
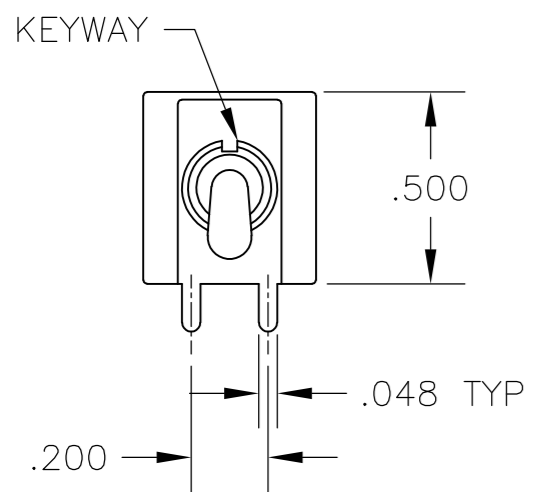

AV2 VERTICAL RIGHT ANGLE

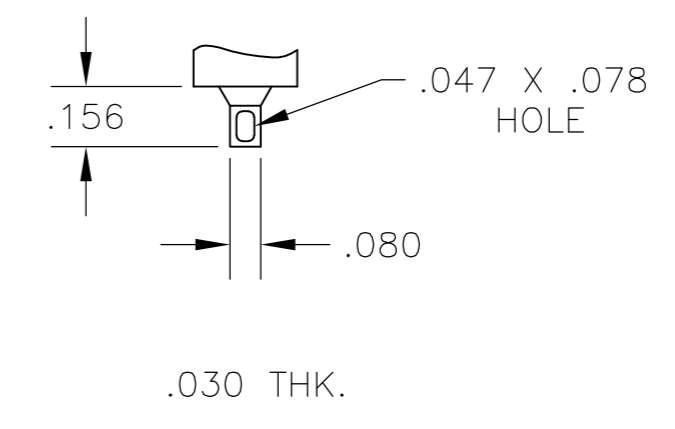

Z WIRE LUG

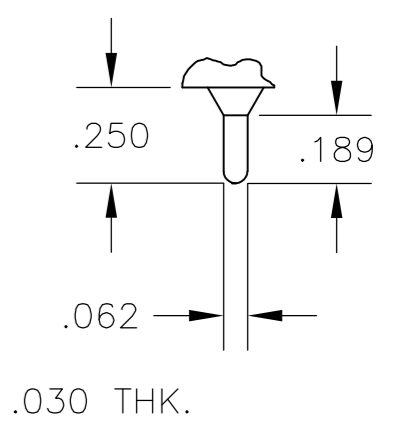

Z3 QUICK CONNECT

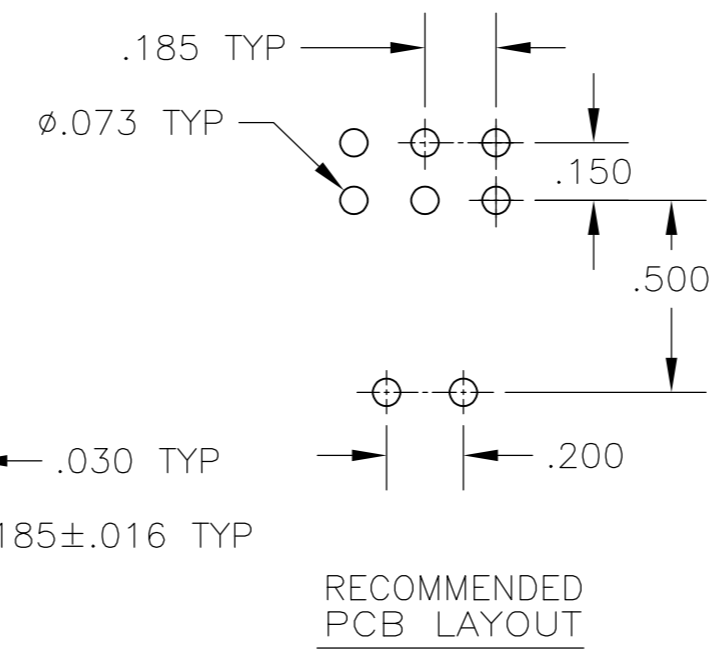
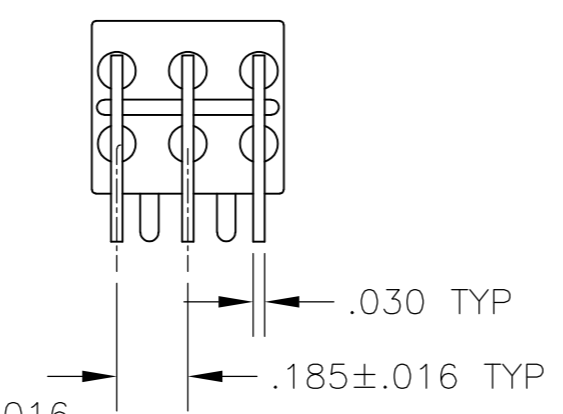
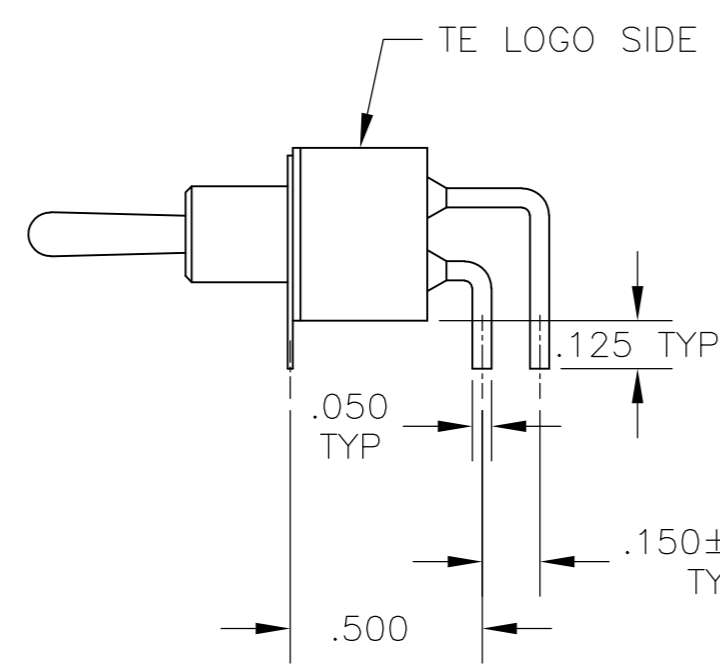
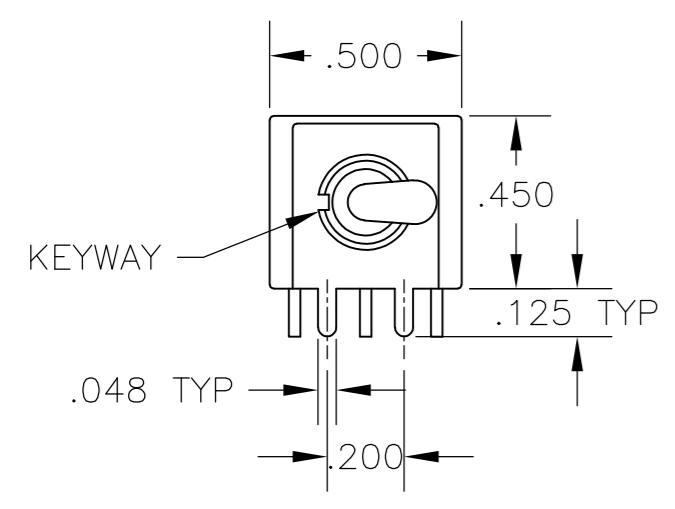

A RIGHT ANGLE

OPTION	DIM A
W	.736
W4	1.062

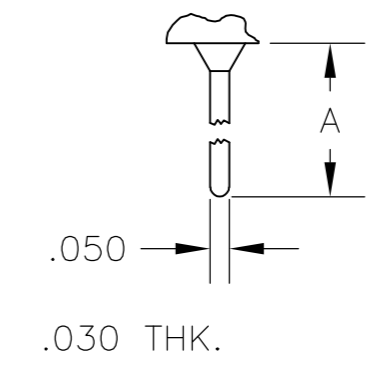

W W4 WIRE WRAP

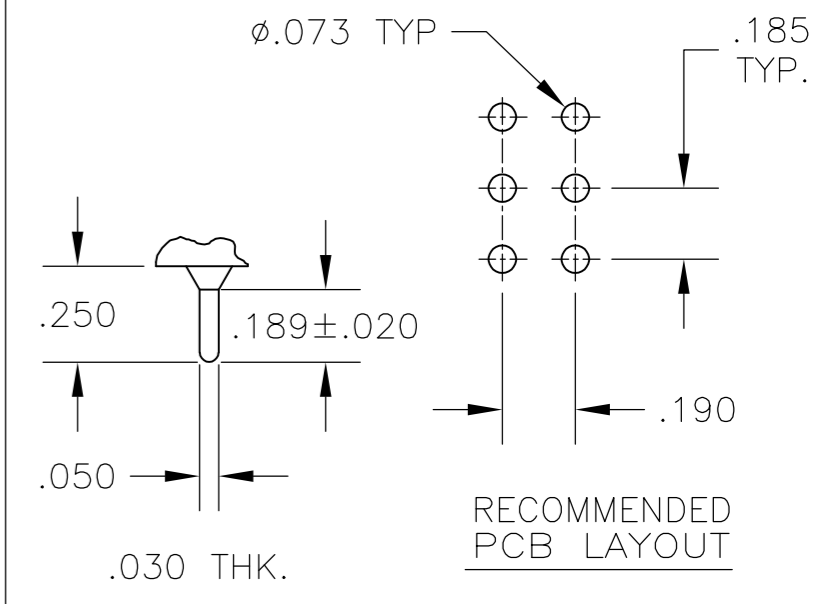

C PRINTED CIRCUIT

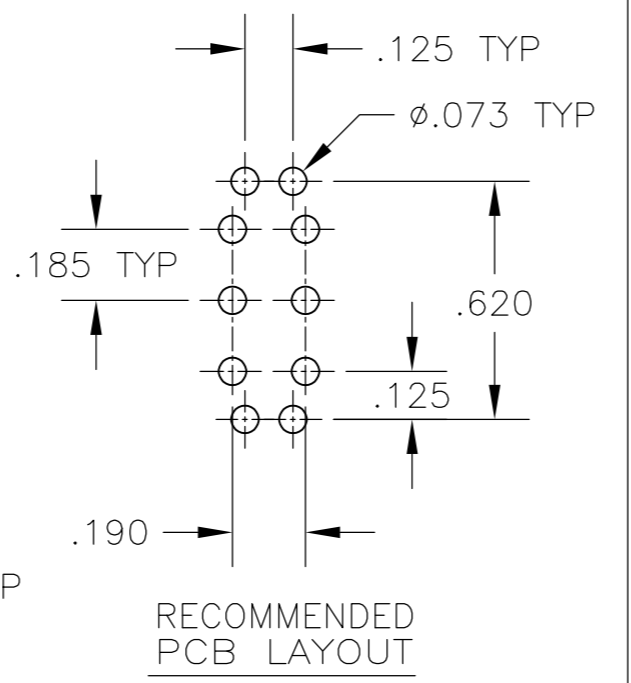
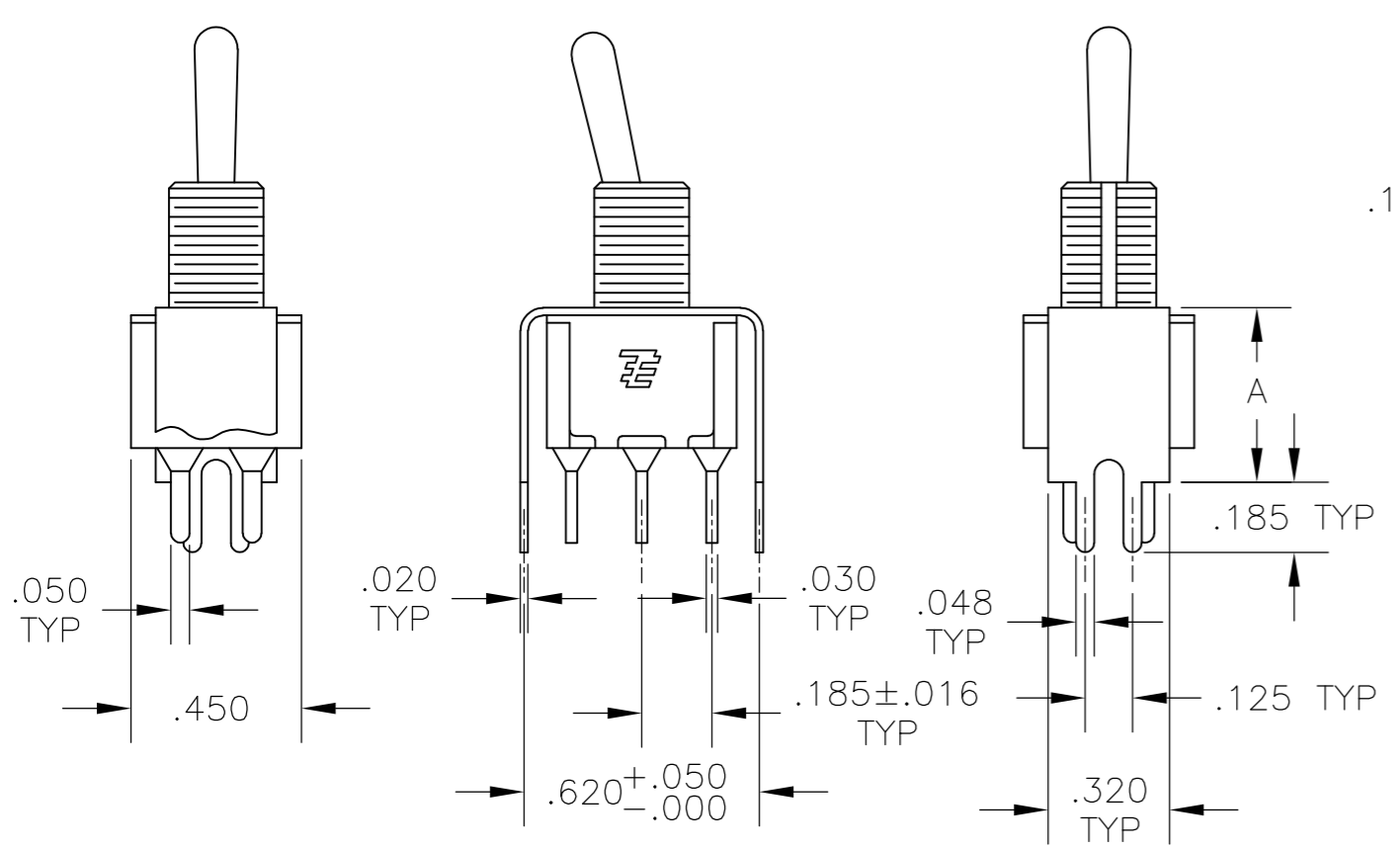

OPTION	DIM A
V30	.460
V40	.630

V30 V40 VERTICAL SUPPORT BRACKET

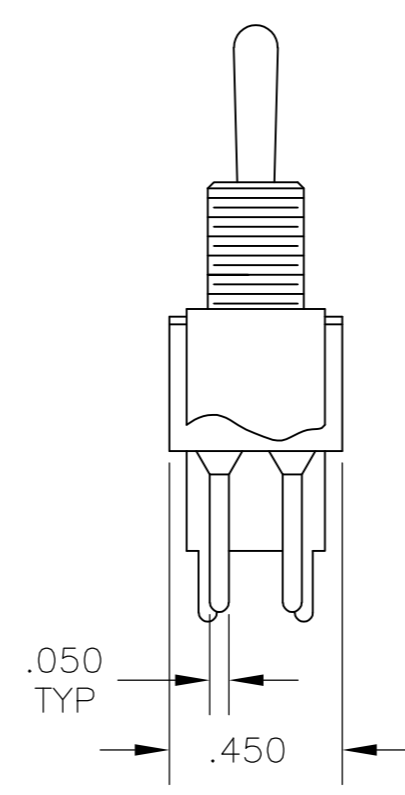

V70 VERTICAL SUPPORT BRACKET

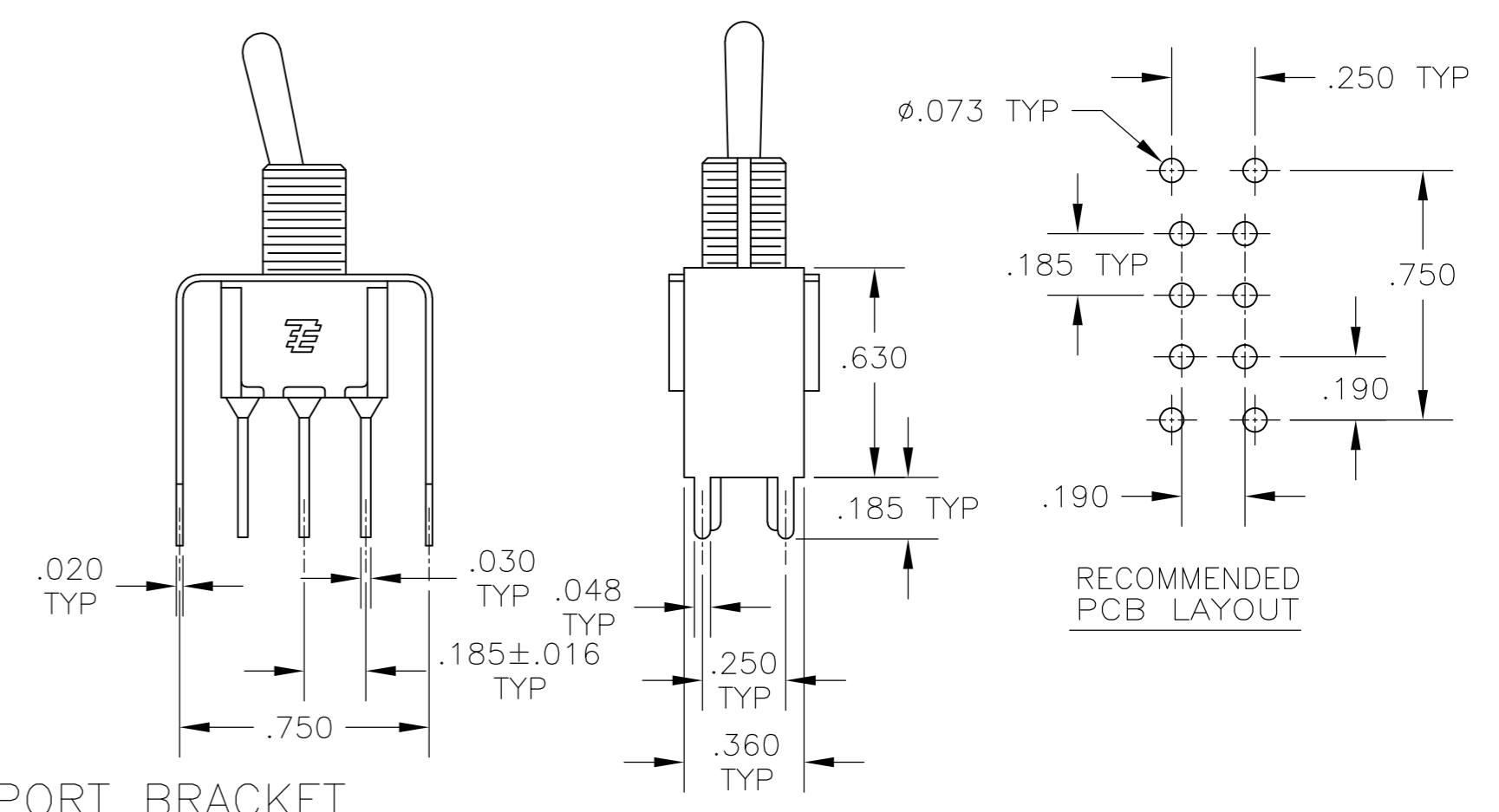

RECOMMENDED PCB LAYOUT

THIS DRAWING IS A CONTROLLED DOCUMENT.

DIMENSIONS: INCHES	TOLERANCES UNLESS OTHERWISE SPECIFIED:	DWN M. ZITTO	14APR05	TE Connectivity
	0 PLC ± -	CHK M. ZITTO	-	
	1 PLC ± -	APVD M. ZITTO	-	
	2 PLC ± -	PRODUCT SPEC	-	
	3 PLC ± .010	APPLICATION SPEC	-	
MATERIAL	FINISH	WEIGHT	-	NAME GEMINI A SERIES TOGGLE SWITCH, DOUBLE POLE, 3 POSITION FUNCTIONS (03, 05, 07, 11, 13 & 15) SIZE A2 CAGE CODE 00779 DRAWING NO. 1825139 RESTRICTED TO CUSTOMER DRAWING SCALE 2:1 SHEET 3 OF 4 REV A4

THIS DRAWING IS UNPUBLISHED. RELEASED FOR PUBLICATION  
 © COPYRIGHT - By - ALL RIGHTS RESERVED.

LOC	DIST	REVISIONS					
AD	00	P	LTR	DESCRIPTION	DATE	DWN	APVD
		-	-	SEE SHEET 1	-	-	-

Alco P/N	P/N
A203KZQ04	1825139-1
A203MD9AB04	1825139-2
A203P3AV2Q04	1825139-3
A203P3ZQ04	1825139-4
A203SD9AV2B04	1825139-5
A203SD9AV2Q04	1825139-6
A203SDZQ04	1825139-7
A203SYCB04	1825139-8
A203SYCQ04	1825139-9
A203SYZQ04	1-1825139-0
A203T1ZQ04	1-1825139-1
A203TZQ04	1-1825139-2
A205KZB04	1-1825139-3
A205P3ZQ04	1-1825139-4
A205SD9AB04	1-1825139-5
A205SYCB04	1-1825139-6
A205SYCQ04	1-1825139-7
A205SYZQ04	1-1825139-8
A205T1ZQ04	1-1825139-9
A205TZQ04	2-1825139-0
A207P3ZQ04	2-1825139-1
A207SYCB04	2-1825139-2
A207SYCQ04	2-1825139-3
A207SYZQ04	2-1825139-4
A207T1ZQ04	2-1825139-5
A207TZQ04	2-1825139-6
A211KZB04	2-1825139-7
A211MD9AQ04	2-1825139-8
A211MYCQ04	2-1825139-9
A211P3CQ04	3-1825139-0
A211P3V40G04	3-1825139-1
A211P3ZQ04	3-1825139-2
A211SCWCQ004	3-1825139-3
A211SDZQ04	3-1825139-4
A211SHZQ04	3-1825139-5
A211SY9AQ04	3-1825139-6
A211SYCQ04	3-1825139-7
A211SYZB04	3-1825139-8
A211SYZQ04	3-1825139-9
A211T1ZQ04	4-1825139-0
not assigned	4-1825139-1
A213SYZQ04	4-1825139-2
A215SD9V30B04	4-1825139-3
A215SY9AQ04	4-1825139-4
A215SYZQ04	4-1825139-5

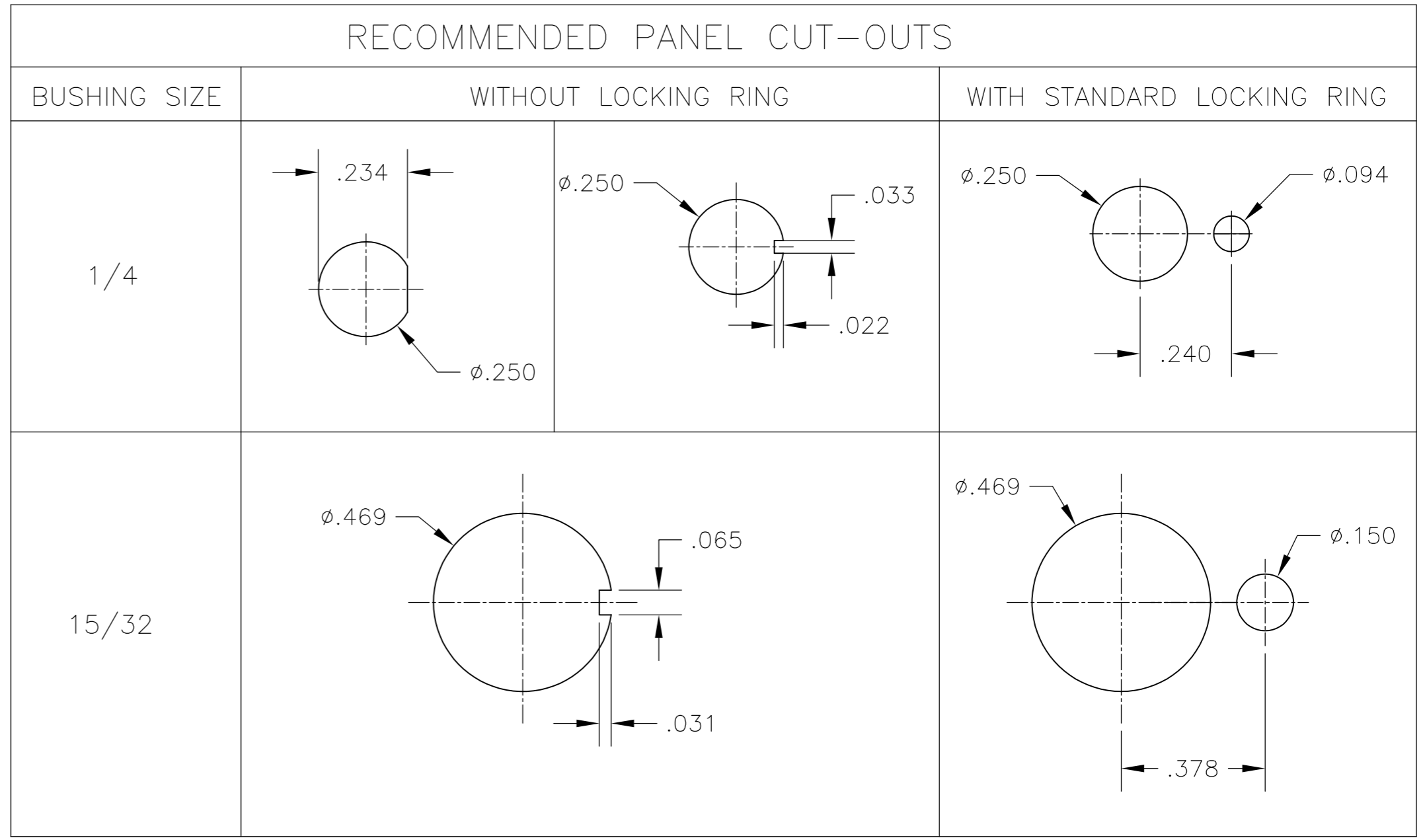

### MATERIALS CHART

COMPONENT NAME	BASE MATERIAL	FINISH
CASE	DAP, RED, UL94 V-0	
FRAME	STAINLESS STEEL	
B TERMINALS & CONTACTS	COPPER	GOLD OVER NICKEL
G TERMINALS & CONTACTS	COPPER	GOLD OVER SILVER
Q TERMINALS & CONTACTS	COPPER	.000400 SILVER
ACTUATOR	PHENOLIC, BLACK, UL94 V-1	
LEVER	BRASS	CHROME
BUSHING	BRASS	NICKEL
SPRING	MUSIC WIRE	
SUPPORT BRACKET	BRASS	TIN
PIVOT PIN	STEEL	NICKEL
LOCK WASHER	STAINLESS STEEL	
LOCKING RING	STAINLESS STEEL	
NUTS	C3604BD BRASS	NICKEL
TERMINAL SEAL	EPOXY	

THIS DRAWING IS A CONTROLLED DOCUMENT.		DWN	M. ZITTO	14APR05																			
DIMENSIONS: INCHES		CHK	M. ZITTO	-																			
TOLERANCES UNLESS OTHERWISE SPECIFIED:		APVD	M. ZITTO	-																			
<table border="1"> <tr><td>0 PLC</td><td>±</td><td>-</td></tr> <tr><td>1 PLC</td><td>±</td><td>-</td></tr> <tr><td>2 PLC</td><td>±</td><td>-</td></tr> <tr><td>3 PLC</td><td>±</td><td>.010</td></tr> <tr><td>4 PLC</td><td>±</td><td>-</td></tr> <tr><td>ANGLES</td><td>±</td><td>2°</td></tr> </table>		0 PLC	±	-		1 PLC	±	-	2 PLC	±	-	3 PLC	±	.010	4 PLC	±	-	ANGLES	±	2°	PRODUCT SPEC	-	NAME
0 PLC	±	-																					
1 PLC	±	-																					
2 PLC	±	-																					
3 PLC	±	.010																					
4 PLC	±	-																					
ANGLES	±	2°																					
MATERIAL	FINISH	APPLICATION SPEC	-	SIZE	A2																		
-		WEIGHT	-	CAGE CODE	00779																		
-		CUSTOMER DRAWING	-	DRAWING NO	C=1825139																		
-		SCALE	3:1	SHEET	4 OF 4																		
-		REV	A4	RESTRICTED TO	-																		



Компания «ЭлектроПласт» предлагает заключение долгосрочных отношений при поставках импортных электронных компонентов на взаимовыгодных условиях!

Наши преимущества:

- Оперативные поставки широкого спектра электронных компонентов отечественного и импортного производства напрямую от производителей и с крупнейших мировых складов;
- Поставка более 17-ти миллионов наименований электронных компонентов;
- Поставка сложных, дефицитных, либо снятых с производства позиций;
- Оперативные сроки поставки под заказ (от 5 рабочих дней);
- Экспресс доставка в любую точку России;
- Техническая поддержка проекта, помощь в подборе аналогов, поставка прототипов;
- Система менеджмента качества сертифицирована по Международному стандарту ISO 9001;
- Лицензия ФСБ на осуществление работ с использованием сведений, составляющих государственную тайну;
- Поставка специализированных компонентов (Xilinx, Altera, Analog Devices, Intersil, Interpoint, Microsemi, Aeroflex, Peregrine, Syfer, Eurofarad, Texas Instrument, Miteq, Cobham, E2V, MA-COM, Hittite, Mini-Circuits, General Dynamics и др.);

Помимо этого, одним из направлений компании «ЭлектроПласт» является направление «Источники питания». Мы предлагаем Вам помощь Конструкторского отдела:

- Подбор оптимального решения, техническое обоснование при выборе компонента;
- Подбор аналогов;
- Консультации по применению компонента;
- Поставка образцов и прототипов;
- Техническая поддержка проекта;
- Защита от снятия компонента с производства.



#### Как с нами связаться

**Телефон:** 8 (812) 309 58 32 (многоканальный)

**Факс:** 8 (812) 320-02-42

**Электронная почта:** [org@eplast1.ru](mailto:org@eplast1.ru)

**Адрес:** 198099, г. Санкт-Петербург, ул. Калинина, дом 2, корпус 4, литера А.