

# Low-frequency, high EMI resistance accelerometers

## HV100LF and HV200LF series

Wilcoxon's HV series are designed for low-frequency applications where high electrical isolation between the sensor and machine is required. HV sensors can withstand arcing between the sensor base and its internal electronics to levels as high as 6,000 volts. The sensors offer improved EMI resistance in areas where high electromagnetic interference occurs, such as wind turbines, railway systems and other high-voltage generators. Improvements in EFT and ESD resistance improve survivability during extreme transient events. The HV100LF/200LF series has superior performance down to 0.1 Hz.



### Models available

HV models	Output connector	Integral mounting	Sensitivity
HV100LF	4 pin, M12	M8 x 1.25	100 mV/g
HV100LF-500			500 mV/g
HV101LF		1/4-28 UNF	100 mV/g
HV101LF-500			500 mV/g
HV102LF		M6	100 mV/g
HV102LF-500			500 mV/g
HV200LF	2 pin, MIL-5015	1/4-28 UNF	100 mV/g
HV200LF-500			500 mV/g
HV201LF		M8 x 1.25	100 mV/g
HV201LF-500			500 mV/g
HV202LF		M6	100 mV/g
HV202LF-500			500 mV/g

### Key features

- Ultra low-frequency measurements
- Case-base isolated up to 6 kV
- Ideal for power generation applications
- Rapid shock recovery
- Improved EMI resistance
- Manufactured in an approved ISO 9001 facility

### Certifications



Note: Due to continuous process improvement, specifications are subject to change without notice. This document is cleared for public release.

# Low-frequency, high EMI resistance accelerometers



## HV100LF and HV200LF series

### SPECIFICATIONS

	LF series	LF-500 series
Sensitivity, $\pm 5\%$ , 25°C	100 mV/g	500 mV/g
Acceleration range, VDC > 22 V	80 g peak	10 g peak
Amplitude nonlinearity	1%	
Frequency response:		
$\pm 5\%$	0.35 - 5,000 Hz	
$\pm 10\%$	0.25 - 7,000 Hz	
$\pm 3$ dB	0.1 - 11,000 Hz	
Resonance frequency, nominal	28 kHz	
Transverse sensitivity, max	5% of axial	
Temperature response:		
-25°C	-10%	
+120°C	+15%	
Temperature range	-50° to +120° C	
Power requirement:		
Voltage source	18 - 30 VDC	
Current regulating diode	2 - 10 mA	
Dielectric withstand voltage between connector and surface:		
6,000 VDC	1 min.	
5,000 VAC	1 min.	
Electrical noise, equiv. g:		
Broadband 2.5 Hz to 25 kHz	400 $\mu$ g rms	250 $\mu$ g rms
Spectral 10 Hz	10 $\mu$ g/ $\sqrt{\text{Hz}}$	3 $\mu$ g/ $\sqrt{\text{Hz}}$
100 Hz	5 $\mu$ g/ $\sqrt{\text{Hz}}$	2 $\mu$ g/ $\sqrt{\text{Hz}}$
1,000 Hz	5 $\mu$ g/ $\sqrt{\text{Hz}}$	2 $\mu$ g/ $\sqrt{\text{Hz}}$
Output impedance, max	100 $\Omega$	300 $\Omega$
Impedance, between connector and base:		
DC	>100 G $\Omega$	
100 Hz	>100 M $\Omega$	
1.0 kHz	>10 M $\Omega$	
10 kHz	>1 M $\Omega$	
Bias output voltage	13 VDC	
Grounding	case isolated, internally shielded	
Vibration limit	500 g peak	
Shock limit	5,000 g peak	
Electromagnetic sensitivity, equiv. g, max	70 $\mu$ g/gauss	
Sealing	hermetic	
Base strain sensitivity, max	0.0002 g/ $\mu$ strain	
Sensing element design	PZT, shear	
Sensor case material	stainless steel	
Isolation material	ceramic	
Recommended cabling	J10 / J9T2A	

Function	Connector pin
signal	P1
to pin 3 inner shield	P2
common	P3
case	P4
connector shell	case

Function	Connector pin
signal	A
common	B
connector shell	case

See page 3 for further specifications, dimensions and drawings.

Note: Due to continuous process improvement, specifications are subject to change without notice. This document is cleared for public release.

# HV100LF series

SPECIFICATIONS		HV100LF/HV100LF-500	HV101LF/HV101LF-500	HV102LF/HV102LF-500
<b>Output connector<sup>1</sup></b>		4 pin M12	4 pin M12	4 pin M12
<b>Integral mounting</b>		M8 x 1.25	1/4-28 UNF	M6 x 1.00
<b>Dimensions:</b>	<b>A</b>	1.98 in. (50.3 mm)	1.98 in. (50.3 mm)	1.98 in. (50.3 mm)
	<b>B</b>	0.33 in. (8.4 mm)	0.33 in. (8.4 mm)	0.33 in. (8.4 mm)
	<b>C</b>	1.21 in. (30.8 mm)	1.21 in. (30.8 mm)	1.21 in. (30.8 mm)
<b>Weight</b>		126 grams (4.44 oz)	126 grams (4.44 oz)	126 grams (4.44 oz)

**Notes:** <sup>1</sup> For best performance, it is recommended that the connector shell be tied to the cable shield.

Recommended connector: R75S

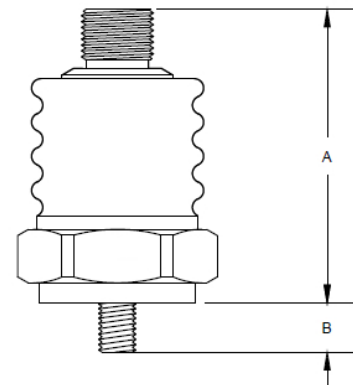
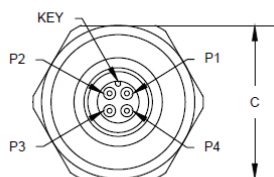

# HV200LF series

SPECIFICATIONS		HV200LF/HV200LF-500	HV201LF/HV201LF-500	HV202LF/HV202LF-500
<b>Output connector<sup>1</sup></b>		2 pin MIL-5015	2 pin MIL-5015	2 pin MIL-5015
<b>Integral mounting</b>		1/4-28 UNF	M8 x 1.25	M6 x 1.00
<b>Dimensions:</b>	<b>A</b>	2.21 in. (56.0 mm)	2.21 in. (56.0 mm)	2.21 in. (56.0 mm)
	<b>B</b>	0.33 in. (8.4 mm)	0.33 in. (8.4 mm)	0.33 in. (8.4 mm)
	<b>C</b>	1.21 in. (30.8 mm)	1.21 in. (30.8 mm)	1.21 in. (30.8 mm)
<b>Weight</b>		122 grams (4.35 oz)	122 grams (4.35 oz)	122 grams (4.35 oz)

**Notes:** <sup>1</sup> For best performance, it is recommended that the connector shell be tied to the cable shield.

Recommended connector: R6Q

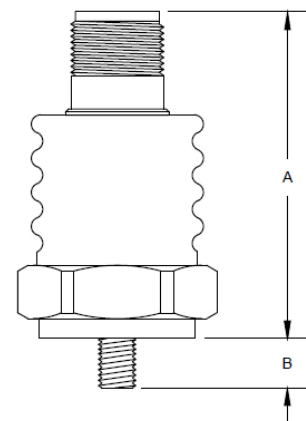
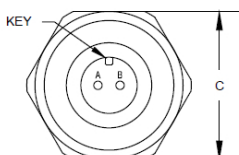

Note: Due to continuous process improvement, specifications are subject to change without notice.  
This document is cleared for public release.



Компания «ЭлектроПласт» предлагает заключение долгосрочных отношений при поставках импортных электронных компонентов на взаимовыгодных условиях!

Наши преимущества:

- Оперативные поставки широкого спектра электронных компонентов отечественного и импортного производства напрямую от производителей и с крупнейших мировых складов;
- Поставка более 17-ти миллионов наименований электронных компонентов;
- Поставка сложных, дефицитных, либо снятых с производства позиций;
- Оперативные сроки поставки под заказ (от 5 рабочих дней);
- Экспресс доставка в любую точку России;
- Техническая поддержка проекта, помощь в подборе аналогов, поставка прототипов;
- Система менеджмента качества сертифицирована по Международному стандарту ISO 9001;
- Лицензия ФСБ на осуществление работ с использованием сведений, составляющих государственную тайну;
- Поставка специализированных компонентов (Xilinx, Altera, Analog Devices, Intersil, Interpoint, Microsemi, Aeroflex, Peregrine, Syfer, Eurofarad, Texas Instrument, Miteq, Cobham, E2V, MA-COM, Hittite, Mini-Circuits, General Dynamics и др.);

Помимо этого, одним из направлений компании «ЭлектроПласт» является направление «Источники питания». Мы предлагаем Вам помощь Конструкторского отдела:

- Подбор оптимального решения, техническое обоснование при выборе компонента;
- Подбор аналогов;
- Консультации по применению компонента;
- Поставка образцов и прототипов;
- Техническая поддержка проекта;
- Защита от снятия компонента с производства.



#### Как с нами связаться

**Телефон:** 8 (812) 309 58 32 (многоканальный)

**Факс:** 8 (812) 320-02-42

**Электронная почта:** [org@eplast1.ru](mailto:org@eplast1.ru)

**Адрес:** 198099, г. Санкт-Петербург, ул. Калинина, дом 2, корпус 4, литера А.