

THIS DRAWING IS UNPUBLISHED. RELEASED FOR PUBLICATION  
 © COPYRIGHT - By - ALL RIGHTS RESERVED.

LOC	DIST	REVISIONS					
		P	LTR	DESCRIPTION	DATE	DWN	APVD
-	-		A3	REVISED PER ECO-12-011771	26JUN12	KH	JO

- 1 MATERIAL :  
 HOUSING : THERMOPLASTIC(PA6T), UL94V-0, BLACK COLOR  
 CONTACT : BRASS.
- 2 FINISH :  
 CONTACT: 0.2μm [8μ"] MIN. GOLD PLATED ON CONTACT AREA  
 2.54μm [100μ"] MIN. MATTE TIN PLATED ON SOLDER TAILS,  
 1.27μm [50μ"] MIN. NICKEL UNDERPLATED OVER ALL
- 3 FINISH :  
 CONTACT: 0.2μm [8μ"] MIN. GOLD PLATED OVER ALL  
 1.27μm [50μ"] MIN. NICKEL UNDERPLATED OVER ALL
- 4 WAVE SOLDER CAPABLE TO 265°C PER TE SPEC 109-202, CONDITION B.

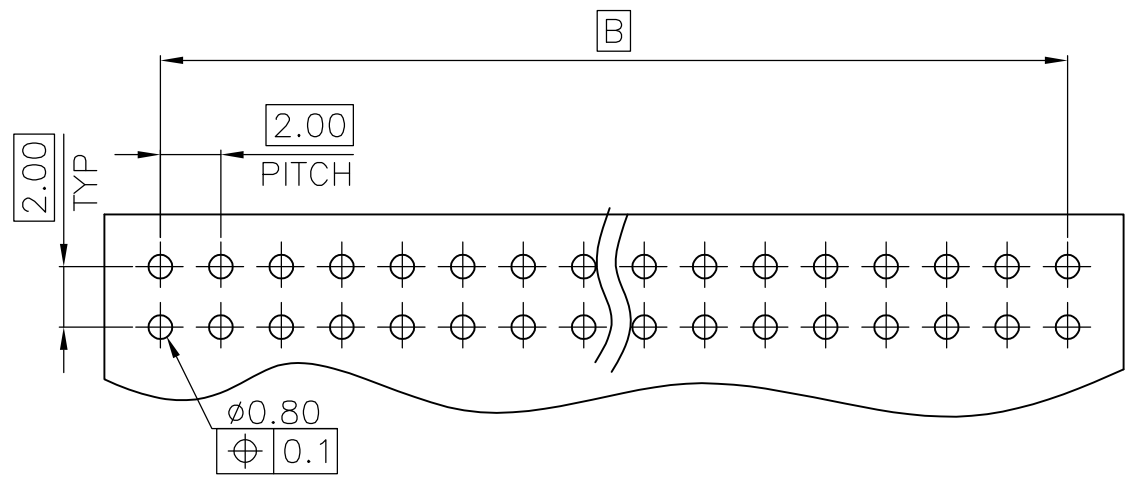
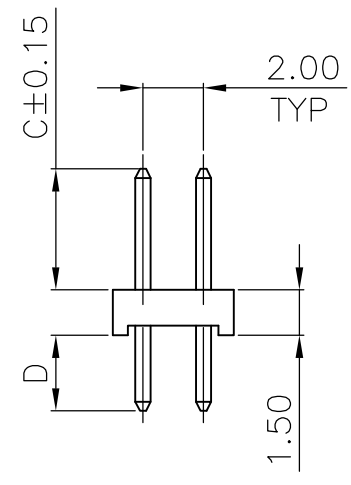
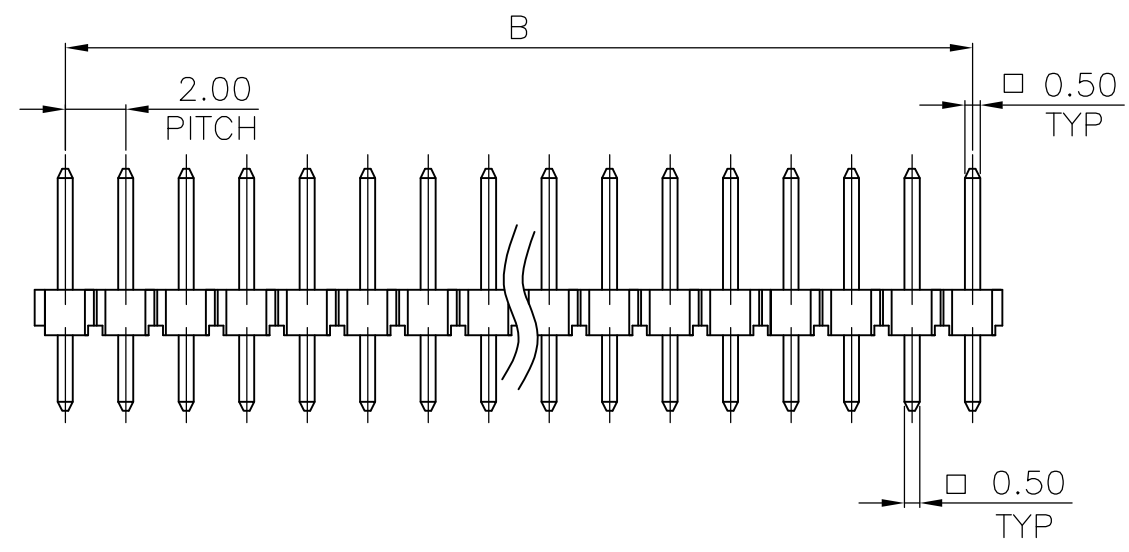
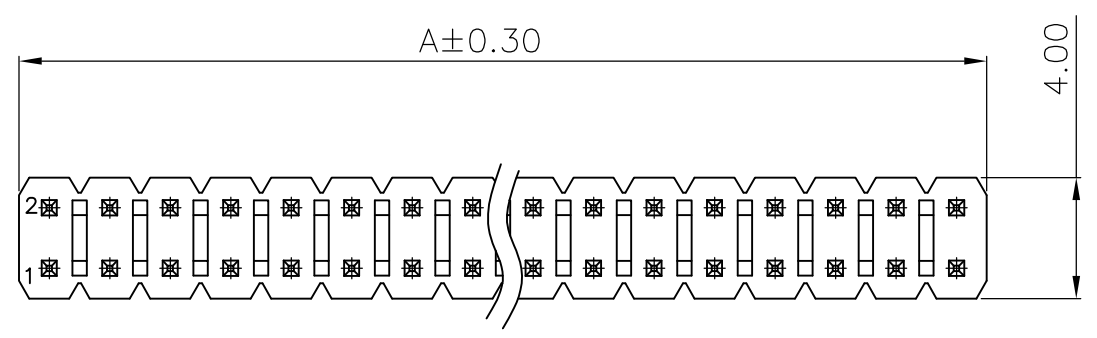

RECOMMENDED PCB LAYOUT  
 TOP VIEW, TOLERANCE: ±0.05

FINISH	WEIGHT(g)	D	C	B	A	POSITION NUMBER	PART NUMBER
3	0.18	0.8	4.00	8.00	10.00	10	2041051-2
2	0.3	2.50	7.80	8.00	10.00	10	2041051-1

THIS DRAWING IS A CONTROLLED DOCUMENT.		DWN S. CHIEN 24APR2008	<b>STE</b> TE Connectivity			
DIMENSIONS: mm		CHK S. CHIEN 24APR2008				
TOLERANCES UNLESS OTHERWISE SPECIFIED:		APVD W. KODAMA 24APR2008	NAME			
0 PLC ± -		PRODUCT SPEC	AMPMODU 2.00MM PITCH POST HDR VERTICAL MOUNT TYPE			
1 PLC ± 0.30		APPLICATION SPEC	-			
2 PLC ± 0.20		108-57197	SIZE	CAGE CODE	DRAWING NO	RESTRICTED TO
3 PLC ± -		501-57197	A3	00779	C-2041051	-
4 PLC ± -		WEIGHT See Table				
ANGLES ± 3°		CUSTOMER DRAWING	SCALE -	SHEET 1 OF 5	REV A3	
MATERIAL SEE NOTE	FINISH SEE NOTE					

THIS DRAWING IS UNPUBLISHED. RELEASED FOR PUBLICATION

© COPYRIGHT - By - ALL RIGHTS RESERVED.

LOC	DIST	REVISIONS			
P	LTR	DESCRIPTION	DATE	DWN	APVD
-	-	SEE SHEET 1	-	-	-

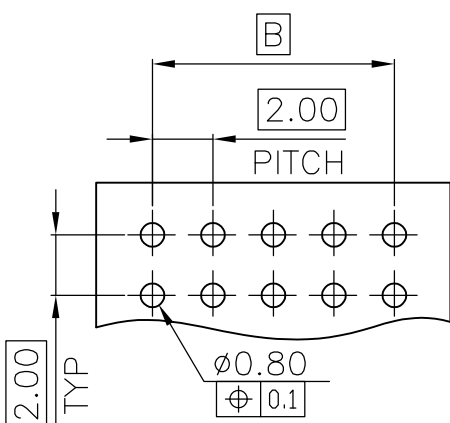
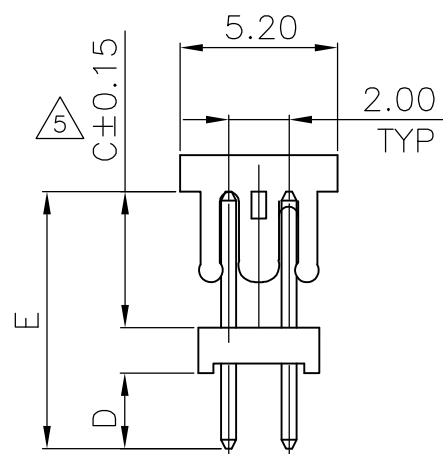
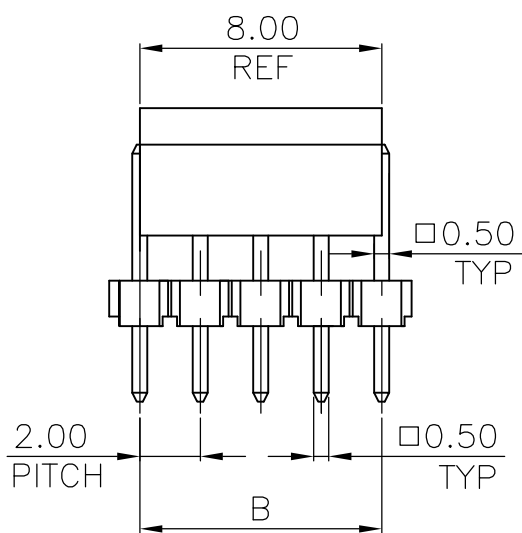
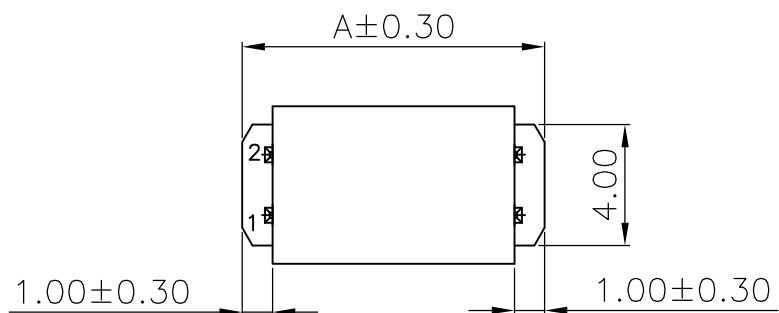

RECOMMENDED PCB LAYOUT  
TOP VIEW, TOLERANCE:±0.05

- 1 MATERIAL :  
HOUSING : PA6T WITH 30% GF, UL 94V-0, BLACK COLOR  
CAP: LCP WITH 30% GF, UL 94V-0, BLACK COLOR.  
CONTACT : BRASS.
- 2 FINISH :  
CONTACT: 0.2µm [8µ"] MIN. GOLD PLATED ON CONTACT AREA  
2.54µm [100µ"] MIN. MATTE TIN PLATED ON SOLDER TAILS,  
1.27µm [50µ"] MIN. NICKEL UNDERPLATED OVER ALL
- 3 FINISH :  
CONTACT: 0.2µm [8µ"] MIN. GOLD PLATED OVER ALL  
1.27µm [50µ"] MIN. NICKEL UNDERPLATED OVER ALL
- 4 WAVE SOLDER CAPABLE TO 265°C PER TE SPEC 109-202, CONDITION B.
- 5 DIMENSION IS FROM TOP OF HOUSING TO BOTTOM  
LEDGE OF CAP

FINISH	WEIGHT(g)	DIMENSIONS					POSITION NUMBER	PART NUMBER
		E	D	C	B	A		
2	0.50	11.04	2.50	7.04	8.00	10.00	10	1-2041051-4
2	0.47	10.16	2.50	6.16	8.00	10.00	10	1-2041051-3
2	0.40	8.50	2.50	4.50	8.00	10.00	10	1-2041051-2
3	0.32	6.30	0.8	4.00	8.00	10.00	10	2041051-4
2	0.48	11.80	2.50	7.80	8.00	10.00	10	2041051-3

THIS DRAWING IS A CONTROLLED DOCUMENT.		DWN	TE Connectivity AMPMODU 2.00MM PITCH POST HDR VERTICAL MOUNT TYPE				
DIMENSIONS: mm		CHK					
TOLERANCES UNLESS OTHERWISE SPECIFIED:		APVD					
0 PLC ± - 1 PLC ± 0.30 2 PLC ± 0.20 3 PLC ± - 4 PLC ± - ANGLES ± 3°		PRODUCT SPEC					
MATERIAL SEE NOTE		FINISH SEE NOTE	APPLICATION SPEC	SIZE	CAGE CODE	DRAWING NO	RESTRICTED TO
			WEIGHT See Table	A3	00779	C-2041051	
CUSTOMER DRAWING			SCALE	SHEET	REV		
			-	2 OF 5	A3		

THIS DRAWING IS UNPUBLISHED.

RELEASED FOR PUBLICATION

---

© COPYRIGHT - By -

ALL RIGHTS RESERVED.

LOC	DIST	REVISIONS			
P	LTR	DESCRIPTION	DATE	DWN	APVD
-	-	SEE SHEET 1	-	-	-

HEADER(P=2.00)  
DUAL ROW SERIES(1.50)

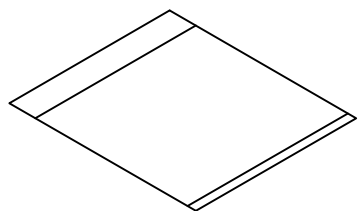
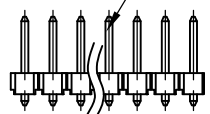

BUSINESS  
ESTABLISHMENT LABEL

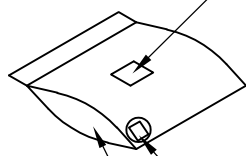

LABEL

BAG  
140MM(L)X110MM(W)

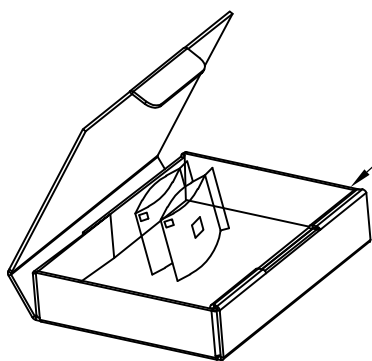
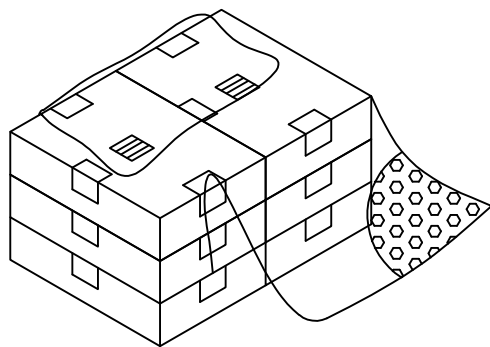

INNER CARTON

1 EACH BAG SHALL BE INCLUDED:  
\* DESICCANT

2 DIMENSIONS:  
CARTON:490\*394\*245MM  
INNER CARTON:B3B,218\*185\*80MM  
PE BAG:140\*110\*0.08MM

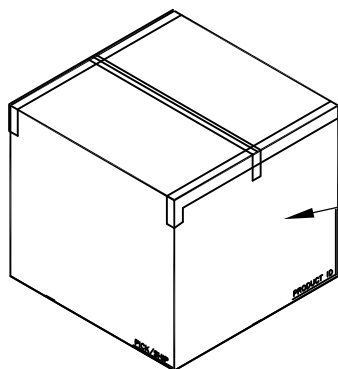
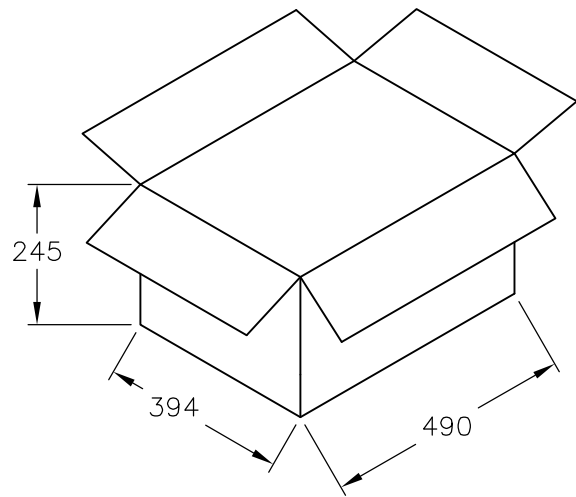

BOX

7.96 KG	5.18 KG	600	8	6	28800 PCS	10	2041051-2
7.1 KG	4.32 KG	300	8	6	14400 PCS	10	2041051-1
GROSS WEIGHT	NET WEIGHT	PCS/BAG	BAGS /INNER CARTON	INNER CARTON /CARTON	QUANTITY	NO. OF POSTS	PART NUMBER

THIS DRAWING IS A CONTROLLED DOCUMENT.		DWN	 <b>TE Connectivity</b> NAME AMPMODU 2.00MM PITCH POST HDR VERTICAL MOUNT TYPE				
DIMENSIONS: mm		CHK					
TOLERANCES UNLESS OTHERWISE SPECIFIED:		APVD					
0 PLC ± - 1 PLC ± - 2 PLC ± - 3 PLC ± - 4 PLC ± - ANGLES ± -		PRODUCT SPEC					
MATERIAL		FINISH	APPLICATION SPEC	SIZE	CAGE CODE	DRAWING NO	RESTRICTED TO
			WEIGHT	A3	00779	C-2041051	
CUSTOMER DRAWING			SCALE	SHEET	3 OF 5	REV	A3

THIS DRAWING IS UNPUBLISHED. RELEASED FOR PUBLICATION  
 © COPYRIGHT - By - ALL RIGHTS RESERVED.

LOC	DIST	REVISIONS					
		P	LTR	DESCRIPTION	DATE	DWN	APVD
-	-	-	-	SEE SHEET 1	-	-	-

- MATERIAL :  
 COVER TAPE : PT+ABS, COLOR: TRANSPARENT  
 CARRIER TAPE : PS  
 REEL : PS  
 SHIPPING BOX: CORRUGATED FIBER
- PEELING RESISTANCE : 10gf~130gf (for 12mm~56mm)
- PEELING SPEED : 300mm/MINUTES

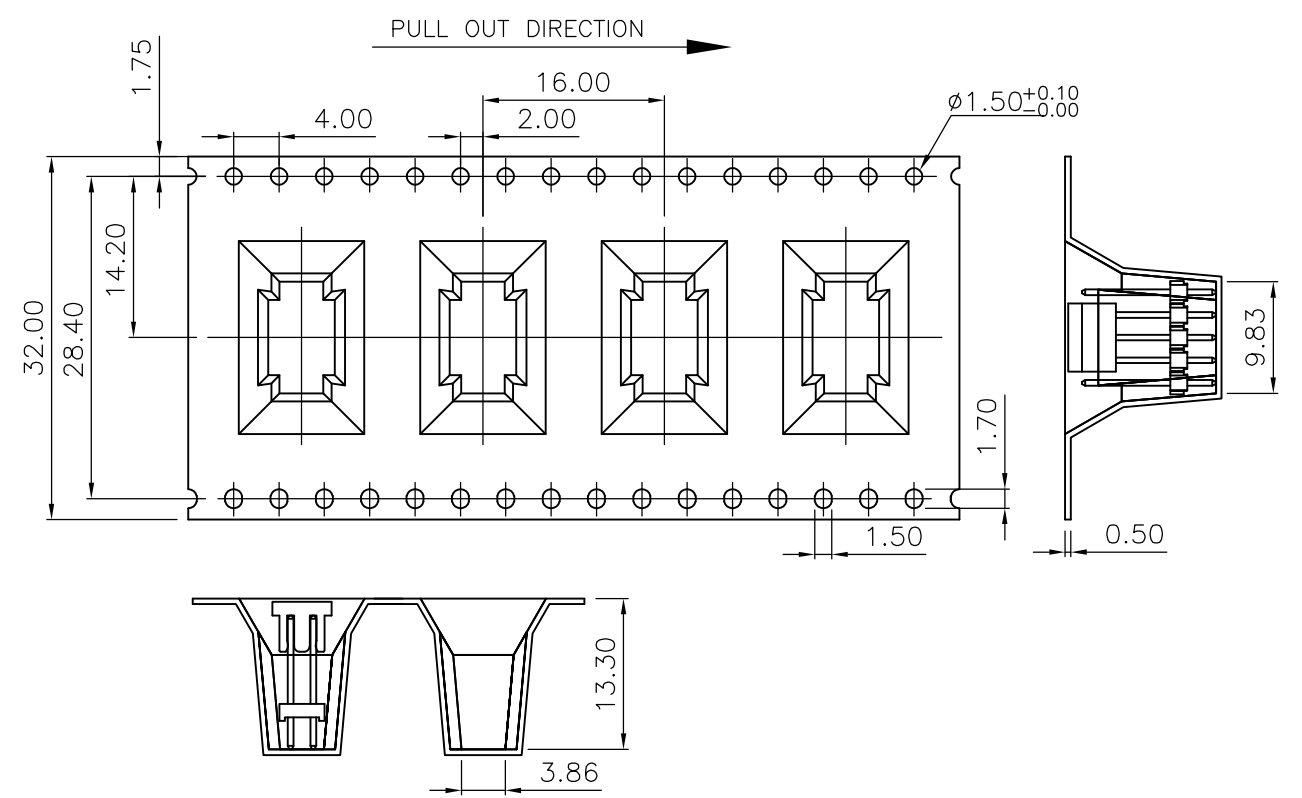
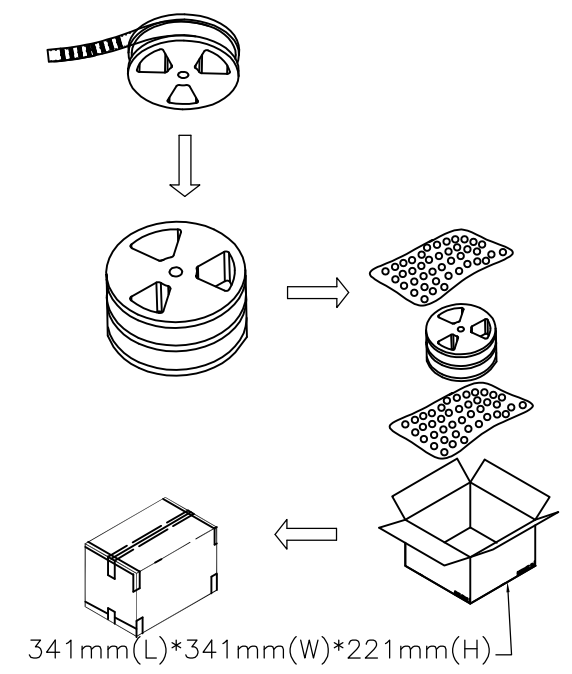
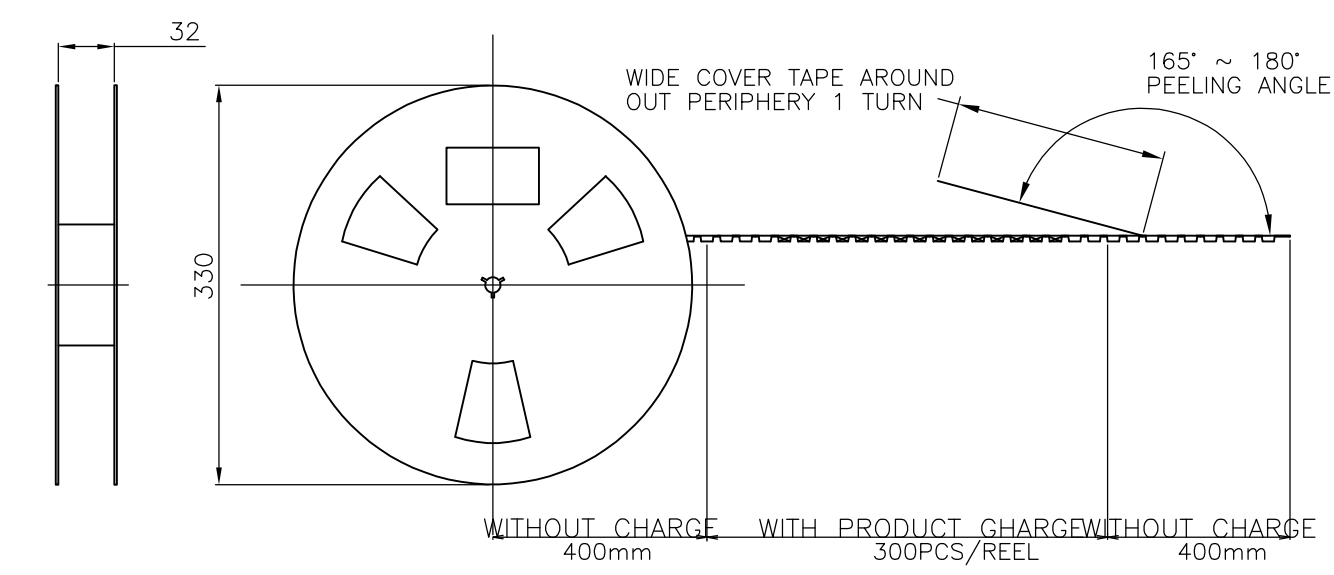

3.02 KG	0.50 KG	1250	250	10	1-2041051-4
3.02 KG	0.47 KG	1250	250	10	1-2041051-3
3.02 KG	0.60 KG	1250	250	10	2041051-3
GROSS WEIGHT	NET WEIGHT	PCS/CARTON	PCS/REEL	NO. OF POSTS	PART NUMBER

THIS DRAWING IS A CONTROLLED DOCUMENT.		DWN		TE Connectivity AMPMODU 2.00MM PITCH POST HDR VERTICAL MOUNT TYPE	
DIMENSIONS: mm		CHK			
TOLERANCES UNLESS OTHERWISE SPECIFIED:		APVD			
0 PLC ± - 1 PLC ± - 2 PLC ± - 3 PLC ± - 4 PLC ± - ANGLES ± -		PRODUCT SPEC			
MATERIAL		FINISH		NAME	
				SIZE	
				CAGE CODE	
				DRAWING NO	
				RESTRICTED TO	
		WEIGHT		A3 00779 C-2041051	
		CUSTOMER DRAWING		SCALE	
				SHEET 4 OF 5	
				REV A3	

THIS DRAWING IS UNPUBLISHED.

RELEASED FOR PUBLICATION

---

© COPYRIGHT - By -

ALL RIGHTS RESERVED.

LOC	DIST	REVISIONS					
		P	LTR	DESCRIPTION	DATE	DWN	APVD
-	-	-	-	SEE SHEET 1	-	-	-

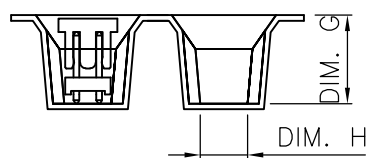
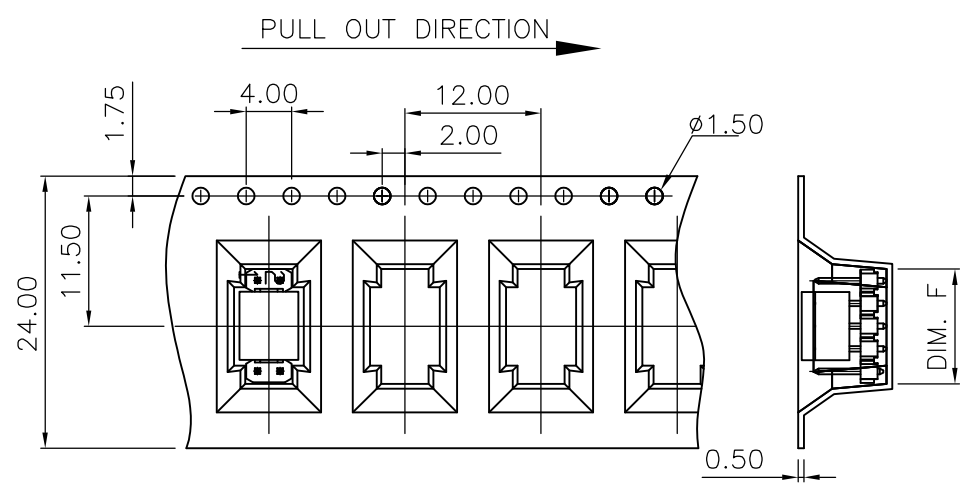
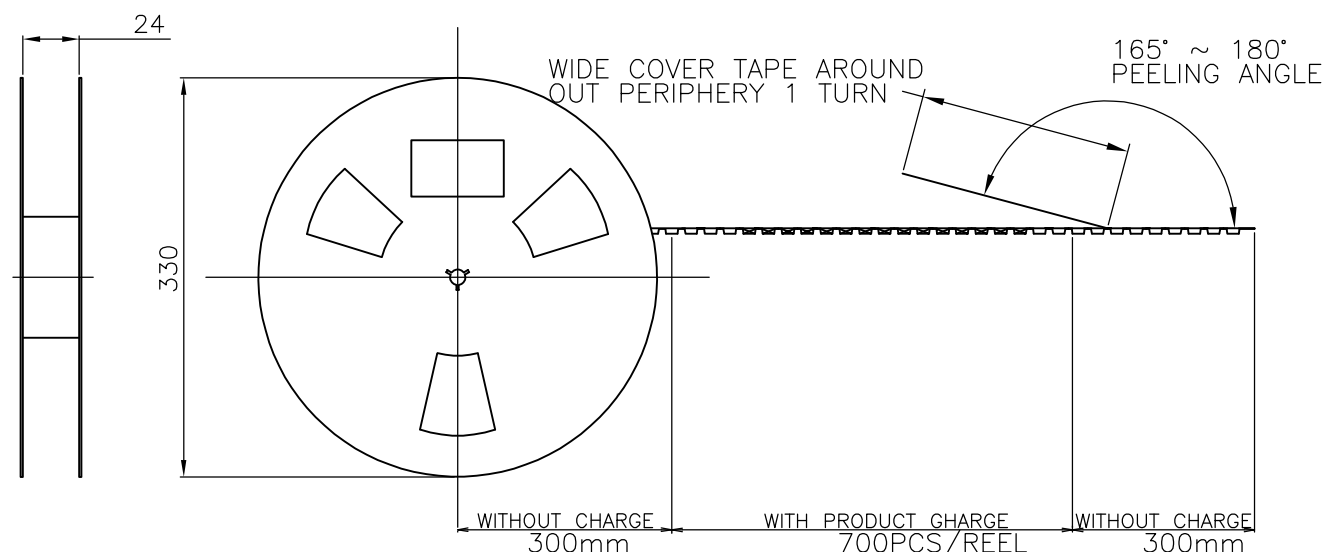

- MATERIAL :  
COVER TAPE : PT+ABS, COLOR: TRANSPARENT  
CARRIER TAPE : PS  
REEL : PS  
SHIPPING BOX: CORRUGATED FIBER
- PEELING RESISTANCE : 10gf~130gf (for 12mm~56mm)
- PEELING SPEED : 300mm/MINUTES

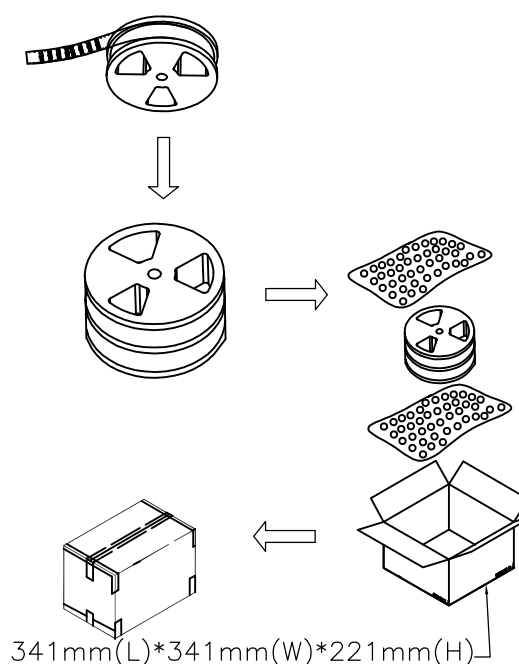

3.86	10.10	9.82	3.95 KG	1.05 KG	2400	400	10	1-2041051-2
4.16	7.80	10.12	4.34 KG	1.44 KG	4200	700	10	2041051-4
DIM.H	DIM.G	DIM.F	GROSS WEIGHT	NET WEIGHT	PCS/CARTON	PCS/REEL	NO. OF POSTS	PART NUMBER

THIS DRAWING IS A CONTROLLED DOCUMENT.		DWN	-			TE Connectivity			
DIMENSIONS: mm		CHK	-						NAME
TOLERANCES UNLESS OTHERWISE SPECIFIED:		APVD	-			AMPMODU 2.00MM PITCH POST HDR VERTICAL MOUNT TYPE			
0 PLC ± -		PRODUCT SPEC	-			-			
1 PLC ± -		APPLICATION SPEC	-			-			
2 PLC ± -		WEIGHT	-			SIZE	CAGE CODE	DRAWING NO	RESTRICTED TO
3 PLC ± -		CUSTOMER DRAWING		SCALE	A3 00779		C=2041051	-	
4 PLC ± -		SHEET		5 OF 5	REV		A3		
ANGLES ± -		FINISH							



Компания «ЭлектроПласт» предлагает заключение долгосрочных отношений при поставках импортных электронных компонентов на взаимовыгодных условиях!

Наши преимущества:

- Оперативные поставки широкого спектра электронных компонентов отечественного и импортного производства напрямую от производителей и с крупнейших мировых складов;
- Поставка более 17-ти миллионов наименований электронных компонентов;
- Поставка сложных, дефицитных, либо снятых с производства позиций;
- Оперативные сроки поставки под заказ (от 5 рабочих дней);
- Экспресс доставка в любую точку России;
- Техническая поддержка проекта, помощь в подборе аналогов, поставка прототипов;
- Система менеджмента качества сертифицирована по Международному стандарту ISO 9001;
- Лицензия ФСБ на осуществление работ с использованием сведений, составляющих государственную тайну;
- Поставка специализированных компонентов (Xilinx, Altera, Analog Devices, Intersil, Interpoint, Microsemi, Aeroflex, Peregrine, Syfer, Eurofarad, Texas Instrument, Miteq, Cobham, E2V, MA-COM, Hittite, Mini-Circuits, General Dynamics и др.);

Помимо этого, одним из направлений компании «ЭлектроПласт» является направление «Источники питания». Мы предлагаем Вам помощь Конструкторского отдела:

- Подбор оптимального решения, техническое обоснование при выборе компонента;
- Подбор аналогов;
- Консультации по применению компонента;
- Поставка образцов и прототипов;
- Техническая поддержка проекта;
- Защита от снятия компонента с производства.



#### Как с нами связаться

**Телефон:** 8 (812) 309 58 32 (многоканальный)

**Факс:** 8 (812) 320-02-42

**Электронная почта:** [org@eplast1.ru](mailto:org@eplast1.ru)

**Адрес:** 198099, г. Санкт-Петербург, ул. Калинина, дом 2, корпус 4, литера А.