

# HLMP-Nxxx

## T-1 (3 mm) Auto Insertable LED Lamps



### Data Sheet



**HLMP-N305, HLMP-N405, HLMP-NG0x,  
HLMP-NL06, HLMP-NH04**

#### Description

This family of 3 mm LED Lamps is capable of withstanding automatic insertion and wave soldering processes.

Designed with a thick epoxy flange and soft leadframe material, it is ideal for clinch and cut operations.

#### Applications

- General purpose
- High volume manufacturing

#### Features

- T-1 (3 mm) auto insertable package
- AllnGaP SunPower intensity
- High light output
- Tinted diffused and tinted non-diffused lens options
- Wide viewing angle
- Variety of colors
- Available with straight or formed lead tape and reel options

#### Device Selection Guides

High Brightness Lamps		Package		Luminous Intensity,	Viewing Angle,	Package
Color	Part Number	Tinted	Diffused	Min. Iv @ 20 mA	2θ <sup>1/2</sup>	Outline
Red	HLMP-NG05	μ		90.2	45	A
	HLMP-NG07	μ		90.2	60	B
Amber	HLMP-NL06	μ		96.2	60	B
Red Orange	HLMP-NH04			90.2	60	B

High Efficiency Lamps		Package		Luminous Intensity,	Viewing Angle,	Package
Color	Part Number	Tinted	Diffused	Min. Iv @ 10 mA	2θ <sup>1/2</sup>	Outline
GaP Yellow	HLMP-N305	X		14.7	45	A
GaP Orange	HLMP-N405	X		13.8	45	A

Note:

1. 2θ<sup>1/2</sup> is the off axis angle where the luminous intensity is 1/2 the on axis intensity.

## Package Dimensions

### Package Outline "A"

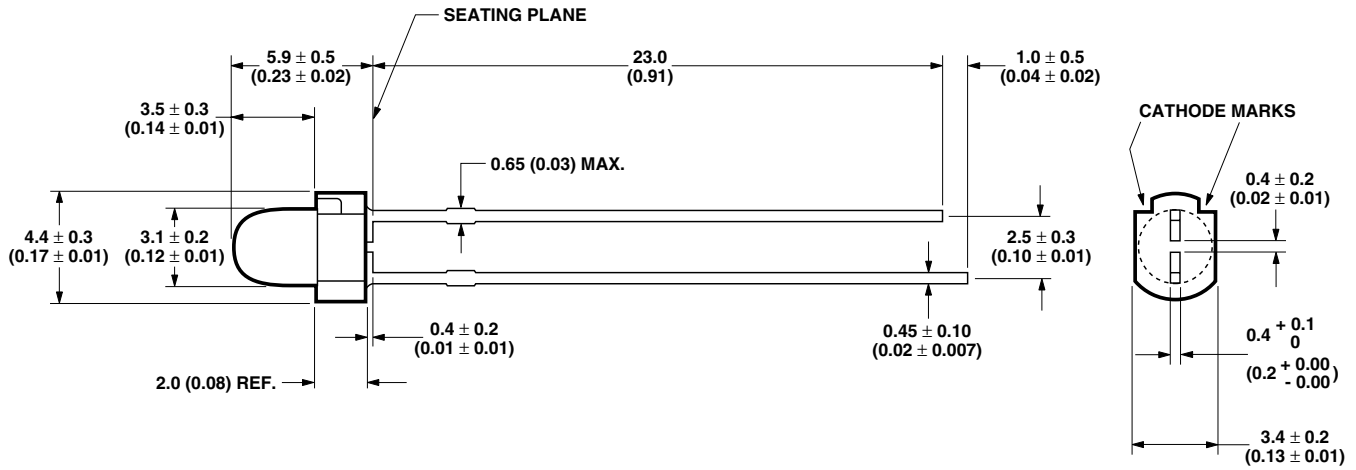

### Package Outline "B"

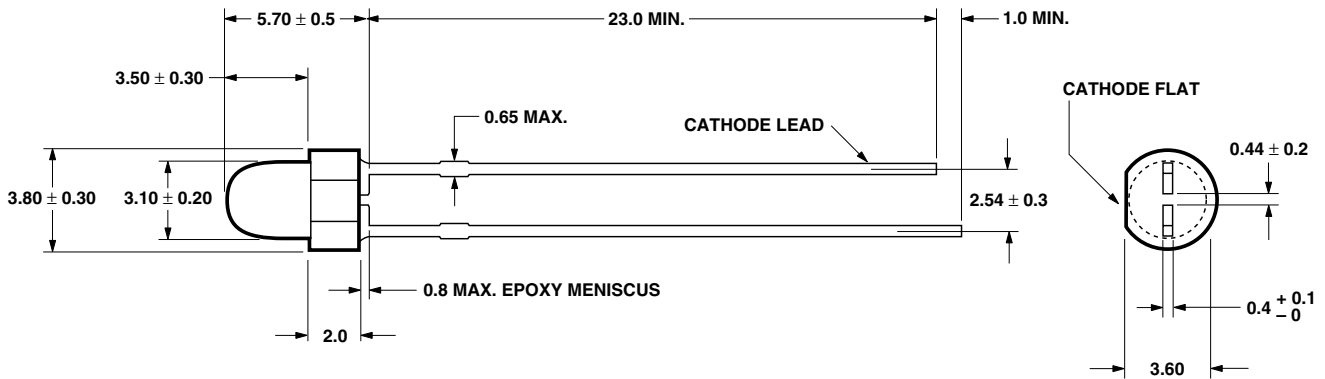

#### NOTES:

1. ALL DIMENSIONS ARE IN MILLIMETERS (INCHES).
2. LEADS ARE MILD STEEL. SOLDER COATED.
3. EPOXY MENISCUS OF 0.8 mm (0.03 in.) MAXIMUM MAY EXTEND TO THE LEADS.

## Part Numbering System

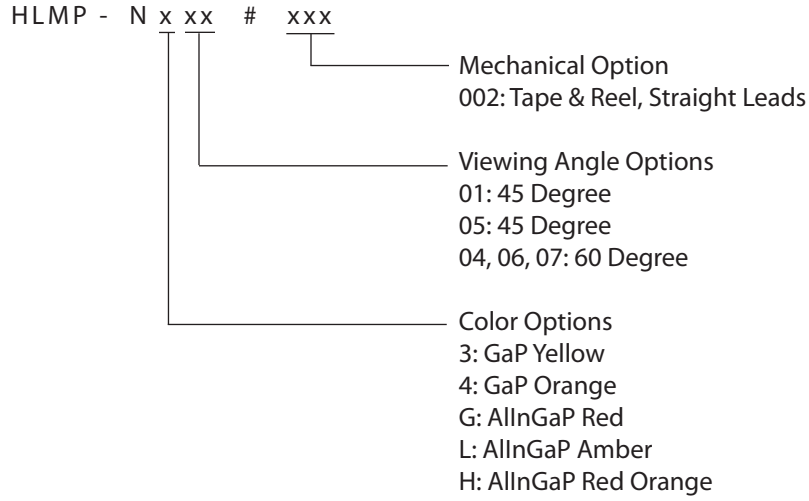

## Absolute Maximum Ratings at $T_A = 25\text{ }^\circ\text{C}$

Parameter	Orange	Yellow	AllnGaP Red Orange, Amber & Red	Units
DC Forward Current <sup>[1]</sup>	30	20	30 <sup>[2,3]</sup>	mA
Reverse Voltage ( $I_r = 100\text{ }\mu\text{A}$ )		5		V
Junction Temperature, $T_{j\text{max}}$		110		$^\circ\text{C}$
Storage Temperature Range		-40 to +85		$^\circ\text{C}$
Operating Temperature Range		-20 to +85	-40 to +85	$^\circ\text{C}$

### Notes:

1. See Figure 4 for maximum current derating vs. ambient temperature.
2. Suggested minimum DC current: 10 mA.
3. Maximum Peak Pulsed Forward Current: 50 mA, 30 mA average.

### Electrical Characteristics at $T_A = 25^\circ\text{C}$

Part Number	Forward Voltage $V_f$ (Volts)			Capacitance C (pF), $V_f = 0, f = 1 \text{ MHz}$	Thermal Resistance $R_{\theta J-PIN}$ ( $^\circ\text{C/W}$ )	Speed of Response $\tau_s$ (ns) Time Constant $e^{-t}/\tau_s$
	Typ.	Max.	$I_f$ (mA)	Typ.		Typ.
HLMP-N30x	2.00	2.6	10	15	290	90
HLMP-N40x	1.90	2.6	10	4	290	280
HLMP-NL06 <sup>[1]</sup>	2.02	2.4	20	40	240	20
HLMP-NG0x <sup>[1]</sup>	1.90	2.4	20	40	240	20
HLMP-NH04	1.94	2.4	20	40	250	20

Note:

1. Please contact your Avago Sales Representative about operating currents below 10 mA.

### Optical Characteristics at $T_A = 25^\circ\text{C}$

Part Number	Luminous Intensity		Typ. Peak Wavelength (nm)	Typ. Dominant Wavelength (nm)	Typ. Spectral Half Width	Luminous Efficacy Width (lm/W)
	Min.	$I_f$ (mA)				
HLMP-NG05	90.2	20	635	626	17	150
HLMP-NG07	90.2	20	635	626	17	150
HLMP-NL06	96.2	20	592	590	17	480
HLMP-N305	14.7	10	583	585	36	500
HLMP-N405	13.8	10	600	602	37	380
HLMP-NH04	90.2	20	621	615	17	235

Notes:

1. The luminous intensity,  $I_v$ , is measured at the mechanical axis of the lamp package. The actual peak of the spatial radiation pattern may not be aligned with this axis.
2. The dominant wavelength,  $\lambda_d$ , is derived from the CIE Chromaticity Diagram and represents the color of the device.
3. The radiant intensity,  $I_e$ , in watts per steradian, may be found from the equation  $I_e = I_v/\eta_v$ , where  $I_v$  is the luminous intensity in candelas and  $\eta_v$  is the luminous efficacy in lumens/watt.

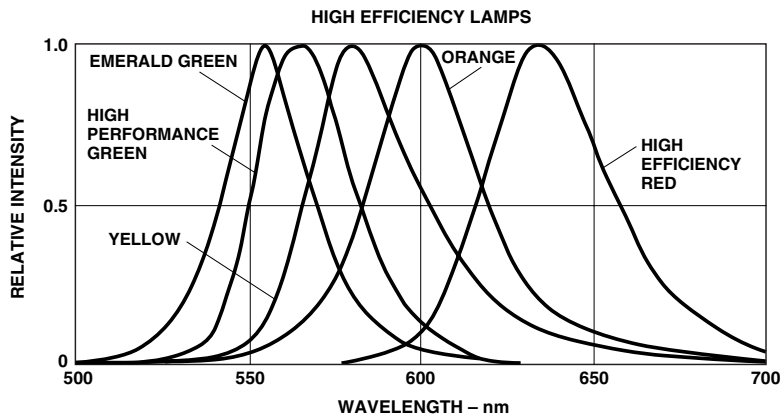
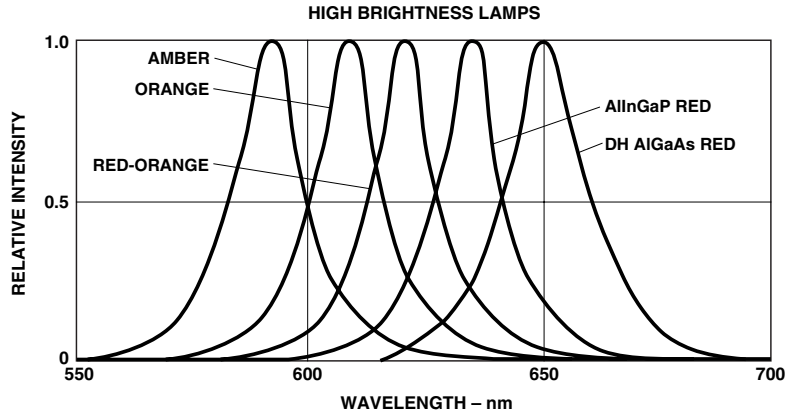

Figure 1. Relative intensity vs. peak wavelength.

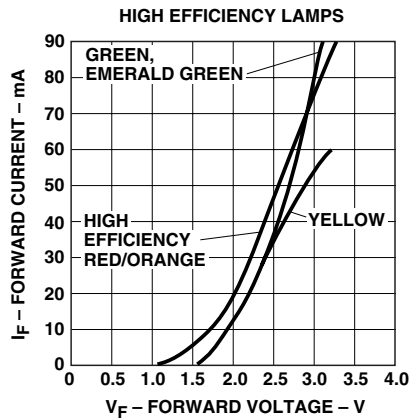
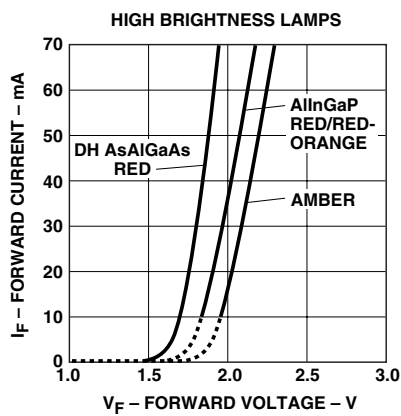

Figure 2. Forward current vs. forward voltage.

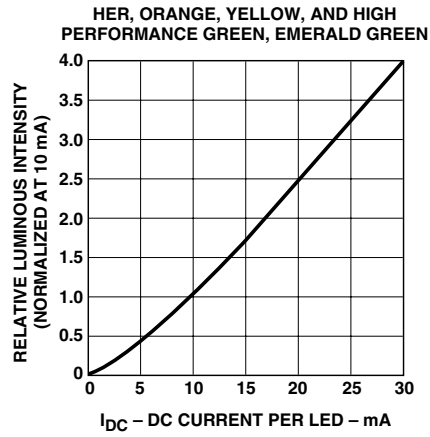
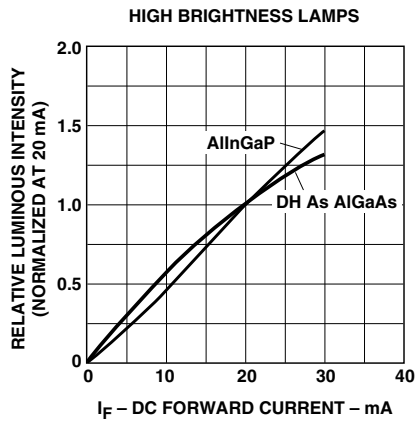

Figure 3. Relative luminous intensity vs. forward current.

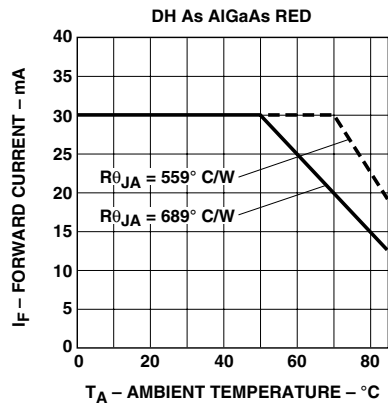
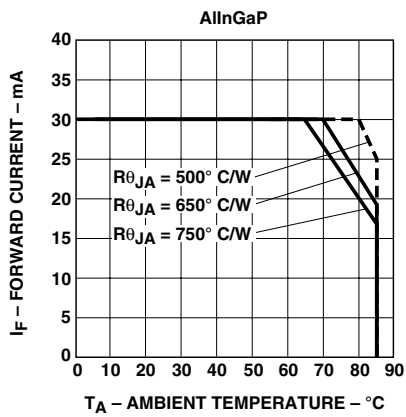

Figure 4. Maximum forward DC current vs. ambient temperature.

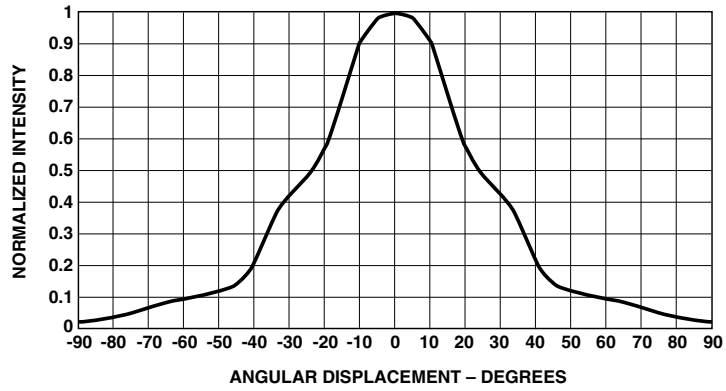

Figure 5. Representative spatial radiation pattern for 45° viewing angle.

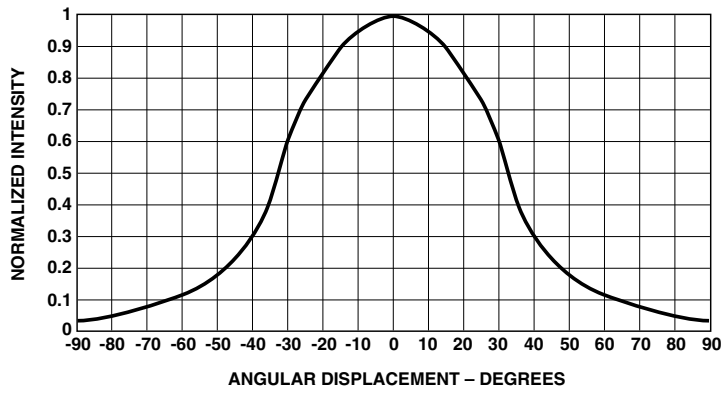

Figure 6. Representative spatial radiation pattern for 60° viewing angle.

### Intensity Bin Limits

Color	Bin	Intensity Range (mcd)	
		Min.	Max.
	H	13.8	27.6
	I	22.0	44.0
	J	35.2	70.4
	K	56.4	112.8
	L	90.2	180.4
	M	138.0	276.0
	N	200.0	400.0
	O	290.0	580.0
Red/Orange	P	500.0	1000.0
/Red-Orange	Q	700.0	1400.0
	R	1000.0	2000.0
	S	1400.0	2800.0
	T	2000.0	4000.0
	U	2900.0	5800.0
	V	4200.0	8400.0
	W	6000.0	12000.0
	X	8700.0	17400.0
	Y	12600.0	25200.0
	Z	18200.0	36400.0
	G	14.7	29.4
	H	23.5	47.0
	I	37.6	75.2
	J	60.1	120.2
	K	96.2	192.4
	L	147.0	294.0
	M	212.0	424.0
Yellow/Amber	N	300.0	600.0
	O	450.0	900.0
	P	700.0	1400.0
	Q	1000.0	2000.0
	R	1600.0	3200.0
	S	2600.0	5200.0
	T	4000.0	8000.0
	U	6500.0	13000.0
	V	10000.0	20000.0
	W	16000.0	30000.0

Maximum tolerance for each bin limit is  $\pm 18\%$ .

### Amber Color Bin Limits

(nm at 20 mA)

Bin Name	Min.	Max.
1	584.5	587.0
2	587.0	589.5
4	589.5	592.0
6	592.0	594.5

Tolerance for each bin limit is  $\pm 0.5$  nm.



## Color Categories

Color	Category #	Lambda (nm)	
		Min.	Max.
Yellow	1	582.0	584.5
	3	584.5	587.0
	2	587.0	589.5
	4	589.5	592.0
	5	592.0	593.0
Orange	1	597.0	599.5
	2	599.5	602.0
	3	602.0	604.5
	4	604.5	607.5
	5	607.5	610.5
	6	610.5	613.5
	7	613.5	616.5
	8	616.5	619.5

Tolerance for each bin limit is  $\pm 0.5$  nm.

## Taping Options

Option	Straight Lead		
	#002	#2CA	#2CD
Dimension "B"	-	-	-
Dimension "H"	20.5 $\pm$ 1.0 (0.81 $\pm$ 0.04)	18.0 $\pm$ 1.0 (0.71 $\pm$ 0.04)	20.5 $\pm$ 1.0 (0.81 $\pm$ 0.04)

Option	Formed Lead						
	#2UK	#2UL	#2UM	#2UN	#2UP	#2UQ	#2UR
Dimension "B"	12.0 $\pm$ 1.0 (0.47 $\pm$ 0.04)	9.0 $\pm$ 1.0 (0.35 $\pm$ 0.04)	10.0 $\pm$ 1.0 (0.39 $\pm$ 0.04)	11.0 $\pm$ 1.0 (0.43 $\pm$ 0.04)	13.0 $\pm$ 1.0 (0.51 $\pm$ 0.04)	14.0 $\pm$ 1.0 (0.55 $\pm$ 0.04)	15.0 $\pm$ 1.0 (0.59 $\pm$ 0.04)
Dimension "H"				16.0 $\pm$ 1.0 (0.63 $\pm$ 0.04)			

Units: mm (inches)

# Tape Outline Drawing

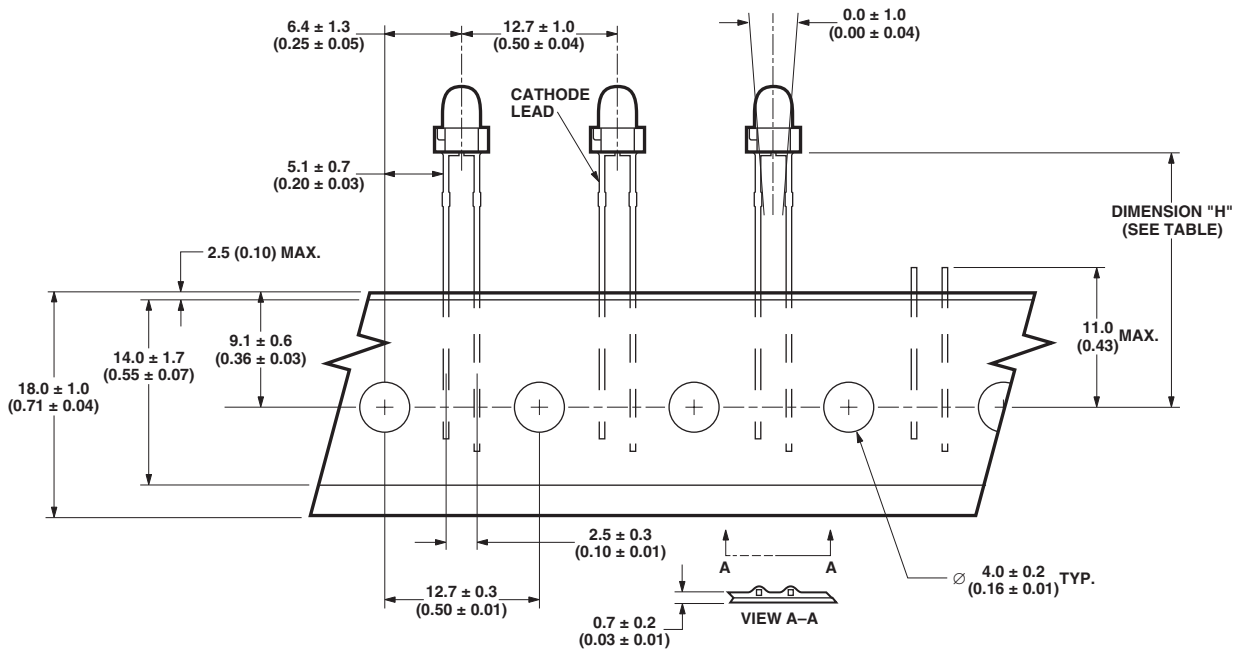

STRAIGHT LEAD

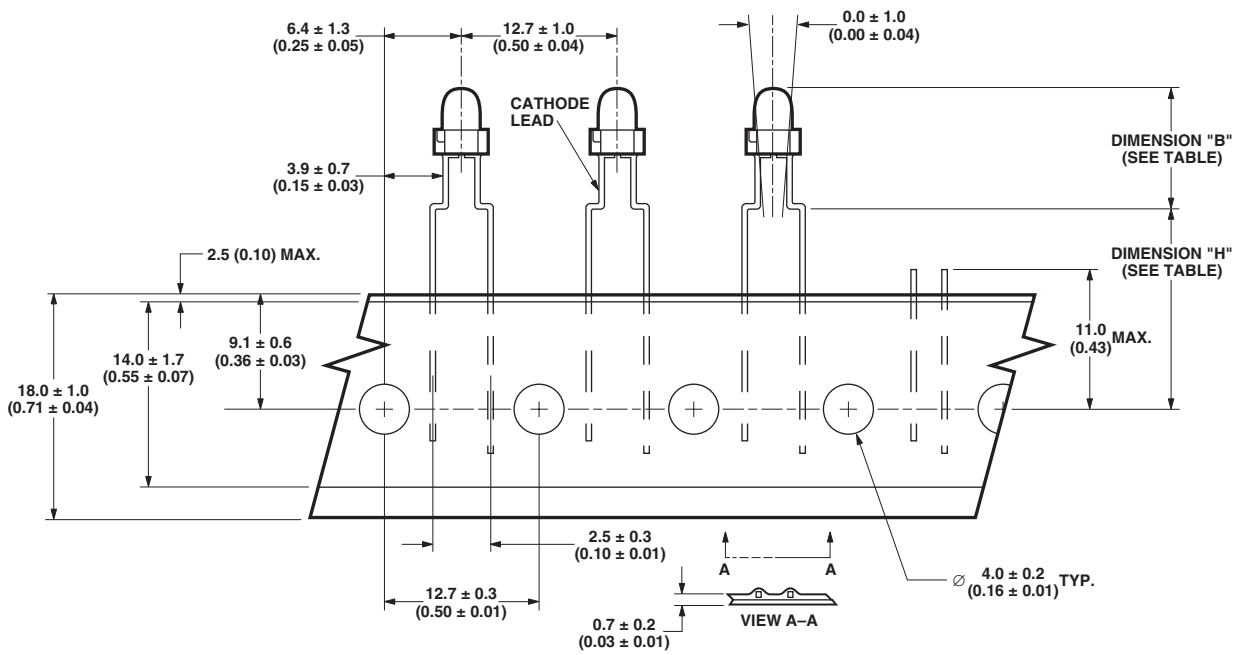

FORMED LEAD

## Package Options

Lead Option	Ammo Pack (1000 pcs.)	Tape & Reel (2000 pcs.)
Straight Lead	#2C —	#002
Formed Lead	#2U —	—

### AMMO PACK (for All options except #002)

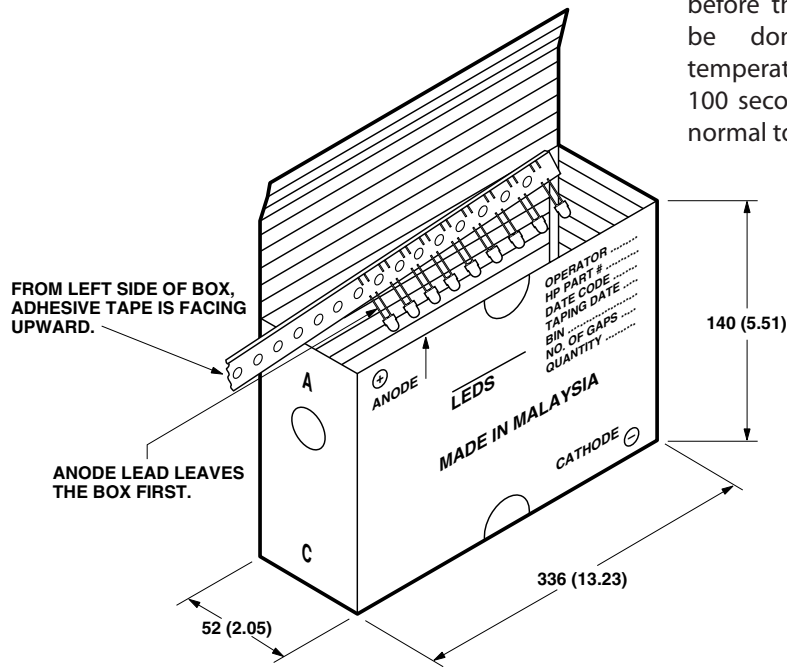

DIMENSIONS IN MILLIMETERS (INCHES).

## Recommended Assembly Condition

- A single-sided phenolic printed circuit board (PCB) is preferred. Double-sided PCB and other materials may cause greater lead stress. Recommended through-hole diameter is 0.93 to 1.03 mm. Leadlength below the PCB should be 1.5 to 2.0 mm, and the clinching angle (angle between the lead and PCB) should be  $30 \pm 10$  degrees.
- If SMT devices and an adhesive are used on the same pcb as these lamps, the adhesive should be cured before the lamps are auto-inserted. If curing must be done after lamp insertion, the cure temperature and time should not exceed  $140^{\circ}\text{C}$ , 100 seconds. This is the temperature of the surface normal to the IR source.

### TAPE & REEL (for option #002 only)

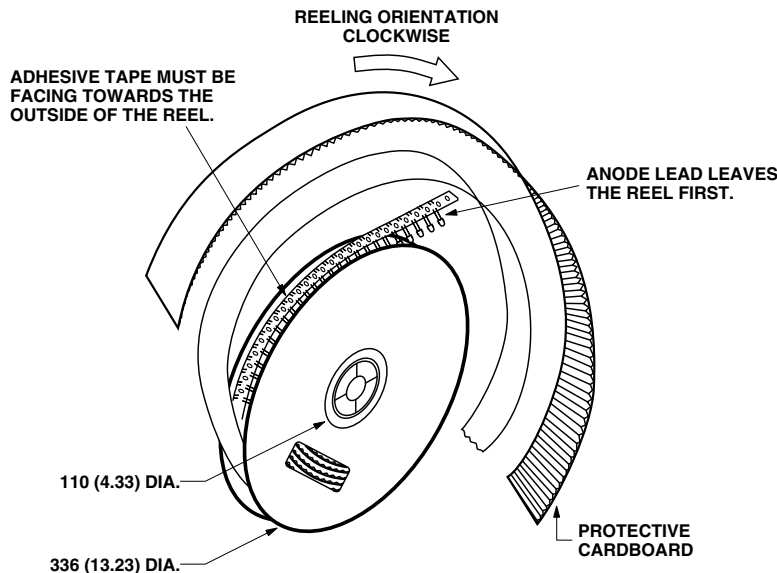

DIMENSIONS IN MILLIMETERS (INCHES).

## Precautions

### Lead Forming

- The leads of an LED lamp may be preformed or cut to length prior to insertion and soldering into PC board.
- If lead forming is required before soldering, care must be taken to avoid any excessive mechanical stress induced to LED package. Otherwise, cut the leads of LED to length after soldering process at room temperature. The solder joint formed will absorb the mechanical stress of the lead cutting from traveling to the LED chip die attach and wirebond.
- It is recommended that tooling made to precisely form and cut the leads to length rather than rely upon hand operation.

### Soldering Conditions

- Care must be taken during PCB assembly and soldering process to prevent damage to LED component.
- The closest LED is allowed to solder on board is 1.59 mm below the body (encapsulant epoxy) for those parts without standoff.
- Recommended soldering conditions:

		Manual Solder
<b>Wave Soldering</b>	<b>Dipping</b>	
Pre-heat Temperature	105 °C Max.	–
Pre-heat Time	30 sec Max.	–
Peak Temperature	250 °C Max.	260 °C Max.
Dwell Time	3 sec Max.	5 sec Max.

- Wave soldering parameter must be set and maintained according to recommended temperature and dwell time in the solder wave. Customer is advised to periodically check on the soldering profile to ensure the soldering profile used is always conforming to recommended soldering condition.
- If necessary, use fixture to hold the LED component in proper orientation with respect to the PCB during soldering process.
- Proper handling is imperative to avoid excessive thermal stresses to LED components when heated. Therefore, the soldered PCB must be allowed to cool to room temperature, 25°C, before handling.
- Special attention must be given to board fabrication, solder masking, surface plating and lead holes size and component orientation to assure solderability.
- Recommended PC board plated through hole sizes for LED component leads:

LED Component Lead Size	Diagonal	Plated Through Hole Diameter
0.457 x 0.457 mm (0.018 x 0.018 inch)	0.646 mm (0.025 inch)	0.976 to 1.078 mm (0.038 to 0.042 inch)
0.508 x 0.508 mm (0.020 x 0.020 inch)	0.718 mm (0.028 inch)	1.049 to 1.150 mm (0.041 to 0.045 inch)

Note: Refer to application note AN1027 for more information on soldering LED components.

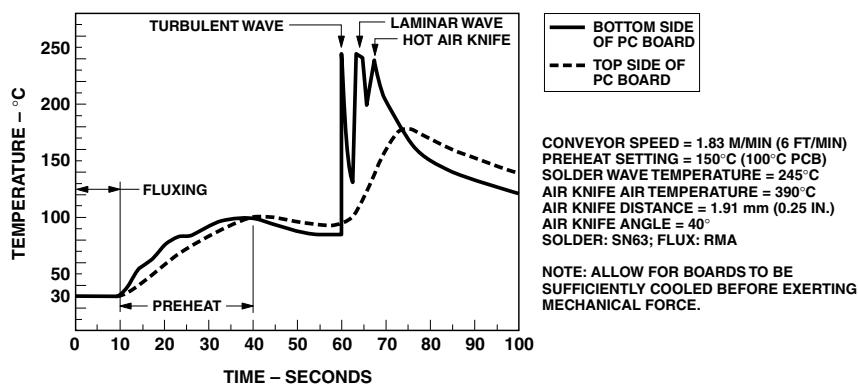

Figure 7. Recommended wave soldering profile.

For product information and a complete list of distributors, please go to our website: [www.avagotech.com](http://www.avagotech.com)

Avago, Avago Technologies, and the A logo are trademarks of Avago Technologies Limited in the United States and other countries. Data subject to change. Copyright © 2008 Avago Technologies Limited. All rights reserved. Obsoletes 5989-4257EN AV02-1014EN - January 23, 2008

**AVAGO**  
TECHNOLOGIES



Компания «ЭлектроПласт» предлагает заключение долгосрочных отношений при поставках импортных электронных компонентов на взаимовыгодных условиях!

Наши преимущества:

- Оперативные поставки широкого спектра электронных компонентов отечественного и импортного производства напрямую от производителей и с крупнейших мировых складов;
- Поставка более 17-ти миллионов наименований электронных компонентов;
- Поставка сложных, дефицитных, либо снятых с производства позиций;
- Оперативные сроки поставки под заказ (от 5 рабочих дней);
- Экспресс доставка в любую точку России;
- Техническая поддержка проекта, помощь в подборе аналогов, поставка прототипов;
- Система менеджмента качества сертифицирована по Международному стандарту ISO 9001;
- Лицензия ФСБ на осуществление работ с использованием сведений, составляющих государственную тайну;
- Поставка специализированных компонентов (Xilinx, Altera, Analog Devices, Intersil, Interpoint, Microsemi, Aeroflex, Peregrine, Syfer, Eurofarad, Texas Instrument, Miteq, Cobham, E2V, MA-COM, Hittite, Mini-Circuits, General Dynamics и др.);

Помимо этого, одним из направлений компании «ЭлектроПласт» является направление «Источники питания». Мы предлагаем Вам помощь Конструкторского отдела:

- Подбор оптимального решения, техническое обоснование при выборе компонента;
- Подбор аналогов;
- Консультации по применению компонента;
- Поставка образцов и прототипов;
- Техническая поддержка проекта;
- Защита от снятия компонента с производства.



#### Как с нами связаться

**Телефон:** 8 (812) 309 58 32 (многоканальный)

**Факс:** 8 (812) 320-02-42

**Электронная почта:** [org@eplast1.ru](mailto:org@eplast1.ru)

**Адрес:** 198099, г. Санкт-Петербург, ул. Калинина, дом 2, корпус 4, литера А.