



DC-DC Power over Ethernet Splitter 30W and 12VDC for Heaters, Illuminators and POE Cameras



Features

- Compatible with POE75U-1UP-R
- DC Good LED
- Non-Vented Case
- DC Power and PoE/Data Output
- No 2 Finger Classification
- Power IEEE802.3af Camera
- Full Protection OTP, OCP, OVP
- Gigabit Compatible
- 1 Year Warranty

Applications

- IP Cameras Heaters and Illuminators
- Access Controls

Safety Approvals

- CE

Mechanical Characteristics

- Length: 100mm (3.937in)
- Width: 56mm (2.205in)
- Height: 28mm (1.098in)
- Weight: 0.142Kg (0.313lb)

Output Specifications

Model	Output Power		PoE Load		DC Load	
	PoE	DC	Min	Max	Min	Max
POE21-120F-R*	25.5W at 42.5-57VDC	21W at 12VDC	15mA	600mA	0.0A	1.75A

*Model will not operate without Ultra PoE Power Injector or better

Reference files: [POE21_user_manual.pdf](#)

Phihong is not responsible for any error, and reserves the right to make changes without notice. Please visit our website at www.phihong.com for the most up-to-date specifications and contact information

INPUT:

Unit receives power from Pihong Ultra PoE Midspans using Cat 5e or Cat 6 wiring up to 100 meters per IEEE802.3. For information on Ultra PoE Midspans please go to www.midspans.com

DC Input Current

0.7A (DC) and 45VDC at maxload

DC Input Voltage Rating

45 – 57VDC for 12V
Pass through POE 42.5-7V

OUTPUT:**Regulation**

Line and Load $\pm 2\%$

Ripple

120mV max at 25°C on 12V

Efficiency

80% min at max load 48Vinput

O/P Voltage Protection

In case of output over voltage overload, crowbar will short. The output can be shorted permanently without damage.

ENVIRONMENTAL:**Temperature**

Operation	0 to +40°C
Non-operation	-20 to +65°C
Humidity	5 to 90%

Immunity

ESD: EN61000-4-2. Level 3

RS: EN61000-4-3. Level 2

Note: RS and CS tested with POE60U

EMC

EN55022 Class A

FCC Part 15, Class A

Dielectric withstand (HI-POT) Test

Primary to secondary: 2121VDC for 1 minute, 10mA

Insulation Resistance

Primary to Secondary: >10M Ohm 500V DC

FEATURES:**Indicators**

GREEN LED – Output power “ON”

Cable

Designed to operate up to 100 meters per IEEE 802.3, CAT 5e or CAT6

Input and Output Data Connector

RJ45

Output Connector

POE and data RJ45 Jack

DC Output

Center Positive Barrel 12mm x 2.1mm ID x 5.5mm OD. Tip is user changeable for other sizes



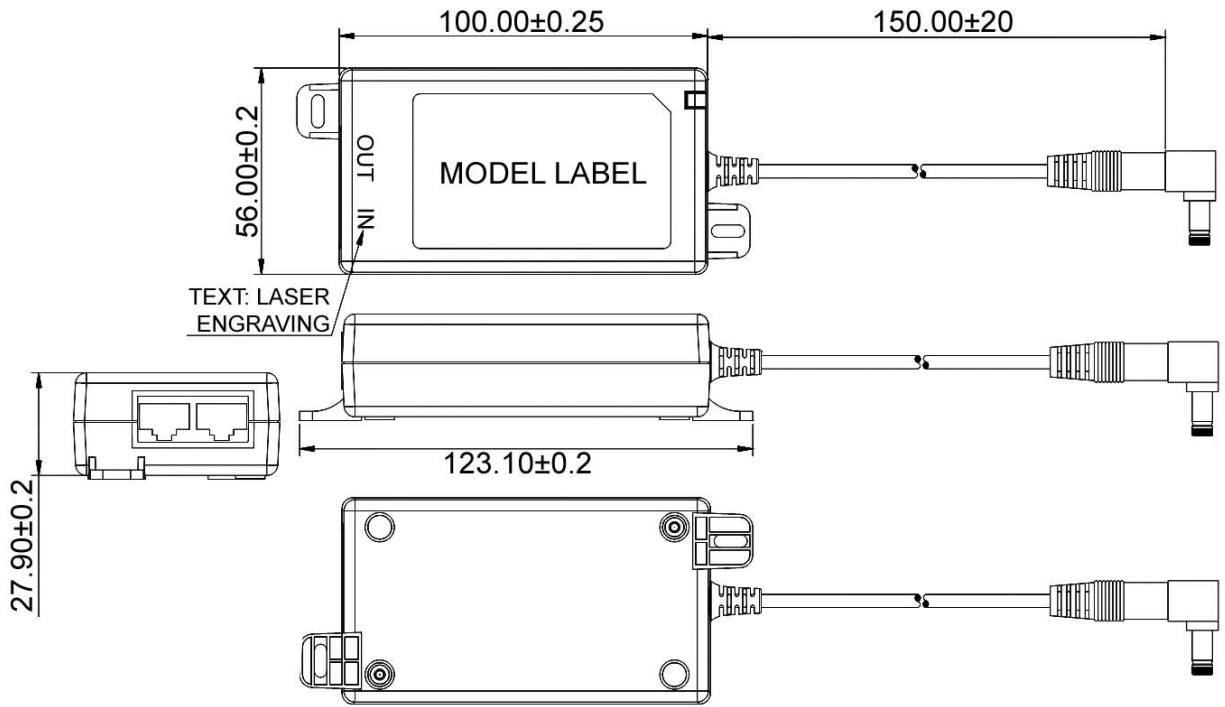

**Supplier's Declaration of Conformity
47 CFR § 2.1077 Compliance Information**

Phihong USA Corporation
47800 Fremont Boulevard
Fremont, CA 94538
Telephone: (510) 445-0100
www.phihong.com

NOTE: This model has/The models in this products series have been tested and found to comply with the limits for a Class B digital device, pursuant to part 15 of the FCC Rules. These limits are designed to provide reasonable protection against harmful interference in a residential installation. This equipment generates, uses and can radiate radio frequency energy and, if not installed and used in accordance with the instructions, may cause harmful interference to radio communications. However, there is no guarantee that interference will not occur in a particular installation. If this equipment does cause harmful interference to radio or television reception, which can be determined by turning the equipment off and on, the user is encouraged to try to correct the interference by one or more of the following measures:

- Reorient or relocate the receiving antenna.
- Increase the separation between the equipment and receiver.
- Connect the equipment into an outlet on a circuit different from that to which the receiver is connected.
- Consult the dealer or an experienced radio/TV technician for help.

Changes or modifications to equipment not expressly approved by PHIHONG could void the user's authority to operate the equipment.



Компания «ЭлектроПласт» предлагает заключение долгосрочных отношений при поставках импортных электронных компонентов на взаимовыгодных условиях!

Наши преимущества:

- Оперативные поставки широкого спектра электронных компонентов отечественного и импортного производства напрямую от производителей и с крупнейших мировых складов;
- Поставка более 17-ти миллионов наименований электронных компонентов;
- Поставка сложных, дефицитных, либо снятых с производства позиций;
- Оперативные сроки поставки под заказ (от 5 рабочих дней);
- Экспресс доставка в любую точку России;
- Техническая поддержка проекта, помощь в подборе аналогов, поставка прототипов;
- Система менеджмента качества сертифицирована по Международному стандарту ISO 9001;
- Лицензия ФСБ на осуществление работ с использованием сведений, составляющих государственную тайну;
- Поставка специализированных компонентов (Xilinx, Altera, Analog Devices, Intersil, Interpoint, Microsemi, Aeroflex, Peregrine, Syfer, Eurofarad, Texas Instrument, Miteq, Cobham, E2V, MA-COM, Hittite, Mini-Circuits, General Dynamics и др.);

Помимо этого, одним из направлений компании «ЭлектроПласт» является направление «Источники питания». Мы предлагаем Вам помощь Конструкторского отдела:

- Подбор оптимального решения, техническое обоснование при выборе компонента;
- Подбор аналогов;
- Консультации по применению компонента;
- Поставка образцов и прототипов;
- Техническая поддержка проекта;
- Защита от снятия компонента с производства.



Как с нами связаться

Телефон: 8 (812) 309 58 32 (многоканальный)

Факс: 8 (812) 320-02-42

Электронная почта: org@eplast1.ru

Адрес: 198099, г. Санкт-Петербург, ул. Калинина, дом 2, корпус 4, литера А.