



### FEATURES

- Scales and displays the output of 50:5A to 2000:5A current transformers
- 14 ranges (0-50 Amp to 0-2000 Amp)
- 2 Power options, 28 models
- Functionally complete:
  - On-board 5A current transformers
  - Scaling/interface circuitry
  - Precision A/D converters
  - Bright red or green LED displays
- Subminiature, 1.38" x 0.88" package
- Easy-to-read, 0.37"/9.4mm digits
- AC powered models: 120/220Vac @ 50/60Hz
- AC models can be "self-powered"
- +5-40V dc powered model
- 2000V isolation; UL/CSA recognized
- Digital replacements for analog ammeters

ACA5-20PC Series AC Ammeters are designed to scale and digitally display the output of standard, 5A-output current transformers (50:5A, 500:5A, 1000:5A, etc.). Simply pass the secondary/output wires of the "primary" CT through the ACA5-20PC's on-board CT, apply power to the meter, and you're instantly measuring ac currents over one of 14 ranges from 0-50A (with 100mA resolution) to 0-2000A (with 1A resolution). Because they accept outputs from previously installed high-current CT's, ACA5-20PC's can instantly bring modern digital precision to older ac ammeters.

The functionally complete ACA5-20PC ammeters incorporate scaling/interface circuitry to mate the on-board CT to a precision (3½ digit) A/D converter. The A/D's output directly drives the meters' large (0.37"/9.4mm digit height), easy-to-read, LED displays. All models employ auto-zero circuits, precision bandgap references, and super stable metal-film resistors for unsurpassed accuracy ( $\pm 0.15\%FS$ ) and stability.

ACA5-20PC meters are either ac (120/220Vac @ 50/60Hz) or dc (+5-40V) powered. AC models can be powered by the same ac supply whose current they are monitoring. All ACA5-20PCs provide 2000Vdc isolation between the measured ac current and their power supply, and all models are UL/CSA recognized.

Each meter is housed in a subminiature, 1.38" x 0.88", epoxy-encapsulated package whose behind-the-panel installation depth is 2 inches. Display color options include standard red, high-intensity red, and standard green. Each meter is supplied with a plastic bezel assembly with sealing gaskets (MPS DMS-BZL4-C).

### SIMPLIFIED SCHEMATIC DRAWING

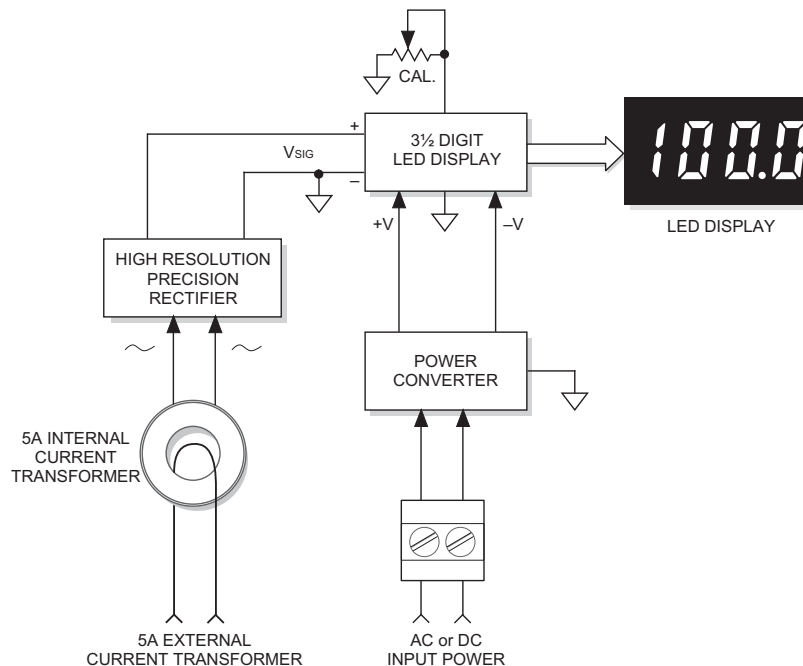

### Performance/Functional Specifications

Typical at TA = + 25°C, unless otherwise noted.

Full-Scale Current ① ②	Min.	Typ.	Max.	Units
All Models	–	–	5.0	Amps
Overcurrent Rating ①	1.5 x rated full-scale current			
<b>Performance</b>				
Sampling Rate	2.5 reading per second			
Accuracy ②	±0.15%FS ±6 Counts			
Measurement Type	Sine wave input, full-wave averaging, rms calibrated			
Temperature Drift (0 = +60°C)	–	±0.2	±0.4	Cnts/°C
Zero Reading	“–001”	“000”	“001”	Counts
Dielectric Withstanding Voltage	2000	–	–	Vdc
<b>Power Supply Voltage ③</b>				
ACA-20PC-X-AC1-RL (47-99Hz)	85	120	264	Vac
ACA-20PC-X-DC1-RL	+4.75	–	+40	Vdc
<b>Power Supply Current ④</b>				
ACA-20PC-X-AC1-RL (47-99Hz)	–	30	50	mA
ACA-20PC-X-DC1-RL	–	+8	+12	mAdc
<b>Power Supply Terminal Block</b>				
Wire Size and Type	16-22AWG (solid or stranded)			
Insulation Strip Length	0.25 inches			
Screw Tightening Torque	3.6 pounds/inches (0.4Nm)			
<b>Display</b>				
Display Type and Size	3½ digit, 0.37"/9.4mm high LED			
Overrange Indication	“1 _ _ _”			
Decimal Point	Model dependent. See Ordering Info.			
<b>Physical/Environmental</b>				
Operating Temperature	0	–	+60	°C
Storage Temperature	–40	–	+75	°C
Humidity (non-condensing)	0	–	95	%
Case Material	Polycarbonate			
Dimensions	1.38"W x 0.88"H. Depth is model dependent (see mechanical specification)			
Weight: (All models)	1.27 Ounces (36 grams) typical			

① The specified Full-Scale Current is the current carried by the single wire passing through the center hole of the ACA5-20PC's on-board CT. It is not the load current ultimately being measured, the Overcurrent Rating is a continuous rating that applies to the Full-Scale Current. It does not apply to any circuitry external to the meter.

② Listed accuracy specifications apply over the range of the Rated Full-Scale Current over frequencies of 45-450Hz.

③ Maximum reverse polarity protection on "DC1" models is –40Vdc.

④ All specified maximum power supply currents are steady-state. AC-powered models can draw larger surges at initial turn on.

### Ordering Information

#### ACA5 - 20PC - 1 - AC1 - RL - C

Input Range:  
(45-450Hz)

	5A CT Partno.
1 = 50.0A	7020-01036-0
2 = 75.0A	7020-01037-0
3 = 100.0A	7020-01038-0
4 = 150.0A	7020-01039-0
5 = 199.9A	7020-01040-0
6 = 250A	7020-01041-0
7 = 300A	39-3681407 *
8 = 400A	39-3681408 *
9 = 500A	39-3681409 *
10 = 600A	7020-01042-0
11 = 750A	7020-01043-0
12 = 1000A	7020-01044-0
13 = 1500A	7020-01045-0
14 = 1999A	7020-01046-0

\* Not RoHS Compliant

LED Color:

RL = Red Standard

Power Supply:

AC1 = 85-264Vac@50/60Hz

DC1 = +5-40Vdc



**Accessories:** DMS-20-CP Panel cutout punch

A DMS-BZL4 bezel assembly with sealing gasket is supplied with each ammeter.

**Matching 5A Current Transformers:** 5A current transformers for all ACA5-20PC ac ammeters are available from Murata Power Solutions at nominal cost. For technical information, visit [www.murata-ps.com](http://www.murata-ps.com), select Digital Panel Meters, then Accessories.

### TECHNICAL NOTES

**IMPORTANT!** To ensure safe and reliable operation, ACA5-20PC ammeters must be installed and serviced by qualified technical personnel. Contact Murata Power Solutions if there is any doubt regarding ammeter installation and/or operation.

- Measurement Type:** ACA5-20PC ac ammeters employ a full-wave-rectified, average responding, rms-calibrated circuit to measure the stepped-down output of their built-in L1 current transformer (CT). Stated accuracy specifications are measured using a sine-wave current at or close to the full-scale input level, at nominal line frequency.
- Calibration:** Periodic recalibration of ACA5-20PC ammeters is not required under normal, indoor operating environments. If user calibration is necessary, it should be performed by qualified technical personnel. Calibration is performed with potentially lethal voltages applied to the ACA5-20PC and its associated wiring, with the specified full-scale current flowing through the ammeter's built-in current transformer. A plastic, fully-insulated adjusting tool must be used to access the recessed calibration potentiometer located on the back of the meter (see Mechanical Specifications). Contact MPS if additional information is required regarding calibration, setup, or any other technical issue pertaining to ACA5-20PC ammeters.
- Wire Gauges and Fusing:** Wires specified in the Functional Specifications section must be used for making connections to ACA5-20PC Series ammeters. All power-supply and load wiring must be rated for the supply voltages and currents they will conduct and must comply with any code or application-mandated requirements pertaining to the user's specific installation.

ACA5-20PC series ammeters are not internally fused. Terminal block TB1 is to be used only for powering the ammeters' internal circuitry; it must not be used to supply power to external loads. The supply wires feeding these ammeters must be fused with a 0.25A/250V time delay/time lag fuse, in accordance with applicable regulatory codes.

Wire insulation must be stripped to within  $\pm 10\%$  of the stated dimensions, and wires should be inserted into TB1 such that their insulation is not pinched by the screw terminal.

4. **AC Supply Polarity and Grounding:** The two supply inputs, TB1-A and TB1-B, on all ac-powered ACA5-20PC ammeters are not in themselves polarity sensitive, that is, they have no internal "AC LO" or "AC HI" designations. Also, ac-powered ACA5-20PC ammeters do not include or require a connection to earth/chassis ground.
5. **Connector Torque Ratings:** It is important to tighten TB1's, screw-terminals to their rated torque specification of 3.6 pound-inches (0.4Nm). Proper tightening will minimize connector losses and ensure safe, reliable operation.
6. **DC-Powered Models:** DC-powered models draw minimal supply currents (120mA max.) and in most applications can be fused according to the supply wire's maximum amperage rating. However, be sure to check and comply with all applicable codes and regulations to ensure proper installation and operation.
7. **Isolation:** The on-board CT (L1) provides a minimum 2000Vdc isolation between the current-carrying conductor passing through its primary circuit and the ammeter supply voltage connected to TB1. This isolation rating only applies to applications in which the load wiring (i.e., the wire passing through L1's center hole) does not connect directly or indirectly to TB1-A or TB1-B.
8. **CT Precautions:** In normal operation, a 5A current transformer's secondary circuit operates at a very low voltage due to its closed-loop operation and its low burden resistance. However, a CT can still generate potentially lethal voltages if its output current is suddenly interrupted. For example, loose CT secondary connections can cause a condition referred to as "inductive kick". Inductive kick can generate extremely high voltages across intermittent secondary connections.  
  
Therefore, implementing connections to any 5A current transformer's output leads must only be performed with zero load-current, that is, with no power applied to the load circuit.
9. **CT Connections and Grounding:** Some applications require connect-

ing one of the external 5A CT's output leads to earth/chassis ground. In the USA, consult the latest revision of the National Electrical Code (NEC) for more information regarding CT grounding.

After all mechanical assembly is completed, connect the two output leads of the external 5A CT to each other after they are run through L1's center hole. Pressure-style connectors (commonly referred to as "wire nuts") are acceptable as long as they are rated for the number of conductors and voltage involved.

10. **Replacing Analog Panel Meters:** ACA5-20PC ammeters can be used as direct replacements for analog panel meters driven by 5A CT's. All wiring operations must be performed with both the load and the supply power sources completely de-energized.

### PANEL INSTALLATION

All connections to ACA5-20PC Series ammeters must be made after the ammeter is securely attached to the panel and with all load and supply voltages de-energized (off).

Care should be exercised when passing conductors through the ammeter's built-in CT. The installed wire positions should be such that minimal forces are applied to the built-in CT, TB1, or to the ammeter itself. In high-vibration environments, proper strain reliefs must be used for all load and supply wiring.

To ensure a secure panel-mount installation, MPS recommends using the DMS-BZL4-C bezel assembly (with sealing gasket) supplied with each ammeter. See Mechanical Specifications for detailed cutout and ammeter dimensions.

Following the four-step sequence shown in Figure 2 — being careful not to apply excessive force or twisting motions — insert the ammeter into the panel opening. When using the DMS-BZL4-C, install its sealing gasket so it is positioned between the ammeter's front flange and panel front surface (see Mechanical Specifications). Be sure to use and securely tighten all four screws supplied with the bezel assembly.

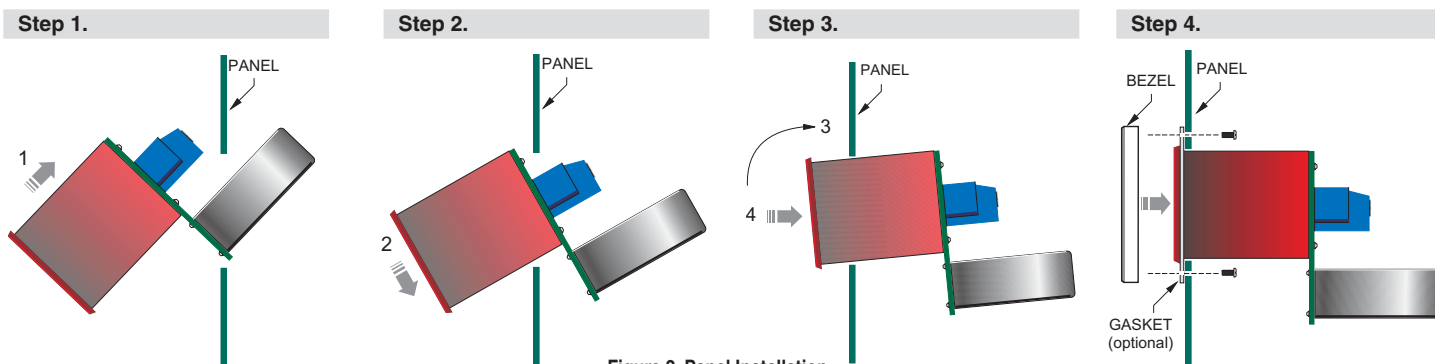

Figure 2. Panel Installation

**TYPICAL WIRING DIAGRAMS**

First pass and carefully dress one output wire from the external CT through the on-board CT (L1). Then connect the ac supply to TB1 as shown. If required, verify that correct line-power polarities are applied to the external load (see Technical Note 4). Ensure all wires are stripped and terminals torqued correctly. For proper operation, pass only a single wire through the on-board CT's center hole.

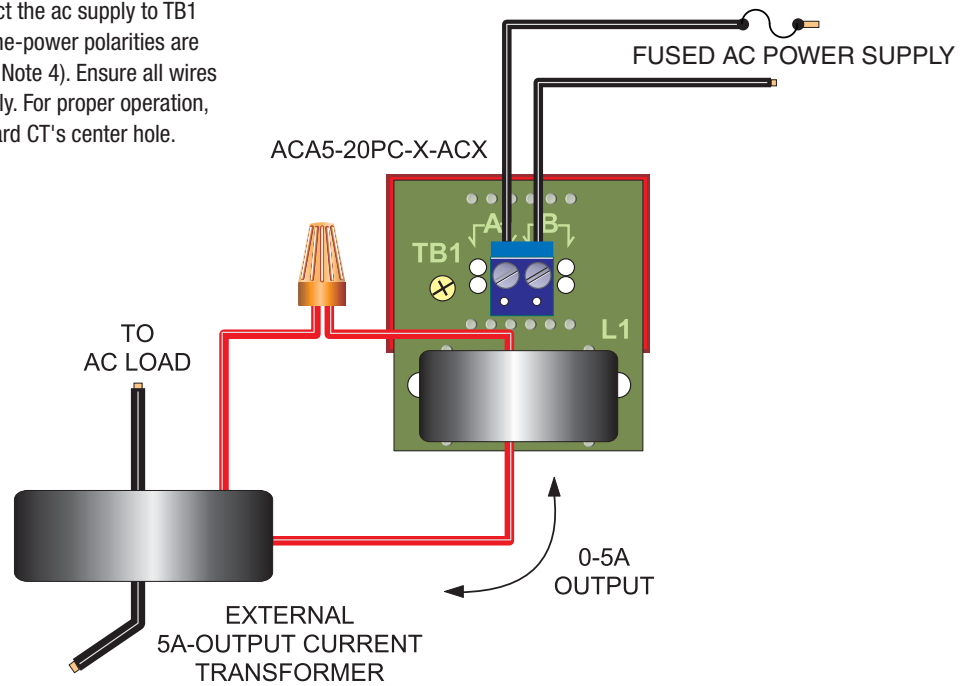

Figure 3. ACA5-20PC AC-Powered Models

First pass and carefully dress one output wire from the external CT through the on-board CT (L1). Then connect the two dc power-supply wires to TB1, observing correct positive ("+") and negative ("-") polarities. Ensure all wires are stripped and terminals torqued correctly. For proper operation, pass only a single wire through the on-board CT's center hole.

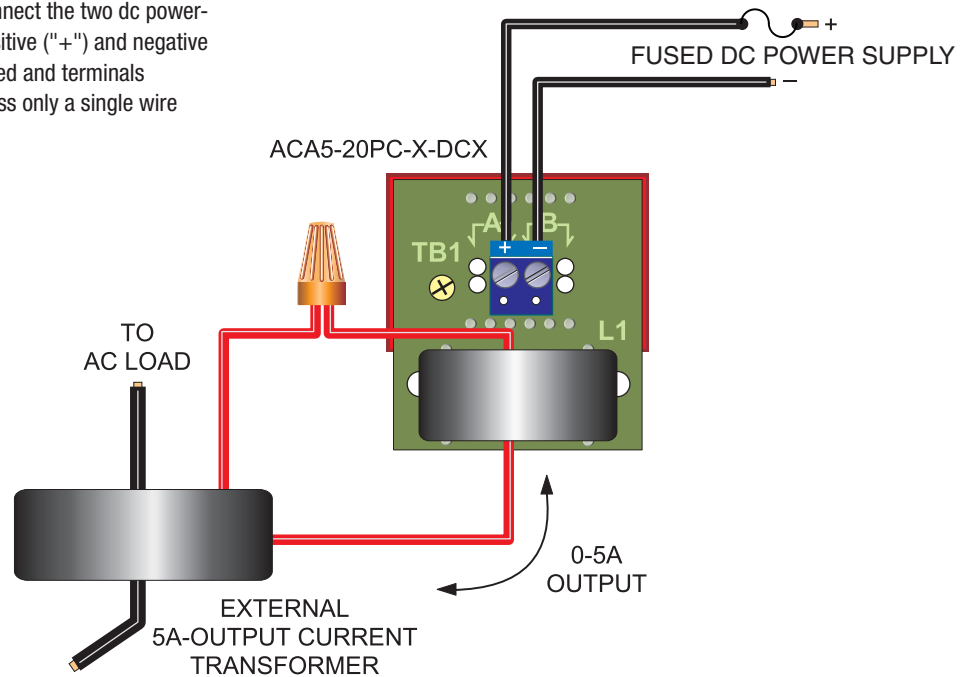
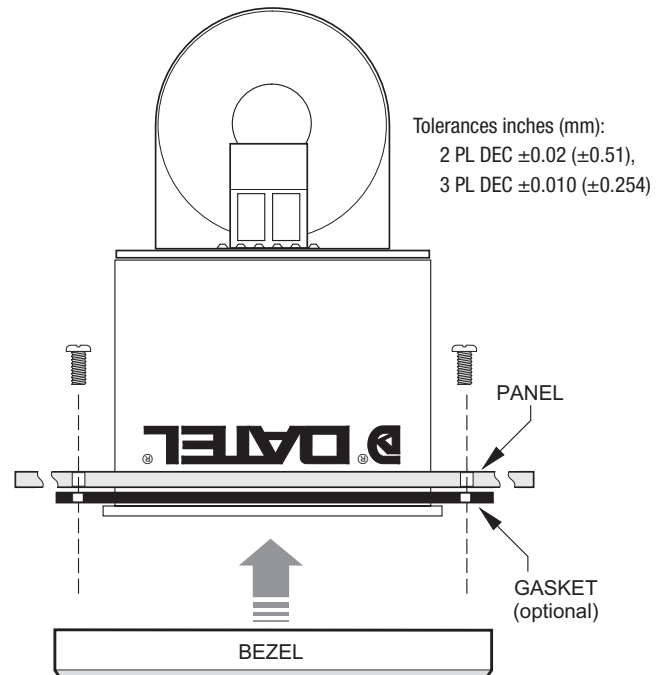
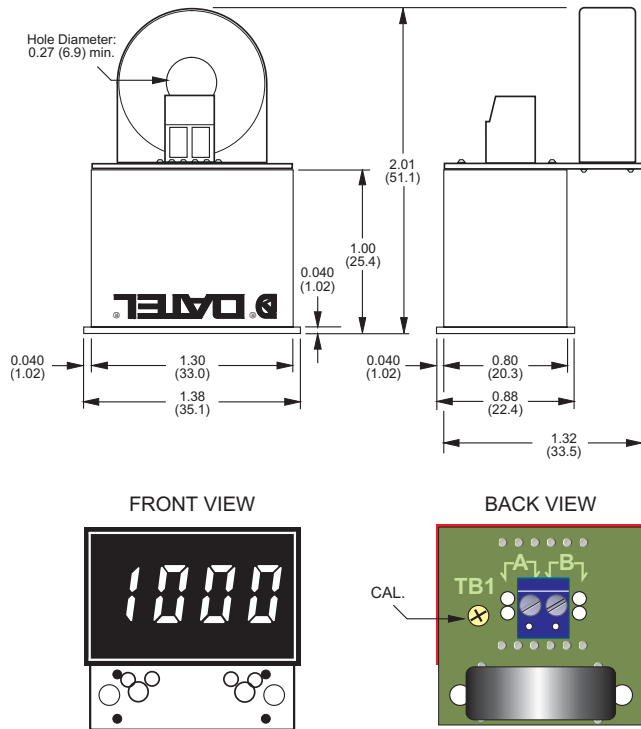
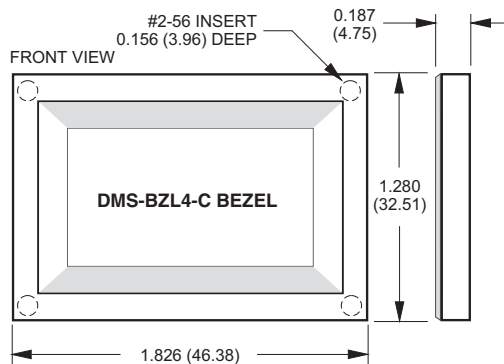

Figure 4. ACA5-20PC DC-Powered Models

**MECHANICAL SPECIFICATIONS**



**BEZEL INSTALLATION AND RECOMMENDED DRILL AND PANEL CUTOUT DIMENSIONS**



**RECOMMENDED DRILL AND PANEL CUTOUT DIMENSIONS**

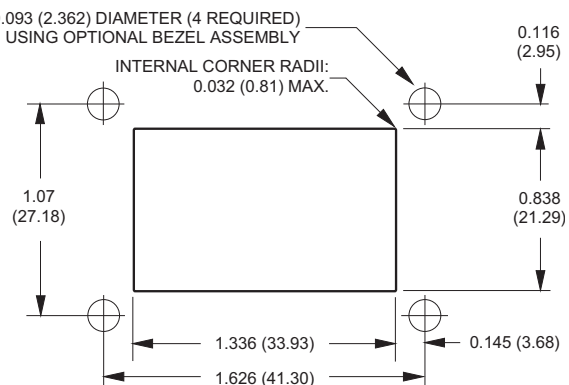



Компания «ЭлектроПласт» предлагает заключение долгосрочных отношений при поставках импортных электронных компонентов на взаимовыгодных условиях!

Наши преимущества:

- Оперативные поставки широкого спектра электронных компонентов отечественного и импортного производства напрямую от производителей и с крупнейших мировых складов;
- Поставка более 17-ти миллионов наименований электронных компонентов;
- Поставка сложных, дефицитных, либо снятых с производства позиций;
- Оперативные сроки поставки под заказ (от 5 рабочих дней);
- Экспресс доставка в любую точку России;
- Техническая поддержка проекта, помощь в подборе аналогов, поставка прототипов;
- Система менеджмента качества сертифицирована по Международному стандарту ISO 9001;
- Лицензия ФСБ на осуществление работ с использованием сведений, составляющих государственную тайну;
- Поставка специализированных компонентов (Xilinx, Altera, Analog Devices, Intersil, Interpoint, Microsemi, Aeroflex, Peregrine, Syfer, Eurofarad, Texas Instrument, Miteq, Cobham, E2V, MA-COM, Hittite, Mini-Circuits, General Dynamics и др.);

Помимо этого, одним из направлений компании «ЭлектроПласт» является направление «Источники питания». Мы предлагаем Вам помощь Конструкторского отдела:

- Подбор оптимального решения, техническое обоснование при выборе компонента;
- Подбор аналогов;
- Консультации по применению компонента;
- Поставка образцов и прототипов;
- Техническая поддержка проекта;
- Защита от снятия компонента с производства.



#### Как с нами связаться

**Телефон:** 8 (812) 309 58 32 (многоканальный)

**Факс:** 8 (812) 320-02-42

**Электронная почта:** [org@eplast1.ru](mailto:org@eplast1.ru)

**Адрес:** 198099, г. Санкт-Петербург, ул. Калинина, дом 2, корпус 4, литера А.