

## Type RQ73 Series

### Key Features

SMD TaN Thin film resistor

Special passivation layer on resistive element

AEC-Q200 qualified

Sulfur resistant (per ASTM B809-95 humid vapor test)

RoHS Compliant



TE Connectivity is proud to introduce this automotive grade thin film precision chip resistor, a sister to our highly successful RN73 range. The resistors are constructed in a high grade raw materials and laser trimmed to give precise tolerance figures. This, coupled with the tight TCR and anti-corrosive protection layer gives us a range of resistors which are ideal not just for automotive applications, but also for medical equipment, measuring instruments and industrial applications.

### Characteristics – Electrical

Type	RQ73 1E	RQ73 1J	RQ73 2A	RQ73 2B
Size	0402	0603	0805	1206
Resistance tolerance	±0.1%			
Resistance Range	40R ~ 35K	40R ~ 130K	10R ~ 350K	10R ~ 1M0
TCR (ppm/°C)	±10PPM/°C			
Max. dissipation at Tamb=85°C	0.0625W	0.15W	0.2W	0.4W
Max. Working Voltage (DC or RMS) <sup>1 2</sup>	50V	75V	100V	200V
Max. Overload Voltage (DC or RMS)	100V	150V	200V	400V
Operating Temperature	-55 ~ 155°C			

Notes:

- This is the maximum voltage that may be continuously supplied to the resistor element, see "IEC publication 60115-8"
- Max. Operation Voltage : So called RCWV (Rated Continuous Working Voltage) determined by

$$RCWV = \sqrt{\text{Rated Power} \times \text{Resistance Value}} \text{ or Max. RCWV listed above, whichever is lower.}$$

### Construction



### Dimensions: (mm)

Type	RQ73 1E	RQ73 1J	RQ73 2A	RQ73 2B
L	1.00 ± 0.10	1.55 ± 0.10	2.00 ± 0.10	3.10 ± 0.10
W	0.50 ± 0.05	0.80 ± 0.10	1.25 ± 0.10	1.60 ± 0.10
A	0.25 ± 0.15	0.3 ± 0.20	0.35 ± 0.20	0.40 ± 0.20
B	0.30 ± 0.10	0.30 ± 0.15	0.40 ± 0.20	0.40 ± 0.20
t	0.30 ± 0.10	0.45 ± 0.15	0.50 ± 0.15	0.60 ± 0.15



### Derating Curve

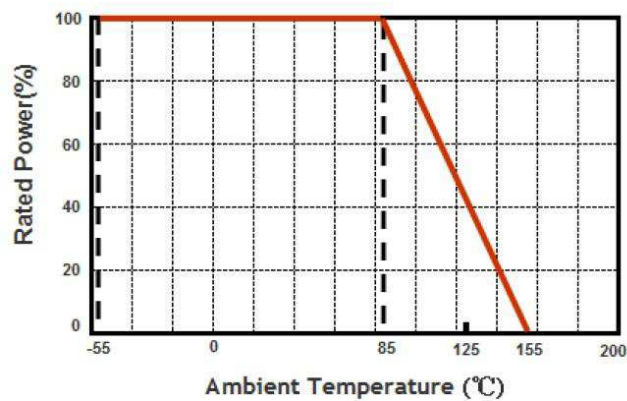

## Environmental Characteristics

Test	Procedure	Requirement
Electrical Characteristics IEC 60115-1 4.8	- DC resistance values measurement - Temperature Coefficient of Resistance (T.C.R) Natural resistance change per change in degree centigrade. $\frac{R_2 - R_1}{R_1(t_2 - t_1)} \times 10^6 \text{ (ppm/}^\circ\text{C)}$ $t_1 : 20^\circ\text{C} \pm 5^\circ\text{C} / -1^\circ\text{C}$ $R_1$ : Resistance at reference temperature ( $20^\circ\text{C} \pm 5^\circ\text{C} / -1^\circ\text{C}$ ) $R_2$ : Resistance at test temperature ( $-55^\circ\text{C}$ or $+125^\circ\text{C}$ )	Within Specified Tolerance
Short time overload (S.T.O.L) IEC60115-1 4.13	Permanent resistance change after a 5 second application of a voltage 2.5 times RCWV or the maximum overload voltage specified in the above list, whichever is less.	$\Delta R/R$ max. $\pm(0.1\%+0.02\Omega)$
Resistance to soldering heat (R.S.H) AEC Q200-15	Un-mounted chips completely immersed for $10 \pm 1$ second in a SAC solder bath at $260^\circ\text{C} \pm 5^\circ\text{C}$	no visible damage $\Delta R/R$ max. $\pm(0.1\%+0.02\Omega)$
Solderability IEC 60068-2-58	Un-mounted chips completely immersed for $2 \pm 0.5$ second in a SAC solder bath at $235^\circ\text{C} \pm 5^\circ\text{C}$	good tinning (>95% covered) no visible damage
Temperature Cycling JESD22 method JA-104	1000 cycles $-55 \sim 125^\circ\text{C}$ , dwell time 5 – 10 min.	no visible damage $\Delta R/R$ max. $\pm(0.1\%+0.02\Omega)$
	1000 cycles $-55 \sim 155^\circ\text{C}$ , dwell time 5 – 10 min.	no visible damage $\Delta R/R$ max. $\pm(0.2\%+0.02\Omega)$
Bias Humidity AEC Q200-7	1000 $+48/-0$ hours, loaded with 10% rated power in humidity chamber controlled at $+85^\circ\text{C} / 85\% \text{RH}$	$\Delta R/R$ max. $\pm(0.1\%+0.02\Omega)$
Load Life IEC60115-1 4.25	1000 $+48/-0$ hours, loaded with RCWV or $V_{\text{max}}$ in chamber controlled at $85 \pm 2^\circ\text{C}$ , 1.5 hours on and 0.5 hours off	$\Delta R/R$ max. $\pm(0.1\%+0.02\Omega)$
Operational Life AEC Q200-8 MIL-STD-202 -108	1,000 hours at $125 \pm 2^\circ\text{C}$ , loaded with rated power continuously	$\Delta R/R$ max. $\pm(0.1\%+0.02\Omega)$
High Temperature Exposure AEC Q200-3	1000 hrs @ $125^\circ\text{C}$ , un-powered	$\Delta R/R$ max. $\pm(0.1\%+0.02\Omega)$
	1000 hrs @ $155^\circ\text{C}$ , un-powered	$\Delta R/R$ max. $\pm(0.15\%+0.02\Omega)$
Moisture Resistance AEC-Q200 -6 MIL-STD-202 Method 106	$65 \pm 2^\circ\text{C}$ , $80 \sim 100\% \text{RH}$ , 10 cycles, 24 hours/ cycle	$\Delta R/R$ max. $\pm(0.1\%+0.02\Omega)$
Mechanical Shock MIL-STD-202 Method 213	1/2 Sine Pulse / 1500g Peak / Velocity 15.4ft/sec	$\Delta R/R$ max. $\pm(0.1\%+0.02\Omega)$
Vibration MIL-STD-202 Method 204	5 g's for 20 min , 12 cycles each of 3 orientations	$\Delta R/R$ max. $\pm(0.1\%+0.02\Omega)$
Terminal strength AEC-Q200-6	1 kg for 60 s	No Physical Damage
Board flex AEC-Q200-21	Bending 2mm for 60 sec	$\Delta R/R$ max. $\pm(0.1\%+0.02\Omega)$
Flower of sulfur test ASTM B809 - 95	$105 \pm 2^\circ\text{C}$ , Duration 1,000 hours	0402 $\Delta R/R$ max. $\pm(0.2\%+0.02\Omega)$ Others $\Delta R/R$ max. $\pm(0.1\%+0.02\Omega)$

## Marking:

**0603** E24 series 3 Digits – first two digits denote significant figures of resistance and third digit denotes number of zeros thereafter. EG

	222	
--	-----	--

 = 
 2K2

**0603** E96 series 3 Digits - The 1st two digit codes are referring to the CODE in the table, the 3rd code is the index of resistance value :

$Y=10^{-2}$ ,  $X=10^{-1}$ ,  $A=10^0$ ,  $B=10^1$ ,  $C=10^2$ ,  $D=10^3$ ,  $E=10^4$ ,  $F=10^5$

EX :  $17.8\Omega=25X$ ,  $178\Omega=25A$ ,  $1K78 =25B$

$17K8=25C$ ,  $178K=25D$ ,  $1M78=25E$

CODE	R_value	CODE	R_value	CODE	R_value	CODE	R_value	CODE	R_value	CODE	R_value	CODE	R_value	CODE	R_value
01	100	13	133	25	178	37	237	49	316	61	422	73	562	85	750
02	102	14	137	26	182	38	243	50	324	62	432	74	576	86	768
03	105	15	140	27	187	39	249	51	332	63	442	75	590	87	787
04	107	16	143	28	191	40	255	52	340	64	453	76	604	88	806
05	110	17	147	29	196	41	261	53	348	65	464	77	619	89	825
06	113	18	150	30	200	42	267	54	357	66	475	78	634	90	845
07	115	19	154	31	205	43	274	55	365	67	487	79	649	91	866
08	118	20	158	32	210	44	280	56	374	68	499	80	665	92	887
09	121	21	162	33	215	45	287	57	383	69	511	81	681	93	909
10	124	22	165	34	221	46	294	58	392	70	523	82	698	94	931
11	127	23	169	35	226	47	301	59	402	71	536	83	715	95	953
12	130	24	174	36	232	48	309	60	412	72	549	84	732	96	976

0805 & 1206 E24 and E96 4 digits – Where value is below 100R use R as decimal, otherwise three significant figures plus number of following zeros.

E.G.

Resistance	10 $\Omega$	12 $\Omega$	100 $\Omega$	6K8	47K
4 digit marking	10R0	12R0	1000	6801	4702

Notes:

1. No marking for non-E24/E96 resistance values.
2. No marking for 0402 size resistors

## Packaging

### Paper Tape Specification (mm)

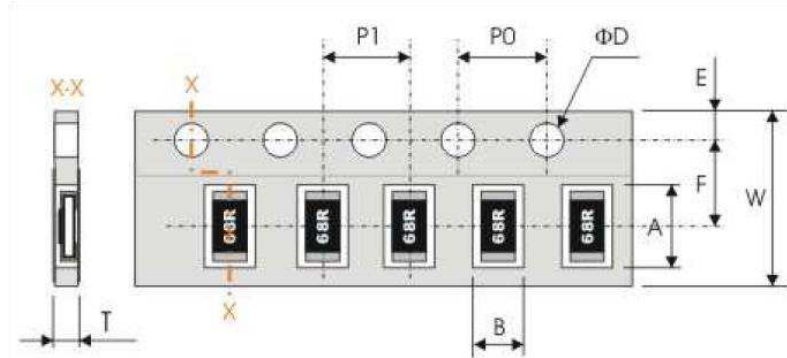

Size	A	B	W	F	E
0402	1.20±0.10	0.7±0.10	8.00±0.30	3.50±0.05	1.75±0.10
0603	1.90±0.20	1.10±0.20	8.00±0.30	3.50±0.20	1.75±0.10
0805	2.40±0.20	1.65±0.20	8.00±0.30	3.50±0.20	1.75±0.10
1206	3.60±0.20	2.00±0.20	8.00±0.30	3.50±0.20	1.75±0.10

Size	P1	P0	ØD	T
0402	2.00±0.10	4.00±0.10	Ø1.50 <sup>+0.1</sup> <sub>-0.0</sub>	0.40±0.05
0603	4.00±0.10	4.00±0.10	Ø1.50 <sup>+0.1</sup> <sub>-0.0</sub>	0.65±0.05
0805	4.00±0.10	4.00±0.10	Ø1.50 <sup>+0.1</sup> <sub>-0.0</sub>	Max. 1.0
1206	4.00±0.10	4.00±0.10	Ø1.50 <sup>+0.1</sup> <sub>-0.0</sub>	Max. 1.0

### Reel Dimensions (mm)

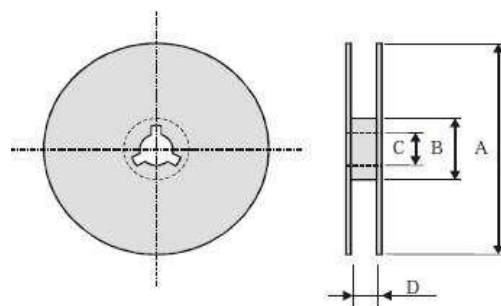

Symbol	A	B	C	D
Dim. (mm)	Ø178.0±2.0	Ø60.0±1.0	13.0±0.2	9.0±0.5

All sizes 5,000 pieces per reel

## Storage and Handling Condition:

1. Products are recommended to be used up within two years. Check solderability in case shelf life extension is needed.
2. To store products with following condition:  
Temperature : 5 to 40°C  
Humidity : 20 to 70% relative humidity
3. Caution:
  - a. Don't store products in a corrosive environment such as sulfide, chloride gas, or acid. It may cause oxidation of electrode, which easily be resulted in poor soldering.
  - b. To store products on the shelf and avoid exposure to moisture.
  - c. Don't expose products to excessive shock, vibration, direct sunlight etc.

## MOUNTING

Due to their rectangular shapes and small tolerances, Surface Mountable Resistors are suitable for handling by automatic placement systems.

Chip placement can be on ceramic substrates and printed-circuit boards (PCBs).

Electrical connection to the circuit is by individual soldering condition.

The end terminations guarantee a reliable contact.

## SOLDERING CONDITION

The robust construction of chip resistors allows them to be completely immersed in a solder bath of 260°C for 10 seconds. Therefore, it is possible to mount Surface Mount Resistors on one side of a PCB and other discrete components on the reverse (mixed PCBs).

Surface Mount Resistors are tested for solderability at 235°C during 2 seconds within lead-free solder bath. The test condition for no leaching is 260°C for 30 seconds.

Typical examples of soldering profile and condition that provide reliable joints without any damage are given below.

### Infrared soldering condition for Chip Resistors

Temperature Condition	Exposure time
Average ramp-up rate (217°C to 260°C)	Less than 3°C/second
Between 150 and 200°C	Between 60-120 seconds
> 217°C	Between 60-150 seconds
Peak Temperature	260°C +0/-5°C
Time within 245°C	Min. 30 seconds
Ramp-down rate (Peak to 217°C)	Less than 6°C/second
Time from 25°C to Peak	No greater than 480 seconds

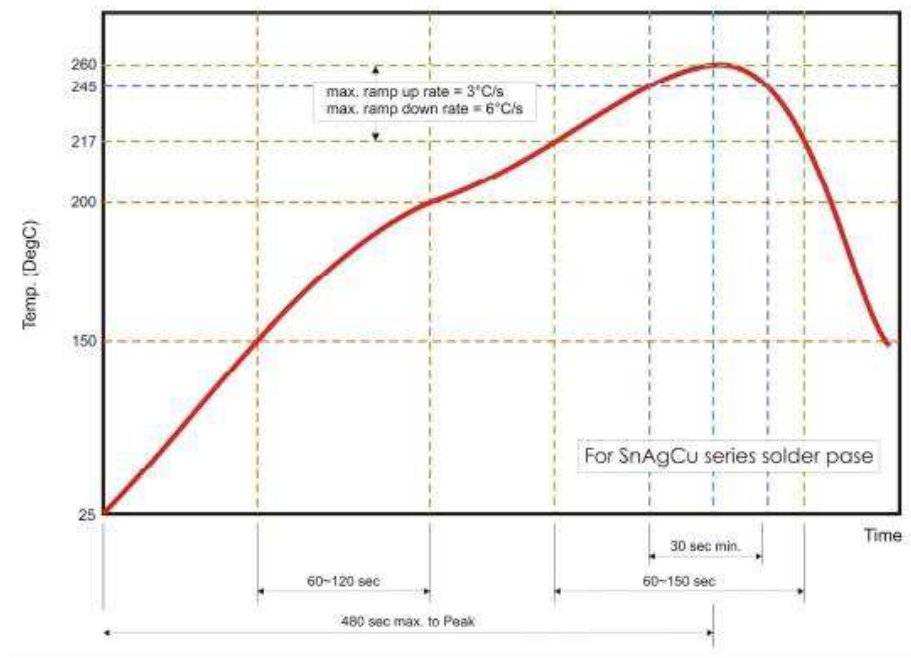

Infrared soldering profile for Chip Resistors

How To Order

**RQ73      C                      1E                      40R2                      B                      TDF**

Common Part	TCR	Size Code	Resistance Value	Tolerance	Packaging Spec.
RQ73	C = 10PPM/°C	1E = 0402 1J = 0603 2A = 0805 2B = 1206	100R (100Ω) 1K0 (1000Ω) 100K (100,000Ω)	B = .1%	TD = Reel 5000 TDF = Reel 1000



Компания «ЭлектроПласт» предлагает заключение долгосрочных отношений при поставках импортных электронных компонентов на взаимовыгодных условиях!

Наши преимущества:

- Оперативные поставки широкого спектра электронных компонентов отечественного и импортного производства напрямую от производителей и с крупнейших мировых складов;
- Поставка более 17-ти миллионов наименований электронных компонентов;
- Поставка сложных, дефицитных, либо снятых с производства позиций;
- Оперативные сроки поставки под заказ (от 5 рабочих дней);
- Экспресс доставка в любую точку России;
- Техническая поддержка проекта, помощь в подборе аналогов, поставка прототипов;
- Система менеджмента качества сертифицирована по Международному стандарту ISO 9001;
- Лицензия ФСБ на осуществление работ с использованием сведений, составляющих государственную тайну;
- Поставка специализированных компонентов (Xilinx, Altera, Analog Devices, Intersil, Interpoint, Microsemi, Aeroflex, Peregrine, Syfer, Eurofarad, Texas Instrument, Miteq, Cobham, E2V, MA-COM, Hittite, Mini-Circuits, General Dynamics и др.);

Помимо этого, одним из направлений компании «ЭлектроПласт» является направление «Источники питания». Мы предлагаем Вам помощь Конструкторского отдела:

- Подбор оптимального решения, техническое обоснование при выборе компонента;
- Подбор аналогов;
- Консультации по применению компонента;
- Поставка образцов и прототипов;
- Техническая поддержка проекта;
- Защита от снятия компонента с производства.



#### Как с нами связаться

**Телефон:** 8 (812) 309 58 32 (многоканальный)

**Факс:** 8 (812) 320-02-42

**Электронная почта:** [org@eplast1.ru](mailto:org@eplast1.ru)

**Адрес:** 198099, г. Санкт-Петербург, ул. Калинина, дом 2, корпус 4, литера А.