



MCP9700 Thermistor Demo Board User's Guide

Note the following details of the code protection feature on Microchip devices:

- Microchip products meet the specification contained in their particular Microchip Data Sheet.
- Microchip believes that its family of products is one of the most secure families of its kind on the market today, when used in the intended manner and under normal conditions.
- There are dishonest and possibly illegal methods used to breach the code protection feature. All of these methods, to our knowledge, require using the Microchip products in a manner outside the operating specifications contained in Microchip's Data Sheets. Most likely, the person doing so is engaged in theft of intellectual property.
- Microchip is willing to work with the customer who is concerned about the integrity of their code.
- Neither Microchip nor any other semiconductor manufacturer can guarantee the security of their code. Code protection does not mean that we are guaranteeing the product as "unbreakable."

Code protection is constantly evolving. We at Microchip are committed to continuously improving the code protection features of our products. Attempts to break Microchip's code protection feature may be a violation of the Digital Millennium Copyright Act. If such acts allow unauthorized access to your software or other copyrighted work, you may have a right to sue for relief under that Act.

Information contained in this publication regarding device applications and the like is provided only for your convenience and may be superseded by updates. It is your responsibility to ensure that your application meets with your specifications. MICROCHIP MAKES NO REPRESENTATIONS OR WARRANTIES OF ANY KIND WHETHER EXPRESS OR IMPLIED, WRITTEN OR ORAL, STATUTORY OR OTHERWISE, RELATED TO THE INFORMATION, INCLUDING BUT NOT LIMITED TO ITS CONDITION, QUALITY, PERFORMANCE, MERCHANTABILITY OR FITNESS FOR PURPOSE. Microchip disclaims all liability arising from this information and its use. Use of Microchip devices in life support and/or safety applications is entirely at the buyer's risk, and the buyer agrees to defend, indemnify and hold harmless Microchip from any and all damages, claims, suits, or expenses resulting from such use. No licenses are conveyed, implicitly or otherwise, under any Microchip intellectual property rights.

Trademarks

The Microchip name and logo, the Microchip logo, Accuron, dsPIC, KEELOQ, KEELOQ logo, MPLAB, PIC, PICmicro, PICSTART, rPIC and SmartShunt are registered trademarks of Microchip Technology Incorporated in the U.S.A. and other countries.

FilterLab, Linear Active Thermistor, MXDEV, MXLAB, SEEVAL, SmartSensor and The Embedded Control Solutions Company are registered trademarks of Microchip Technology Incorporated in the U.S.A.

Analog-for-the-Digital Age, Application Maestro, CodeGuard, dsPICDEM, dsPICDEM.net, dsPICworks, dsSPEAK, ECAN, ECONOMONITOR, FanSense, In-Circuit Serial Programming, ICSP, ICEPIC, Mindi, MiWi, MPASM, MPLAB Certified logo, MPLIB, MPLINK, mTouch, PICkit, PICDEM, PICDEM.net, PICTail, PIC³² logo, PowerCal, PowerInfo, PowerMate, PowerTool, REAL ICE, rLAB, Select Mode, Total Endurance, UNI/O, WiperLock and ZENA are trademarks of Microchip Technology Incorporated in the U.S.A. and other countries.

SQTP is a service mark of Microchip Technology Incorporated in the U.S.A.

All other trademarks mentioned herein are property of their respective companies.

© 2008, Microchip Technology Incorporated, Printed in the U.S.A., All Rights Reserved.

 Printed on recycled paper.

QUALITY MANAGEMENT SYSTEM
CERTIFIED BY DNV
== ISO/TS 16949:2002 ==

Microchip received ISO/TS-16949:2002 certification for its worldwide headquarters, design and wafer fabrication facilities in Chandler and Tempe, Arizona; Gresham, Oregon and design centers in California and India. The Company's quality system processes and procedures are for its PIC[®] MCUs and dsPIC[®] DSCs, KEELOQ[®] code hopping devices, Serial EEPROMs, microperipherals, nonvolatile memory and analog products. In addition, Microchip's quality system for the design and manufacture of development systems is ISO 9001:2000 certified.



MCP9700 THERMISTOR DEMO BOARD USER'S GUIDE

Table of Contents

Preface	1
Introduction.....	1
Document Layout	1
Conventions Used in this Guide	2
Recommended Reading.....	3
The Microchip Web Site	3
Customer Support	3
Document Revision History	4
Chapter 1. Product Overview	
1.1 Introduction	5
1.2 What is the MCP9700 Thermistor Demo Board?	5
1.3 What the MCP9700 Thermistor Demo Board Kit Includes	5
Chapter 2. Installation and Operation	
2.1 Introduction	7
2.2 Getting Started	7
2.3 Configuring Board	9
Appendix A. Schematic and Layouts	
A.1 Introduction	13
A.2 Board Schematic - Page 1	14
A.3 Board - Top Silk-screen Layer	15
A.4 Board - Top Layer	15
A.5 Board - Bottom Silk	16
A.6 Board - Bottom Layer	16
Appendix B. Bill Of Materials (BOM)	
Worldwide Sales and Service	20

MCP9700 Thermistor Demo Board User's Guide

NOTES:

Preface

NOTICE TO CUSTOMERS

All documentation becomes dated, and this manual is no exception. Microchip tools and documentation are constantly evolving to meet customer needs, so some actual dialogs and/or tool descriptions may differ from those in this document. Please refer to our web site (www.microchip.com) to obtain the latest documentation available.

Documents are identified with a “DS” number. This number is located on the bottom of each page, in front of the page number. The numbering convention for the DS number is “DSXXXXA”, where “XXXX” is the document number and “A” is the revision level of the document.

For the most up-to-date information on development tools, see the MPLAB® IDE on-line help. Select the Help menu, and then Topics to open a list of available on-line help files.

INTRODUCTION

This chapter contains general information that will be useful to know before using the MCP9700 Thermistor Demo Board. Items discussed in this chapter include:

- Document Layout
- Conventions Used in this Guide
- Recommended Reading
- The Microchip Web Site
- Customer Support
- Document Revision History

DOCUMENT LAYOUT

This document describes how to use the MCP9700 Thermistor Demo Board as a development tool. The manual layout is as follows:

- **Chapter 1. “Product Overview”** – Important information about the MCP9700 Thermistor Demo Board.
- **Chapter 2. “Installation and Operation”** – This chapter includes a detailed description of each function of the demo board and instructions for how to begin using the board.
- **Appendix A. “Schematic and Layouts”** – Shows the schematic and layout diagrams for the MCP9700 Thermistor Demo Board.
- **Appendix B. “Bill Of Materials (BOM)”** – Lists the parts used to build the MCP9700 Thermistor Demo Board.

MCP9700 Thermistor Demo Board User's Guide

CONVENTIONS USED IN THIS GUIDE

This manual uses the following documentation conventions:

DOCUMENTATION CONVENTIONS

Description	Represents	Examples
Arial font:		
Italic characters	Referenced books	<i>MPLAB[®] IDE User's Guide</i>
	Emphasized text	...is the <i>only</i> compiler...
Initial caps	A window	the Output window
	A dialog	the Settings dialog
	A menu selection	select Enable Programmer
Quotes	A field name in a window or dialog	"Save project before build"
Underlined, italic text with right angle bracket	A menu path	<u><i>File>Save</i></u>
Bold characters	A dialog button	Click OK
	A tab	Click the Power tab
N'Rnnnn	A number in verilog format, where N is the total number of digits, R is the radix and n is a digit.	4'b0010, 2'hF1
Text in angle brackets < >	A key on the keyboard	Press <Enter>, <F1>
Courier New font:		
Plain Courier New	Sample source code	#define START
	Filenames	autoexec.bat
	File paths	c:\mcc18\h
	Keywords	_asm, _endasm, static
	Command-line options	-Opa+, -Opa-
	Bit values	0, 1
	Constants	0xFF, 'A'
Italic Courier New	A variable argument	<i>file.o</i> , where <i>file</i> can be any valid filename
Square brackets []	Optional arguments	mcc18 [options] <i>file</i> [options]
Curly brackets and pipe character: { }	Choice of mutually exclusive arguments; an OR selection	errorlevel {0 1}
Ellipses...	Replaces repeated text	var_name [, var_name...]
	Represents code supplied by user	void main (void) { ... }

RECOMMENDED READING

This user's guide describes how to use the MCP9700 Thermistor Demo Board. The following Microchip documents are available on our web site (www.microchip.com) and recommended as supplemental reference resources.

AN897, “Thermistor Temperature Sensing with MCP6SX2 PGAs”, DS00897

Explains the functionality and design of this board's circuit. Contains measurement results.

MCP9700 Data Sheet, “Low-Power Linear Active Thermistor™”, DS21942

This data sheet provides detailed information regarding the MCP9700 product family.

MCP6S21/2/6/8 Data Sheet, “Single-Ended, Rail-to-Rail I/O, Low Gain PGA”, DS21117

Gives detailed information on the MCP6S21/2/3/6/8 Programmable Gain Amplifiers (PGA).

MCP6S91/2/3 Data Sheet, “Single-Ended, Rail-to-Rail I/O, Low Gain PGA”, DS21908

Gives detailed information on the MCP6S91/2/3 PGAs.

PIC18F2455/2550/4455/4550 Data Sheet, “28/40/44-Pin, High-Performance, Enhanced Flash, USB Microcontrollers with nanoWatt Technology”, DS39632

This data sheet provides detailed information regarding the PIC18F2455/2550/4455/4550 devices.

THE MICROCHIP WEB SITE

Microchip provides online support via our web site at www.microchip.com. This web site is used as a means to make files and information easily available to customers. Accessible by using your favorite internet browser, the web site contains the following information:

- **Product Support** – Data sheets and errata, application notes and sample programs, design resources, user's guides and hardware support documents, latest software releases and archived software
- **General Technical Support** – Frequently Asked Questions (FAQs), technical support requests, online discussion groups, Microchip consultant program member listing
- **Business of Microchip** – Product selector and ordering guides, latest Microchip press releases, listing of seminars and events, listings of Microchip sales offices, distributors and factory representatives

CUSTOMER SUPPORT

Users of Microchip products can receive assistance through several channels:

- Distributor or Representative
- Local Sales Office
- Field Application Engineer (FAE)
- Technical Support
- Development Systems Information Line

Customers should contact their distributor, representative or field application engineer for support. Local sales offices are also available to help customers. A listing of sales offices and locations is included in the back of this document.

Technical support is available through the web site at: <http://support.microchip.com>

DOCUMENT REVISION HISTORY

Revision A (August 2008)

- Initial Release of this Document

Chapter 1. Product Overview

1.1 INTRODUCTION

The following name and assembly number are found on the MCP9700 Thermistor Demo Board's Printed Circuit Board (PCB):

- 102-00156

This PCB goes by the following title:

- MCP9700 Thermistor Demo Board

This board is supported by AN897, "*Thermistor Temperature-Sensing with MCP6SX2 PGAs*", (DS00897). It uses a BC Components® 2322 640 55103 NTC thermistor to detect temperature. The circuit also includes a voltage divider and a MCP6S22 Programmable Gain Amplifier (PGA) and the MCP9700 Linear Active Thermistor.

- Kit Contents
- MCP9700 Thermistor Demo Board
- Associated Tools
- Initial Set-up

1.2 WHAT IS THE MCP9700 THERMISTOR DEMO BOARD?

The MCP9700 Thermistor Demo Board contains the analog circuitry to measure temperature. It uses BC Components' 2322 640 55103 NTC thermistor to convert temperature to resistance. The thermistor is placed in a voltage divider which converts resistance to voltage. This voltage is filtered and placed at the MCP6S22 Programmable Gain Amplifier's (PGA) CH0 input. The PGA gains and buffers the thermistor.

In addition, the board includes the MCP9700 Linear Active Thermistor. The MCP9700 outputs voltage proportional to temperature. A PIC18F2550 is used to both measure the voltage output of the MCP9700 and the MCP6S22 using an integrated 10-bit Analog to Digital Converter and communicate to a PC via USB interface.

Temperature can be datalogged using Microchip Thermal Management Software Graphical User Interface (GUI).

1.3 WHAT THE MCP9700 THERMISTOR DEMO BOARD KIT INCLUDES

- MCP9700 Thermistor Demo Board – An assembled and tested PCB (102-00156)
- Microchip Thermal Management Graphical User Interface
- Analog and Interface Products Demonstration Boards CD-ROM (DS21912)
 - MCP9700 Thermistor Demo Board User's Guide, (DS51753)

MCP9700 Thermistor Demo Board User's Guide

NOTES:

Chapter 2. Installation and Operation

2.1 INTRODUCTION

The MCP9700 Thermistor Demo Board makes it easy to explore the operation of two thermistor applications using the MCP6S22 PGA and the MCP9700 Linear Active Thermistor. Items discussed in this chapter include:

- Configuring the MCP9700 Thermistor Demo Board
- Using the MCP9700 Thermistor Demo Board
- Using the Microchip Thermal Management GUI

2.2 GETTING STARTED

This section describes how to power up and interface with the MCP9700 Thermistor Demo Board, [Figure 2-1](#).

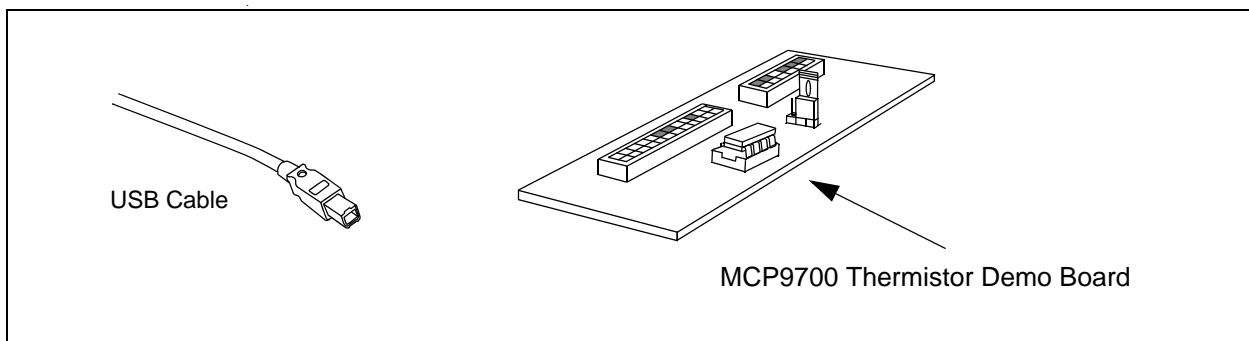

FIGURE 2-1: MCP9700 Thermistor Demo Board Block Diagram.

2.2.1 Hardware Setup

1. The MCP9700 Thermistor Demo Board has a mini-USB connector for a PC interface. Connect the USB cable from the MCP9700 Thermistor Demo Board to a PC. The MCP9700 Thermistor Demo Board is fully powered and temperature can be measured.
2. Start the Thermal Management Software GUI for data logging or to evaluate the MCP9700 Thermistor Demo Board features.

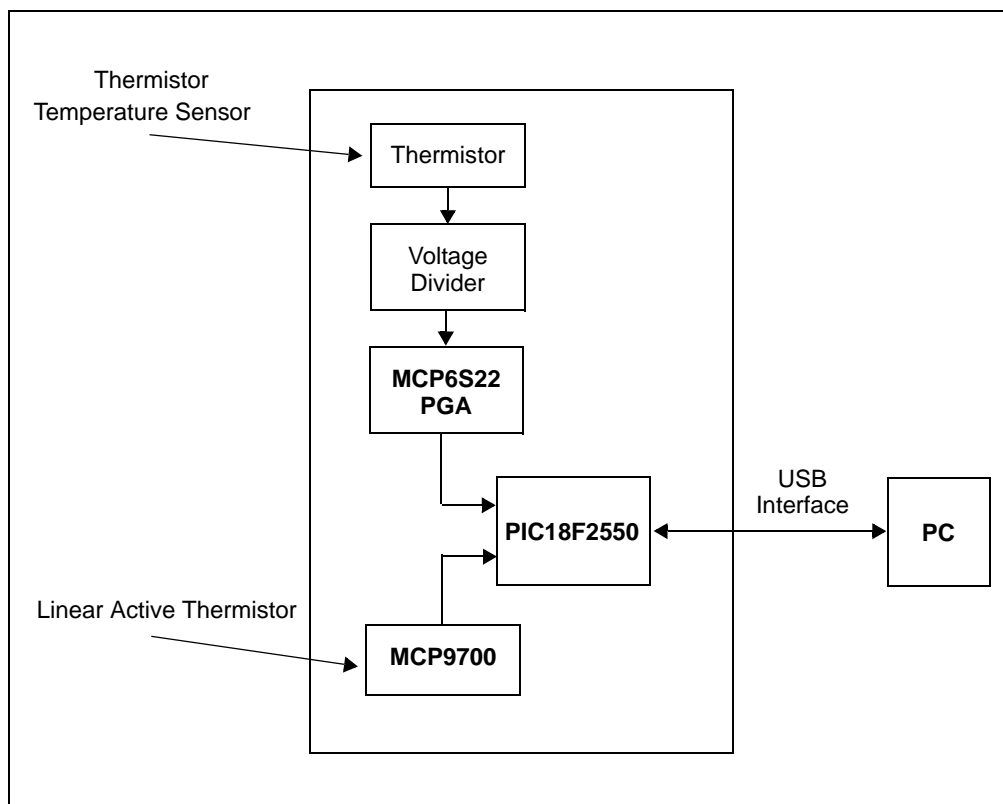

FIGURE 2-2: MCP9700 Thermistor Demo Board Circuit Block Diagram.

The MCP9700 Thermistor Demo Board includes a Thermistor and Microchip's MCP9700 Linear Active Thermistor temperature sensors. The thermistor is biased using a resistive stack which can be adjusted using the user settable dip switches. The voltage across the thermistor is proportional to change in temperature. The thermistor output is gained and buffered using Microchip's MCP6S22 Programmable Gain Amplifier (PGA). The output of the PGA is directly connected to an Analog to Digital Converter. The MCP9700 output voltage is also directly connected to an ADC. The data from the ADC is sent to the PC using the USB interface.

The user can compare and evaluate both the standard thermistor solution and Microchip's Linear Active Thermistor solution using this MCP9700 Thermistor Demo Board.

2.3 CONFIGURING BOARD

2.3.1 Configuring Jumper JMP1 (select Thermistor or Rvar)

Figure 2-3 shows how jumper JMP1 configures the circuit. When the shorting bar is on the right side of jumper JMP1, the thermistor R_{TH} is connected to the circuit. When it is on the left side of jumper JMP1, the thermistor emulator R_{var} is connected to the circuit. Refer to Figure A.3 for the complete schematic.

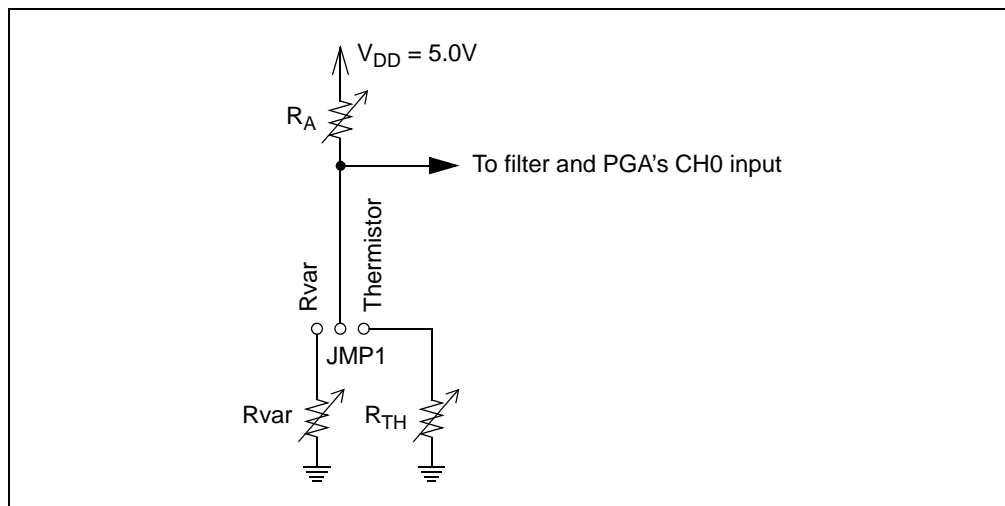

FIGURE 2-3: Simplified Jumper Circuit.

2.3.2 Configuring DIP Switch SW1 (R_A)

DIP switch SW_1 and resistors $R_1 - R_7$ in Figure 2-4 emulate the voltage divider resistor (R_A in Figure 2-3). R_1 is placed in series with the others to prevent shorting the supplies together. These resistors produce a binary sequence of values between $0.5\text{ k}\Omega$ and $32.0\text{ k}\Omega$.

Refer to Figure A.3 for the complete schematic.

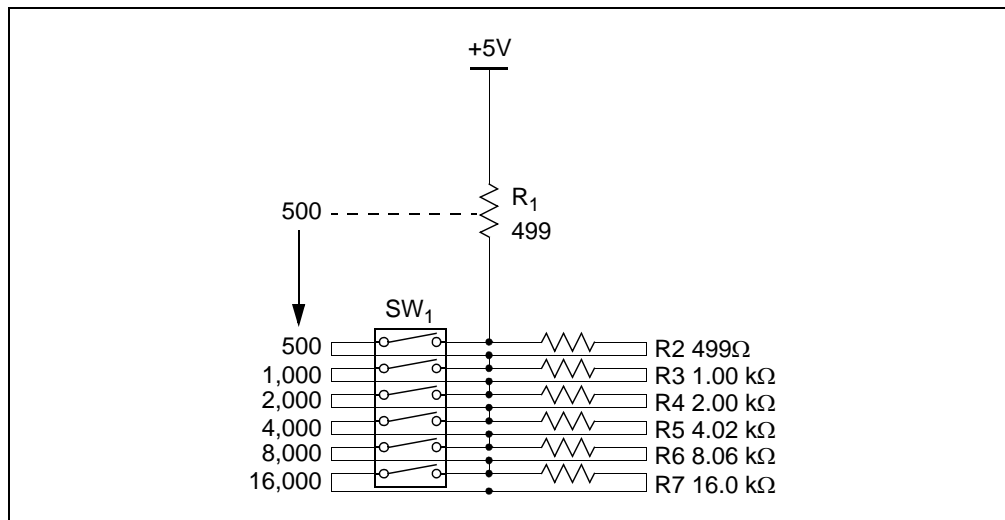

FIGURE 2-4: R_A Emulator.

Each resistor with its switch (in SW1) pointing to the right, away from the silk screen resistor values, is not added into the total for R_A (it shorts that resistor).

Each resistor with its switch (in SW1) pointing to the left, towards the silk screen resistor values, is added into the total for R_A .

As an example, if the top four switches are to the right, and the bottom two are to the left, then R_A is calculated as $500 + 0 + 0 + 0 + 0 + 8,000 + 16,000 = 24,500\Omega$.

2.3.3 Using the Thermistor (R_{TH})

In **Appendix A. "Schematic and Layouts"**, R_{21} is the thermistor (R_{TH} in [Figure 2-3](#)). The resistance changes depending on temperature; see AN897, "Thermistor Temperature Sensing with MCP6SX2 PGAs" (DS00897).

2.3.4 Configuring DIP Switch SW2 (R_{TH} Emulator, R_{var})

DIP switch SW2 and resistors $R_8 - R_{19}$ in [Figure 2-5](#) comprise the thermistor emulator (R_{var} in [Figure 2-3](#)). R_{var} produces a binary sequence of resistances between 0Ω and $409.5\text{ k}\Omega$.

Refer to [Figure A.3](#) for the complete schematic.

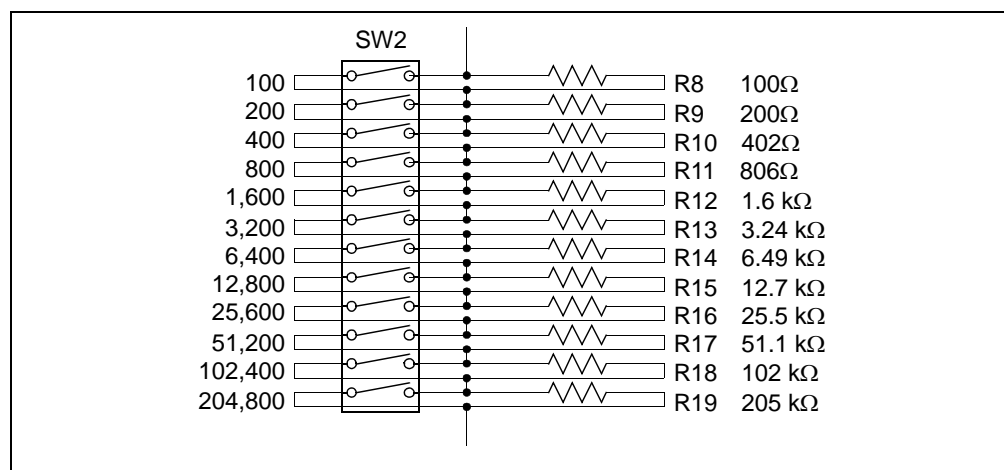

FIGURE 2-5: R_{TH} Emulator (R_{var}).

Each resistor with its switch (in SW2) pointing to the right, away from the silk screen resistor values, is not added into the total for R_A (it shorts that resistor).

Each resistor with its switch (in SW) pointing to the left, towards the silk screen resistor values, is added into the total for R_A .

As an example, if the top ten switches are to the right, and the bottom two are to the left, then R_{var} is calculated as $0 + 0 + \dots + 0 + 102,400 + 204,800 = 307,200\Omega$.

AN897, "Thermistor Temperature Sensing with MCP6SX2 PGAs" (DS00897) contains information on converting this resistance to the equivalent, nominal thermistor temperature, and vice versa.

2.3.5 Using the MCP9700

The MCP9700 Linear Active Thermistor is a temperature sensor which outputs voltage directly proportional to change in temperature. This sensor provides a 10 mV per degree Celsius temperature coefficient and it measures temperature from -40°C to $+125^{\circ}\text{C}$, see datasheet (DS21942) for details.

2.3.6 Microchip Thermal Management GUI

The Microchip Thermal Management Graphical User Interface is an easy to use software tool which allows users to evaluate the MCP9700 Thermistor Demo Board and sensor features, as displayed in [Figure 2-6](#).

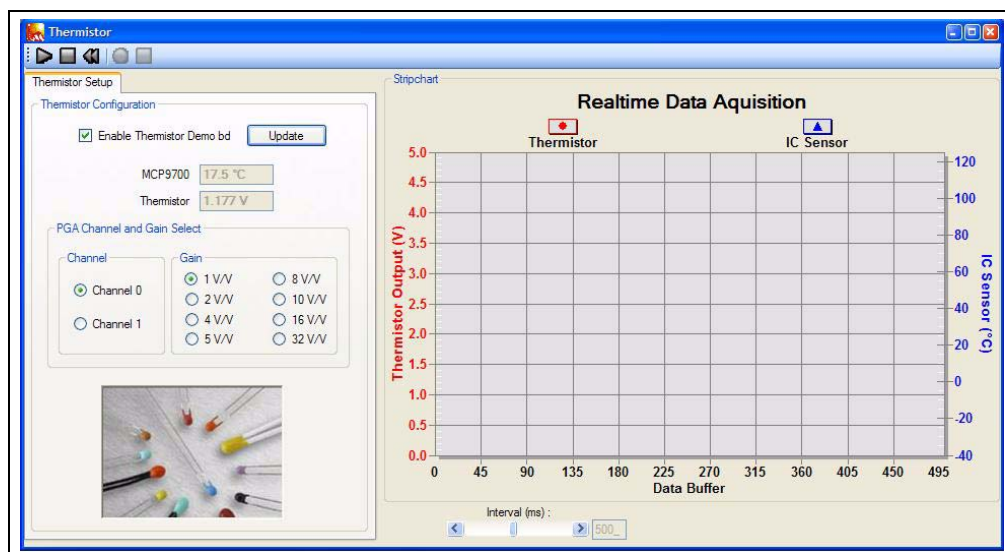

FIGURE 2-6: Microchip Thermal Management GUI.

Once the hardware is connected, the software recognizes the device ID and displays the corresponding GUI for the MCP9700 Thermistor Demo Board. This tool enables the user to evaluate the demo board features and perform temperature datalog. The black “Play”, “Stop”, and “Reset” icons can be used to perform continuous datalog. And the red “Record” icon enables the user to datalog to an external file. The logging interval can be adjusted using the Interval Scroll bar from 100 ms to 1000 ms.

The Real-time Data Acquisition charting tool can be customized by double clicking the chart, as shown in [Figure 2-7](#). Additional options are available by right clicking the chart. The users can also zoom into a specific plot range by clicking and dragging the section.

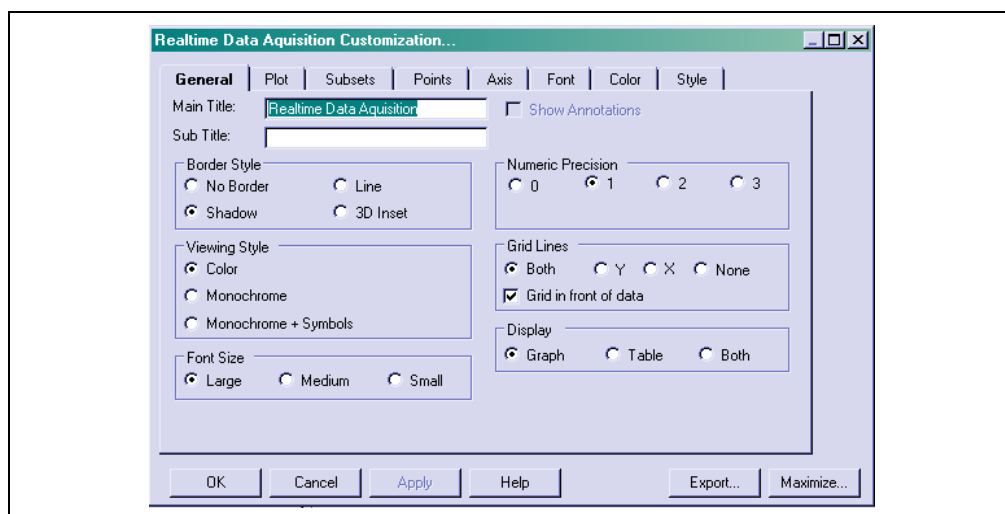

FIGURE 2-7: Chart Setup Options.

MCP9700 Thermistor Demo Board User's Guide

NOTES:



MCP9700 THERMISTOR DEMO BOARD USER'S GUIDE

Appendix A. Schematic and Layouts

A.1 INTRODUCTION

This appendix contains the following schematics and layouts for the MCP9700 Thermistor Demo Board:

- Board Schematic
- Board - Top Layer
- Board - Silk-screen Layer
- Board - Bottom Layer

MCP9700 Thermistor Demo Board User's Guide

A.2 BOARD SCHEMATIC - PAGE 1

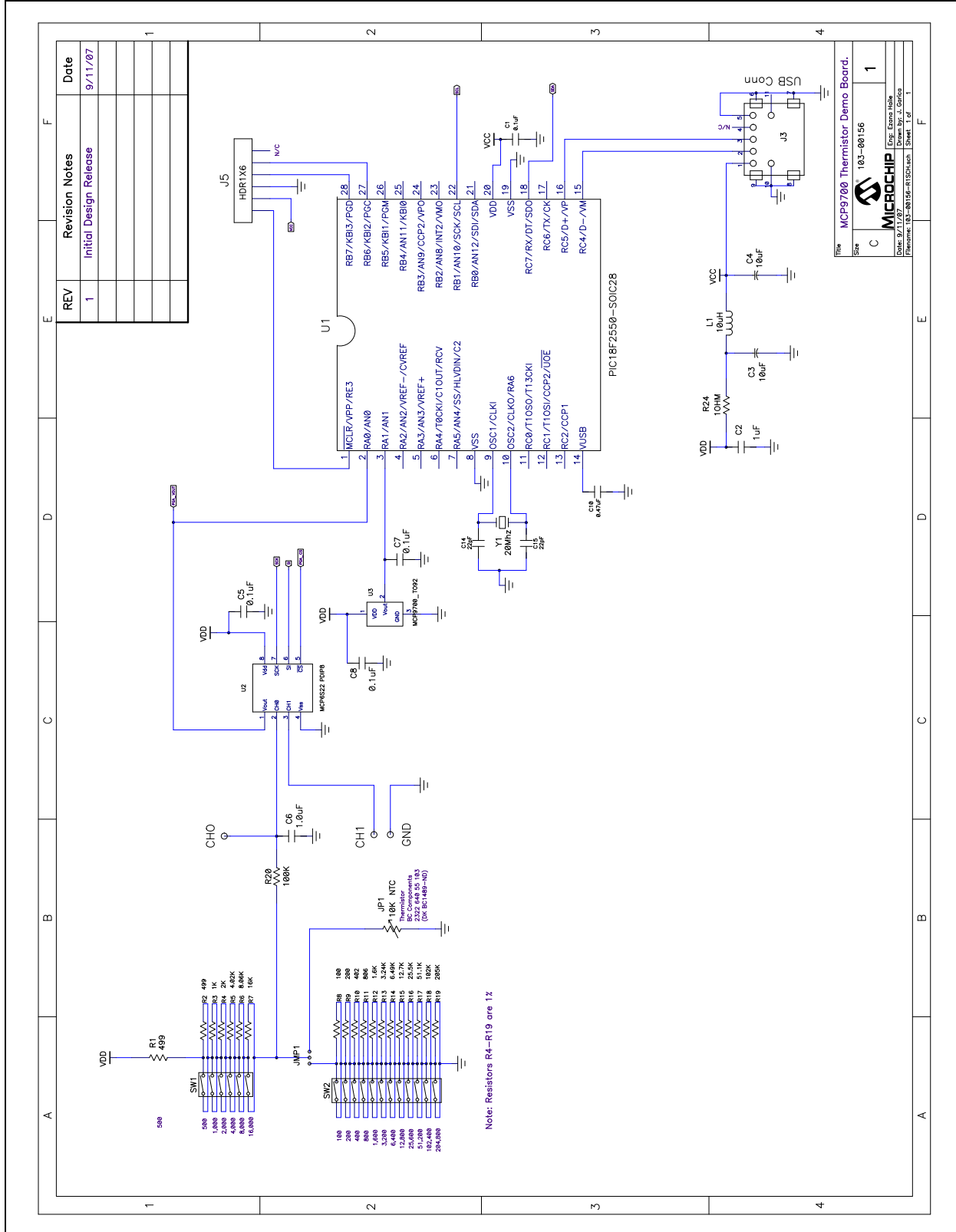

A.3 BOARD - TOP SILK-SCREEN LAYER

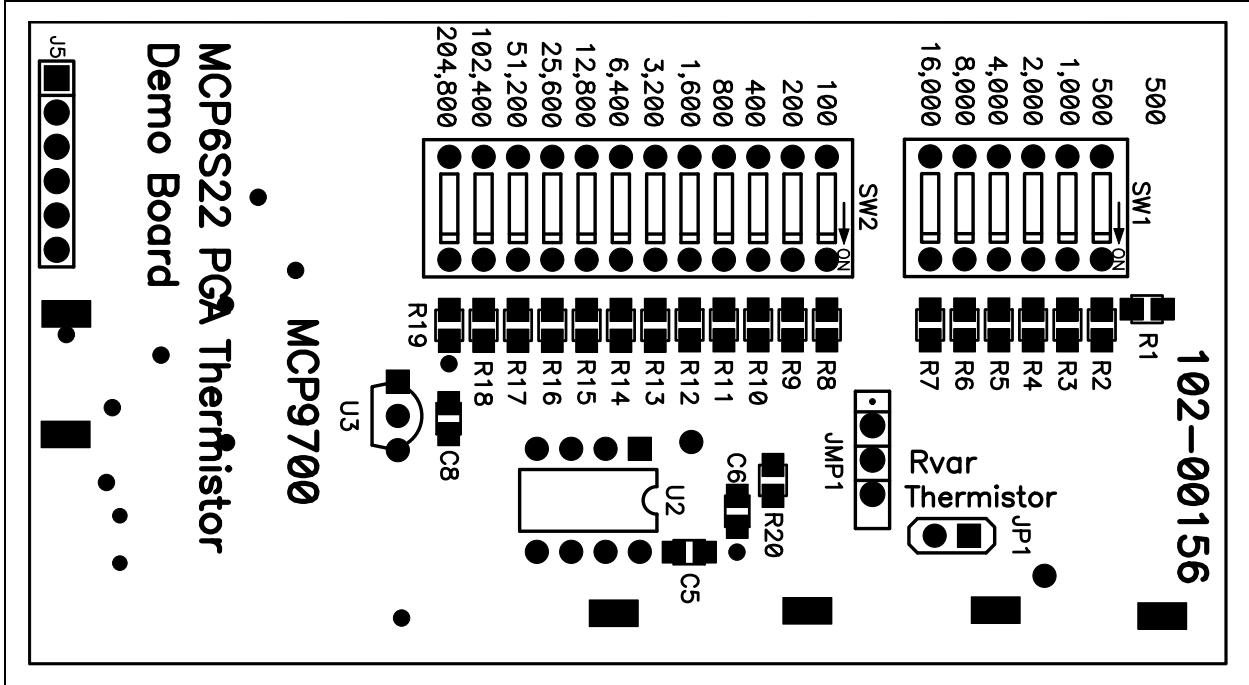

A.4 BOARD - TOP LAYER

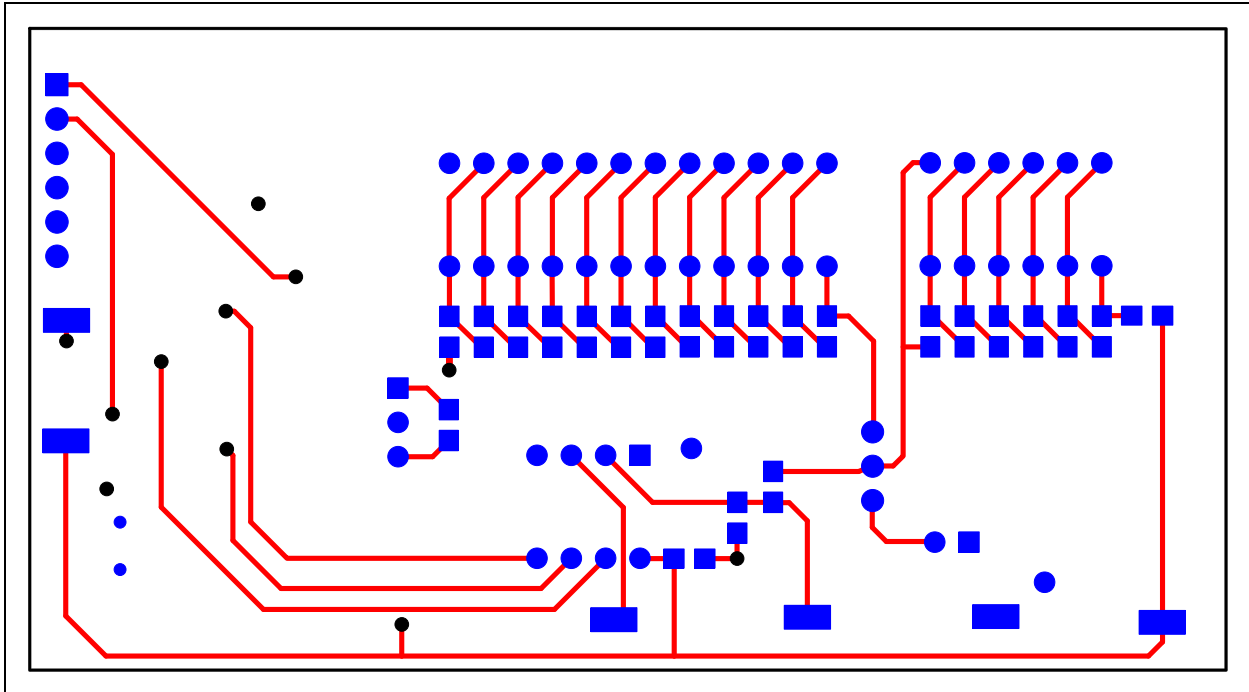

A.5 BOARD - BOTTOM SILK

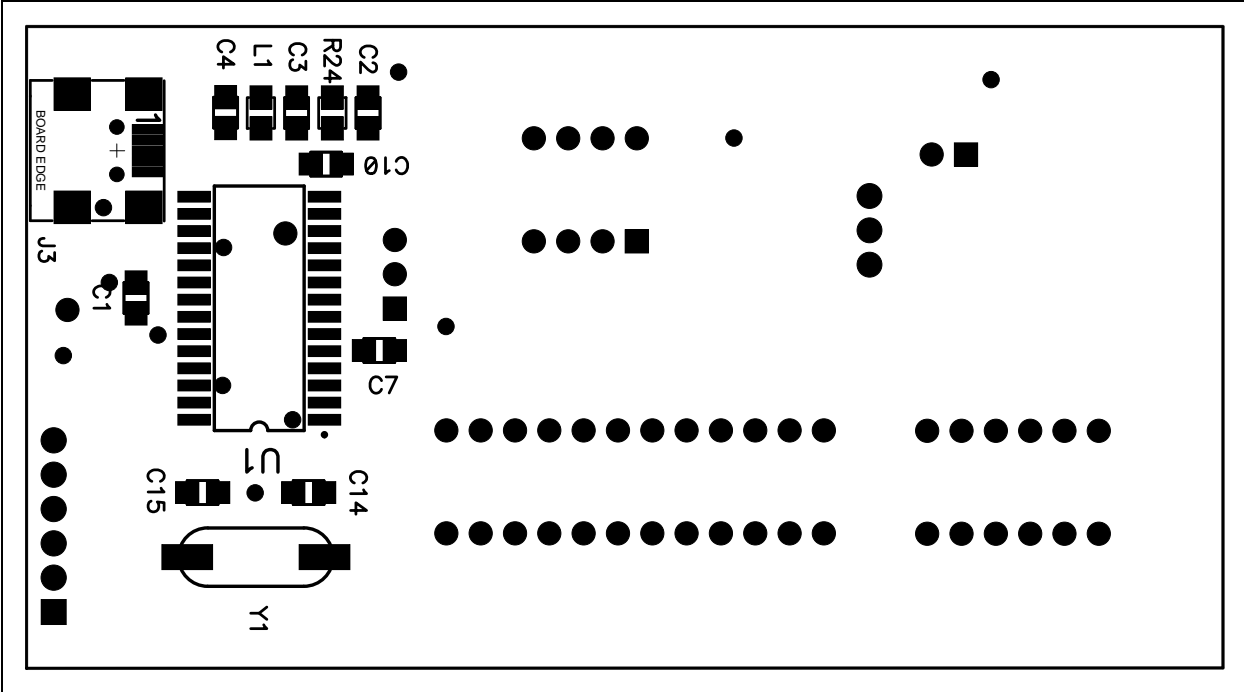

A.6 BOARD - BOTTOM LAYER

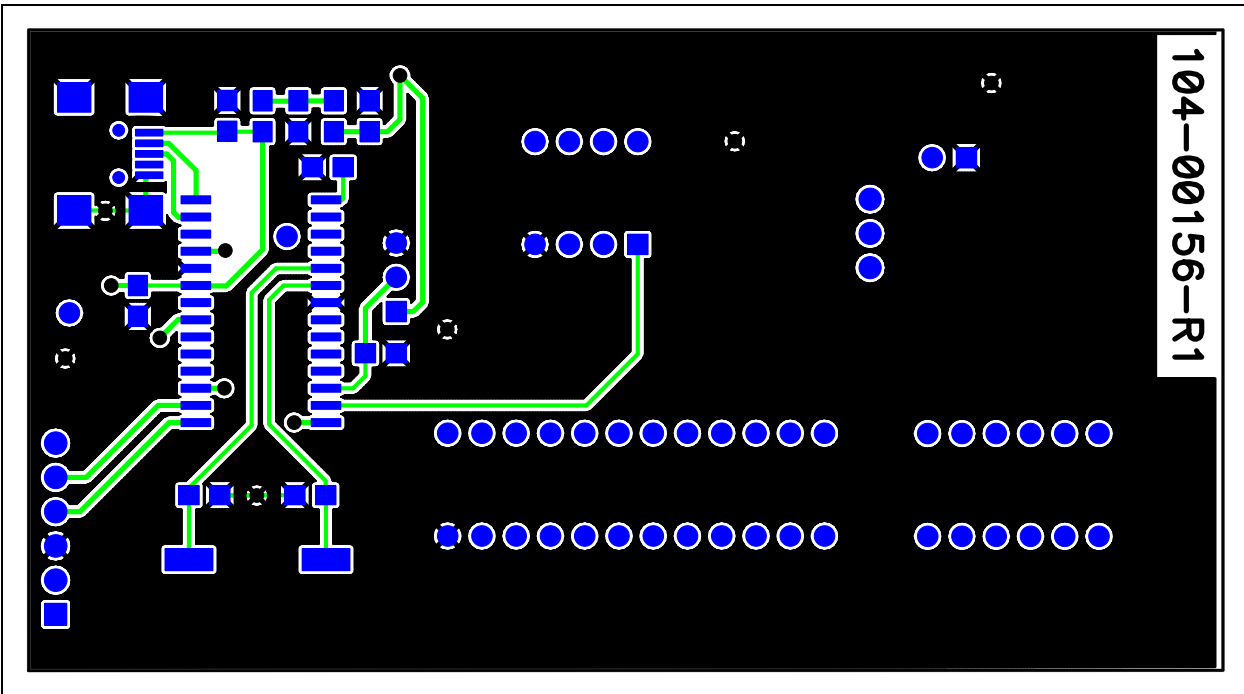

Appendix B. Bill Of Materials (BOM)

TABLE B-1: BILL OF MATERIALS

Qty	Reference	Description	Manufacturer	Part Number
1	(for JMP1)	Shunt - SOCKET, SHORT BLKS W TAB BLK	AMP®/Tyco Electronics	881545-2
1	(for U1)	CONN IC SOCKET 8POS DIP TIN	AMP/Tyco Electronics	2-641260-1
4	C1,C5,C7,C8	CAP .1UF 25V CERAMIC X7R 0805	Panasonic® - ECG	ECJ-2VB1E104K
1	C10	CAP .47UF 16V CERAMIC X7R 0805	Panasonic - ECG	ECJ-2YB1C474K
2	C14,C15	CAP 22PF 50V CERM CHIP 0805 SMD	Panasonic - ECG	ECJ-2VC1H220J
2	C2,C6	CAP 1.0UF 16V CERAMIC X7R 0805	Kemet® Electronics Corp	C0805C105K4RACTU
2	C3,C4	CAP 10UF 10V CERAMIC F 0805	Panasonic - ECG	ECJ-2FF1A106Z
6	CH0,CH1,GND, VDD	PC TEST POINT COMPACT SMT	Keystone Electronics®	5016
4	EA. Corner	BUMPON TALL TAPER SQ .50X.23 BK (Package comes in 64pcs per unit)	3M	SJ-5518 (BLACK)
1	J3	CONN RECEPT MINI USB2.0 5POS (mini USB)	Hirose Electronic Co Ltd	UX60-MB-5ST
	J5	"DO NOT POPULATE" CONN HEADER VERT 6POS .100 TIN	Tyco® Electronics/Amp	3-644695-6
1	JMP1	CONN HEADER 3POS 0.100 VERT TIN	AMP/Tyco Electronics	3-644456-3
1	JP1	THERMISTOR 10K OHM NTC LEADED	BC Components	2381 640 55103
1	L1	INDUCTOR 10UH 100MA 0805	Murata Electronics® - North America	LQM21FN100M70L
1	PCB	MCP9700 Thermistor Demo Board	Microchip Techgology Inc.	113-00156
2	R1,R2	RES 499 OHM 1/8W 1% 0805 SMD	Panasonic - ECG	ERJ-6ENF4990V
1	R10	RES 402 OHM 1/8W 1% 0805 SMD	Panasonic - ECG	ERJ-6ENF4020V
1	R11	RES 806 OHM 1/8W 1% 0805 SMD	Panasonic - ECG	ERJ-6ENF8060V
1	R12	RES 1.62K OHM 1/8W 1% 0805 SMD	Panasonic - ECG	ERJ-6ENF1621V
1	R13	RES 3.24K OHM 1/8W 1% 0805 SMD	Panasonic - ECG	ERJ-6ENF3241V
1	R14.	RES 6.49K OHM 1/8W 1% 0805 SMD	Panasonic - ECG	ERJ-6ENF6491V
1	R15	RES 12.7K OHM 1/8W 1% 0805 SMD	Panasonic - ECG	ERJ-6ENF1272V
1	R16	RES 25.5K OHM 1/8W 1% 0805 SMD	Panasonic - ECG	ERJ-6ENF2552V
1	R17	RES 51.1K OHM 1/8W 1% 0805 SMD	Panasonic - ECG	ERJ-6ENF5112V
1	R18	RES 102K OHM 1/8W 1% 0805 SMD	Panasonic - ECG	ERJ-6ENF1023V
1	R19	RES 205K OHM 1/8W 1% 0805 SMD	Panasonic - ECG	ERJ-6ENF2053V
1	R20	RES 100K OHM 1/8W 1% 0805 SMD	Panasonic - ECG	ERJ-6ENF1003V
1	R24	RES 10.0 OHM 1/8W 1% 0805 SMD	Panasonic - ECG	ERJ-6ENF10R0V

Note: The components listed in this Bill of Materials are representative of the PCB assembly. The released BOM used in manufacturing uses all RoHS-compliant components.

MCP9700 Thermistor Demo Board User's Guide

TABLE B-1: BILL OF MATERIALS (CONTINUED)

Qty	Reference	Description	Manufacturer	Part Number
1	R3	RES 1.00K OHM 1/8W 1% 0805 SMD	Panasonic - ECG	ERJ-6ENF1001V
1	R4	RES 2.00K OHM 1/8W 1% 0805 SMD	Panasonic - ECG	ERJ-6ENF2001V
1	R5	RES 4.02K OHM 1/8W 1% 0805 SMD	Panasonic - ECG	ERJ-6ENF4021V
1	R6	RES 8.06K OHM 1/8W 1% 0805 SMD	Panasonic - ECG	ERJ-6ENF8061V
1	R7	RES 16.2K OHM 1/8W 1% 0805 SMD	Panasonic - ECG	ERJ-6ENF1622V
1	R8	RES 100 OHM 1/8W 1% 0805 SMD	Panasonic - ECG	ERJ-6ENF1000V
1	R9	RES 200 OHM 1/8W 1% 0805 SMD	Panasonic - ECG	ERJ-6ENF2000V
1	SW1	SWITCH 6 POS DIP EXTENDED SEALED	Grayhill, Inc	78B06ST
1	SW2	SWITCH 12 POS DIP EXTENDED UNSLD	Grayhill, Inc	78B12ST
1	U1	28/40/44-Pin, High-Performance, Enhanced Flash, USB Microcontrollers with nanoWatt Technology	Microchip Technology Inc.	PIC18F2550-I/SO
1	U2	PGA, Rail-to-Rail I/O, Digital control	Microchip Technology Inc.	MCP6S22-I/P
1	U3	Low-Power Linear Active Thermistor™ Ics	Microchip Technology Inc.	MCP9700-E/TO
1	Y1	CRYSTAL 20.0000 MHZ SERIES SMT	CTS-Frequency Controls	ATS200SM

Note: The components listed in this Bill of Materials are representative of the PCB assembly. The released BOM used in manufacturing uses all RoHS-compliant components.

Bill Of Materials (BOM)

NOTES:



WORLDWIDE SALES AND SERVICE

AMERICAS

Corporate Office

2355 West Chandler Blvd.
Chandler, AZ 85224-6199
Tel: 480-792-7200
Fax: 480-792-7277
Technical Support:
<http://support.microchip.com>
Web Address:
www.microchip.com

Atlanta

Duluth, GA
Tel: 678-957-9614
Fax: 678-957-1455

Boston

Westborough, MA
Tel: 774-760-0087
Fax: 774-760-0088

Chicago

Itasca, IL
Tel: 630-285-0071
Fax: 630-285-0075

Dallas

Addison, TX
Tel: 972-818-7423
Fax: 972-818-2924

Detroit

Farmington Hills, MI
Tel: 248-538-2250
Fax: 248-538-2260

Kokomo

Kokomo, IN
Tel: 765-864-8360
Fax: 765-864-8387

Los Angeles

Mission Viejo, CA
Tel: 949-462-9523
Fax: 949-462-9608

Santa Clara

Santa Clara, CA
Tel: 408-961-6444
Fax: 408-961-6445

Toronto

Mississauga, Ontario,
Canada
Tel: 905-673-0699
Fax: 905-673-6509

ASIA/PACIFIC

Asia Pacific Office

Suites 3707-14, 37th Floor
Tower 6, The Gateway
Harbour City, Kowloon
Hong Kong
Tel: 852-2401-1200
Fax: 852-2401-3431

Australia - Sydney

Tel: 61-2-9868-6733
Fax: 61-2-9868-6755

China - Beijing

Tel: 86-10-8528-2100
Fax: 86-10-8528-2104

China - Chengdu

Tel: 86-28-8665-5511
Fax: 86-28-8665-7889

China - Hong Kong SAR

Tel: 852-2401-1200
Fax: 852-2401-3431

China - Nanjing

Tel: 86-25-8473-2460
Fax: 86-25-8473-2470

China - Qingdao

Tel: 86-532-8502-7355
Fax: 86-532-8502-7205

China - Shanghai

Tel: 86-21-5407-5533
Fax: 86-21-5407-5066

China - Shenyang

Tel: 86-24-2334-2829
Fax: 86-24-2334-2393

China - Shenzhen

Tel: 86-755-8203-2660
Fax: 86-755-8203-1760

China - Wuhan

Tel: 86-27-5980-5300
Fax: 86-27-5980-5118

China - Xiamen

Tel: 86-592-2388138
Fax: 86-592-2388130

China - Xian

Tel: 86-29-8833-7252
Fax: 86-29-8833-7256

China - Zhuhai

Tel: 86-756-3210040
Fax: 86-756-3210049

ASIA/PACIFIC

India - Bangalore

Tel: 91-80-4182-8400
Fax: 91-80-4182-8422

India - New Delhi

Tel: 91-11-4160-8631
Fax: 91-11-4160-8632

India - Pune

Tel: 91-20-2566-1512
Fax: 91-20-2566-1513

Japan - Yokohama

Tel: 81-45-471- 6166
Fax: 81-45-471-6122

Korea - Daegu

Tel: 82-53-744-4301
Fax: 82-53-744-4302

Korea - Seoul

Tel: 82-2-554-7200
Fax: 82-2-558-5932 or
82-2-558-5934

Malaysia - Kuala Lumpur

Tel: 60-3-6201-9857
Fax: 60-3-6201-9859

Malaysia - Penang

Tel: 60-4-227-8870
Fax: 60-4-227-4068

Philippines - Manila

Tel: 63-2-634-9065
Fax: 63-2-634-9069

Singapore

Tel: 65-6334-8870
Fax: 65-6334-8850

Taiwan - Hsin Chu

Tel: 886-3-572-9526
Fax: 886-3-572-6459

Taiwan - Kaohsiung

Tel: 886-7-536-4818
Fax: 886-7-536-4803

Taiwan - Taipei

Tel: 886-2-2500-6610
Fax: 886-2-2508-0102

Thailand - Bangkok

Tel: 66-2-694-1351
Fax: 66-2-694-1350

EUROPE

Austria - Wels

Tel: 43-7242-2244-39
Fax: 43-7242-2244-393

Denmark - Copenhagen

Tel: 45-4450-2828
Fax: 45-4485-2829

France - Paris

Tel: 33-1-69-53-63-20
Fax: 33-1-69-30-90-79

Germany - Munich

Tel: 49-89-627-144-0
Fax: 49-89-627-144-44

Italy - Milan

Tel: 39-0331-742611
Fax: 39-0331-466781

Netherlands - Drunen

Tel: 31-416-690399
Fax: 31-416-690340

Spain - Madrid

Tel: 34-91-708-08-90
Fax: 34-91-708-08-91

UK - Wokingham

Tel: 44-118-921-5869
Fax: 44-118-921-5820



Компания «ЭлектроПласт» предлагает заключение долгосрочных отношений при поставках импортных электронных компонентов на взаимовыгодных условиях!

Наши преимущества:

- Оперативные поставки широкого спектра электронных компонентов отечественного и импортного производства напрямую от производителей и с крупнейших мировых складов;
- Поставка более 17-ти миллионов наименований электронных компонентов;
- Поставка сложных, дефицитных, либо снятых с производства позиций;
- Оперативные сроки поставки под заказ (от 5 рабочих дней);
- Экспресс доставка в любую точку России;
- Техническая поддержка проекта, помощь в подборе аналогов, поставка прототипов;
- Система менеджмента качества сертифицирована по Международному стандарту ISO 9001;
- Лицензия ФСБ на осуществление работ с использованием сведений, составляющих государственную тайну;
- Поставка специализированных компонентов (Xilinx, Altera, Analog Devices, Intersil, Interpoint, Microsemi, Aeroflex, Peregrine, Syfer, Eurofarad, Texas Instrument, Miteq, Cobham, E2V, MA-COM, Hittite, Mini-Circuits, General Dynamics и др.);

Помимо этого, одним из направлений компании «ЭлектроПласт» является направление «Источники питания». Мы предлагаем Вам помощь Конструкторского отдела:

- Подбор оптимального решения, техническое обоснование при выборе компонента;
- Подбор аналогов;
- Консультации по применению компонента;
- Поставка образцов и прототипов;
- Техническая поддержка проекта;
- Защита от снятия компонента с производства.



Как с нами связаться

Телефон: 8 (812) 309 58 32 (многоканальный)

Факс: 8 (812) 320-02-42

Электронная почта: org@eplast1.ru

Адрес: 198099, г. Санкт-Петербург, ул. Калинина, дом 2, корпус 4, литера А.