

800-mA, Single-Input, Single-Cell, Li-Ion Battery Solar Charger With Power Path

This user's guide describes the features and operation of the bq24210/2 Evaluation Module (EVM). The EVM assists users in evaluating the bq24210/2 solar charger. The printed-circuit board for the EVM is labeled HPA678. The manual includes the bq24210/2EVM bill of materials, board layout, and schematic.

Contents

1	Introduction	2
	1.1 EVM Features	2
	1.2 General Description	2
	1.3 I/O Header Descriptions	2
	1.4 Jumper Settings	3
	1.5 Recommended Operating Conditions	3
2	Test Summary	4
	2.1 Definitions	4
	2.2 Recommended Equipment for Testing	5
	2.3 Recommended Test Equipment Setup	5
	2.4 Recommended Test Procedure to Confirm IC Operation	6
3	PCB Layout Guideline	6
4	Bill of Materials, Board Layout, and Schematics	7
	4.1 Bill of Materials	7
	4.2 Board Layout	8
	4.3 Schematics	11

List of Figures

1	Original Test Setup for HPA678 (bq24210/2EVM)	5
2	Top Assembly	8
3	Top Layer	9
4	Bottom Layer	10
5	bq24210 EVM Schematic	11

List of Tables

1	I/O Header Descriptions	2
2	Jumper Settings	3
3	Recommended Operating Conditions	3
4	Bill of Materials	7

1 Introduction

1.1 EVM Features

- 800-mA, single-input, single-cell Li-ion battery solar charger with Power Path
- Resistor-programmable setting for charge current and input voltage dynamic power management
- LED Indication for status
- Test points for key signals available for testing purposes – easy probe hook-up
- Jumpers available – easy to change setting

1.2 General Description

The bq24210/2 series of devices are highly integrated Li-ion linear chargers devices targeted at space-limited portable applications. The high input voltage range with input overvoltage protection supports low-cost unregulated adapters. The input voltage regulation loop with programmable input voltage regulation threshold make it suitable for charging from alternative power sources, such as solar panel or inductive charging pad. The integrated circuit (IC) has a single power output that charges the battery. A system load can be placed in parallel with the battery as long as the average system load does not keep the battery from charging fully during the 10-hour safety timer. The bq24210 has an $\overline{\text{EN}}$ pin whereas the bq24212 has a MODE pin. See the data sheet for an explanation of the differences between the two pins.

The battery is charged in three phases: conditioning, constant current and constant voltage. In all charge phases, an internal control loop monitors the IC junction temperature and reduces the charge current if an internal temperature threshold is exceeded.

For additional details, see the bq24210 or bq24212 data sheet.

1.3 I/O Header Descriptions

Table 1. I/O Header Descriptions

Jack	Description
J1-VBUS	Positive input
J1-GND	Negative input
J2-BAT	Charger output
J2-GND	Ground
J2-TS	Temperature qualification input
J3-GND	Ground
J3-VDPM	Programs the input voltage regulation threshold
J3-CHG	Charge status indication
J3- $\overline{\text{EN}}$ (BQ24210 only)	Chip ENable control. This pin must be pulled low in order for the device to operate.
J3-MODE (BQ24212 only)	Chip MODE control. See data sheet for explanation of chip operation when MODE is high and low.
J3- $\overline{\text{PG}}$	Power present indication
J4-ISET	Programs the fast-charge current setting
J4-VTSB	TS bias reference voltage pin, regulated output
J4-GND	Ground

1.4 Jumper Settings

Table 2. Jumper Settings

Jack	Description	Factory Setting
JP1	Programs the fast-charge current setting. 500 mA when JP1 ON; external setting when JP1 OFF	Jumper OFF (external setting)
JP2	Connect /EN and /PG together when JP2 ON to enable charger when power present	Jumper OFF (external /EN)
JP3	Programs the input voltage regulation threshold. 4.5V when JP3 ON; external setting when JP3 OFF.	Jumper OFF (external setting)
JP4	Limited power charge mode (LPCM) when JP4 ON; normal operation when JP4 OFF	Jumper OFF (normal operation)
JP5	Select external TS input or internal TS setting 1-2 : External TS input 2-3 : Internal TS setting	Jumper ON 1-2 (external TS)
JP6	The pullup power source supplies for the LEDs 1-2 : BAT 2-3 : VBUS	Jumper ON 2-3 (VBUS)
JP7	Charger \overline{EN} / MODE 1-2 : OFF/HIGH 2-3 : ON/LOW	Jumper ON 1-2 (charger OFF / MODE High)

1.5 Recommended Operating Conditions

Table 3. Recommended Operating Conditions

	Description	Min	Typ	Max	Unit	Notes
Supply voltage, V_{BUS}	Input voltage	4.5		7.3	V	
Battery voltage, V_{BAT}	Voltage applied at VBAT terminal of J2	0		4.2	V	
Supply current	Maximum input current	0		0.8	A	
Charge current, I_{chrg}	Battery charge current	0		0.8	A	
Operating junction temperature range, T_J		0		125	°C	

An external resistor is used to program the VBUS_DPM. The programming resistor, R_{VDPM} is dictated by the following equation:

$$R_{VDPM} = \frac{(VBUS_DPM - VBUS_DPM_1)}{KVBUS_DPM} \quad (1)$$

Where:

$VBUS_DPM$ is the desired input voltage regulation voltage threshold.

$VBUS_DPM_1$ is the built-in offset threshold, nominally 3.5 V.

K_{VBUS_DPM} is a gain factor found in the electrical specification.

If VDPM pin is shorted to VSS; the $VBUS_DPM$ must be clamped to 3.65 V.

If the VDPM pin is floated (open circuit), the IC operates in Battery Tracking mode. In this case, VBUS DPM threshold is internally set as V_{TRK} , which is $BAT + 100\text{ mV}$. ($BAT > 3.65\text{ V}$) or 3.75 V ($BAT \leq 3.4\text{ V}$).

Connecting JP3 set 4.5 V VDPM on EVM.

An external resistor is used to program the output current (50-800 mA). The equation for charge current is:

$$R_{ISET} = \frac{K_{ISET}}{I_{OUT}} \quad (2)$$

Where, I_{OUT} is the desired fast-charge current; K_{ISET} is a gain factor found in the specification.

The termination and precharge current are internally set at 10% and 20% of fast-charge current, respectively. The precharge-to-fast-charge, V_{lowv} threshold is set to 2.5 V.

Connecting JP1 set 500 mADC for fast-charge current and 100 mADC for precharge current on EVM.

2 Test Summary

2.1 Definitions

This procedure details how to configure the HPA678 evaluation board. On the test procedure, the following naming conventions are followed.

VXXX :	External voltage supply name (VBUS, VBAT)
LOADW:	External load name (LOADR, LOADI)
V(TPyyy):	Voltage at internal test point (TPyyy). For example, V(TP1) means the voltage at TP1.
V(Jxx):	Voltage at jack terminal (Jxx).
V(XXX):	Voltage at (XXX). For example, V(VDPM) means the voltage at the test point which is marked VDPM.
V(XXX, YYY):	Voltage across point XXX and YYY.
I(JXX(YYY)):	Current going out from the YYY terminal of jack XX.
Jxx(BBB):	Terminal or pin BBB of jack xx
Jxx ON :	Internal jumper Jxx terminals are shorted.
Jxx OFF:	Internal jumper Jxx terminals are open.
Jxx (-YY-) ON:	Internal jumper Jxx adjacent terminals marked as YY are shorted.
Measure:→A,B	Check specified parameters A, B. If measured values are not within specified limits, the unit under test has failed.
Observe →A,B	Observe if A, B occur. If they do not occur, the unit under test has failed.

Assembly drawings have location for jumpers, test points, and individual components

2.2 Recommended Equipment for Testing

2.2.1 Power Supplies

Power Supply #1 (PS#1): a power supply capable of supplying 20 V at 1 A

2.2.2 Loads

A 20-V (or above), 1-A (or above) electronic load that can operate at constant current and constant voltage mode or equivalent

2.2.3 Meters

Four Fluke 75 multimeters, (equivalent or better) or two equivalent voltage meters and two equivalent current meters. The current meters must be capable of measuring 1 A + current.

2.3 Recommended Test Equipment Setup

1. Set the power supply #1 (PS#1) for 6.5 V \pm 200 mVDC, 1-A \pm 0.1-A current limit, and then turn off supply.
2. Connect the output of PS#1 in series with a current meter (multimeter) to J1 (VBUS, GND).
3. Connect a voltage meter across J1 (VBUS, GND).
4. Connect Load #1 in series with a current meter to J2 (VBAT, GND). Turn off Load #1.
5. Connect a voltage meter across J2 (VBAT, GND).
6. Check all jumper shunts. JP1: OFF; JP2: OFF; JP3: OFF; JP4: OFF; JP5: connect 1-2 (External TS); JP6: connect 2-3 (VBUS); JP7: connect 1-2 (charger OFF/ MODE high).

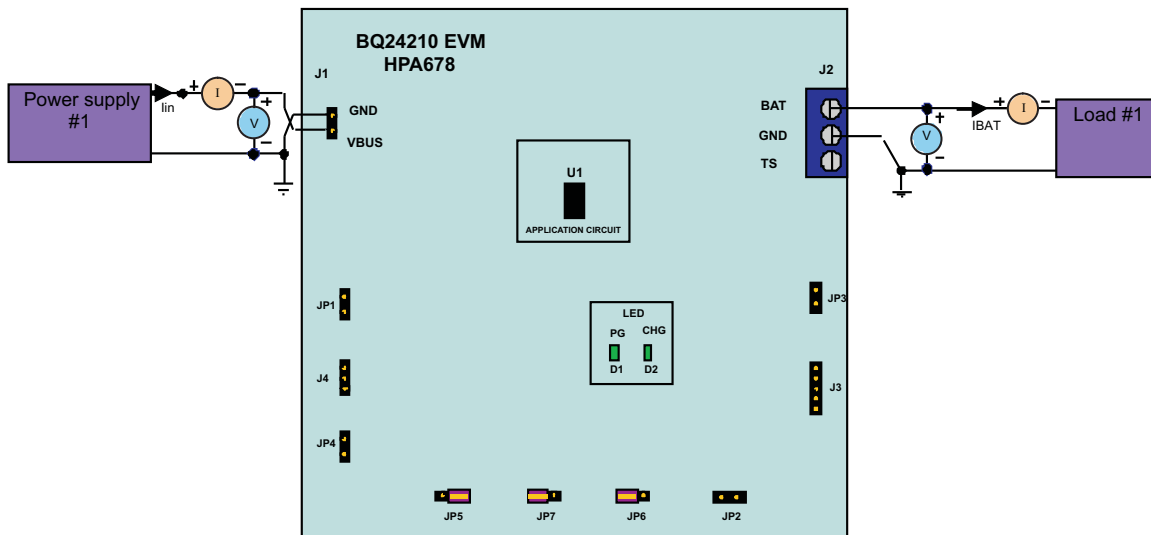

Figure 1. Original Test Setup for HPA678 (bq24210/2EVM)

2.4 Recommended Test Procedure to Confirm IC Operation

2.4.1 Power Supply

Make sure that EQUIPMENT SETUP steps are followed.

Disconnect LOAD #1. Turn on PS#1.

Measure → $V(J1(VBUS)) = 6.5 \text{ V} \pm 200 \text{ mV}$

Measure → $V(J2(VBAT)) = 0 \text{ V} \pm 200 \text{ mV}$

Measure → $V(J4(VTSB)) = 0 \text{ V} \pm 200 \text{ mV}$

Observe → D1 (PG) ON, D2 (CHG) OFF

2.4.2 Charger Enable and Battery Detection

Connect JP1; Connect 2-3 of JP7 (Charger ON/MODE High)

Measure → $V(J4(VTSB)) = 2.2 \text{ V} \pm 300 \text{ mV}$

Connect 2-3 of JP5 (Internal TS);

Adjust R6 until $V(JP4-1) = 0.7 \text{ V} \pm 200 \text{ mV}$

Measure → $V(J2(VBAT)) = 4.2 \text{ V} \pm 200 \text{ mV}$

Observe → D1 (PG) ON, D2 (CHG) OFF

2.4.3 Charge Current/Voltage Regulation

Reconnect LOAD#1. Turn on. Use the constant voltage mode.

Connect JP1; Set the output voltage to be 2.2 V.

Measure → $I(J2(VBAT)) = 0.1 \text{ A} \pm 50 \text{ mA}$

Observe → D1 (PG) ON, D2 (CHG) ON

Increase the voltage of LOAD#1 to be 3.5 V.

Measure → $I(J2(VBAT)) = 0.5 \text{ A} \pm 100 \text{ mA}$

Observe → D1 (PG) ON, D2 (CHG) ON

3 PCB Layout Guideline

1. It is critical that the exposed thermal pad on the backside of the bq24210 package be soldered to the PCB ground. Ensure that sufficient thermal vias are right underneath the IC, connecting to the ground plane on the other layers.
2. Make the interconnections of the decoupling capacitors for VBUS, BATT to the IC as short as possible.
3. Use the EVM layout for design reference.

4 Bill of Materials, Board Layout, and Schematics

4.1 Bill of Materials

Table 4. Bill of Materials

Count		RefDes	Value	Description	Size	Part Number
-001	-002					
1	1	C1	10uF	Capacitor, Ceramic, 25V,X7R, 10%	1206	STD
2	2	C2, C4	0.1uF	Capacitor, Ceramic, 25V, X7R, 10%	0603	STD
1	1	C3	10uF	Capacitor, Ceramic, 6.3V, X7R, 10%	0805	STD
0	0	C5, C6	Open	Capacitor, Ceramic, 25V, X7R, 10%	0603	STD
2	2	D1, D2	LTST-C190CKT	Diode, LED, Red, 1.8-V, 20-mA, 20-mcd	0603	LTST-C190CKT
1	1	D3	BZX84C5V1-7	Diode, Zener, 5.1V, 350-mW	SOT-23	BZX84C5V1-7
1	1	J1	PEC02SAAN	Header, Male 2-pin, 100mil spacing,	0.100 inch x 2	PEC02SAAN
1	1	J2	ED555/3DS	Terminal Block, 3-pin, 6-A, 3.5mm	0.41 x 0.25 inch	ED555/3DS
1	1	J3	PEC05SAAN	Header, Male 5-pin, 100mil spacing,	0.100 inch x 5	PEC05SAAN
1	1	J4	PEC03SAAN	Header, Male 3-pin, 100mil spacing,	0.100 inch x 3	PEC03SAAN
4	4	JP1, JP2, JP3, JP4	PEC02SAAN	Header, 2-pin, 100mil spacing,	0.100 inch x 2	PEC02SAAN
3	3	JP5, JP6, JP7	PEC03SAAN	Header, 3 pin, 100mil spacing,	0.100 inch x 3	PEC03SAAN
1	1	R1	21.5k	Resistor, Chip, 1/16W, 1%	0603	STD
2	2	R2, R4	1.50K	Resistor, Chip, 1/16W, 1%	0603	STD
1	1	R3	750	Resistor, Chip, 1/16W, 1%	0603	STD
1	1	R5	6.65k	Resistor, Chip, 1/16W, 1%	0603	Std
1	1	R6	100k	Potentiometer, 1/4 Cermet, 12-Turn, Top-Adjust	0.25x0.17 inch	3266W-1-104LF
1	1	R7	4.75k	Resistor, Chip, 1/16-W, 1%	0603	STD
0	0	TP1, TP2, TP3	Open	Test Point, 0.020 Hole		STD
1	0	U1	BQ24210DQC	IC, 800mA, Single-Input, Single Cell Li-Ion Battery Solar Charger with bi-directional Power Path	TDFN-10	BQ24210DQC
0	1	U1	BQ24212DQC	IC, 800mA, Single-Input, Single Cell Li-Ion Battery Solar Charger with bi-directional Power Path	TDFN-10	BQ24212DQC
7	7	—		Shunt, 100-mil, Black	0.1	929950-00
1	1	—		PCB, 2.64" x 2.1" x 0.062"		HPA678
1	1	—		Label	1.25 x 0.25 inch	THT-13-457-10

- Notes: 1. These assemblies are ESD sensitive, ESD precautions shall be observed.
2. These assemblies must be clean and free from flux and all contaminants. Use of no clean flux is not acceptable.
3. These assemblies must comply with workmanship standards IPC-A-610 Class 2.
4. Ref designators marked with an asterisk (***) cannot be substituted. All other components can be substituted with equivalent MFG's components.
5. Install label after final wash. Text shall be 8 pt font. Text shall be per Table 1.

Table 1

Assembly Number	Text
HPA678-001	BQ24210EVM-678
HPA678-002	BQ24212EVM-678

4.2 Board Layout

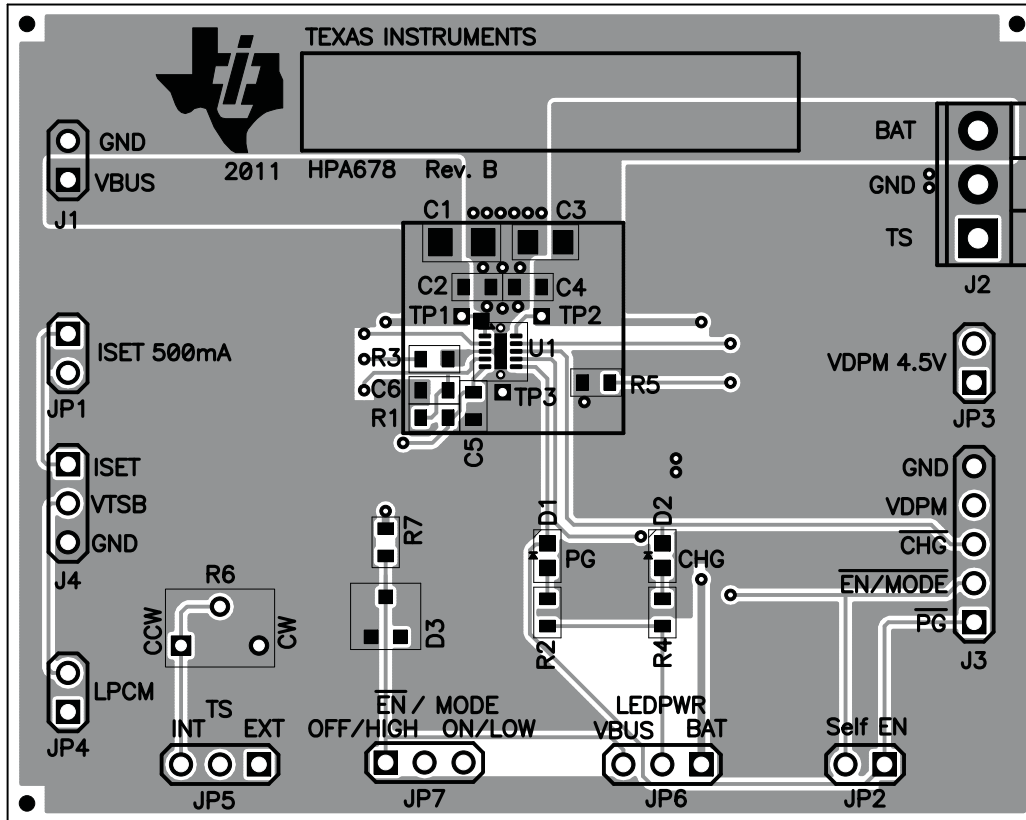

Figure 2. Top Assembly

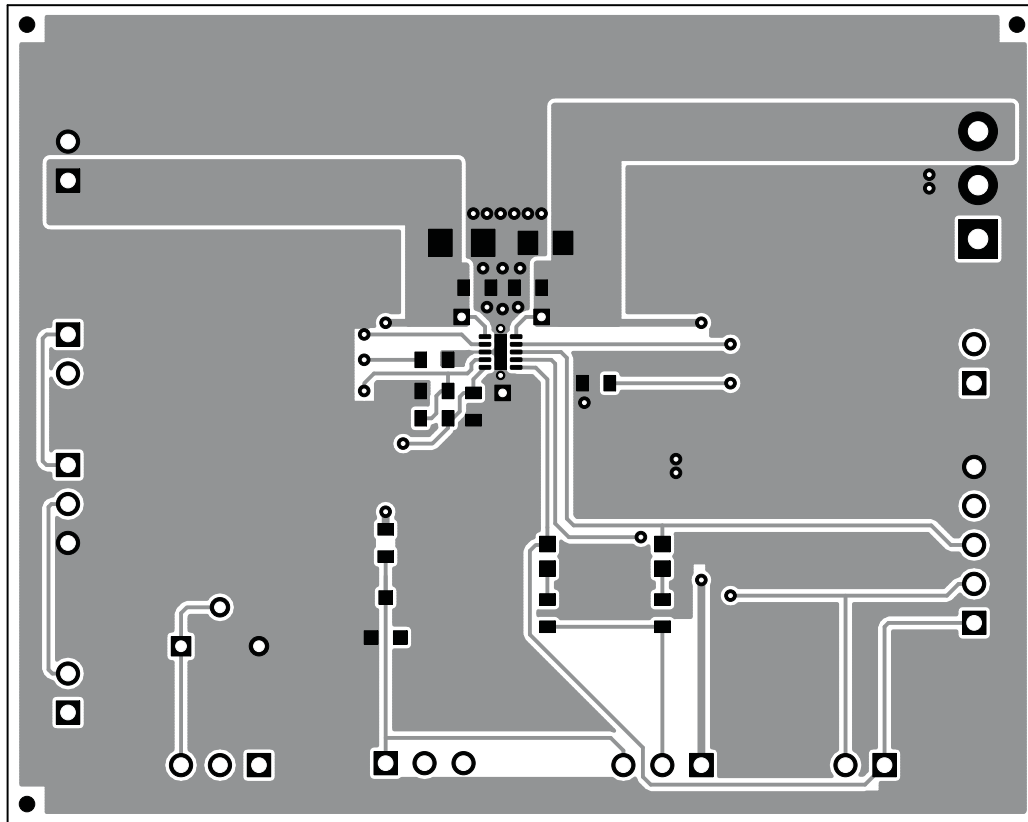

Figure 3. Top Layer

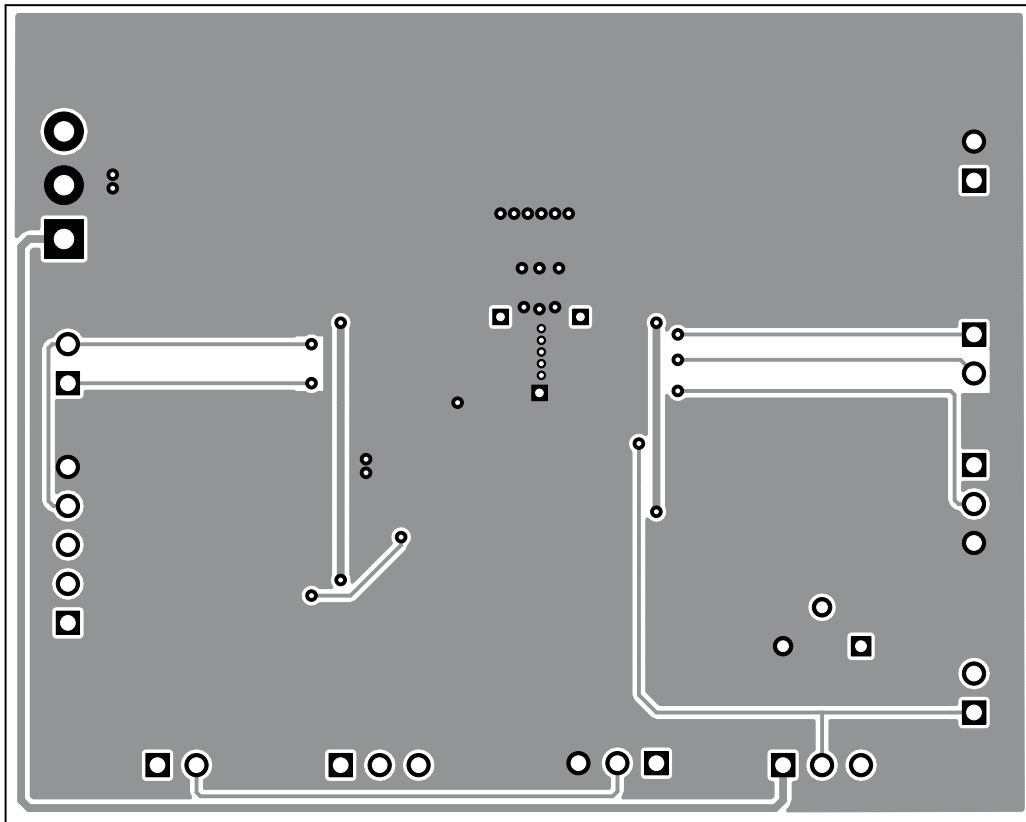

Figure 4. Bottom Layer

4.3 Schematics

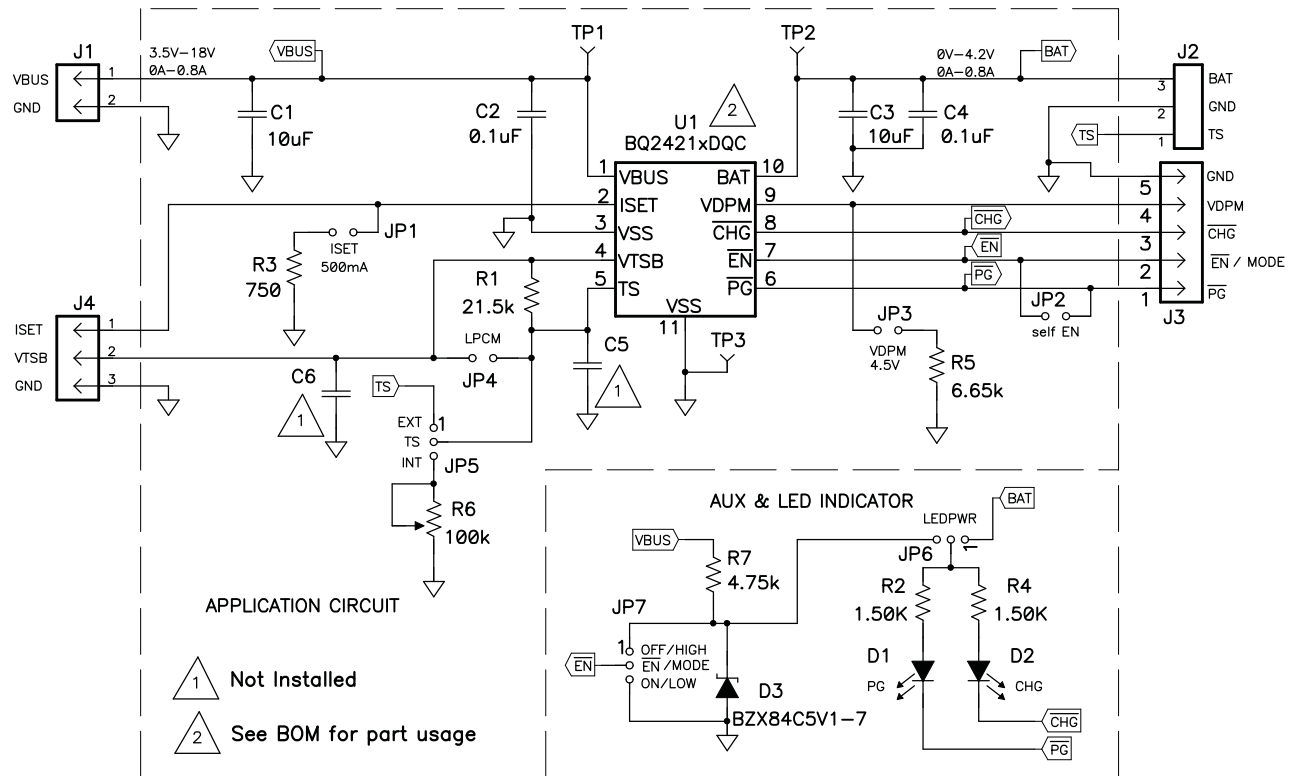

Figure 5. bq24210 EVM Schematic

Evaluation Board/Kit Important Notice

Texas Instruments (TI) provides the enclosed product(s) under the following conditions:

This evaluation board/kit is intended for use for **ENGINEERING DEVELOPMENT, DEMONSTRATION, OR EVALUATION PURPOSES ONLY** and is not considered by TI to be a finished end-product fit for general consumer use. Persons handling the product(s) must have electronics training and observe good engineering practice standards. As such, the goods being provided are not intended to be complete in terms of required design-, marketing-, and/or manufacturing-related protective considerations, including product safety and environmental measures typically found in end products that incorporate such semiconductor components or circuit boards. This evaluation board/kit does not fall within the scope of the European Union directives regarding electromagnetic compatibility, restricted substances (RoHS), recycling (WEEE), FCC, CE or UL, and therefore may not meet the technical requirements of these directives or other related directives.

Should this evaluation board/kit not meet the specifications indicated in the User's Guide, the board/kit may be returned within 30 days from the date of delivery for a full refund. **THE FOREGOING WARRANTY IS THE EXCLUSIVE WARRANTY MADE BY SELLER TO BUYER AND IS IN LIEU OF ALL OTHER WARRANTIES, EXPRESSED, IMPLIED, OR STATUTORY, INCLUDING ANY WARRANTY OF MERCHANTABILITY OR FITNESS FOR ANY PARTICULAR PURPOSE.**

The user assumes all responsibility and liability for proper and safe handling of the goods. Further, the user indemnifies TI from all claims arising from the handling or use of the goods. Due to the open construction of the product, it is the user's responsibility to take any and all appropriate precautions with regard to electrostatic discharge.

EXCEPT TO THE EXTENT OF THE INDEMNITY SET FORTH ABOVE, NEITHER PARTY SHALL BE LIABLE TO THE OTHER FOR ANY INDIRECT, SPECIAL, INCIDENTAL, OR CONSEQUENTIAL DAMAGES.

TI currently deals with a variety of customers for products, and therefore our arrangement with the user **is not exclusive.**

TI assumes **no liability for applications assistance, customer product design, software performance, or infringement of patents or services described herein.**

Please read the User's Guide and, specifically, the Warnings and Restrictions notice in the User's Guide prior to handling the product. This notice contains important safety information about temperatures and voltages. For additional information on TI's environmental and/or safety programs, please contact the TI application engineer or visit www.ti.com/esh.

No license is granted under any patent right or other intellectual property right of TI covering or relating to any machine, process, or combination in which such TI products or services might be or are used.

FCC Warning

This evaluation board/kit is intended for use for **ENGINEERING DEVELOPMENT, DEMONSTRATION, OR EVALUATION PURPOSES ONLY** and is not considered by TI to be a finished end-product fit for general consumer use. It generates, uses, and can radiate radio frequency energy and has not been tested for compliance with the limits of computing devices pursuant to part 15 of FCC rules, which are designed to provide reasonable protection against radio frequency interference. Operation of this equipment in other environments may cause interference with radio communications, in which case the user at his own expense will be required to take whatever measures may be required to correct this interference.

EVM Warnings and Restrictions

It is important to operate this EVM within the input voltage range of 4.5 V to 7.3 V and the output voltage range of 0 V to 4.2 V .

Exceeding the specified input range may cause unexpected operation and/or irreversible damage to the EVM. If there are questions concerning the input range, please contact a TI field representative prior to connecting the input power.

Applying loads outside of the specified output range may result in unintended operation and/or possible permanent damage to the EVM. Please consult the EVM User's Guide prior to connecting any load to the EVM output. If there is uncertainty as to the load specification, please contact a TI field representative.

During normal operation, some circuit components may have case temperatures greater than 60°C. The EVM is designed to operate properly with certain components above 125°C as long as the input and output ranges are maintained. These components include but are not limited to linear regulators, switching transistors, pass transistors, and current sense resistors. These types of devices can be identified using the EVM schematic located in the EVM User's Guide. When placing measurement probes near these devices during operation, please be aware that these devices may be very warm to the touch.

Mailing Address: Texas Instruments, Post Office Box 655303, Dallas, Texas 75265
Copyright © 2011, Texas Instruments Incorporated

IMPORTANT NOTICE

Texas Instruments Incorporated and its subsidiaries (TI) reserve the right to make corrections, modifications, enhancements, improvements, and other changes to its products and services at any time and to discontinue any product or service without notice. Customers should obtain the latest relevant information before placing orders and should verify that such information is current and complete. All products are sold subject to TI's terms and conditions of sale supplied at the time of order acknowledgment.

TI warrants performance of its hardware products to the specifications applicable at the time of sale in accordance with TI's standard warranty. Testing and other quality control techniques are used to the extent TI deems necessary to support this warranty. Except where mandated by government requirements, testing of all parameters of each product is not necessarily performed.

TI assumes no liability for applications assistance or customer product design. Customers are responsible for their products and applications using TI components. To minimize the risks associated with customer products and applications, customers should provide adequate design and operating safeguards.

TI does not warrant or represent that any license, either express or implied, is granted under any TI patent right, copyright, mask work right, or other TI intellectual property right relating to any combination, machine, or process in which TI products or services are used. Information published by TI regarding third-party products or services does not constitute a license from TI to use such products or services or a warranty or endorsement thereof. Use of such information may require a license from a third party under the patents or other intellectual property of the third party, or a license from TI under the patents or other intellectual property of TI.

Reproduction of TI information in TI data books or data sheets is permissible only if reproduction is without alteration and is accompanied by all associated warranties, conditions, limitations, and notices. Reproduction of this information with alteration is an unfair and deceptive business practice. TI is not responsible or liable for such altered documentation. Information of third parties may be subject to additional restrictions.

Resale of TI products or services with statements different from or beyond the parameters stated by TI for that product or service voids all express and any implied warranties for the associated TI product or service and is an unfair and deceptive business practice. TI is not responsible or liable for any such statements.

TI products are not authorized for use in safety-critical applications (such as life support) where a failure of the TI product would reasonably be expected to cause severe personal injury or death, unless officers of the parties have executed an agreement specifically governing such use. Buyers represent that they have all necessary expertise in the safety and regulatory ramifications of their applications, and acknowledge and agree that they are solely responsible for all legal, regulatory and safety-related requirements concerning their products and any use of TI products in such safety-critical applications, notwithstanding any applications-related information or support that may be provided by TI. Further, Buyers must fully indemnify TI and its representatives against any damages arising out of the use of TI products in such safety-critical applications.

TI products are neither designed nor intended for use in military/aerospace applications or environments unless the TI products are specifically designated by TI as military-grade or "enhanced plastic." Only products designated by TI as military-grade meet military specifications. Buyers acknowledge and agree that any such use of TI products which TI has not designated as military-grade is solely at the Buyer's risk, and that they are solely responsible for compliance with all legal and regulatory requirements in connection with such use.

TI products are neither designed nor intended for use in automotive applications or environments unless the specific TI products are designated by TI as compliant with ISO/TS 16949 requirements. Buyers acknowledge and agree that, if they use any non-designated products in automotive applications, TI will not be responsible for any failure to meet such requirements.

Following are URLs where you can obtain information on other Texas Instruments products and application solutions:

Products

Audio	www.ti.com/audio
Amplifiers	amplifier.ti.com
Data Converters	dataconverter.ti.com
DLP® Products	www.dlp.com
DSP	dsp.ti.com
Clocks and Timers	www.ti.com/clocks
Interface	interface.ti.com
Logic	logic.ti.com
Power Mgmt	power.ti.com
Microcontrollers	microcontroller.ti.com
RFID	www.ti-rfid.com
RF/IF and ZigBee® Solutions	www.ti.com/lprf

Applications

Communications and Telecom	www.ti.com/communications
Computers and Peripherals	www.ti.com/computers
Consumer Electronics	www.ti.com/consumer-apps
Energy and Lighting	www.ti.com/energy
Industrial	www.ti.com/industrial
Medical	www.ti.com/medical
Security	www.ti.com/security
Space, Avionics and Defense	www.ti.com/space-avionics-defense
Transportation and Automotive	www.ti.com/automotive
Video and Imaging	www.ti.com/video
Wireless	www.ti.com/wireless-apps

TI E2E Community Home Page

e2e.ti.com

Mailing Address: Texas Instruments, Post Office Box 655303, Dallas, Texas 75265
Copyright © 2011, Texas Instruments Incorporated



Компания «ЭлектроПласт» предлагает заключение долгосрочных отношений при поставках импортных электронных компонентов на взаимовыгодных условиях!

Наши преимущества:

- Оперативные поставки широкого спектра электронных компонентов отечественного и импортного производства напрямую от производителей и с крупнейших мировых складов;
- Поставка более 17-ти миллионов наименований электронных компонентов;
- Поставка сложных, дефицитных, либо снятых с производства позиций;
- Оперативные сроки поставки под заказ (от 5 рабочих дней);
- Экспресс доставка в любую точку России;
- Техническая поддержка проекта, помощь в подборе аналогов, поставка прототипов;
- Система менеджмента качества сертифицирована по Международному стандарту ISO 9001;
- Лицензия ФСБ на осуществление работ с использованием сведений, составляющих государственную тайну;
- Поставка специализированных компонентов (Xilinx, Altera, Analog Devices, Intersil, Interpoint, Microsemi, Aeroflex, Peregrine, Syfer, Eurofarad, Texas Instrument, Miteq, Cobham, E2V, MA-COM, Hittite, Mini-Circuits, General Dynamics и др.);

Помимо этого, одним из направлений компании «ЭлектроПласт» является направление «Источники питания». Мы предлагаем Вам помощь Конструкторского отдела:

- Подбор оптимального решения, техническое обоснование при выборе компонента;
- Подбор аналогов;
- Консультации по применению компонента;
- Поставка образцов и прототипов;
- Техническая поддержка проекта;
- Защита от снятия компонента с производства.



Как с нами связаться

Телефон: 8 (812) 309 58 32 (многоканальный)

Факс: 8 (812) 320-02-42

Электронная почта: org@eplast1.ru

Адрес: 198099, г. Санкт-Петербург, ул. Калинина, дом 2, корпус 4, литера А.