

Jul.1.2019 Copyright 2019 HIROSE ELECTRIC CO., LTD. All Rights Reserved.  
 In case of consideration for using Automotive equipment / device which demand high reliability, kindly contact our sales window correspondents.

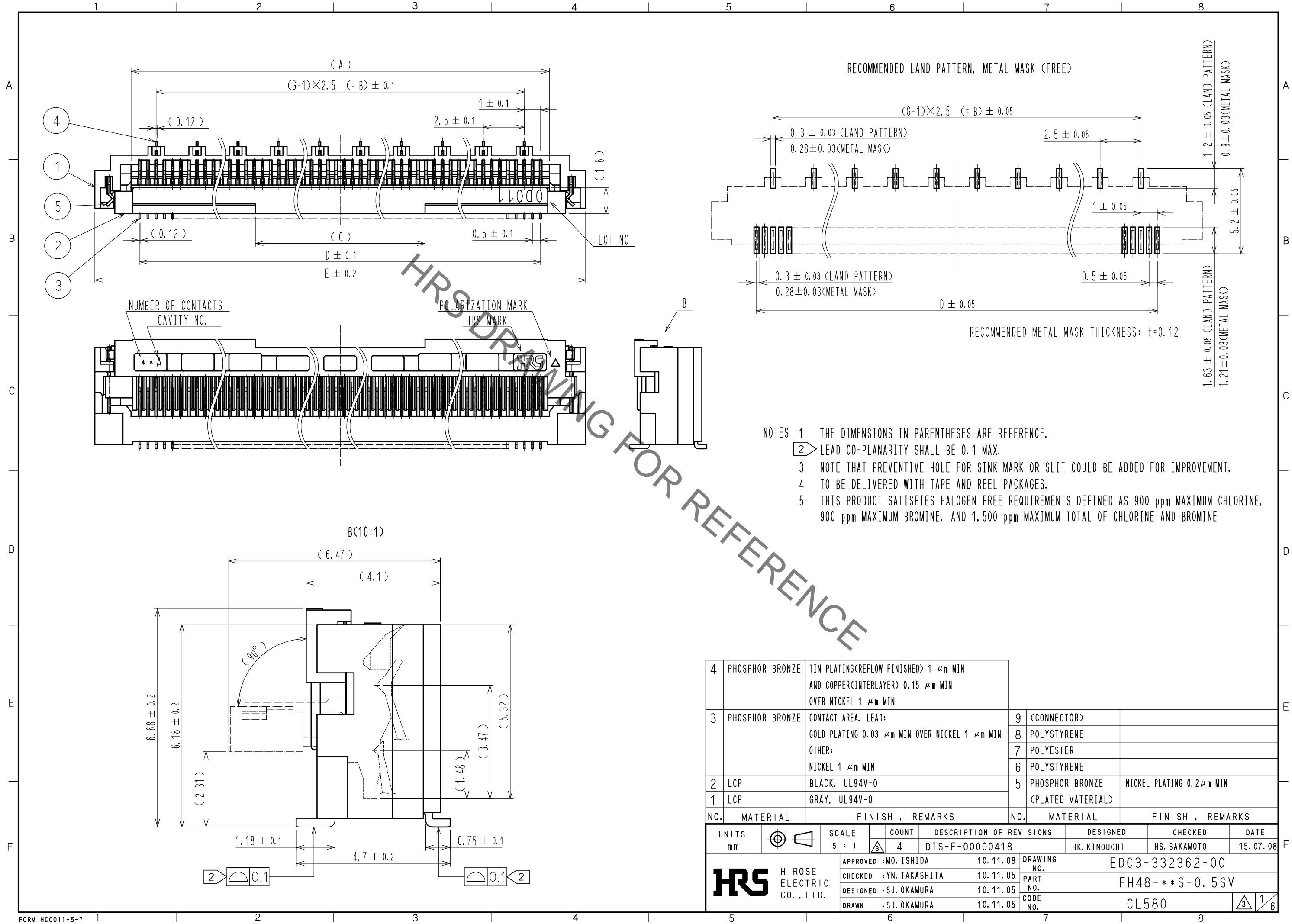

4	PHOSPHOR BRONZE	TIN PLATING(REFLOW FINISHED) 1 μm MIN AND COPPER(INTERLAYER) 0.15 μm MIN OVER NICKEL 1 μm MIN					
3	PHOSPHOR BRONZE	CONTACT AREA, LEAD: GOLD PLATING 0.03 μm MIN OVER NICKEL 1 μm MIN OTHER: NICKEL 1 μm MIN	9 (CONNECTOR)				
2	LCP	BLACK, UL94V-0	8 POLYSTYRENE				
1	LCP	GRAY, UL94V-0	7 POLYESTER				
			6 POLYSTYRENE				
			5 PHOSPHOR BRONZE (PLATED MATERIAL)				NICKEL PLATING 0.2 μm MIN
NO.	MATERIAL	FINISH . REMARKS	NO.	MATERIAL	FINISH . REMARKS		
UNITS	mm	SCALE	5 : 1	COUNT	4	DESCRIPTION OF REVISIONS	DIS-F-00000418
		DESIGNED	HK. KINOUCHI	CHECKED	HS. SAKAMOTO	DATE	15.07.08
		APPROVED	MO. ISHIDA	10.11.08	DRAWING NO.	EDC3-332362-00	
		CHECKED	YN. TAKASHITA	10.11.05	PART NO.	FH48-**S-0.5SV	
		DESIGNED	SJ. OKAMURA	10.11.05	CODE NO.	CL580	
		DRAWN	SJ. OKAMURA	10.11.05			

Jul.1.2019 Copyright 2019 HIROSE ELECTRIC CO., LTD. All Rights Reserved.  
 In case of consideration for using Automotive equipment / device which demand high reliability, kindly contact our sales window correspondents.

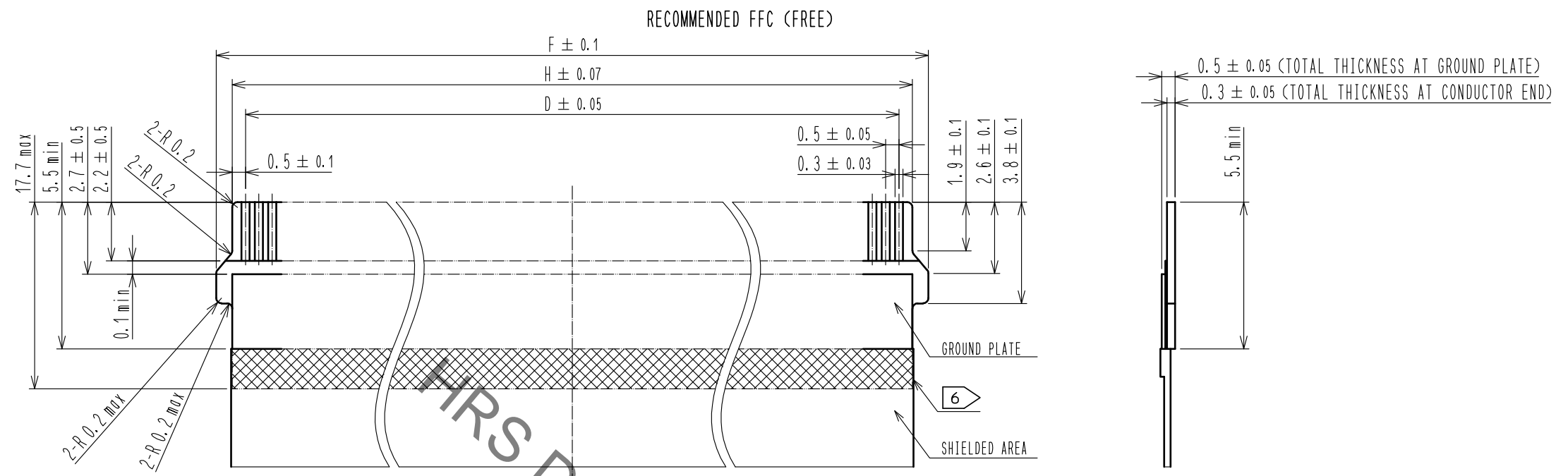

FFC CONSTRUCTION (RECOMMENDED SPECIFICATIONS)

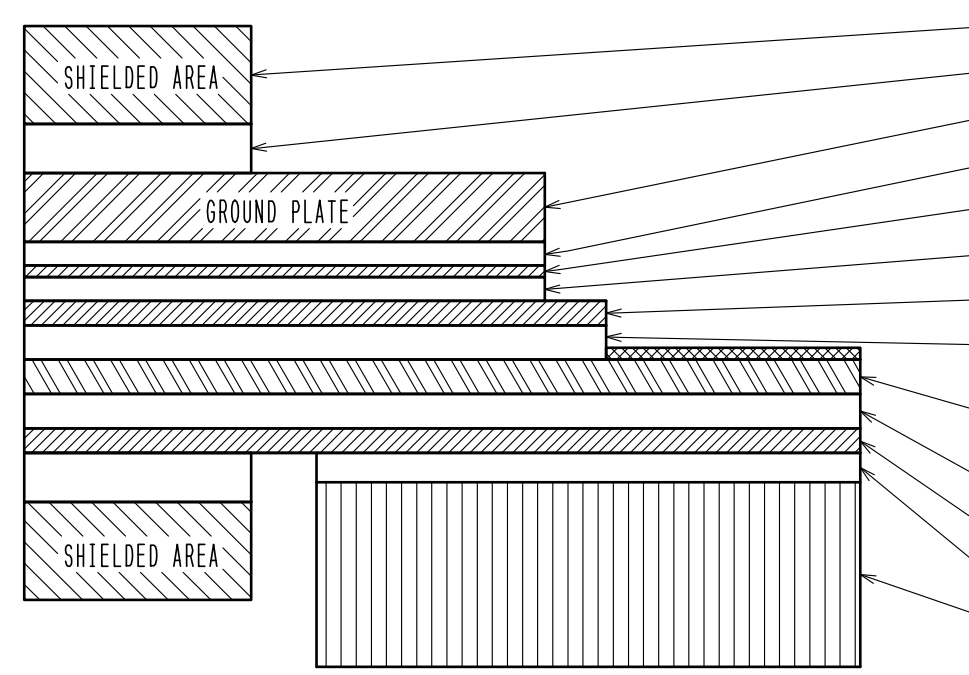

MATERIAL NAME	MATERIAL	TOTAL THICKNESS AT GROUND PLATE (μm)	TOTAL THICKNESS AT CONDUCTOR END (μm)
SHIELDING MATERIAL			
CONDUCTIVE ADHESIVE	POLYESTER TYPE		
COPPER FILM (TIN PLATED)		70	70
ADHESIVE	ACRYLIC TYPE	24	24
BASE MATERIAL	POLYESTER TYPE	12	12
ADHESIVE	ACRYLIC TYPE	24	24
INSULATED LAYER	POLYESTER TYPE	25	25
ADHESIVE	POLYESTER TYPE	35	35
SOFT COPPER FILM (NICKEL UNDER PLATED / GOLD PLATED)		35	35
ADHESIVE	POLYESTER TYPE	35	35
INSULATED LAYER	POLYESTER TYPE	25	25
ADHESIVE	POLYESTER TYPE	30	30
STIFFENER	POLYESTER TYPE	188	188
<b>TOTAL</b>		<b>503</b>	<b>313</b>

- NOTES
- 6 PLEASE OVERLAP SHIELD AREA ON GROUND PLATE.
  - 7 PLEASE INQUIRE OF HIROSE WHEN YOU WANT TO CHANGE THE SPECIFICATION AND THE THICKNESS COMPOSITION IN THIS PART.

<b>HRS</b>	DRAWING NO.	EDC3-332362-00
	PART NO.	FH48-**S-0.5SV
	CODE NO.	CL580

3	2	6
---	---	---

Jul.1.2019 Copyright 2019 HIROSE ELECTRIC CO., LTD. All Rights Reserved.  
 In case of consideration for using Automotive equipment / device which demand high reliability, kindly contact our sales window correspondents.

EMBOSSED CARRIER TAPE DIMENSION (2:1)

TAPE WIDTH: 24

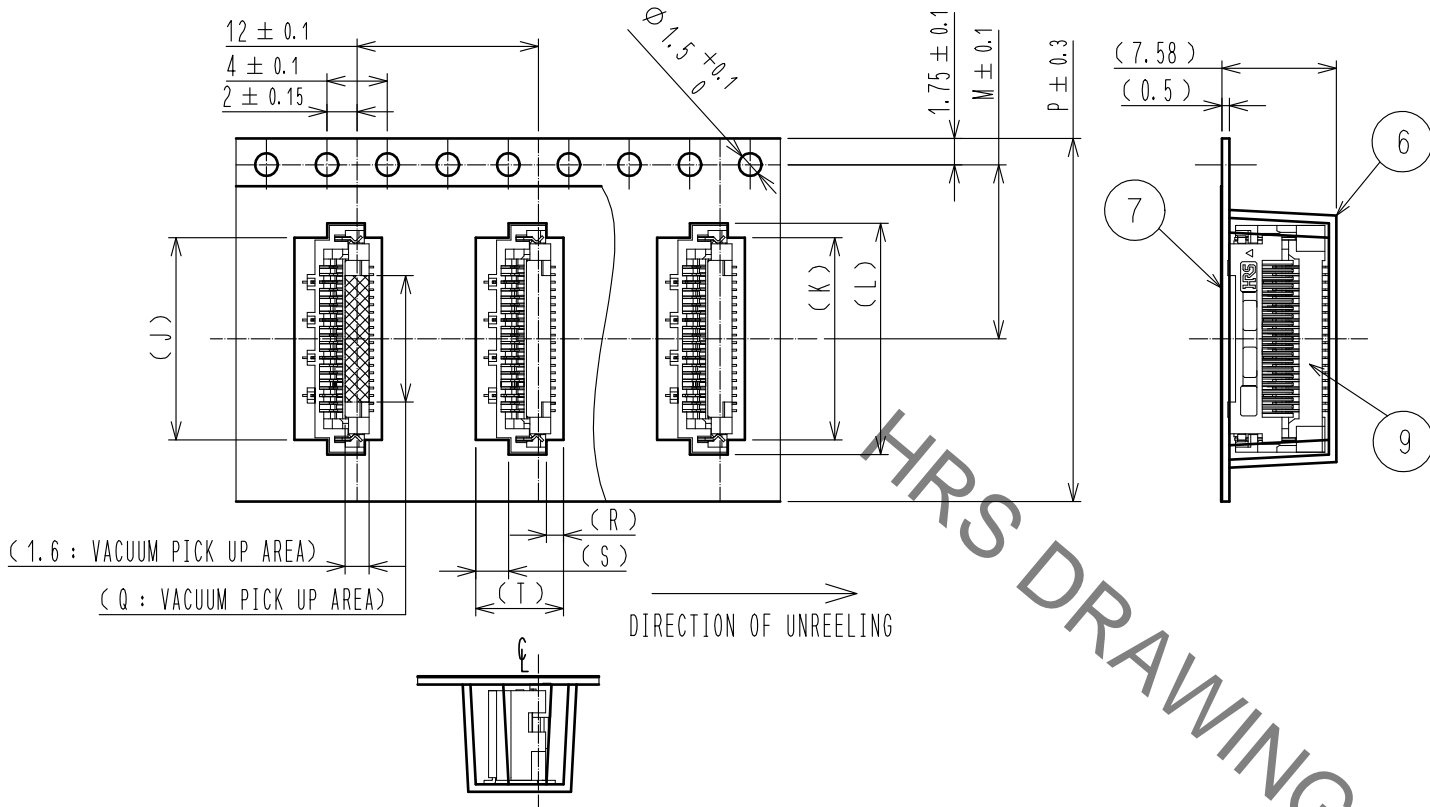

TAPE WIDTH: 32 MIN

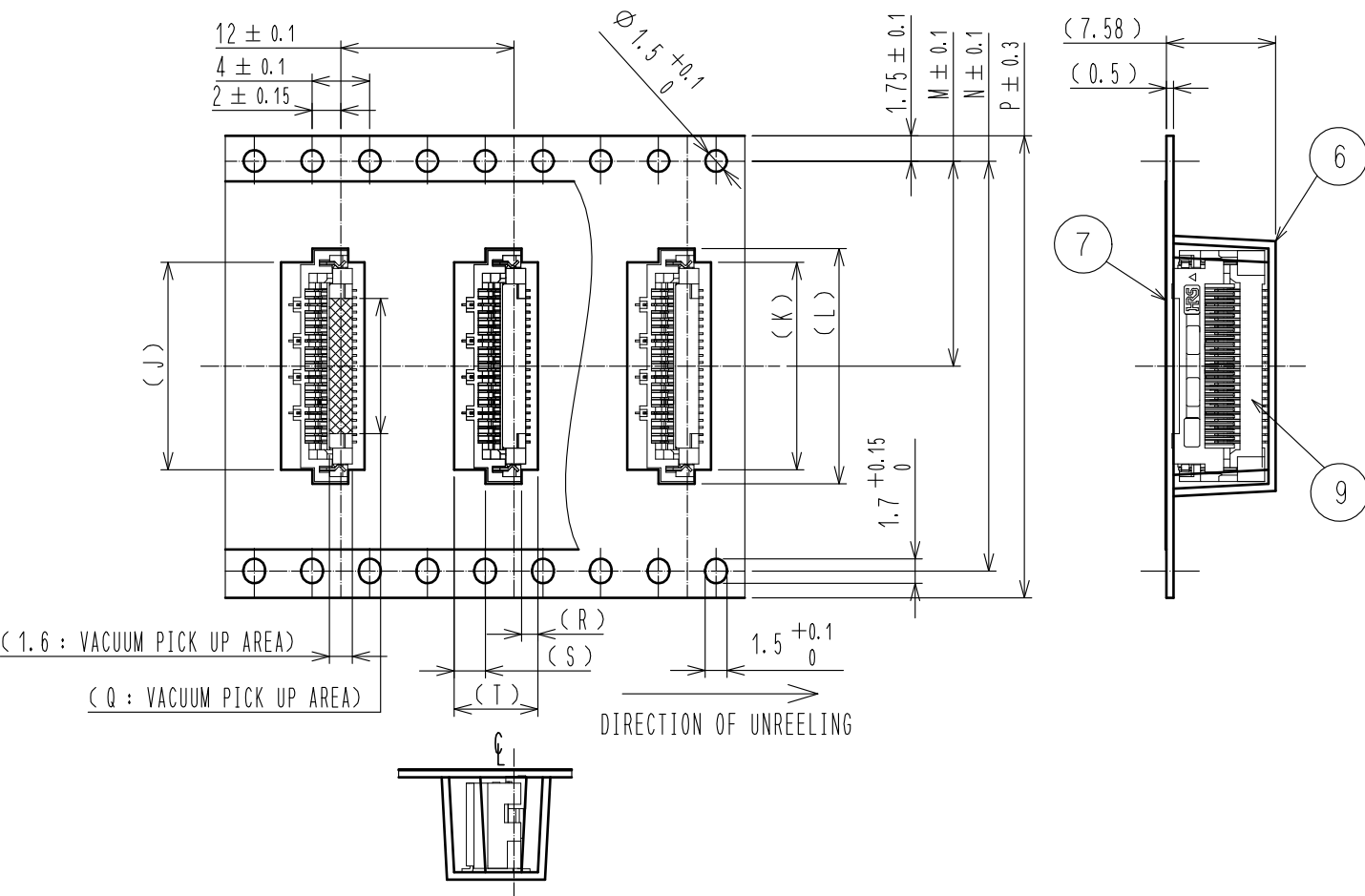

REEL DIMENSION (FREE)

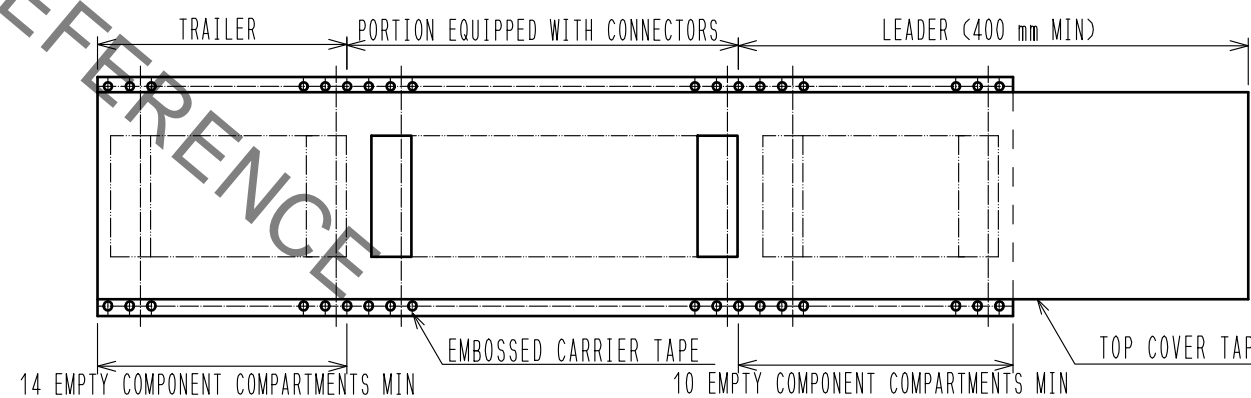
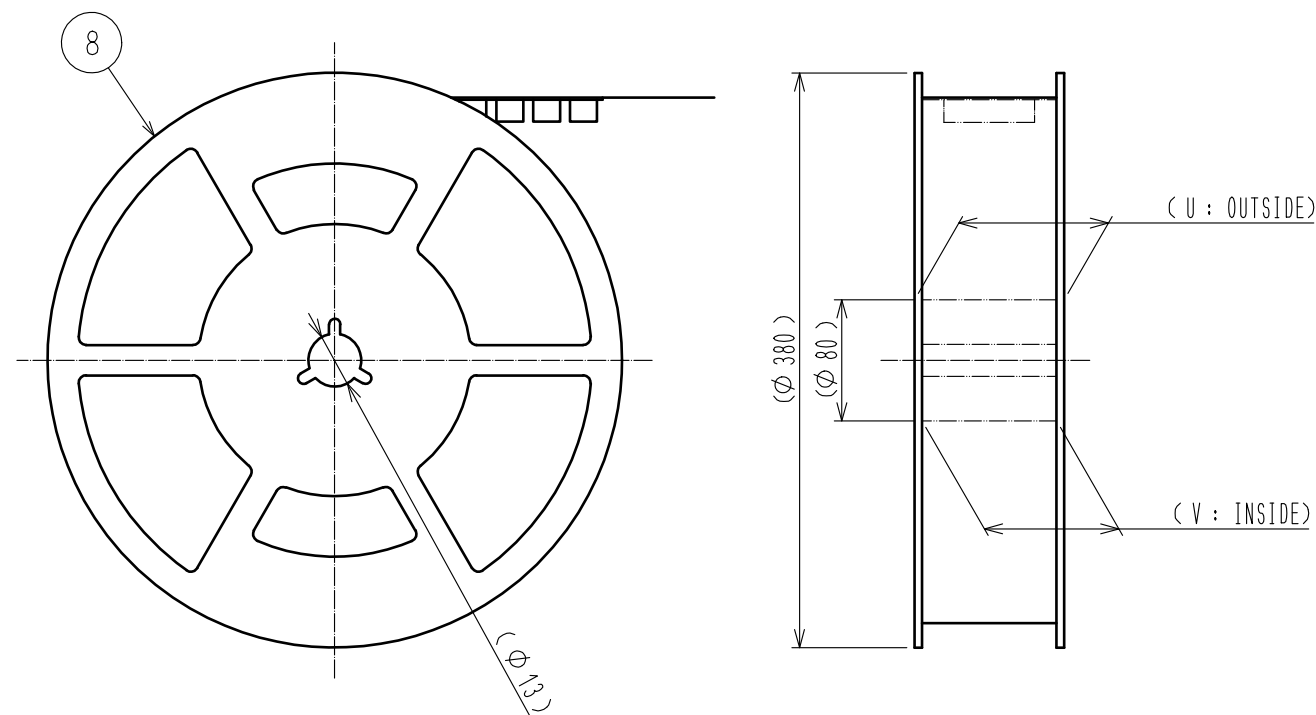

NOTES 8 PER REEL: 1,000 CONNECTORS.  
 9 REFER TO JIS C 0806 (PACKING OF COMPONENTS FOR AUTOMATIC HANDLING.)

<b>HRS</b>	DRAWING NO.	EDC3-332362-00
	PART NO.	FH48-**S-0.5SV
	CODE NO.	CL580
	3/6	

Jul.1.2019 Copyright 2019 HIROSE ELECTRIC CO., LTD. All Rights Reserved.  
 In case of consideration for using Automotive equipment / device which demand high reliability, kindly contact our sales window correspondents.



PART NUMBER	CODE NUMBER	NUMBER OF CONTACTS	NUMBER OF GROUND CONTACTS : G	DIMENSION OF CONNECTOR, LAND PATTERN, METAL MASK AND FFC								DIMENSION OF DRAWING OF PACKING										
				A	B	C	D	E	F	H	J	K	L	M	N	P	Q	R	S	T	U	V
FH48-20S-0.5SV	CL580-3104-1-00	20	4	10.57	7.5	8.37	9.5	15	11.7	10.5	13.37	13.37	15.3	11.5	-	24	8.37	1.33	2.17	5.8	29.4	25.4
FH48-21S-0.5SV	CL580-3103-9-00	21	4	11.07	7.5	8.87	10	15.5	12.2	11	13.87	13.87	15.8	11.5	-	24	8.87	1.33	2.17	5.8	29.4	25.4
FH48-30S-0.5SV	CL580-3106-7-00	30	6	15.57	12.5	10.37	14.5	20	16.7	15.5	15.07	15.93	20.3	20.2	40.4	44	10.37	1.16	1.37	6.08	49.4	45.4
FH48-31S-0.5SV	CL580-3102-6-00	31	6	16.07	12.5	10.37	15	20.5	17.2	16	18.87	18.87	20.8	20.2	40.4	44	10.37	1.33	2.17	5.8	49.4	45.4
FH48-40S-0.5SV	CL580-3100-0-00	40	8	20.57	17.5	10.37	19.5	25	21.7	20.5	23.37	23.37	25.3	20.2	40.4	44	10.37	1.33	2.17	5.8	49.4	45.4
FH48-50S-0.5SV	CL580-3101-3-00	50	10	25.57	22.5	10.37	24.5	30	26.7	25.5	28.37	28.37	30.3	20.2	40.4	44	10.37	1.33	2.17	5.8	49.4	45.4
FH48-68S-0.5SV	CL580-3105-4-00	68	13	34.57	30	10.37	33.5	39	35.7	34.5	37.37	37.37	39.3	26.2	52.4	56	10.37	1.33	2.17	5.8	61.4	57.4

NOTES 10 PLEASE CONTACT HIROSE FOR DETAILED INFORMATION ABOUT PRODUCT VARIATION.

HIROSE ELECTRIC CO., LTD.  
 DRAWING FOR REFERENCE

<b>HRS</b>	DRAWING NO.	EDC3-332362-00	
	PART NO.	FH48-**S-0.5SV	
	CODE NO.	CL580	

Jul.1.2019 Copyright 2019 HIROSE ELECTRIC CO., LTD. All Rights Reserved.  
In case of consideration for using Automotive equipment / device which demand high reliability, kindly contact our sales window correspondents.

This connector requires delicate and careful handling.  
Read through the instructions shown below and handle the connector properly.  
Each values indicating here are for reference and may differ from standard value.

### [ INSTRUCTIONS FOR MOUNTING ON THE BOARD ]

#### ◆Warp of Board

Minimize warp of the board as much as possible.  
Lead co-planarity is 0.1 mm or less.  
Too much warp of the board may result in a soldering failure.

#### ◆Load to Connector

Do not add 1N or greater external force when unreel or pick and place the connector etc.  
or it may get broken.  
In addition, do not insert the FFC or operate the connector before mounting it.

### [ INSTRUCTIONS FOR PCB HANDLING AFTER MOUNTING THE CONNECTOR ]

#### ◆Load to Board

- Splitting a large board into several pieces  
- Screwing the board  
Avoid the handling described above so that no force is exerted on the board during the assembly process.  
Otherwise, the connector may become defective.

#### ◆Amount of Warp

The warp of a 100 mm wide board should be 1 mm or less.  
The warp of board suffers stress on connector and the connector may become defective.

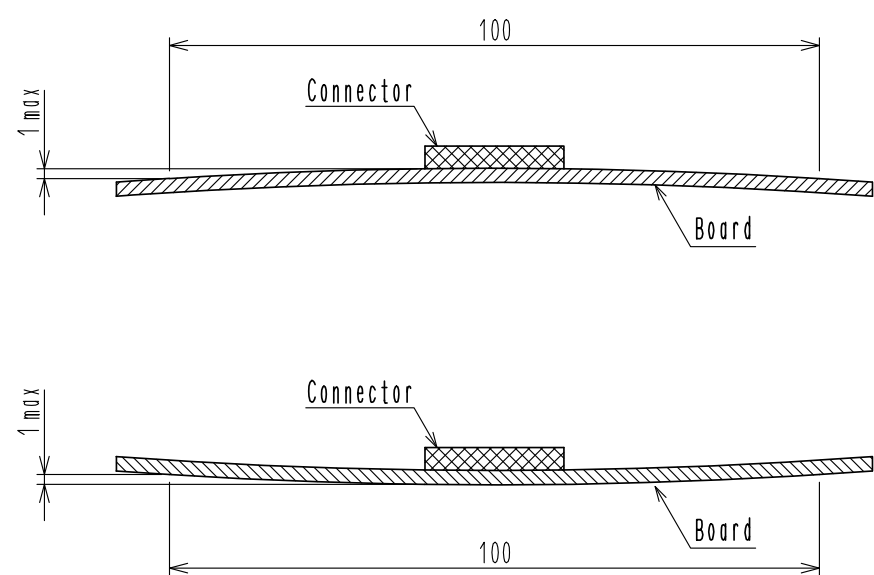

### [ INSTRUCTIONS ON INSERTING FFC AND CONNECTION ]

#### ◆Actuator position

Actuator position as delivered is ready for FFC insertion.  
FFC locked position is that the FFC is inserted and the actuator is rotated by 90° .  
Do not rotate the actuator before FFC is inserted.

#### ◆Direction of contacts

Insert the FFC in a way that the FFC circuit exposed side faces to the housing,  
and FFC stiffener side to the actuator.

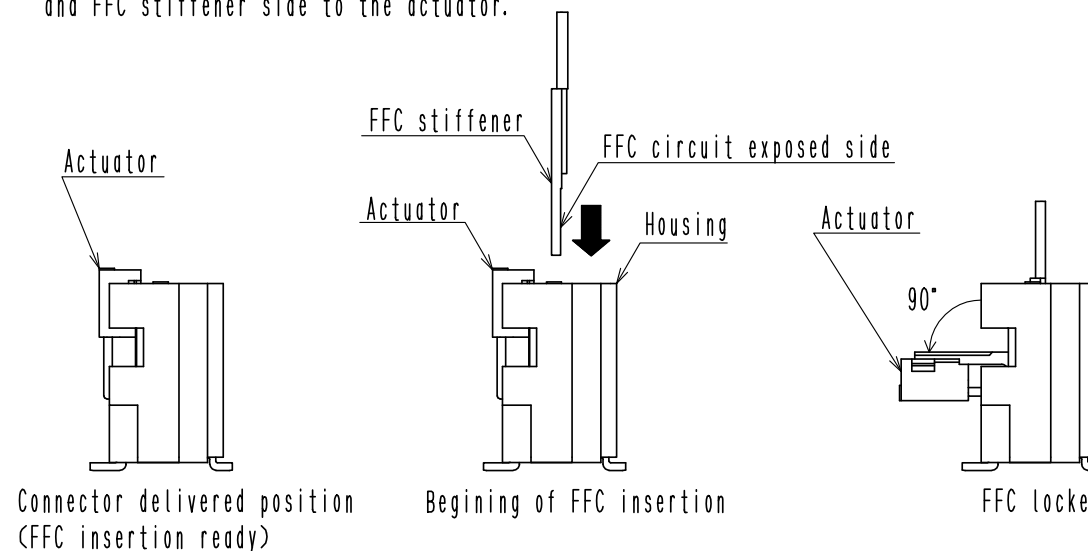

#### ◆Inserting the FFC

Insert the FFC at a right angle to the connector and properly to the very end.

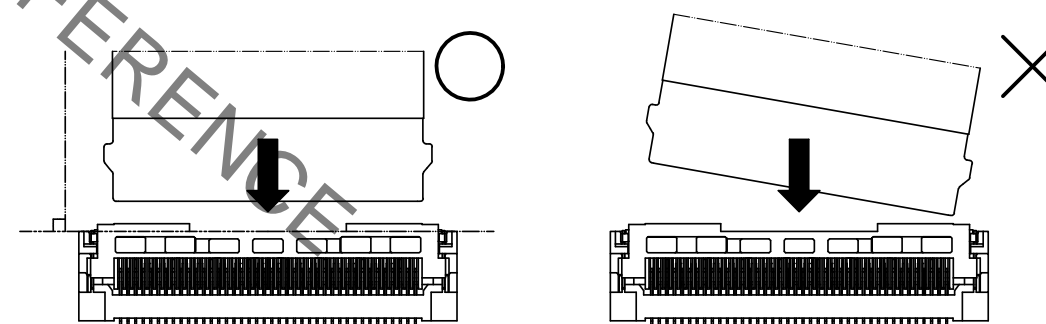

< INSTRUCTION MANUAL (1) >

**HRS**

DRAWING NO.	EDC3-332362-00
PART NO.	FH48-**S-0.5SV
CODE NO.	CL580

3/5/6

Jul.1.2019 Copyright 2019 HIROSE ELECTRIC CO., LTD. All Rights Reserved.  
 In case of consideration for using Automotive equipment / device which demand high reliability, kindly contact our sales window correspondents.

◆Use of the actuator

1. The actuator rotates around the rotational axis as shown below. Rotate the actuator.
2. The actuator will not open more than 90°. Do not apply any force backward beyond this point. It may cause contact deformation and actuator breakage.
3. Do not pinch or pick the actuator to lift it as shown below. Otherwise, it may break. (Do not carry out any operation other than rotating the actuator as shown above.)

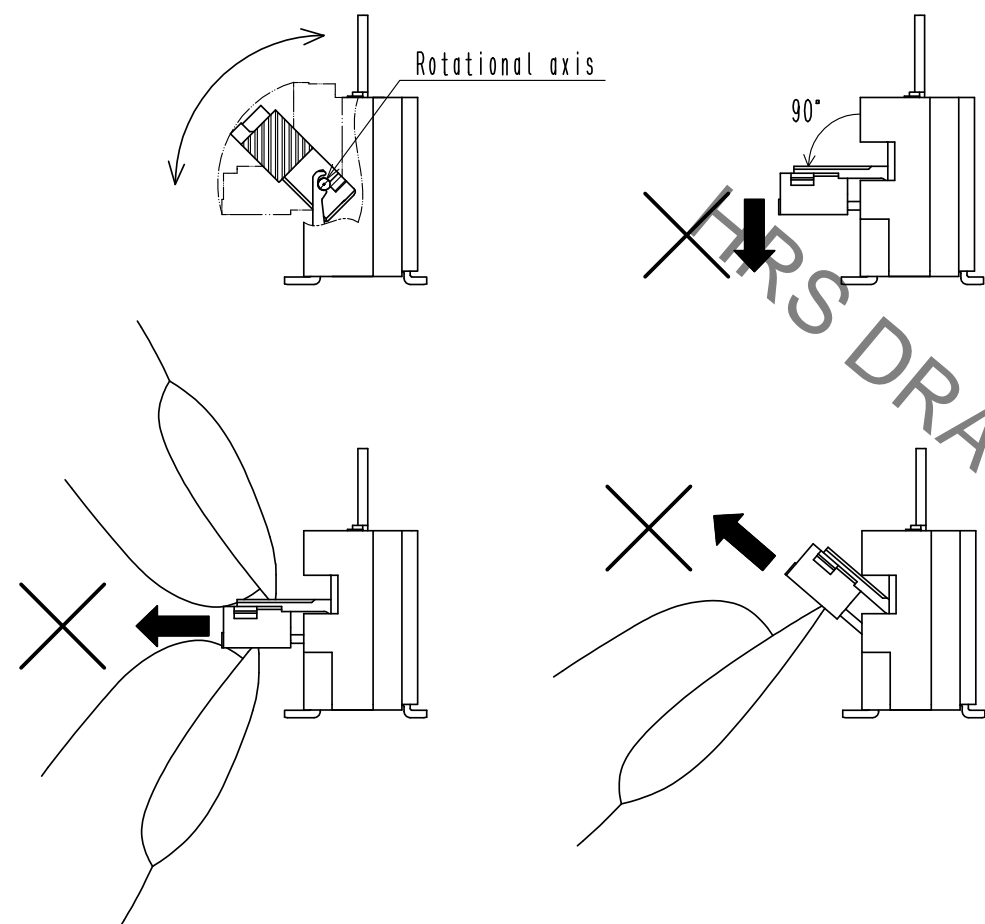

◆Checking the Locking Condition

1. In the locked condition, make sure that the actuator is horizontal on the board surface.
2. After FFC is locked, make sure the position of TAB and guides.

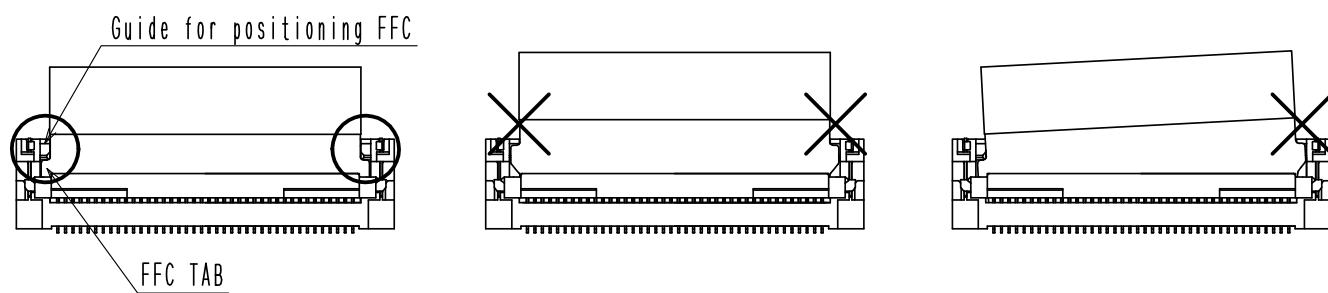

[ INSTRUCTION ON FFC LAYOUT CONNECTION ]

◆Load to FFC

Be very careful not to apply force to the connector directly after inserting FFC. Otherwise, the connector or the FFC may break. In particular, design the FFC layout with care not to bend it sharply in a direction of the actuator side near the insertion operating.

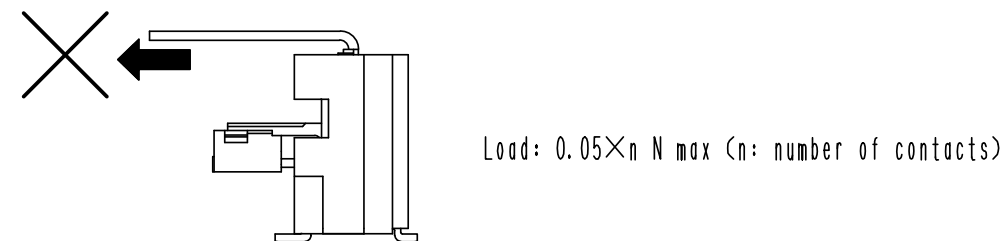

[ INSTRUCTIONS ON REMOVING FFC ]

- ◆For FFC removal, remove the FFC after unlocking the actuator. Remove the FFC by about 7 degrees perpendicular to PCB.

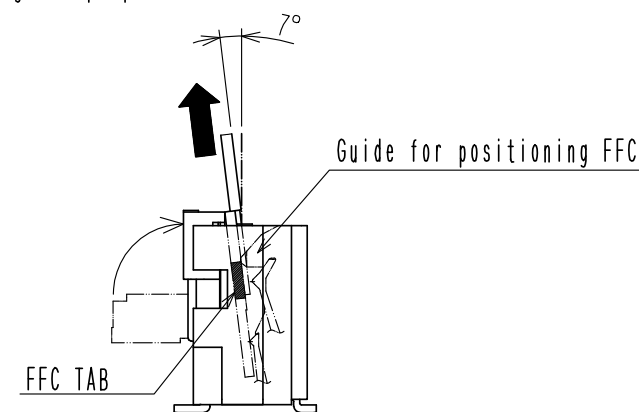

[ OTHER INSTRUCTIONS ]

◆Instructions on Manual Soldering

Follow the instructions shown below when soldering the connector manually during repair work, etc.

1. Do not perform reflow soldering or manual soldering with the FFC inserted into the connector.
2. Do not heat the connector excessively. Be very careful not to let the soldering iron contact any parts other than connector leads. Otherwise, the connector may be deformed or melt.
3. Do not use excessive solder (or flux). If excessive solder (or flux) is used on the terminals, solder or flux may adhere to the contacts or rotating parts of the actuator, resulting in poor contact or a rotation failure of the actuator.

< INSTRUCTION MANUAL (2) >

<b>HRS</b>	DRAWING NO.	EDC3-332362-00	3/6
	PART NO.	FH48-**S-0.5SV	
	CODE NO.	CL580	



Компания «ЭлектроПласт» предлагает заключение долгосрочных отношений при поставках импортных электронных компонентов на взаимовыгодных условиях!

Наши преимущества:

- Оперативные поставки широкого спектра электронных компонентов отечественного и импортного производства напрямую от производителей и с крупнейших мировых складов;
- Поставка более 17-ти миллионов наименований электронных компонентов;
- Поставка сложных, дефицитных, либо снятых с производства позиций;
- Оперативные сроки поставки под заказ (от 5 рабочих дней);
- Экспресс доставка в любую точку России;
- Техническая поддержка проекта, помощь в подборе аналогов, поставка прототипов;
- Система менеджмента качества сертифицирована по Международному стандарту ISO 9001;
- Лицензия ФСБ на осуществление работ с использованием сведений, составляющих государственную тайну;
- Поставка специализированных компонентов (Xilinx, Altera, Analog Devices, Intersil, Interpoint, Microsemi, Aeroflex, Peregrine, Syfer, Eurofarad, Texas Instrument, Miteq, Cobham, E2V, MA-COM, Hittite, Mini-Circuits, General Dynamics и др.);

Помимо этого, одним из направлений компании «ЭлектроПласт» является направление «Источники питания». Мы предлагаем Вам помощь Конструкторского отдела:

- Подбор оптимального решения, техническое обоснование при выборе компонента;
- Подбор аналогов;
- Консультации по применению компонента;
- Поставка образцов и прототипов;
- Техническая поддержка проекта;
- Защита от снятия компонента с производства.



#### Как с нами связаться

**Телефон:** 8 (812) 309 58 32 (многоканальный)

**Факс:** 8 (812) 320-02-42

**Электронная почта:** [org@eplast1.ru](mailto:org@eplast1.ru)

**Адрес:** 198099, г. Санкт-Петербург, ул. Калинина, дом 2, корпус 4, литера А.