

Description

IS31FL3236/IS31FL3236A is comprised of 36 constant current channels each with independent PWM control, designed for driving LEDs. The output current of each channel can be set at up to 38mA (Max.) by an external resistor and independently scaled by a factor of 1, 1/2, 1/3 and 1/4. The average LED current of each channel can be changed in 256 steps by changing the PWM duty cycle through an I2C interface.

Features

- 2.7V to 5.5V supply
- I2C interface, automatic address increment function
- Internal reset register
- Modulate LED brightness with 256 steps PWM
- Each channel can be controlled independently
- Each channel can be scaled independently by
- QFN-44 (5mm × 5mm) package

Quick Start



Figure 1: Photo of IS31FL3236/IS31FL3236A Evaluation Board

Recommended Equipment

- 5.0V, 2A power supply

Absolute Maximum Ratings

- $\leq 5.5V$ power supply

Caution: Do not exceed the conditions listed above, otherwise the board will be damaged.

Procedure

The IS31FL3236/IS31FL3236A evaluation board is fully assembled and tested. Follow the steps listed below to verify board operation.

Caution: Do not turn on the power supply until all connections are completed.

- 1) Connect the ground terminal of the power supply to the GND and the positive terminal to the VCC. Or connect the DC power to the connector (DC IN).
- 2) Turn on the power supply and pay attention to the supply current. If the current exceeds 1.2A, please check for circuit fault.
- 3) Enter the desired mode of display by toggling the MODE button.

Evaluation Board Ordering Information

Part No.	Package
IS31FL3236-QFLS2-EB	QFN-44, Lead-free
IS31FL3236A-QFLS2-EB	QFN-44, Lead-free

Table1: Ordering Information

For pricing, delivery, and ordering information, please contacts ISSI's analog marketing team at analog_mkt@issi.com or (408) 969-6600.

Evaluation Board Operation

The IS31FL3236/IS31FL3236A evaluation board has six display modes. Press MODE button to switch configurations.

- 1) (Default mode) The 12 RGB LEDs in the middle of the board show a color changing light bar moving pattern.
- 2) Two groups of blue LED on above display a tailing effect move from right to left.
- 3) Two groups of blue LED on above display a tailing effect move in opposite directions.
- 4) Blue LED on above perform timer display.
- 5) Two groups of blue LED on above flash together from two sides to middle and then turn off slowly from both sides to middle.
- 6) The blue LEDs on above are put into four '8' digits and to show a twist effect.

***Note:**

IS31FL3236/IS31FL3236A solely controls the FxLED function on the evaluation board.

Software support

JP1 default setting is close circuit. If it is set to open, the on-board MCU will stop working. The I2C pins are set to High Impedance. External I2C signals can be connected to TP3 to control the IS31FL3236 LED driver.

Please refer to the datasheet to get more information about IS31FL3236/IS31FL3236A.

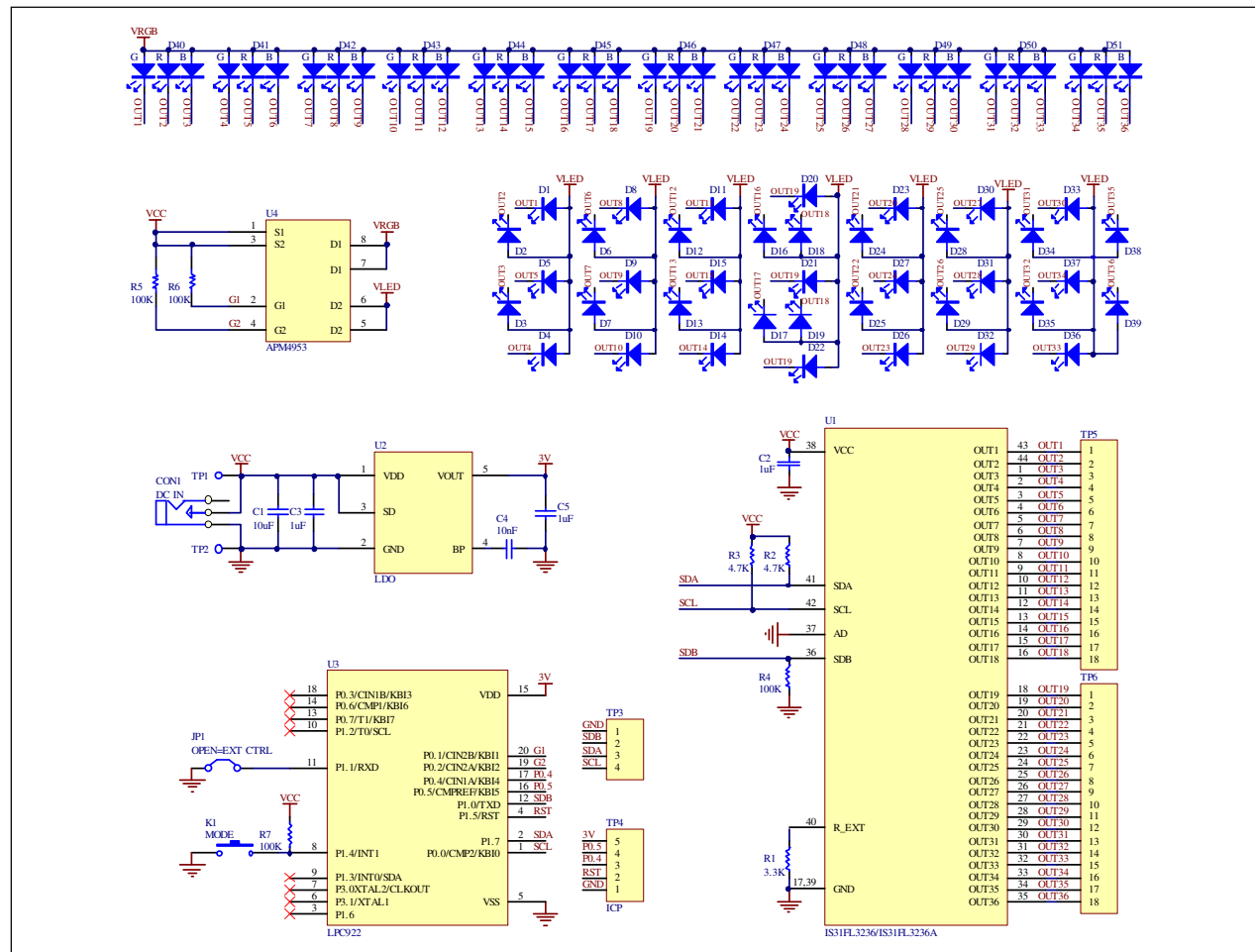

Figure 2: IS31FL3236/IS31FL3236A Application Schematic

Bill of Materials

Name	Symbol	Description	Qty	Supplier	Part No.
LED Driver	U1	36 CH FxLED Driver	1	ISSI	IS31FL3236/IS31FL3236A
LDO	U2	Low-dropout Regulator	1	PAM	PAM3101
MCU	U3	Microcontroller	1	NXP	LPC922
PMOS	U4	Dual PMOS	1	ANPEC	APM4953
Diode	D1~D39	Diode, LED Blue, SMD	39	Everlight	19-217/BHC-ZL1M2RY/3T
Diode	D40~D51	Diode, LED RGB, SMD	12	Everlight	99-235/RGBC/TR8
Resistor	R1	RES,3.3k,1/16W,±5%,SMD	1	Yageo	RC0603JR-073K3L
Resistors	R2~R3	RES,4.7k,1/16W,±5%,SMD	2	Yageo	RC0603JR-074K7L
Resistors	R4~R7	RES,100k,1/16W,±5%,SMD	4	Yageo	RC0603JR-07100KL
Capacitor	C1	CAP,10μF,16V,±20%,SMD	1	Yageo	CC0603KKX7R9BB106
Capacitors	C2,C3,C5	CAP, 1μF,16V,±20%,SMD	3	Yageo	CC0603KKX7R9BB105
Capacitor	C4	CAP,10nF,16V,±20%,SMD	1	Yageo	CC0603KKX7R9BB103
Button	K1	Button SMD	1		

Table 2: Bill of Materials, refer to Figure 2 above.

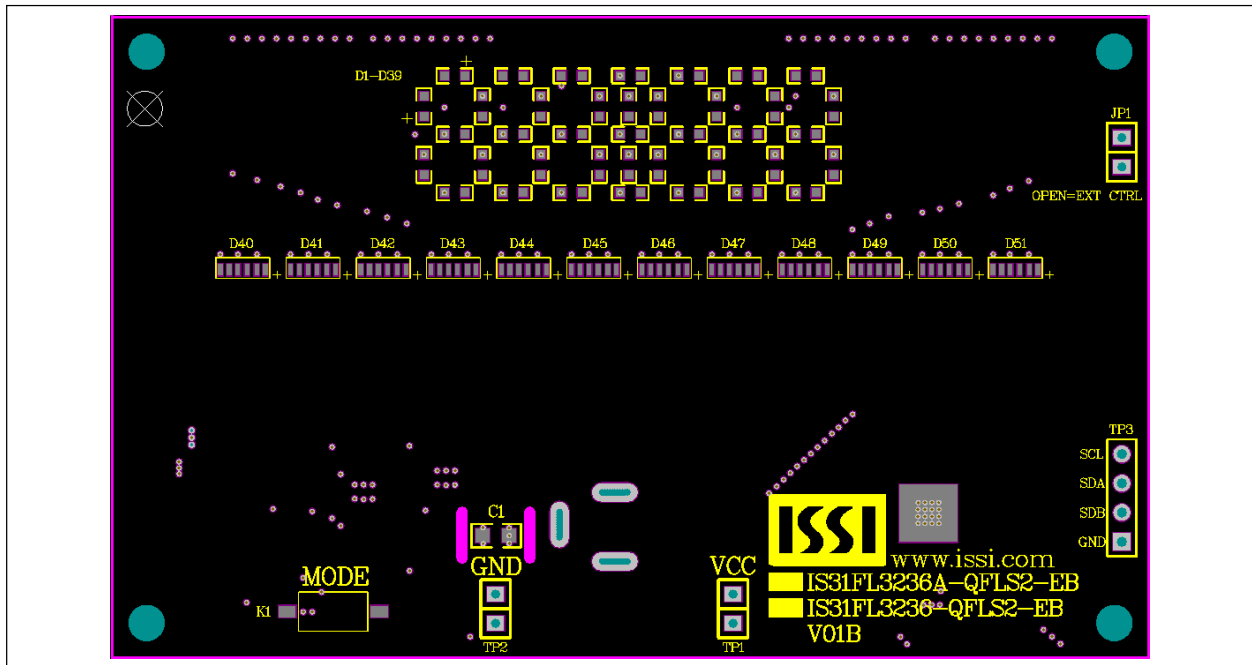

Figure 3: Board Component Placement Guide - Top Layer

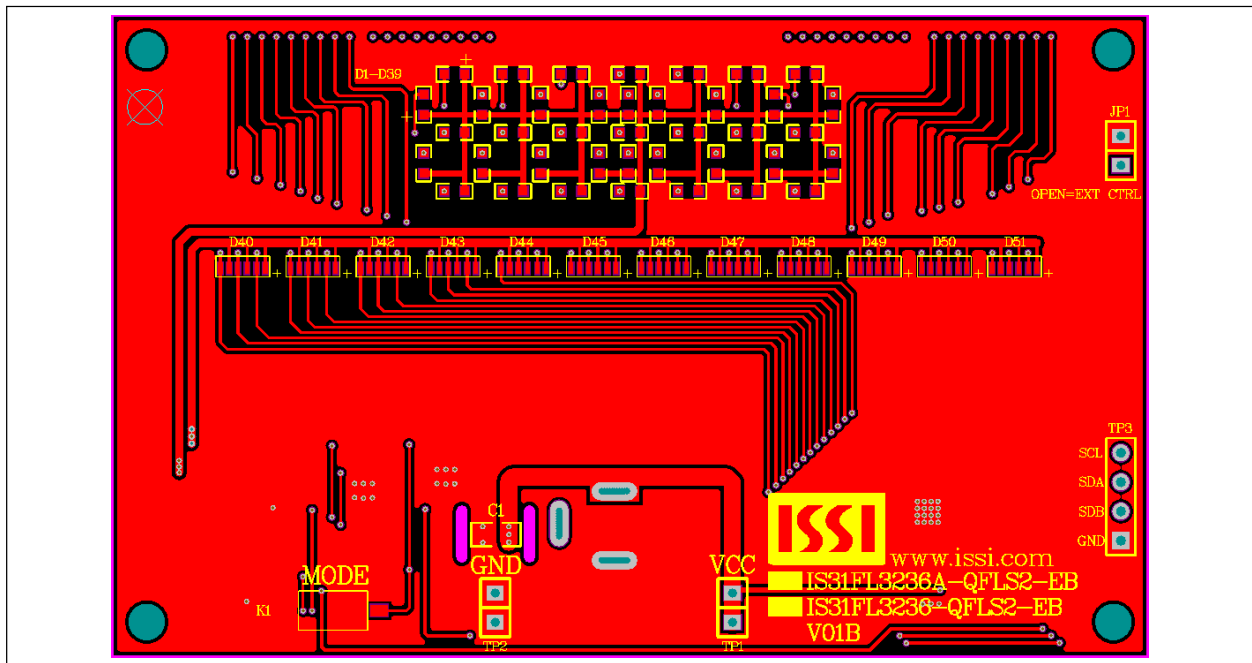

Figure 4: Board PCB Layout- Top Layer

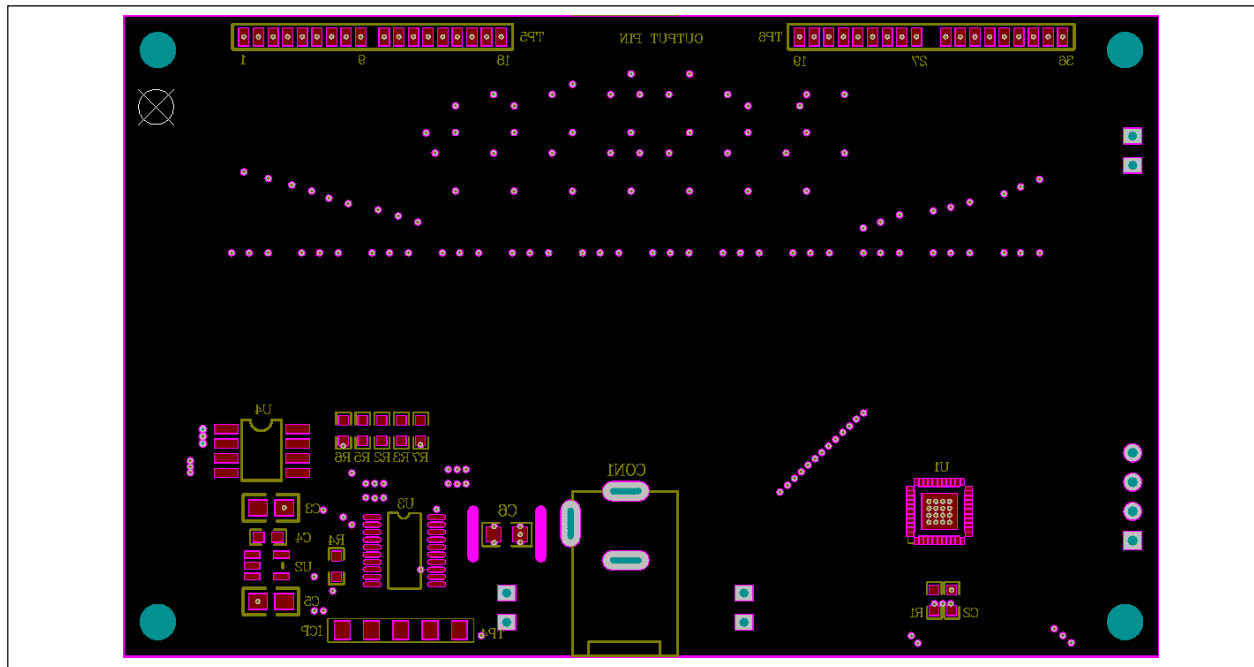

Figure 5: Board Component Placement Guide -Bottom Layer

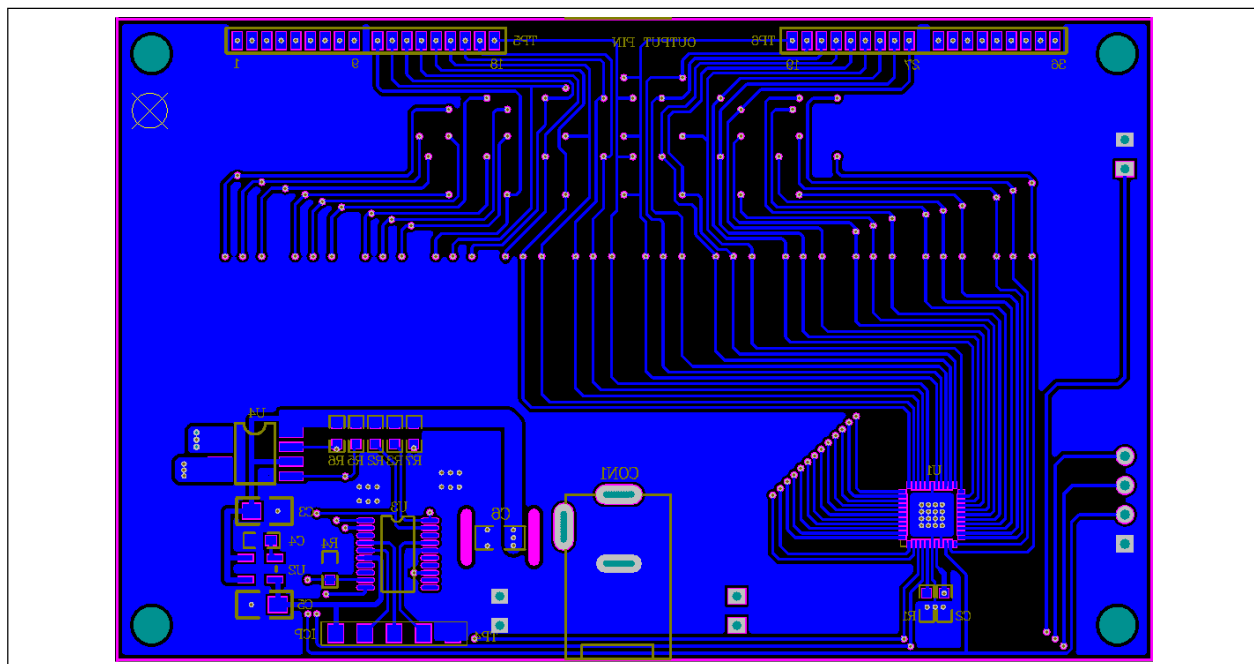

Figure 6: Board PCB Layout-Bottom Layer



REVISION HISTORY

Revision	Detail Information	Data
A	Initial Release	2016.11.18

Copyright © 2016 Integrated Silicon Solution, Inc. All rights reserved. ISSI reserves the right to make changes to this specification and its products at any time without notice. ISSI assumes no liability arising out of the application or use of any information, products or services described herein. Customers are advised to obtain the latest version of this device specification before relying on any published information and before placing orders for products.

Integrated Silicon Solution, Inc. does not recommend the use of any of its products in life support applications where the failure or malfunction of the product can reasonably be expected to cause failure of the life support system or to significantly affect its safety or effectiveness. Products are not authorized for use in such applications unless Integrated Silicon Solution, Inc. receives written assurance to its satisfaction, that:

- a.) the risk of injury or damage has been minimized;
- b.) the user assume all such risks; and
- c.) potential liability of Integrated Silicon Solution, Inc is adequately protected under the circumstances



Компания «ЭлектроПласт» предлагает заключение долгосрочных отношений при поставках импортных электронных компонентов на взаимовыгодных условиях!

Наши преимущества:

- Оперативные поставки широкого спектра электронных компонентов отечественного и импортного производства напрямую от производителей и с крупнейших мировых складов;
- Поставка более 17-ти миллионов наименований электронных компонентов;
- Поставка сложных, дефицитных, либо снятых с производства позиций;
- Оперативные сроки поставки под заказ (от 5 рабочих дней);
- Экспресс доставка в любую точку России;
- Техническая поддержка проекта, помощь в подборе аналогов, поставка прототипов;
- Система менеджмента качества сертифицирована по Международному стандарту ISO 9001;
- Лицензия ФСБ на осуществление работ с использованием сведений, составляющих государственную тайну;
- Поставка специализированных компонентов (Xilinx, Altera, Analog Devices, Intersil, Interpoint, Microsemi, Aeroflex, Peregrine, Syfer, Eurofarad, Texas Instrument, Miteq, Cobham, E2V, MA-COM, Hittite, Mini-Circuits, General Dynamics и др.);

Помимо этого, одним из направлений компании «ЭлектроПласт» является направление «Источники питания». Мы предлагаем Вам помощь Конструкторского отдела:

- Подбор оптимального решения, техническое обоснование при выборе компонента;
- Подбор аналогов;
- Консультации по применению компонента;
- Поставка образцов и прототипов;
- Техническая поддержка проекта;
- Защита от снятия компонента с производства.



Как с нами связаться

Телефон: 8 (812) 309 58 32 (многоканальный)

Факс: 8 (812) 320-02-42

Электронная почта: org@eplast1.ru

Адрес: 198099, г. Санкт-Петербург, ул. Калинина, дом 2, корпус 4, литера А.