



Complete Quad, 14-Bit, High Accuracy, Serial Input, Bipolar Voltage Output DAC

Data Sheet

AD5744R

FEATURES

- Complete quad, 14-bit digital-to-analog converter (DAC)
- Programmable output range: ± 10 V, ± 10.2564 V, or ± 10.5263 V
- ± 1 LSB maximum INL error, ± 1 LSB maximum DNL error
- Low noise: 60 nV/ $\sqrt{\text{Hz}}$
- Settling time: 10 μs maximum
- Integrated reference buffers
- Internal reference: 10 ppm/ $^{\circ}\text{C}$ maximum
- On-chip die temperature sensor
- Output control during power-up/brownout
- Programmable short-circuit protection
- Simultaneous updating via LDAC
- Asynchronous CLR to zero code
- Digital offset and gain adjust
- Logic output control pins
- DSP-/microcontroller-compatible serial interface
- Temperature range: -40°C to $+85^{\circ}\text{C}$
- iCMOS process technology

APPLICATIONS

- Industrial automation
- Open-loop/closed-loop servo control
- Process control
- Data acquisition systems
- Automatic test equipment
- Automotive test and measurement
- High accuracy instrumentation

GENERAL DESCRIPTION

The AD5744R is a quad, 14-bit, serial input, bipolar voltage output DAC that operates from supply voltages of ± 11.4 V to ± 16.5 V. Nominal full-scale output range is ± 10 V. The AD5744R provides integrated output amplifiers, reference buffers, and proprietary power-up/power-down control circuitry. The part also features a digital I/O port, programmed via the serial interface, and an analog temperature sensor. The part incorporates digital offset and gain adjust registers per channel.

The AD5744R is a high performance converter that provides guaranteed monotonicity, integral nonlinearity (INL) of ± 1 LSB, low noise, and 10 μs settling time. The AD5744R includes an on-chip 5 V reference with a reference temperature coefficient of 10 ppm/ $^{\circ}\text{C}$ maximum. During power-up when the supply voltages are changing, VOUTx is clamped to 0 V via a low impedance path.

The AD5744R is based on the iCMOS[®] technology platform, which is designed for analog systems designers within industrial/instrumentation equipment OEMs who need high performance ICs at higher voltage levels. iCMOS enables the development of analog ICs capable of 30 V and operation at ± 15 V supplies, while allowing reductions in power consumption and package size, coupled with increased ac and dc performance.

The AD5744R uses a serial interface that operates at clock rates of up to 30 MHz and is compatible with DSP and microcontroller interface standards. Double buffering allows the simultaneous updating of all DACs. The input coding is programmable to either twos complement or offset binary formats. The asynchronous clear function clears all DATA registers to either bipolar zero or zero scale, depending on the coding used. The AD5744R is ideal for both closed-loop servo control and open-loop control applications. The AD5744R is available in a 32-lead TQFP and offers guaranteed specifications over the -40°C to $+85^{\circ}\text{C}$ industrial temperature range (see Figure 1 for the functional block diagram).

Rev. E

Information furnished by Analog Devices is believed to be accurate and reliable. However, no responsibility is assumed by Analog Devices for its use, nor for any infringements of patents or other rights of third parties that may result from its use. Specifications subject to change without notice. No license is granted by implication or otherwise under any patent or patent rights of Analog Devices. Trademarks and registered trademarks are the property of their respective owners.

One Technology Way, P.O. Box 9106, Norwood, MA 02062-9106, U.S.A.
Tel: 781.329.4700 www.analog.com
Fax: 781.461.3113 ©2008–2011 Analog Devices, Inc. All rights reserved.

TABLE OF CONTENTS

| | | | |
|--|----|---|----|
| Features | 1 | Registers | 24 |
| Applications | 1 | Function Register | 24 |
| General Description | 1 | Data Register | 25 |
| Revision History | 2 | Coarse Gain Register | 25 |
| Functional Block Diagram | 3 | Fine Gain Register | 25 |
| Specifications | 4 | Design Features | 26 |
| AC Performance Characteristics | 6 | Analog Output Control | 26 |
| Timing Characteristics | 7 | Programmable Short-Circuit Protection | 26 |
| Absolute Maximum Ratings | 10 | Digital I/O Port | 26 |
| Thermal Resistance | 10 | Die Temperature Sensor | 26 |
| ESD Caution | 10 | Local Ground Offset Adjust | 26 |
| Pin Configuration and Function Descriptions | 11 | Applications Information | 27 |
| Typical Performance Characteristics | 13 | Typical Operating Circuit | 27 |
| Terminology | 19 | Layout Guidelines | 29 |
| Theory of Operation | 21 | Galvanically Isolated Interface | 29 |
| DAC Architecture | 21 | Microprocessor Interfacing | 29 |
| Reference Buffers | 21 | Outline Dimensions | 30 |
| Serial Interface | 21 | Ordering Guide | 30 |
| Simultaneous Updating via $\overline{\text{LDAC}}$ | 23 | | |
| Transfer Function | 23 | | |
| Asynchronous Clear ($\overline{\text{CLR}}$) | 23 | | |

REVISION HISTORY

9/11—Rev. D to Rev. E

| | |
|--|---|
| Changed 50 MHz to 30 MHz Throughout | 1 |
| Changes to t_1 , t_2 , and t_3 Parameters, Table 3 | 7 |

7/11—Rev. C to Rev. D

| | |
|--|---|
| Changed 30 MHz to 50 MHz Throughout | 1 |
| Changes to t_1 , t_2 , and t_3 Parameters, Table 3 | 7 |

8/09—Rev. B to Rev. C

| | |
|---|---|
| Deleted Endnote 1 in Table 1 | 4 |
| Deleted Endnote 1 in Table 2 | 6 |
| Deleted Endnote 1 and Changes to t_6 Parameter in Table 3 | 7 |

2/09—Rev. A to Rev. B

| | |
|--|----|
| Changes to Figure 1 | 3 |
| Changes to Table 1 Conditions and Added Endnote to Table 1 | 4 |
| Added Endnote to Table 2 | 6 |
| Added Endnote to Table 3 | 7 |
| Changes to Table 5 | 10 |

1/09—Rev. 0 to Rev. A

| | |
|---------------------------|---|
| Changes to Figure 1 | 3 |
|---------------------------|---|

10/08—Revision 0: Initial Version

FUNCTIONAL BLOCK DIAGRAM

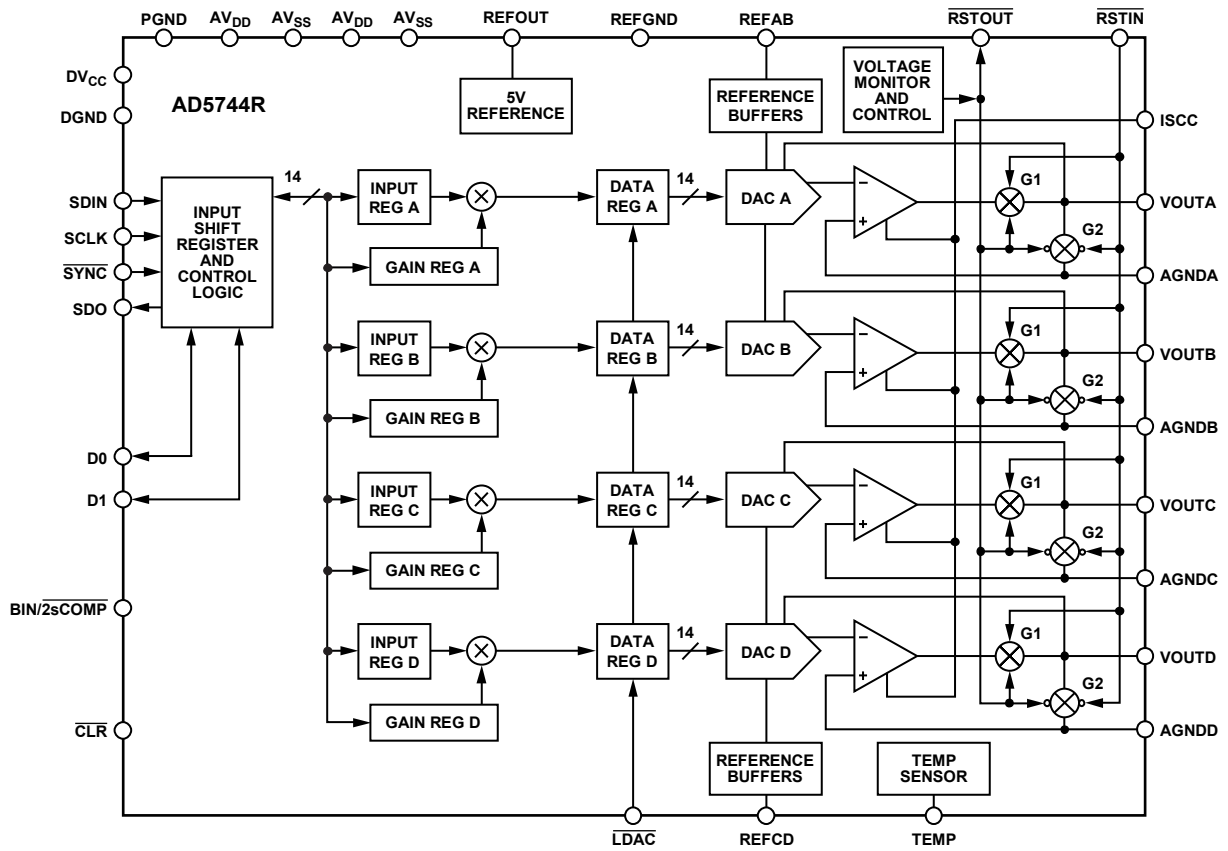

Figure 1.

061065-001

SPECIFICATIONS

$AV_{DD} = 11.4\text{ V to }16.5\text{ V}$, $AV_{SS} = -11.4\text{ V to }-16.5\text{ V}$, $AGND = DGND = REFGND = PGND = 0\text{ V}$; $REFAB = REFCD = 5\text{ V external}$; $DV_{CC} = 2.7\text{ V to }5.25\text{ V}$, $R_{LOAD} = 10\text{ k}\Omega$, $C_L = 200\text{ pF}$. All specifications T_{MIN} to T_{MAX} , unless otherwise noted.

Table 1.

| Parameter | Min | Typ | Max | Unit | Test Conditions/Comments ¹ |
|--|----------|------|----------|-----------------|--|
| ACCURACY | | | | | |
| Resolution | 14 | | | Bits | Outputs unloaded |
| Relative Accuracy (INL) | -1 | | +1 | LSB | |
| Differential Nonlinearity (DNL) | -1 | | +1 | LSB | Guaranteed monotonic |
| Bipolar Zero Error | -2 | | +2 | mV | 25°C; error at other temperatures obtained using bipolar zero tempco |
| | | | | mV | |
| Bipolar Zero Tempco ² | -2 | | +2 | ppm FSR/°C | |
| Zero-Scale Error | -2 | | +2 | mV | 25°C; error at other temperatures obtained using zero-scale tempco |
| | | | | mV | |
| Zero-Scale Tempco ² | -2 | | +2 | ppm FSR/°C | |
| Gain Error | -0.02 | | +0.02 | % FSR | |
| Gain Tempco ² | -2 | | +2 | ppm FSR/°C | |
| DC Crosstalk ² | | | 0.125 | LSB | |
| REFERENCE INPUT/OUTPUT | | | | | |
| Reference Input ² | | | | | |
| Reference Input Voltage | | 5 | | V | ±1% for specified performance |
| DC Input Impedance | 1 | | | MΩ | Typically 100 MΩ |
| Input Current | -10 | | +10 | μA | Typically ±30 nA |
| Reference Range | 1 | | 7 | V | |
| Reference Output | | | | | |
| Output Voltage | 4.995 | 5 | 5.005 | V | 25°C, $AV_{DD}/AV_{SS} = \pm 13.5\text{ V}$ |
| Reference Tempco ² | -10 | ±1.7 | +10 | ppm/°C | |
| R_{LOAD} ² | 1 | | | MΩ | |
| Power Supply Sensitivity ¹ | | 300 | | μV/V | |
| Output Noise ² | | 18 | | μV p-p | 0.1 Hz to 10 Hz |
| Noise Spectral Density ² | | 75 | | nV/√Hz | 10 kHz |
| Output Voltage Drift vs. Time ² | | ±40 | | ppm/500 hr | |
| | | ±50 | | ppm/1000 hr | |
| Thermal Hysteresis ¹ | | 70 | | ppm | First temperature cycle |
| | | 30 | | ppm | Subsequent temperature cycles |
| OUTPUT CHARACTERISTICS² | | | | | |
| Output Voltage Range ³ | -10.5263 | | +10.5263 | V | $AV_{DD}/AV_{SS} = \pm 11.4\text{ V}$, $V_{REFIN} = 5\text{ V}$ |
| | -14.7368 | | +14.7368 | V | $AV_{DD}/AV_{SS} = \pm 16.5\text{ V}$, $V_{REFIN} = 7\text{ V}$ |
| Output Voltage Drift vs. Time | | ±13 | | ppm FSR/500 hr | |
| | | ±15 | | ppm FSR/1000 hr | |
| Short-Circuit Current | | 10 | | mA | $R_{ISCC} = 6\text{ k}\Omega$, see Figure 31 |
| Load Current | -1 | | +1 | mA | For specified performance |
| Capacitive Load Stability | | | | | |
| $R_{LOAD} = \infty$ | | | 200 | pF | |
| $R_{LOAD} = 10\text{ k}\Omega$ | | | 1000 | pF | |
| DC Output Impedance | | | 0.3 | Ω | |

| Parameter | Min | Typ | Max | Unit | Test Conditions/Comments ¹ |
|--|-----------------|------|-------|---------------|---|
| DIGITAL INPUTS² | | | | | |
| Input High Voltage, V_{IH} | 2.4 | | | V | $DV_{CC} = 2.7\text{ V to }5.25\text{ V}$ |
| Input Low Voltage, V_{IL} | | | 0.8 | V | |
| Input Current | -1.2 | | +1.2 | μA | Per pin |
| Pin Capacitance | | | 10 | pF | Per pin |
| DIGITAL OUTPUTS (D0, D1, SDO)² | | | | | |
| Output Low Voltage | | | 0.4 | V | $DV_{CC} = 5\text{ V} \pm 5\%$, sinking 200 μA |
| Output High Voltage | $DV_{CC} - 1$ | | | V | $DV_{CC} = 5\text{ V} \pm 5\%$, sourcing 200 μA |
| Output Low Voltage | | | 0.4 | V | $DV_{CC} = 2.7\text{ V to }3.6\text{ V}$, sinking 200 μA |
| Output High Voltage | $DV_{CC} - 0.5$ | | | V | $DV_{CC} = 2.7\text{ V to }3.6\text{ V}$, sourcing 200 μA |
| High Impedance Leakage Current | -1 | | +1 | μA | SDO only |
| High Impedance Output Capacitance | | 5 | | pF | SDO only |
| DIE TEMPERATURE SENSOR² | | | | | |
| Output Voltage at 25°C | | 1.47 | | V | Die temperature |
| Output Voltage Scale Factor | | 5 | | mV/°C | |
| Output Voltage Range | 1.175 | | 1.9 | V | -40°C to +105°C |
| Output Load Current | | | 200 | μA | Current source only |
| Power-On Time | | 80 | | ms | |
| POWER REQUIREMENTS | | | | | |
| AV_{DD} | +11.4 | | +16.5 | V | |
| AV_{SS} | -11.4 | | -16.5 | V | |
| DV_{CC} | 2.7 | | 5.25 | V | |
| Power Supply Sensitivity ² | | | | | |
| $\Delta V_{OUT}/\Delta AV_{DD}$ | | -85 | | dB | |
| AI_{DD} | | | 3.55 | mA/channel | Outputs unloaded |
| AI_{SS} | | | 2.8 | mA/channel | Outputs unloaded |
| DI_{CC} | | | 1.2 | mA | $V_{IH} = DV_{CC}$, $V_{IL} = DGND$, 750 μA typ |
| Power Dissipation | | 275 | | mW | $\pm 12\text{ V}$ operation output unloaded |

¹ Temperature range: -40°C to +85°C; typical at +25°C. Device functionality is guaranteed to 105°C with degraded performance.

² Guaranteed by design and characterization; not production tested.

³ Output amplifier headroom requirement is 1.4 V minimum.

AC PERFORMANCE CHARACTERISTICS

$AV_{DD} = 11.4\text{ V to }16.5\text{ V}$, $AV_{SS} = -11.4\text{ V to }-16.5\text{ V}$, $AGND = DGND = REFGND = PGND = 0\text{ V}$; $REFAB = REFCD = 5\text{ V external}$; $DV_{CC} = 2.7\text{ V to }5.25\text{ V}$, $R_{LOAD} = 10\text{ k}\Omega$, $C_L = 200\text{ pF}$. All specifications T_{MIN} to T_{MAX} , unless otherwise noted.

Table 2.

| Parameter | Min | Typ | Max | Unit | Test Conditions/Comments |
|--|-----|-------|-----|------------------------------|---|
| DYNAMIC PERFORMANCE¹ | | | | | |
| Output Voltage Settling Time | | 8 | 10 | μs | Full-scale step to ± 1 LSB |
| | | | | μs | |
| | | 2 | | μs | 512 LSB step settling |
| Slew Rate | | 5 | | $\text{V}/\mu\text{s}$ | |
| Digital-to-Analog Glitch Energy | | 8 | | $\text{nV}\cdot\text{sec}$ | |
| Glitch Impulse Peak Amplitude | | | 25 | mV | |
| Channel-to-Channel Isolation | | 80 | | dB | |
| DAC-to-DAC Crosstalk | | 8 | | $\text{nV}\cdot\text{sec}$ | |
| Digital Crosstalk | | 2 | | $\text{nV}\cdot\text{sec}$ | |
| Digital Feedthrough | | 2 | | $\text{nV}\cdot\text{sec}$ | Effect of input bus activity on DAC outputs |
| Output Noise (0.1 Hz to 10 Hz) | | 0.025 | | LSB p-p | |
| Output Noise (0.1 Hz to 100 kHz) | | | 45 | $\mu\text{V rms}$ | |
| 1/f Corner Frequency | | 1 | | kHz | |
| Output Noise Spectral Density | | 60 | | $\text{nV}/\sqrt{\text{Hz}}$ | Measured at 10 kHz |
| Complete System Output Noise Spectral Density ² | | 80 | | $\text{nV}/\sqrt{\text{Hz}}$ | Measured at 10 kHz |

¹ Guaranteed by design and characterization; not production tested.

² Includes noise contributions from integrated reference buffers, 14-bit DAC, and output amplifier.

TIMING CHARACTERISTICS

$AV_{DD} = 11.4\text{ V to }16.5\text{ V}$, $AV_{SS} = -11.4\text{ V to }-16.5\text{ V}$, $AGND = DGND = REFGND = PGND = 0\text{ V}$; $REFAB = REFCD = 5\text{ V external}$; $DV_{CC} = 2.7\text{ V to }5.25\text{ V}$, $R_{LOAD} = 10\text{ k}\Omega$, $C_L = 200\text{ pF}$. All specifications T_{MIN} to T_{MAX} , unless otherwise noted.

Table 3.

| Parameter ^{1, 2, 3} | Limit at T_{MIN}, T_{MAX} | Unit | Description |
|------------------------------|-----------------------------|-------------------|--|
| t_1 | 33 | ns min | SCLK cycle time |
| t_2 | 13 | ns min | SCLK high time |
| t_3 | 13 | ns min | SCLK low time |
| t_4 | 13 | ns min | \overline{SYNC} falling edge to SCLK falling edge setup time |
| t_5^4 | 13 | ns min | 24 th SCLK falling edge to \overline{SYNC} rising edge |
| t_6 | 90 | ns min | Minimum \overline{SYNC} high time |
| t_7 | 2 | ns min | Data setup time |
| t_8 | 5 | ns min | Data hold time |
| t_9 | 1.7 | $\mu\text{s min}$ | \overline{SYNC} rising edge to \overline{LDAC} falling edge (all DACs updated) |
| | 480 | ns min | \overline{SYNC} rising edge to \overline{LDAC} falling edge (single DAC updated) |
| t_{10} | 10 | ns min | \overline{LDAC} pulse width low |
| t_{11} | 500 | ns max | \overline{LDAC} falling edge to DAC output response time |
| t_{12} | 10 | $\mu\text{s max}$ | DAC output settling time |
| t_{13} | 10 | ns min | \overline{CLR} pulse width low |
| t_{14} | 2 | $\mu\text{s max}$ | \overline{CLR} pulse activation time |
| $t_{15}^{5, 6}$ | 25 | ns max | SCLK rising edge to SDO valid |
| t_{16} | 13 | ns min | \overline{SYNC} rising edge to SCLK falling edge |
| t_{17} | 2 | $\mu\text{s max}$ | \overline{SYNC} rising edge to DAC output response time ($LDAC = 0$) |
| t_{18} | 170 | ns min | \overline{LDAC} falling edge to \overline{SYNC} rising edge |

¹ Guaranteed by design and characterization; not production tested.

² All input signals are specified with $t_r = t_f = 5\text{ ns}$ (10% to 90% of DV_{CC}) and timed from a voltage level of 1.2 V.

³ See Figure 2, Figure 3, and Figure 4.

⁴ Standalone mode only.

⁵ Measured with the load circuit of Figure 5.

⁶ Daisy-chain mode only.

Timing Diagrams

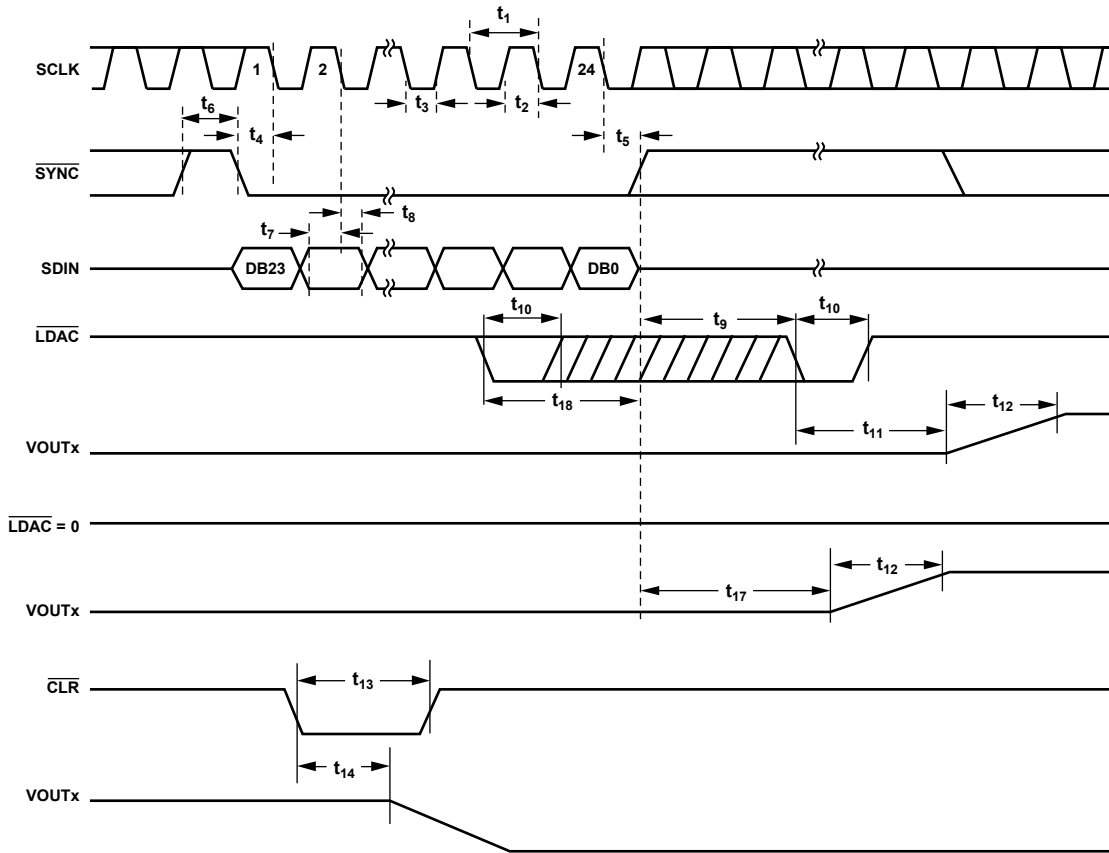

Figure 2. Serial Interface Timing Diagram

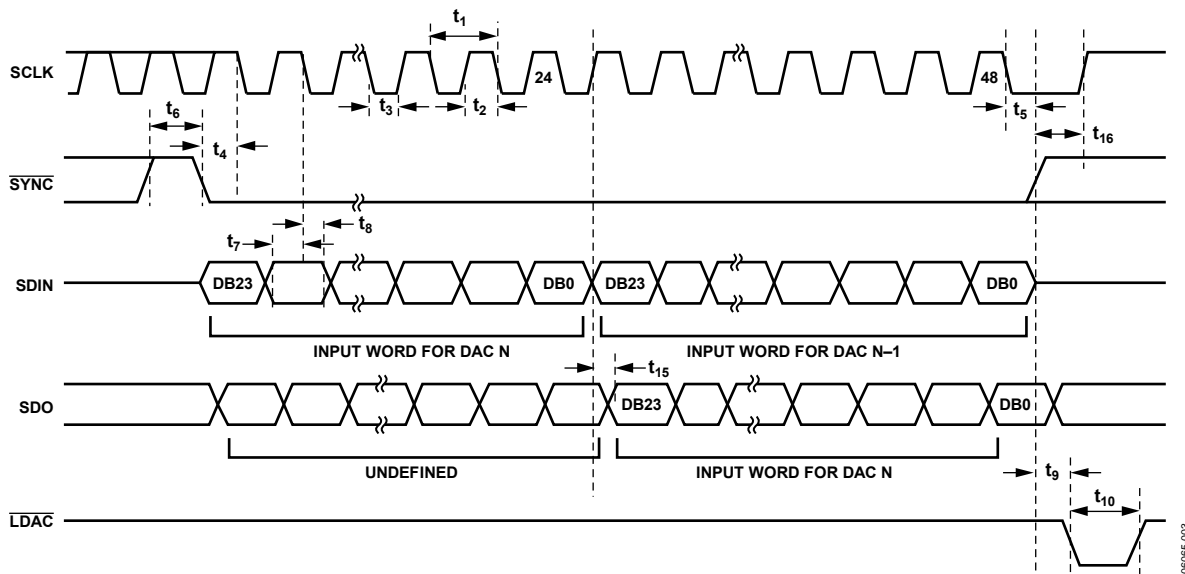
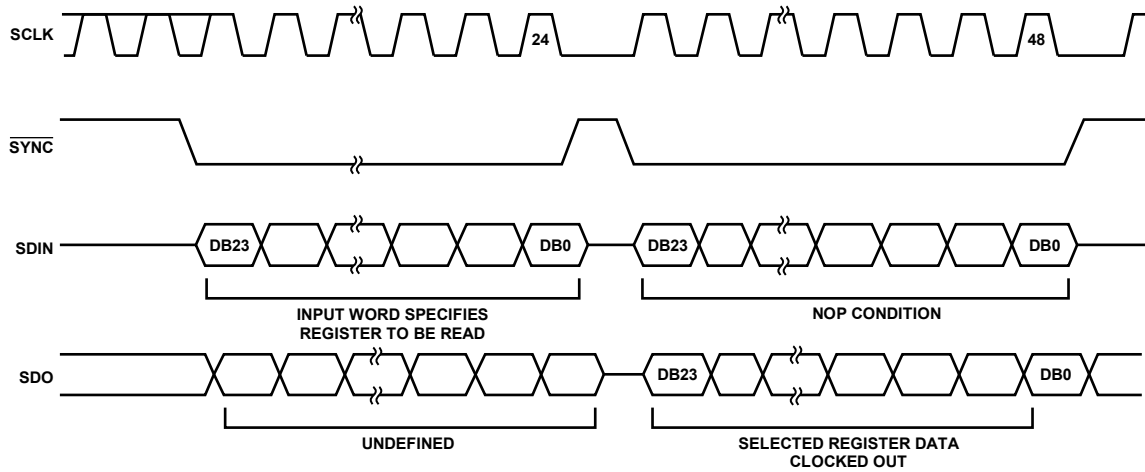
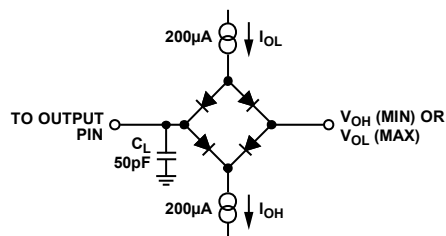

Figure 3. Daisy-Chain Timing Diagram



06065-004

Figure 4. Readback Timing Diagram



06065-005

Figure 5. Load Circuit for SDO Timing Diagram

ABSOLUTE MAXIMUM RATINGS

$T_A = 25^\circ\text{C}$, unless otherwise noted. Transient currents of up to 100 mA do not cause SCR latch-up.

Table 4.

| Parameter | Rating |
|---|---|
| AV_{DD} to AGND, DGND | -0.3 V to +17 V |
| AV_{SS} to AGND, DGND | +0.3 V to -17 V |
| DV_{CC} to DGND | -0.3 V to +7 V |
| Digital Inputs to DGND | -0.3 V to ($DV_{CC} + 0.3$ V) or +7 V, whichever is less |
| Digital Outputs to DGND | -0.3 V to $DV_{CC} + 0.3$ V |
| REFAB, REFCD to AGNDx, PGND | -0.3 V to $AV_{DD} + 0.3$ V |
| REFOUT to AGNDx | AV_{SS} to AV_{DD} |
| TEMP | AV_{SS} to AV_{DD} |
| VOUtx to AGNDx | AV_{SS} to AV_{DD} |
| AGND to DGND | -0.3 V to +0.3 V |
| Operating Temperature Range Industrial | -40°C to +85°C |
| Storage Temperature Range | -65°C to +150°C |
| Junction Temperature (T_J max) | 150°C |
| Lead Temperature (Soldering) | JEDEC Industry Standard J-STD-020 |

Stresses above those listed under Absolute Maximum Ratings may cause permanent damage to the device. This is a stress rating only; functional operation of the device at these or any other conditions above those indicated in the operational section of this specification is not implied. Exposure to absolute maximum rating conditions for extended periods may affect device reliability.

THERMAL RESISTANCE

θ_{JA} is specified for the worst-case conditions, that is, a device soldered in a circuit board for surface-mount packages.

Table 5. Thermal Resistance

| Package Type | θ_{JA} | θ_{JC} | Unit |
|--------------|---------------|---------------|---------------------------|
| 32-Lead TQFP | 65 | 12 | $^\circ\text{C}/\text{W}$ |

ESD CAUTION



ESD (electrostatic discharge) sensitive device. Charged devices and circuit boards can discharge without detection. Although this product features patented or proprietary protection circuitry, damage may occur on devices subjected to high energy ESD. Therefore, proper ESD precautions should be taken to avoid performance degradation or loss of functionality.

PIN CONFIGURATION AND FUNCTION DESCRIPTIONS

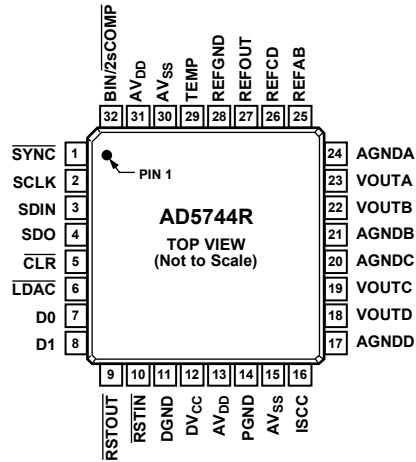

Figure 6. Pin Configuration

Table 6. Pin Function Descriptions

| Pin No. | Mnemonic | Description |
|---------|------------------|--|
| 1 | SYNC | Active Low Input. This is the frame synchronization signal for the serial interface. While SYNC is low, data is transferred in on the falling edge of SCLK. |
| 2 | SCLK | Serial Clock Input. Data is clocked into the shift register on the falling edge of SCLK. This operates at clock speeds of up to 30 MHz. |
| 3 | SDIN | Serial Data Input. Data must be valid on the falling edge of SCLK. |
| 4 | SDO | Serial Data Output. This pin is used to clock data from the serial register in daisy-chain or readback mode. |
| 5 | CLR | Negative Edge Triggered Input. ¹ Asserting this pin sets the data register to 0x0000. |
| 6 | LDAC | Load DAC. This logic input is used to update the data register and, consequently, the analog outputs. When tied permanently low, the addressed data register is updated on the rising edge of SYNC. If LDAC is held high during the write cycle, the DAC input register is updated, but the output update is held off until the falling edge of LDAC. In this mode, all analog outputs can be updated simultaneously on the falling edge of LDAC. The LDAC pin must not be left unconnected. |
| 7, 8 | D0, D1 | Digital I/O Port. D0 and D1 form a digital I/O port. The user can set up these pins as inputs or outputs that are configurable and readable over the serial interface. When configured as inputs, these pins have weak internal pull-ups to DV _{CC} . When programmed as outputs, D0 and D1 are referenced by DV _{CC} and DGND. |
| 9 | RSTOUT | Reset Logic Output. This is the output from the on-chip voltage monitor used in the reset circuit. If desired, it can be used to control other system components. |
| 10 | RSTIN | Reset Logic Input. This input allows external access to the internal reset logic. Applying a Logic 0 to this input clamps the DAC outputs to 0V. In normal operation, RSTIN should be tied to Logic 1. Register values remain unchanged. |
| 11 | DGND | Digital Ground Pin. |
| 12 | DV _{CC} | Digital Supply Pin. Voltage ranges from 2.7 V to 5.25 V. |
| 13, 31 | AV _{DD} | Positive Analog Supply Pins. Voltage ranges from 11.4 V to 16.5 V. |
| 14 | PGND | Ground Reference Point for Analog Circuitry. |
| 15, 30 | AV _{SS} | Negative Analog Supply Pins. Voltage ranges from -11.4 V to -16.5 V. |
| 16 | ISCC | This pin is used in association with an optional external resistor to AGND to program the short-circuit current of the output amplifiers. Refer to the Design Features section for more information. |
| 17 | AGNDD | Ground Reference Pin for DAC D Output Amplifier. |
| 18 | VOUTD | Analog Output Voltage of DAC D. Buffered output with a nominal full-scale output range of ±10V. The output amplifier is capable of directly driving a 10 kΩ, 200 pF load. |
| 19 | VOUTC | Analog Output Voltage of DAC C. Buffered output with a nominal full-scale output range of ±10V. The output amplifier is capable of directly driving a 10 kΩ, 200 pF load. |
| 20 | AGNDC | Ground Reference Pin for DAC C Output Amplifier. |
| 21 | AGNDB | Ground Reference Pin for DAC B Output Amplifier. |
| 22 | VOUTB | Analog Output Voltage of DAC B. Buffered output with a nominal full-scale output range of ±10V. The output amplifier is capable of directly driving a 10 kΩ, 200 pF load. |

| Pin No. | Mnemonic | Description |
|---------|--------------------------------|---|
| 23 | VOUTA | Analog Output Voltage of DAC A. Buffered output with a nominal full-scale output range of ± 10 V. The output amplifier is capable of directly driving a 10 k Ω , 200 pF load. |
| 24 | AGNDA | Ground Reference Pin for DAC A Output Amplifier. |
| 25 | REFAB | External Reference Voltage Input for Channel A and Channel B. The reference input range is 1 V to 7 V, and it programs the full-scale output voltage. $V_{REFIN} = 5$ V for specified performance. |
| 26 | REFCD | External Reference Voltage Input for Channel C and Channel D. The reference input range is 1 V to 7 V, and it programs the full-scale output voltage. $V_{REFIN} = 5$ V for specified performance. |
| 27 | REFOUT | Reference Output. This is the reference output from the internal voltage reference. The internal reference is 5 V \pm 3 mV at 25°C, with a reference temperature coefficient of 10 ppm/°C. |
| 28 | REFGND | Reference Ground Return for the Reference Generator and Buffers. |
| 29 | TEMP | This pin provides an output voltage proportional to temperature. The output voltage is 1.47 V typical at 25°C die temperature; variation with temperature is 5 mV/°C. |
| 32 | $\overline{\text{BIN/2sCOMP}}$ | This pin determines the DAC coding. This pin should be hardwired to either DV _{CC} or DGND. When hardwired to DV _{CC} , input coding is offset binary (see Table 7). When hardwired to DGND, input coding is twos complement (see Table 8). |

¹ Internal pull-up device on this logic input. Therefore, it can be left floating; and it defaults to a logic high condition.

TYPICAL PERFORMANCE CHARACTERISTICS

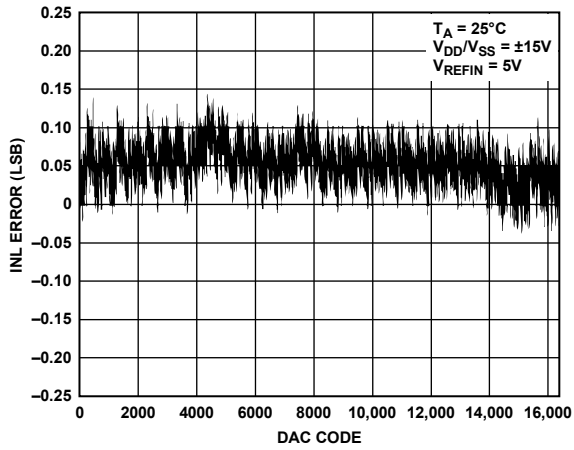

Figure 7. Integral Nonlinearity Error vs. DAC Code, $V_{DD}/V_{SS} = \pm 15 V$

06095-009

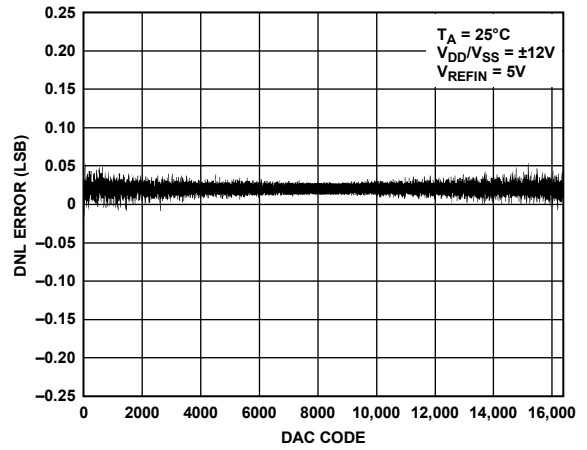

Figure 10. Differential Nonlinearity Error vs. DAC Code, $V_{DD}/V_{SS} = \pm 12 V$

06095-014

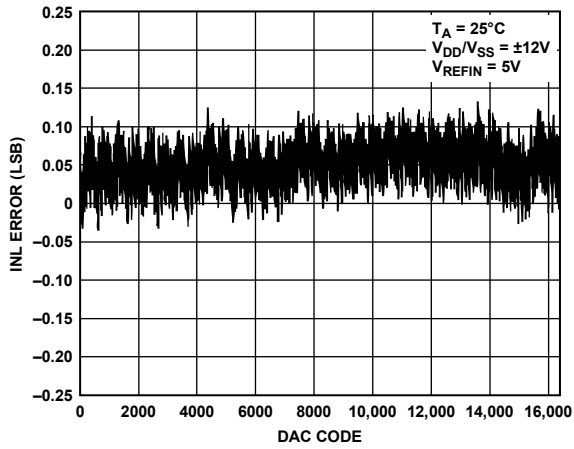

Figure 8. Integral Nonlinearity Error vs. DAC Code, $V_{DD}/V_{SS} = \pm 12 V$

06095-010

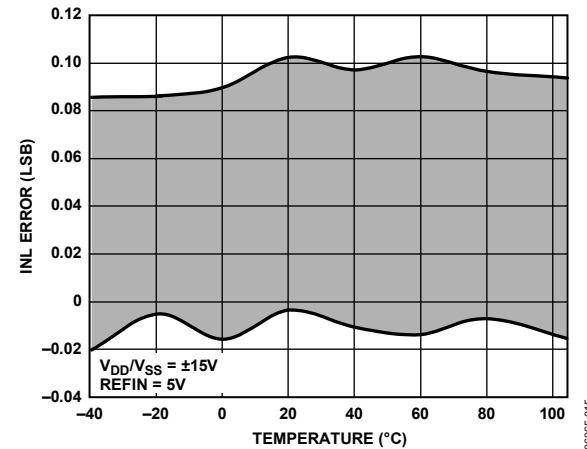

Figure 11. Integral Nonlinearity Error vs. Temperature, $V_{DD}/V_{SS} = \pm 15 V$

06095-015

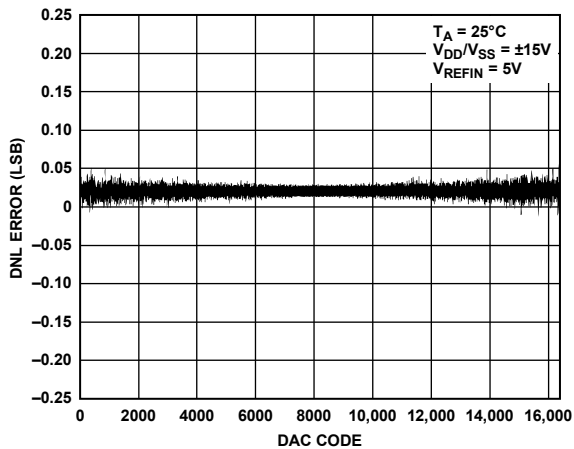

Figure 9. Differential Nonlinearity Error vs. DAC Code, $V_{DD}/V_{SS} = \pm 15 V$

06095-013

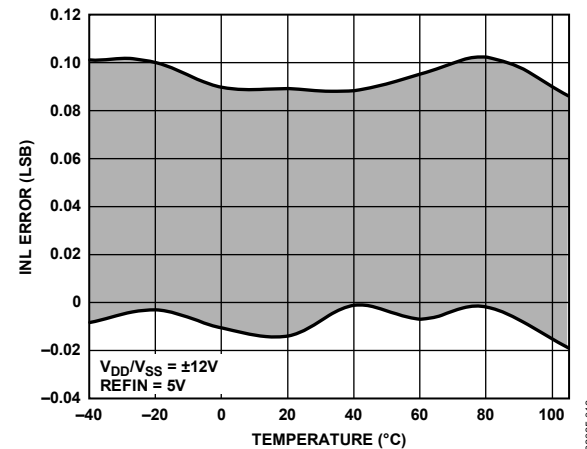

Figure 12. Integral Nonlinearity Error vs. Temperature, $V_{DD}/V_{SS} = \pm 12 V$

06095-016

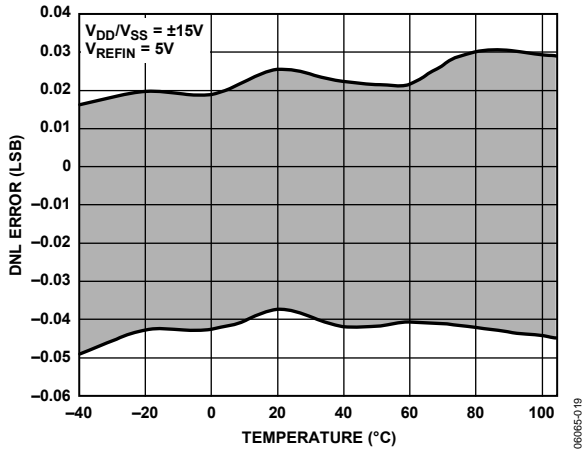

Figure 13. Differential Nonlinearity Error vs. Temperature, $V_{DD}/V_{SS} = \pm 15\text{ V}$

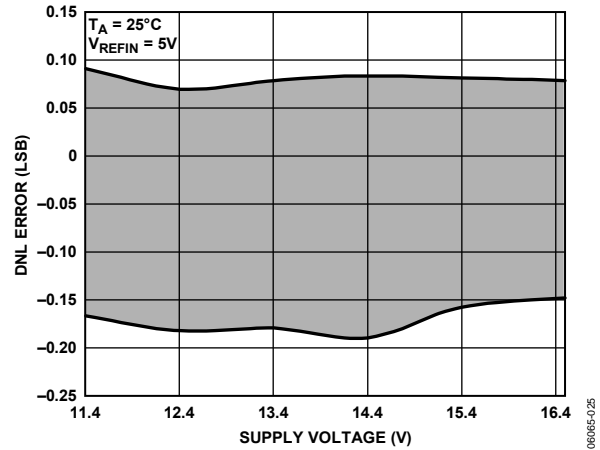

Figure 16. Differential Nonlinearity Error vs. Supply Voltage

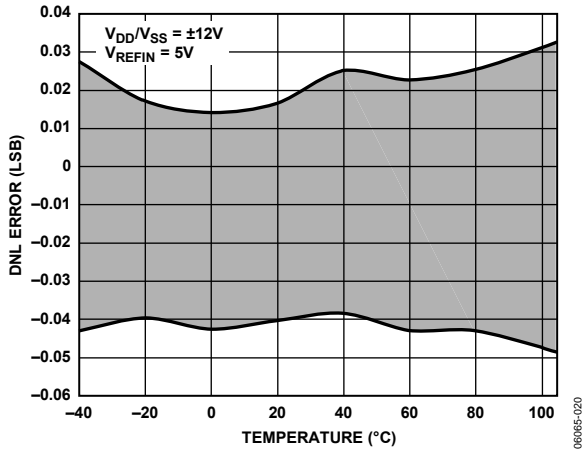

Figure 14. Differential Nonlinearity Error vs. Temperature, $V_{DD}/V_{SS} = \pm 12\text{ V}$

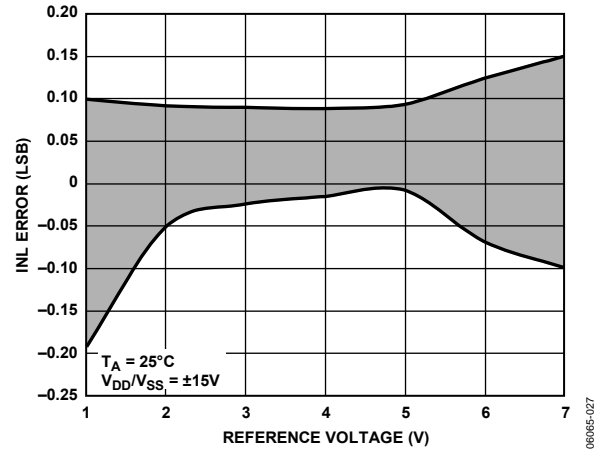

Figure 17. Integral Nonlinearity Error vs. Reference Voltage $V_{DD}/V_{SS} = \pm 15\text{ V}$

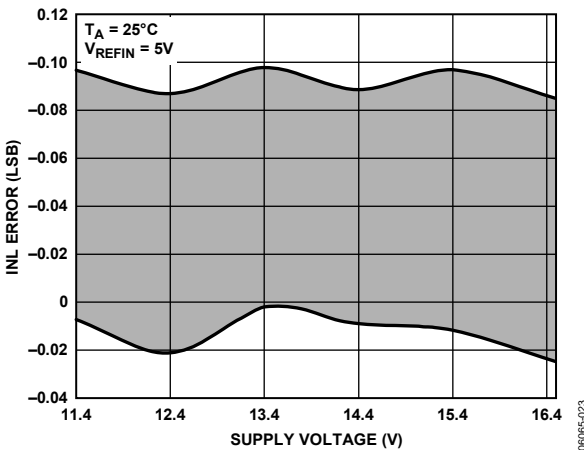

Figure 15. Integral Nonlinearity Error vs. Supply Voltage

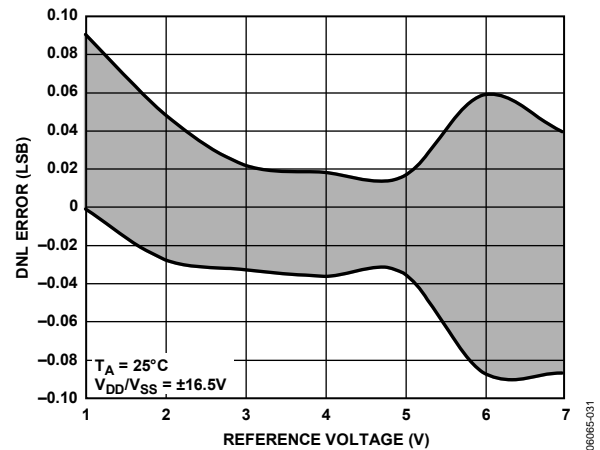

Figure 18. Differential Nonlinearity Error vs. Reference Voltage $V_{DD}/V_{SS} = \pm 16.5\text{ V}$

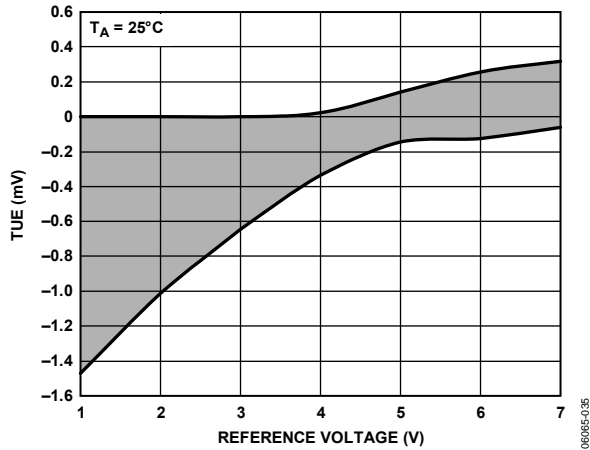

Figure 19. Total Unadjusted Error vs. Reference Voltage, $V_{DD}/V_{SS} = \pm 16.5V$

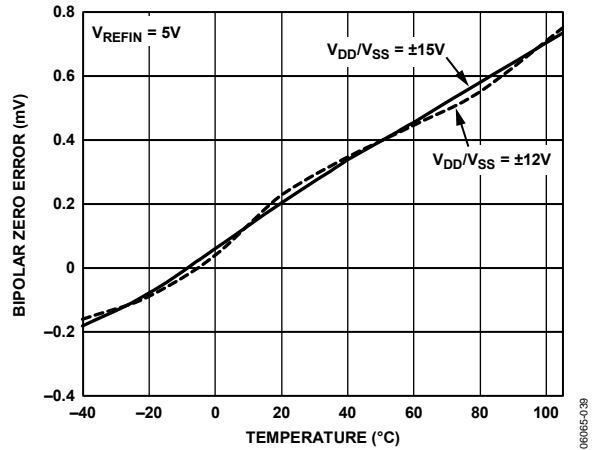

Figure 22. Bipolar Zero Error vs. Temperature

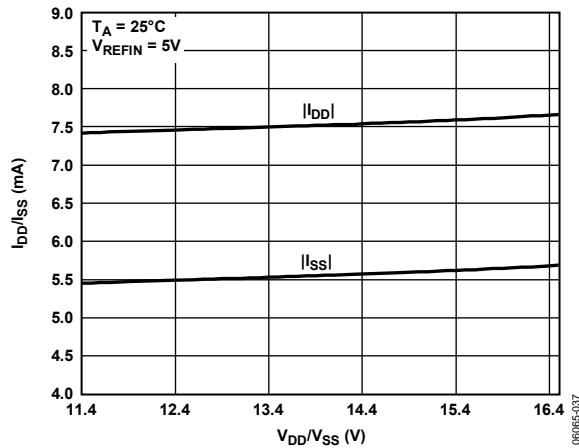

Figure 20. I_{DD}/I_{SS} vs. V_{DD}/V_{SS}

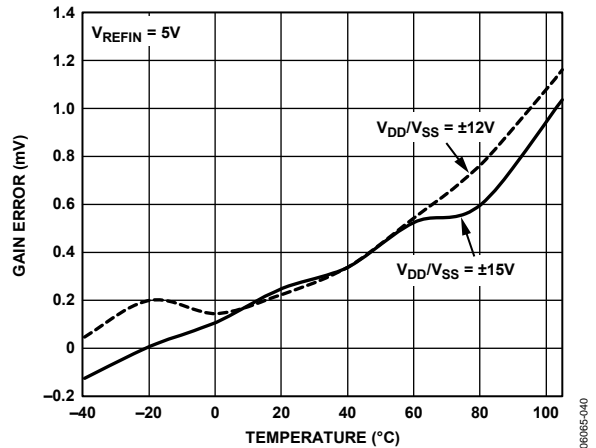

Figure 23. Gain Error vs. Temperature

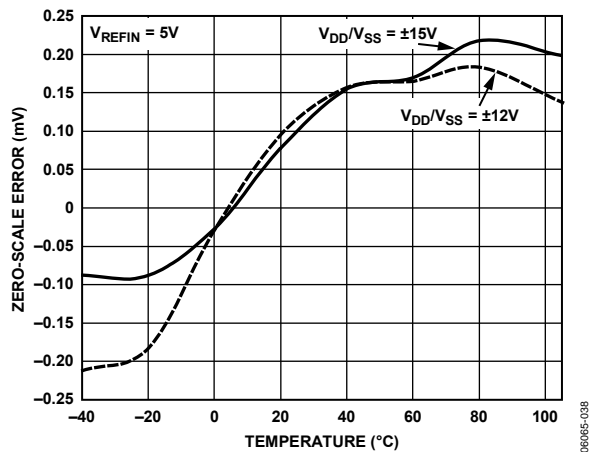

Figure 21. Zero-Scale Error vs. Temperature

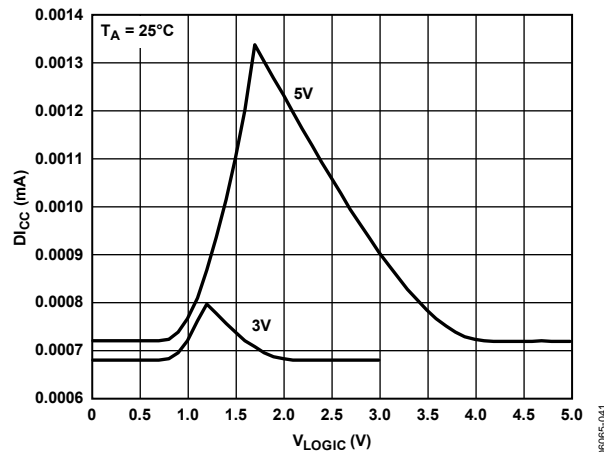

Figure 24. D_{ICC} vs. Logic Input Voltage

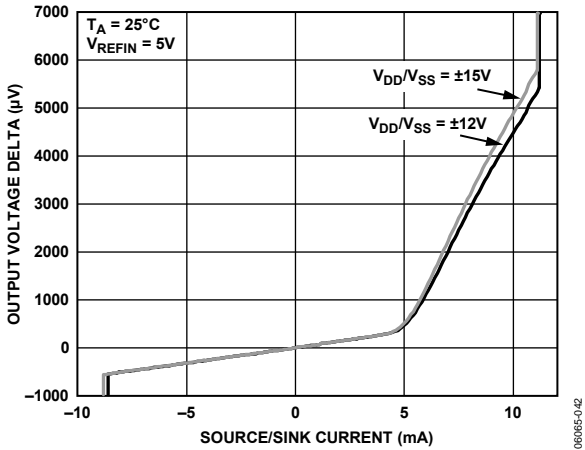

Figure 25. Source and Sink Capability of Output Amplifier with Positive Full Scale Loaded

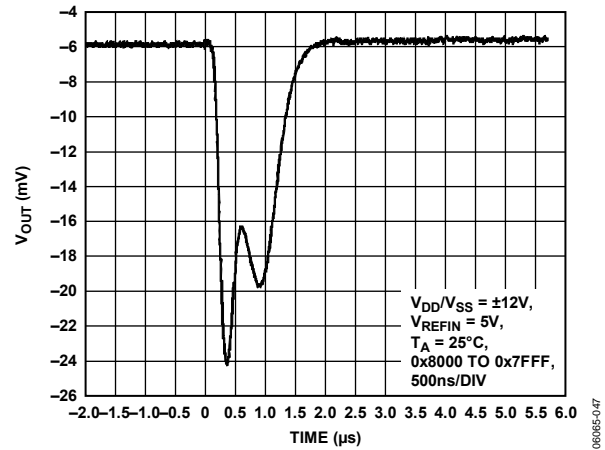

Figure 28. Major Code Transition Glitch Energy, $V_{DD}/V_{SS} = \pm 12V$

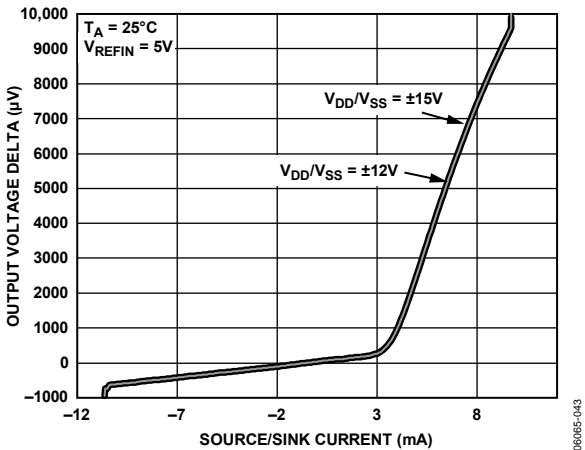

Figure 26. Source and Sink Capability of Output Amplifier with Negative Full Scale Loaded

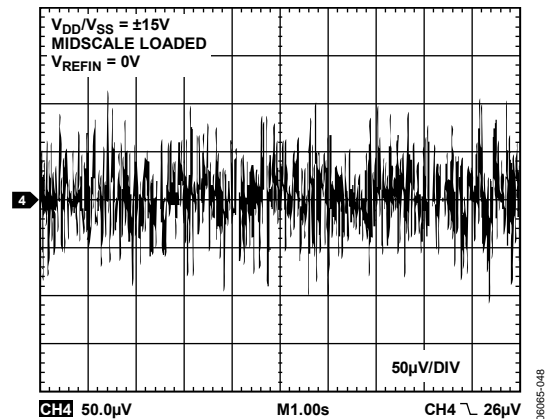

Figure 29. Peak-to-Peak Noise (100 kHz Bandwidth)

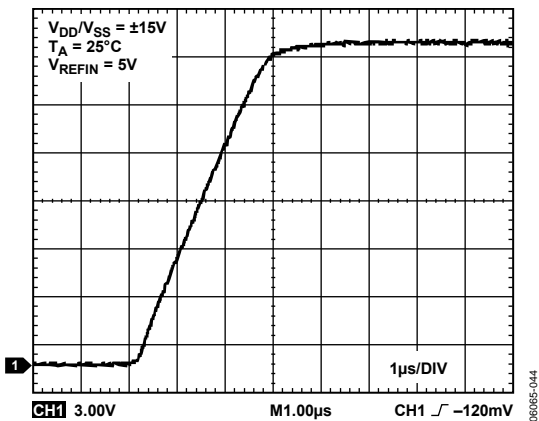

Figure 27. Full-Scale Settling Time

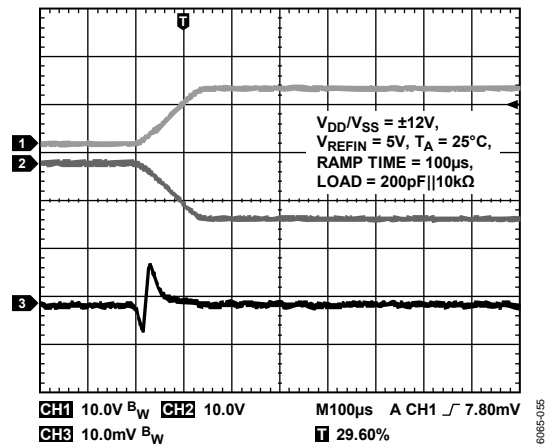

Figure 30. V_{OUTx} vs. V_{DD}/V_{SS} on Power-Up

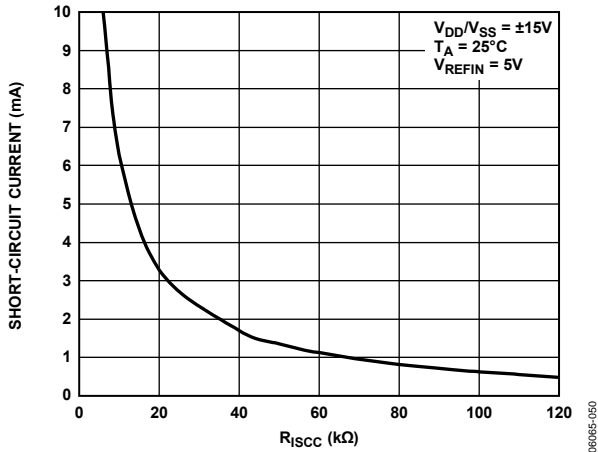

Figure 31. Short-Circuit Current vs. R_{isc}

06065-050

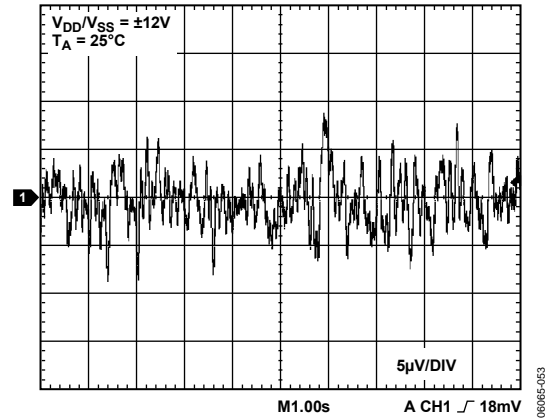

Figure 34. REFOUT Output Noise 0.1 Hz to 10 Hz

06065-053

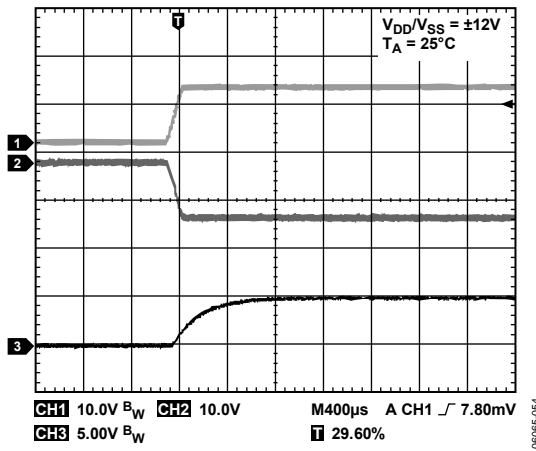

Figure 32. REFOUT Turn-On Transient

06065-054

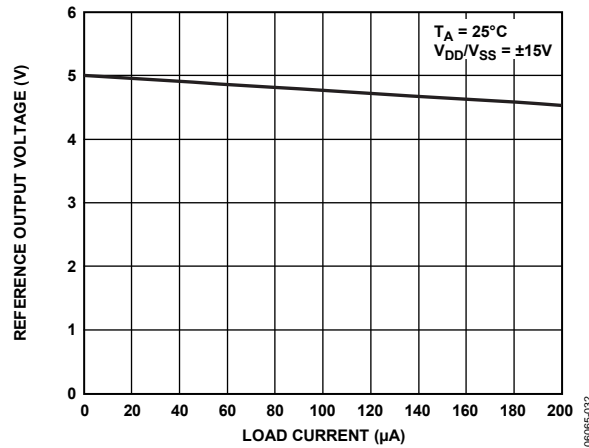

Figure 35. REFOUT Load Regulation

06065-032

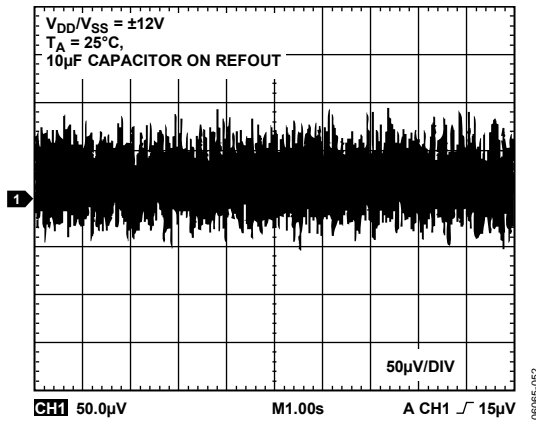

Figure 33. REFOUT Output Noise 100 kHz Bandwidth

06065-052

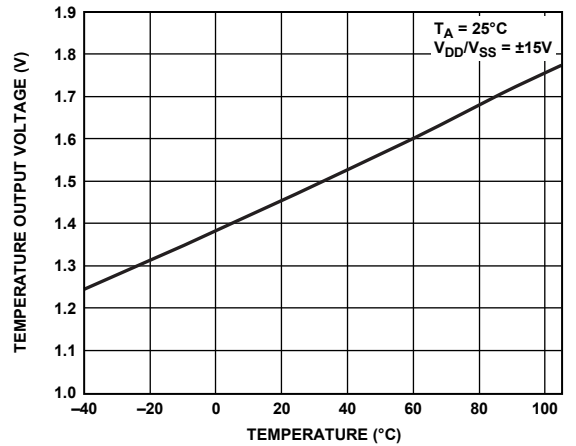

Figure 36. Temperature Output Voltage vs. Temperature

06065-033

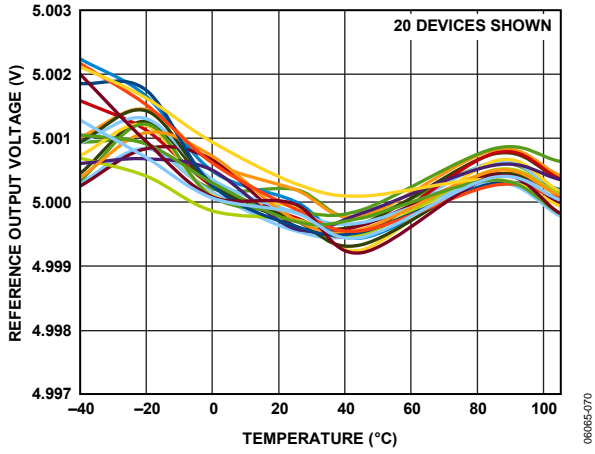

Figure 37. Reference Output Voltage vs. Temperature

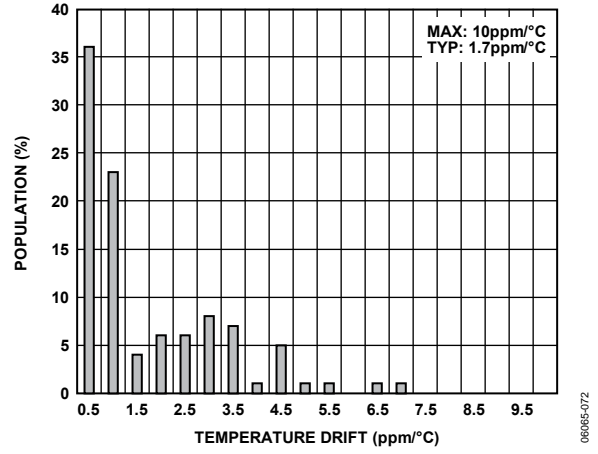

Figure 38. Reference Output Temperature Drift (-40°C to +85°C)

TERMINOLOGY

Relative Accuracy or Integral Nonlinearity (INL)

For the DAC, a measure of the maximum deviation, in LSBs, from a straight line passing through the endpoints of the DAC transfer function.

Differential Nonlinearity (DNL)

The difference between the measured change and the ideal 1 LSB change between any two adjacent codes. A specified differential nonlinearity of ± 1 LSB maximum ensures monotonicity. This DAC is guaranteed monotonic.

Monotonicity

A DAC is monotonic if the output either increases or remains constant for increasing digital input code. The AD5744R is monotonic over its full operating temperature range.

Bipolar Zero Error

The deviation of the analog output from the ideal half-scale output of 0 V when the data register is loaded with 0x8000 (offset binary coding) or 0x0000 (twos complement coding). Figure 22 shows a plot of bipolar zero error vs. temperature.

Bipolar Zero Temperature Coefficient

The measure of the change in the bipolar zero error with a change in temperature. It is expressed as parts per million of full-scale range per degree Celsius (ppm FSR/ $^{\circ}$ C).

Full-Scale Error

The measure of the output error when full-scale code is loaded to the data register. Ideally, the output voltage should be $2 \times V_{\text{REFIN}} - 1$ LSB. Full-scale error is expressed as a percentage of full-scale range (% FSR).

Negative Full-Scale Error/Zero-Scale Error

The error in the DAC output voltage when 0x0000 (offset binary coding) or 0x8000 (twos complement coding) is loaded to the data register. Ideally, the output voltage should be $-2 \times V_{\text{REFIN}}$. Figure 21 shows a plot of zero-scale error vs. temperature.

Output Voltage Settling Time

The amount of time it takes for the output to settle to a specified level for a full-scale input change.

Slew Rate

A limitation in the rate of change of the output voltage. The output slewing speed of a voltage output DAC is usually limited by the slew rate of the amplifier used at its output. Slew rate is measured from 10% to 90% of the output signal and is given in volts per microsecond (V/ μ s).

Gain Error

A measure of the span error of the DAC. It is the deviation in slope of the DAC transfer characteristic from the ideal, expressed as a percentage of the full-scale range (% FSR). Figure 23 shows a plot of gain error vs. temperature.

Total Unadjusted Error (TUE)

A measure of the output error, considering all the various errors. Figure 19 shows a plot of total unadjusted error vs. reference voltage.

Zero-Scale Error Temperature Coefficient

A measure of the change in zero-scale error with a change in temperature. It is expressed as parts per million of full-scale range per degree Celsius (ppm FSR/ $^{\circ}$ C).

Gain Error Temperature Coefficient

A measure of the change in gain error with changes in temperature. It is expressed as parts per million of full-scale range per degree Celsius (ppm FSR/ $^{\circ}$ C).

Digital-to-Analog Glitch Energy

The impulse injected into the analog output when the input code in the data register changes state. It is normally specified as the area of the glitch in nanovolt-seconds (nV-sec) and is measured when the digital input code is changed by 1 LSB at the major carry transition (0x7FFF to 0x8000), as shown in Figure 28.

Digital Feedthrough

A measure of the impulse injected into the analog output of the DAC from the digital inputs of the DAC but is measured when the DAC output is not updated. It is specified in nanovolt-seconds (nV-sec) and measured with a full-scale code change on the data bus, that is, from all 0s to all 1s, and vice versa.

Power Supply Sensitivity

Indicates how the output of the DAC is affected by changes in the power supply voltage.

DC Crosstalk

The dc change in the output level of one DAC in response to a change in the output of another DAC. It is measured with a full-scale output change on one DAC while monitoring another DAC, and is expressed in least significant bits (LSBs).

DAC-to-DAC Crosstalk

The glitch impulse transferred to the output of one DAC due to a digital code change and subsequent output change of another DAC. This includes both digital and analog crosstalk. It is measured by loading one of the DACs with a full-scale code change (from all 0s to all 1s, and vice versa) with $\overline{\text{LDAC}}$ low and monitoring the output of another DAC. The energy of the glitch is expressed in nanovolt-seconds (nV-sec).

Channel-to-Channel Isolation

The ratio of the amplitude of the signal at the output of one DAC to a sine wave on the reference input of another DAC. It is measured in decibels (dB).

Reference Temperature Coefficient

A measure of the change in the reference output voltage with a change in temperature. It is expressed in parts per million per degree Celsius (ppm/ $^{\circ}$ C).

Digital Crosstalk

A measure of the impulse injected into the analog output of one DAC from the digital inputs of another DAC but is measured when the DAC output is not updated. It is specified in nanovolt-seconds (nV-sec) and measured with a full-scale code change on the data bus; that is, from all 0s to all 1s, and vice versa.

Thermal Hysteresis

The change of reference output voltage after the device is cycled through temperatures from -40°C to $+85^{\circ}\text{C}$ and back to -40°C . This is a typical value from a sample of parts put through such a cycle.

THEORY OF OPERATION

The AD5744R is a quad, 14-bit, serial input, bipolar voltage output DAC that operates from supply voltages of $\pm 11.4\text{ V}$ to $\pm 16.5\text{ V}$ and has a buffered output voltage of up to $\pm 10.5263\text{ V}$. Data is written to the AD5744R in a 24-bit word format via a 3-wire serial interface. The AD5744R also offers an SDO pin that is available for daisy chaining or readback.

The AD5744R incorporates a power-on reset circuit that ensures that the data registers are loaded with 0x0000 at power-up. The AD5744R features a digital I/O port that can be programmed via the serial interface, an analog die temperature sensor, on-chip 10 ppm/ $^{\circ}\text{C}$ voltage reference, on-chip reference buffers, and per channel digital gain and offset registers.

DAC ARCHITECTURE

The DAC architecture of the AD5744R consists of a 14-bit current mode segmented R-2R DAC. The simplified circuit diagram for the DAC section is shown in Figure 39.

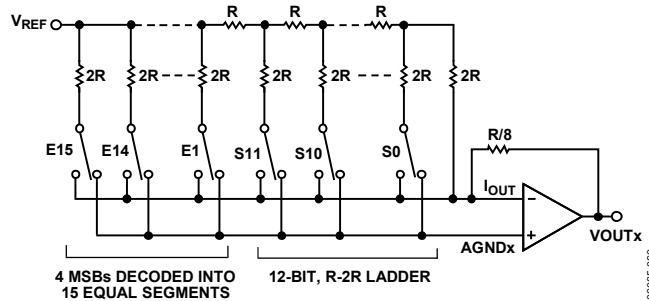

Figure 39. DAC Ladder Structure

The four MSBs of the 14-bit data-word are decoded to drive 15 switches, E1 to E15. Each of these switches connects one of the 15 matched resistors to either AGNDx or IOUT. The remaining 12 bits of the data-word drive Switch S0 to Switch S11 of the 12-bit R-2R ladder network.

REFERENCE BUFFERS

The AD5744R can operate with either an external or an internal reference. The reference inputs (REFAB and REFC) have an input range of up to 7 V. This input voltage is then used to provide a buffered positive and negative reference for the DAC cores. The positive reference is given by

$$+V_{REF} = 2 \times V_{REFIN}$$

The negative reference to the DAC cores is given by

$$-V_{REF} = -2 \times V_{REFIN}$$

These positive and negative reference voltages (along with the gain register values) define the output ranges of the DACs.

SERIAL INTERFACE

The AD5744R is controlled over a versatile 3-wire serial interface that operates at clock rates of up to 30 MHz and is compatible with SPI, QSPI™, MICROWIRE™, and DSP standards.

Input Shift Register

The input shift register is 24 bits wide. Data is loaded into the device, MSB first, as a 24-bit word under the control of a serial clock input, SCLK. The input register consists of a read/write bit, a reserved bit that must be set to 0, three register select bits, three DAC address bits, and 16 data bits, as shown in Table 9. The timing diagram for this operation is shown in Figure 2.

Upon power-up, the data registers are loaded with zero code (0x0000), and the outputs are clamped to 0 V via a low impedance path. The outputs can be updated with the zero code value by asserting either LDAC or CLR. The corresponding output voltage depends on the state of the BIN/2sCOMP pin. If the BIN/2sCOMP pin is tied to DGND, the data coding is twos complement and the outputs update to 0 V. If the BIN/2sCOMP pin is tied to DVCC, the data coding is offset binary and the outputs update to negative full scale. To have the outputs power-up with zero code loaded to the outputs, the CLR pin should be held low during power-up.

Standalone Operation

The serial interface works with both a continuous and noncontinuous serial clock. A continuous SCLK source can be used only if SYNC is held low for the correct number of clock cycles. In gated clock mode, a burst clock containing the exact number of clock cycles must be used, and SYNC must be taken high after the final clock to latch the data. The first falling edge of SYNC starts the write cycle. Exactly 24 falling clock edges must be applied to SCLK before SYNC is brought high again. If SYNC is brought high before the 24th falling SCLK edge, the data written is invalid. If more than 24 falling SCLK edges are applied before SYNC is brought high, the input data is also invalid. The input register addressed is updated on the rising edge of SYNC. For another serial transfer to take place, SYNC must be brought low again. After the end of the serial data transfer, data is automatically transferred from the input shift register to the addressed register.

When the data has been transferred into the chosen register of the addressed DAC, all data registers and outputs can be updated by taking LDAC low.

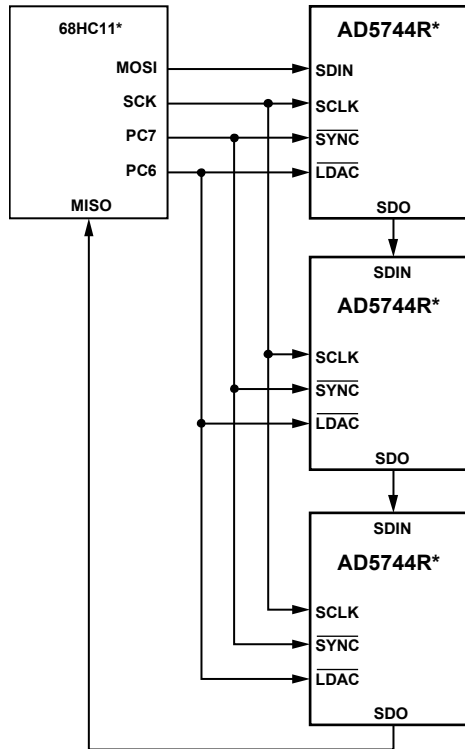

*ADDITIONAL PINS OMITTED FOR CLARITY.

Figure 40. Daisy-Chaining the AD5744R

Daisy-Chain Operation

For systems that contain several devices, the SDO pin can be used to daisy-chain several devices together. This daisy-chain mode can be useful in system diagnostics and in reducing the number of serial interface lines. The first falling edge of SYNC starts the write cycle. The SCLK is continuously applied to the input shift register when SYNC is low. If more than 24 clock pulses are applied, the data ripples out of the shift register and appears on the SDO line. This data is clocked out on the rising edge of SCLK and is valid on the falling edge. By connecting the SDO of the first device to the SDIN input of the next device in the chain, a multidevice interface is constructed. Each device in

the system requires 24 clock pulses. Therefore, the total number of clock cycles must equal $24n$, where n is the total number of AD5744R devices in the chain. When the serial transfer to all devices is complete, SYNC is taken high. This latches the input data in each device in the daisy chain and prevents any further data from being clocked into the input shift register. The serial clock can be a continuous or a gated clock.

A continuous SCLK source can be used only if SYNC is held low for the correct number of clock cycles. In gated clock mode, a burst clock containing the exact number of clock cycles must be used, and SYNC must be taken high after the final clock to latch the data.

Readback Operation

Before a readback operation is initiated, the SDO pin must be enabled by writing to the function register and clearing the SDO disable bit; this bit is cleared by default. Readback mode is invoked by setting the R/W bit to 1 in the serial input register write. With R/W set to 1, Bit A2 to Bit A0, in association with Bit REG2, to Bit REG0, select the register to be read. The remaining data bits in the write sequence are don't care. During the next SPI write, the data appearing on the SDO output contain the data from the previously addressed register. For a read of a single register, the NOP command can be used in clocking out the data from the selected register on SDO. The readback diagram in Figure 4 shows the readback sequence. For example, to read back the fine gain register of Channel A, implement the following sequence:

1. Write 0xA0XXXX to the input register. This write configures the AD5744R for read mode with the fine gain register of Channel A selected. Note that all the data bits, DB15 to DB0, are don't care.
2. Follow with a second write: an NOP condition, 0x00XXXX. During this write, the data from the fine gain register is clocked out on the SDO line; that is, data clocked out contains the data from the fine gain register in Bit DB5 to Bit DB0.

SIMULTANEOUS UPDATING VIA $\overline{\text{LDAC}}$

Depending on the status of both $\overline{\text{SYNC}}$ and $\overline{\text{LDAC}}$, and after data has been transferred into the input register of the DACs, there are two ways to update the data registers and DAC outputs.

Individual DAC Updating

In individual DAC updating mode, $\overline{\text{LDAC}}$ is held low while data is being clocked into the input shift register. The addressed DAC output is updated on the rising edge of $\overline{\text{SYNC}}$.

Simultaneous Updating of All DACs

In simultaneous updating of all DACs mode, $\overline{\text{LDAC}}$ is held high while data is being clocked into the input shift register. All DAC outputs are updated by taking $\overline{\text{LDAC}}$ low any time after $\overline{\text{SYNC}}$ has been taken high. The update then occurs on the falling edge of $\overline{\text{LDAC}}$.

See Figure 41 for a simplified block diagram of the DAC load circuitry.

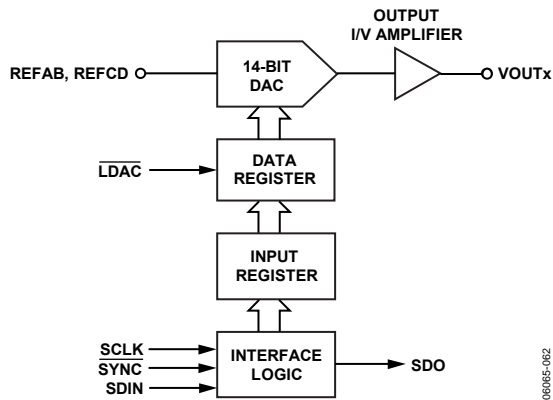

Figure 41. Simplified Serial Interface of Input Loading Circuitry for One DAC Channel

TRANSFER FUNCTION

Table 7 and Table 8 show the ideal input code to output voltage relationship for offset binary data coding and twos complement data coding, respectively.

The output voltage expression for the AD5744R is given by

$$V_{OUT} = -2 \times V_{REFIN} + 4 \times V_{REFIN} \left[\frac{D}{16,384} \right]$$

where:

D is the decimal equivalent of the code loaded to the DAC.

V_{REFIN} is the reference voltage applied at the REFAB and REFCD pins.

ASYNCHRONOUS CLEAR ($\overline{\text{CLR}}$)

$\overline{\text{CLR}}$ is a negative edge triggered clear that allows the outputs to be cleared to either 0 V (twos complement coding) or negative full scale (offset binary coding). It is necessary to maintain $\overline{\text{CLR}}$ low for a minimum amount of time for the operation to complete (see Figure 2). When the $\overline{\text{CLR}}$ signal is returned high, the output remains at the cleared value until a new value is programmed. If $\overline{\text{CLR}}$ is at 0 V at power-on, all DAC outputs are updated with the clear value. A clear can also be initiated through software by writing the command of 0x04XXXX to the AD5744R.

Table 7. Ideal Output Voltage to Input Code Relationship—Offset Binary Data Coding

| Digital Input | | | | Analog Output |
|---------------|------|------|------|---------------------------------|
| MSB | | | LSB | V_{OUT} |
| 11 | 1111 | 1111 | 1111 | $+2 V_{REF} \times (8191/8192)$ |
| 10 | 0000 | 0000 | 0001 | $+2 V_{REF} \times (1/8192)$ |
| 10 | 0000 | 0000 | 0000 | 0 V |
| 01 | 1111 | 1111 | 1111 | $-2 V_{REF} \times (1/8192)$ |
| 00 | 0000 | 0000 | 0000 | $-2 V_{REF} \times (8191/8192)$ |

Table 8. Ideal Output Voltage to Input Code Relationship—Twos Complement Data Coding

| Digital Input | | | | Analog Output |
|---------------|------|------|------|---------------------------------|
| MSB | | | LSB | V_{OUT} |
| 01 | 1111 | 1111 | 1111 | $+2 V_{REF} \times (8191/8192)$ |
| 00 | 0000 | 0000 | 0001 | $+2 V_{REF} \times (1/8192)$ |
| 00 | 0000 | 0000 | 0000 | 0 V |
| 11 | 1111 | 1111 | 1111 | $-2 V_{REF} \times (1/8192)$ |
| 10 | 0000 | 0000 | 0000 | $-2 V_{REF} \times (8191/8192)$ |

REGISTERS

Table 9. Input Shift Register Format

| MSB | | | | | | | | LSB |
|------|------|------|------|------|------|------|------|-------------|
| DB23 | DB22 | DB21 | DB20 | DB19 | DB18 | DB17 | DB16 | DB15 to DB0 |
| R/W | 0 | REG2 | REG1 | REG0 | A2 | A1 | A0 | Data |

Table 10. Input Shift Register Bit Function Descriptions

| Register Bit | Description | | | | | | | | | | | | | | | | | | | | | | | | |
|------------------|---|------|----------------------|------|-----------------|---|---|---|-------------------|---|---|---|---------------|---|---|---|----------------------|---|---|---|--------------------|---|---|---|----------|
| R/W | Indicates a read from or a write to the addressed register | | | | | | | | | | | | | | | | | | | | | | | | |
| REG2, REG1, REG0 | Used in association with the address bits, determines if a read or write operation is to the data register, offset register, gain register, or function register. | | | | | | | | | | | | | | | | | | | | | | | | |
| | <table border="1"> <thead> <tr> <th>REG2</th> <th>REG1</th> <th>REG0</th> <th>Function</th> </tr> </thead> <tbody> <tr> <td>0</td> <td>0</td> <td>0</td> <td>Function register</td> </tr> <tr> <td>0</td> <td>1</td> <td>0</td> <td>Data register</td> </tr> <tr> <td>0</td> <td>1</td> <td>1</td> <td>Coarse gain register</td> </tr> <tr> <td>1</td> <td>0</td> <td>0</td> <td>Fine gain register</td> </tr> </tbody> </table> | REG2 | REG1 | REG0 | Function | 0 | 0 | 0 | Function register | 0 | 1 | 0 | Data register | 0 | 1 | 1 | Coarse gain register | 1 | 0 | 0 | Fine gain register | | | | |
| REG2 | REG1 | REG0 | Function | | | | | | | | | | | | | | | | | | | | | | |
| 0 | 0 | 0 | Function register | | | | | | | | | | | | | | | | | | | | | | |
| 0 | 1 | 0 | Data register | | | | | | | | | | | | | | | | | | | | | | |
| 0 | 1 | 1 | Coarse gain register | | | | | | | | | | | | | | | | | | | | | | |
| 1 | 0 | 0 | Fine gain register | | | | | | | | | | | | | | | | | | | | | | |
| A2, A1, A0 | Decodes the DAC channels | | | | | | | | | | | | | | | | | | | | | | | | |
| | <table border="1"> <thead> <tr> <th>A2</th> <th>A1</th> <th>A0</th> <th>Channel Address</th> </tr> </thead> <tbody> <tr> <td>0</td> <td>0</td> <td>0</td> <td>DAC A</td> </tr> <tr> <td>0</td> <td>0</td> <td>1</td> <td>DAC B</td> </tr> <tr> <td>0</td> <td>1</td> <td>0</td> <td>DAC C</td> </tr> <tr> <td>0</td> <td>1</td> <td>1</td> <td>DAC D</td> </tr> <tr> <td>1</td> <td>0</td> <td>0</td> <td>All DACs</td> </tr> </tbody> </table> | A2 | A1 | A0 | Channel Address | 0 | 0 | 0 | DAC A | 0 | 0 | 1 | DAC B | 0 | 1 | 0 | DAC C | 0 | 1 | 1 | DAC D | 1 | 0 | 0 | All DACs |
| A2 | A1 | A0 | Channel Address | | | | | | | | | | | | | | | | | | | | | | |
| 0 | 0 | 0 | DAC A | | | | | | | | | | | | | | | | | | | | | | |
| 0 | 0 | 1 | DAC B | | | | | | | | | | | | | | | | | | | | | | |
| 0 | 1 | 0 | DAC C | | | | | | | | | | | | | | | | | | | | | | |
| 0 | 1 | 1 | DAC D | | | | | | | | | | | | | | | | | | | | | | |
| 1 | 0 | 0 | All DACs | | | | | | | | | | | | | | | | | | | | | | |
| Data | Data bits | | | | | | | | | | | | | | | | | | | | | | | | |

FUNCTION REGISTER

The function register is addressed by setting the three REG bits to 000. The values written to the address bits and the data bits determine the function addressed. The functions available via the function register are outlined in Table 11 and Table 12.

Table 11. Function Register Options

| REG2 | REG1 | REG0 | A2 | A1 | A0 | DB15 to DB6 | DB5 | DB4 | DB3 | DB2 | DB1 | DB0 |
|------|------|------|----|----|----|--------------------------|----------------------------|--------------|----------|--------------|----------|-------------|
| 0 | 0 | 0 | 0 | 0 | 0 | NOP, data = don't care | | | | | | |
| 0 | 0 | 0 | 0 | 0 | 1 | Don't care | Local ground offset adjust | D1 direction | D1 value | D0 direction | D0 value | SDO disable |
| 0 | 0 | 0 | 1 | 0 | 0 | Clear, data = don't care | | | | | | |
| 0 | 0 | 0 | 1 | 0 | 1 | Load, data = don't care | | | | | | |

Table 12. Explanation of Function Register Options

| Option | Description |
|----------------------------|--|
| NOP | No operation instruction used in readback operations. |
| Local Ground Offset Adjust | Set by the user to enable the local ground offset adjust function. Cleared by the user to disable the local ground offset adjust function (default). See the Design Features section for more information. |
| D0, D1 Direction | Set by the user to enable the D0 and D1 pins as outputs. Cleared by the user to enable the D0 and D1 pins as inputs (default). See the Design Features section for more information. |
| D0, D1 Value | I/O port status bits. Logic values written to these locations determine the logic outputs on the D0 and D1 pins when configured as outputs. These bits indicate the status of the D0 and D1 pins when the I/O port is active as an input. When enabled as inputs, these bits are don't cares during a write operation. |
| SDO Disable | Set by the user to disable the SDO output. Cleared by the user to enable the SDO output (default). |
| Clear | Addressing this function resets the DAC outputs to 0V in twos complement mode and negative full scale in binary mode. |
| Load | Addressing this function updates the data registers and, consequently, the analog outputs. |

DATA REGISTER

The data register is addressed by setting the three REG bits to 010. The DAC address bits select the DAC channel with which the data transfer takes place (see Table 10). The data bits are positioned in DB15 to DB2, as shown in Table 13.

Table 13. Programming the Data Register

| REG2 | REG1 | REG0 | A2 | A1 | A0 | DB15 to DB2 | DB1 | DB0 |
|------|------|------|-------------|----|----|-----------------|-----|-----|
| 0 | 1 | 0 | DAC address | | | 14-bit DAC data | X | X |

COARSE GAIN REGISTER

The coarse gain register is addressed by setting the three REG bits to 011. The DAC address bits select the DAC channel with which the data transfer takes place (see Table 10). The coarse gain register is a 2-bit register that allows the user to select the output range of each DAC as shown in Table 15.

Table 14. Programming the Coarse Gain Register

| REG2 | REG1 | REG0 | A2 | A1 | A0 | DB15 to DB2 | DB1 | DB0 |
|------|------|------|-------------|----|----|-------------|-----|-----|
| 0 | 1 | 1 | DAC address | | | Don't care | CG1 | CG0 |

Table 15. Output Range Selection

| Output Range | CG1 | CG0 |
|-----------------|-----|-----|
| ±10 V (Default) | 0 | 0 |
| ±10.2564 V | 0 | 1 |
| ±10.5263 V | 1 | 0 |

FINE GAIN REGISTER

The fine gain register is addressed by setting the three REG bits to 100. The DAC address bits select the DAC channel with which the data transfer takes place (see Table 10). The AD5744R fine gain register is a 6-bit register that allows the user to adjust the gain of each DAC channel by –8 LSBs to +7.75 LSBs in 0.25 LSB steps, as shown in Table 16 and Table 17. The adjustment is made to both the positive full-scale points and the negative full-scale points simultaneously, with each point adjusted by one-half of one step. The fine gain register coding is twos complement.

Table 16. Programming the Fine Gain Register

| REG2 | REG1 | REG0 | A2 | A1 | A0 | DB15 to DB6 | DB5 | DB4 | DB3 | DB2 | DB1 | DB0 |
|------|------|------|-------------|----|----|-------------|-----|-----|-----|-----|-----|-----|
| 1 | 0 | 0 | DAC address | | | Don't care | FG5 | FG4 | FG3 | FG2 | FG1 | FG0 |

Table 17. Fine Gain Register Options

| Gain Adjustment | FG5 | FG4 | FG3 | FG2 | FG1 | FG0 |
|-------------------------|-----|-----|-----|-----|-----|-----|
| +7.75 LSBs | 0 | 1 | 1 | 1 | 1 | 1 |
| +7.5 LSBs | 0 | 1 | 1 | 1 | 1 | 0 |
| No Adjustment (Default) | 0 | 0 | 0 | 0 | 0 | 0 |
| –7.75 LSBs | 1 | 0 | 0 | 0 | 0 | 1 |
| –8 LSBs | 1 | 0 | 0 | 0 | 0 | 0 |

DESIGN FEATURES

ANALOG OUTPUT CONTROL

In many industrial process control applications, it is vital that the output voltage be controlled during power-up and during brownout conditions. When the supply voltages are changing, the VOUTx pins are clamped to 0 V via a low impedance path. To prevent the output amp from being shorted to 0 V during this time, Transmission Gate G1 is also opened (see Figure 42).

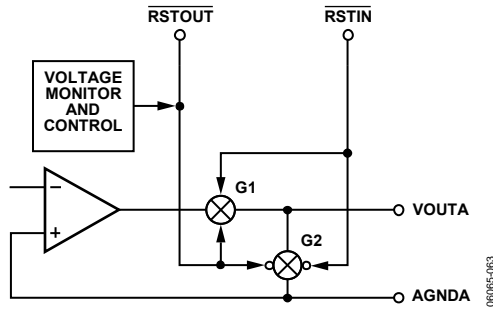

Figure 42. Analog Output Control Circuitry

These conditions are maintained until the power supplies stabilize and a valid word is written to the data register. G2 then opens, and G1 closes. Both transmission gates are also externally controllable via the reset in (RSTIN) control input. For example, if RSTIN is driven from a battery supervisor chip, the RSTIN input is driven low to open G1 and close G2 on power-off or during a brownout. Conversely, the on-chip voltage detector output (RSTOUT) is also available to the user to control other parts of the system. The basic transmission gate functionality is shown in Figure 42.

PROGRAMMABLE SHORT-CIRCUIT PROTECTION

The short-circuit current (I_{SC}) of the output amplifiers can be programmed by inserting an external resistor between the ISCC pin and the PGND pin. The programmable range for the current is 500 μ A to 10 mA, corresponding to a resistor range of 120 k Ω to 6 k Ω . The resistor value is calculated as follows:

$$R \approx \frac{60}{I_{SC}}$$

If the ISCC pin is left unconnected, the short-circuit current limit defaults to 5 mA. It should be noted that limiting the short-circuit current to a small value can affect the slew rate of the output when driving into a capacitive load. Therefore, the value of the short-circuit current that is programmed should take into account the size of the capacitive load being driven.

DIGITAL I/O PORT

The AD5744R contains a 2-bit digital I/O port (D1 and D0). These bits can be configured independently as inputs or outputs and can be driven or have their values read back via the serial interface. The I/O port signals are referenced to DV_{CC} and DGND. When configured as outputs, they can be used as control signals to multiplexers or can be used to control calibration circuitry elsewhere in the system. When configured as inputs, the logic signals from limit switches, for example, can be applied to D0 and D1 and can be read back using the digital interface.

DIE TEMPERATURE SENSOR

The on-chip die temperature sensor provides a voltage output that is linearly proportional to the Celsius temperature scale. Its nominal output voltage is 1.47 V at 25°C die temperature, varying at 5 mV/°C, giving a typical output range of 1.175 V to 1.9 V over the full temperature range. Its low output impedance and linear output simplify interfacing to temperature control circuitry and analog-to-digital converters (ADCs). The temperature sensor is provided as more of a convenience than as a precise feature; it is intended for indicating a die temperature change for recalibration purposes.

LOCAL GROUND OFFSET ADJUST

The AD5744R incorporates a local ground offset adjust feature that, when enabled in the function register, adjusts the DAC outputs for voltage differences between the individual DAC ground pins and the REFGND pin, ensuring that the DAC output voltages are always referenced to the local DAC ground pin. For example, if the AGNDA pin is at +5 mV with respect to the REFGND pin, and VOUTA is measured with respect to AGNDA, a -5 mV error results, enabling the local ground offset adjust feature to adjust VOUTA by +5 mV, thereby eliminating the error.

APPLICATIONS INFORMATION

TYPICAL OPERATING CIRCUIT

Figure 43 shows the typical operating circuit for the AD5744R. The only external components needed for this precision 14-bit DAC are decoupling capacitors on the supply pins and reference inputs and an optional short-circuit current setting resistor. Because the AD5744R incorporates a voltage reference and reference buffers, it eliminates the need for an external bipolar reference and associated buffers, resulting in an overall savings in both cost and board space.

In Figure 43, AV_{DD} is connected to +15 V, and AV_{SS} is connected to -15 V; but AV_{DD} and AV_{SS} can operate with supplies from ± 11.4 V to ± 16.5 V. In Figure 43, $AGND_x$ is connected to REFGND.

Precision Voltage Reference Selection

To achieve the optimum performance from the AD5744R over its full operating temperature range, an external voltage reference must be used. Care must be taken in the selection of a precision voltage reference. The AD5744R has two reference inputs, REFAB and REFC. The voltages applied to the reference inputs are used to provide a buffered positive and negative reference for the DAC cores. Therefore, any error in the voltage reference is reflected in the outputs of the device.

There are four possible sources of error to consider when choosing a voltage reference for high accuracy applications: initial accuracy, temperature coefficient of the output voltage, long term drift, and output voltage noise.

Initial accuracy error on the output voltage of an external reference could lead to a full-scale error in the DAC. Therefore, to minimize these errors, a reference with low initial accuracy error specification is preferred. Choosing a reference with an output trim adjustment, such as the ADR425, allows a system designer to trim system errors out by setting the reference voltage to a voltage other than the nominal. The trim adjustment can also be used at temperature to trim out any error.

Long term drift is a measure of how much the reference output voltage drifts over time. A reference with a tight long-term drift specification ensures that the overall solution remains relatively stable over its entire lifetime.

The temperature coefficient of a reference output voltage affects INL, DNL, and TUE. A reference with a tight temperature coefficient specification should be chosen to reduce the dependence of the DAC output voltage on ambient conditions.

In high accuracy applications, which have a relatively low noise budget, reference output voltage noise must be considered. It is important to choose a reference with as low an output noise voltage as practical for the system resolution that is required. Precision voltage references, such as the ADR435 (XFET® design), produce low output noise in the 0.1 Hz to 10 Hz region. However, as the circuit bandwidth increases, filtering the output of the reference may be required to minimize the output noise.

Table 18. Some Precision References Recommended for Use with the AD5744R

| Part No. | Initial Accuracy (mV Maximum) | Long-Term Drift (ppm Typical) | Temperature Drift (ppm/°C Maximum) | 0.1 Hz to 10 Hz Noise (μ V p-p Typical) |
|----------|----------------------------------|----------------------------------|---------------------------------------|---|
| ADR435 | ± 6 | 30 | 3 | 3.5 |
| ADR425 | ± 6 | 50 | 3 | 3.4 |
| ADR02 | ± 5 | 50 | 3 | 10 |
| ADR395 | ± 6 | 50 | 25 | 5 |
| AD586 | ± 2.5 | 15 | 10 | 4 |

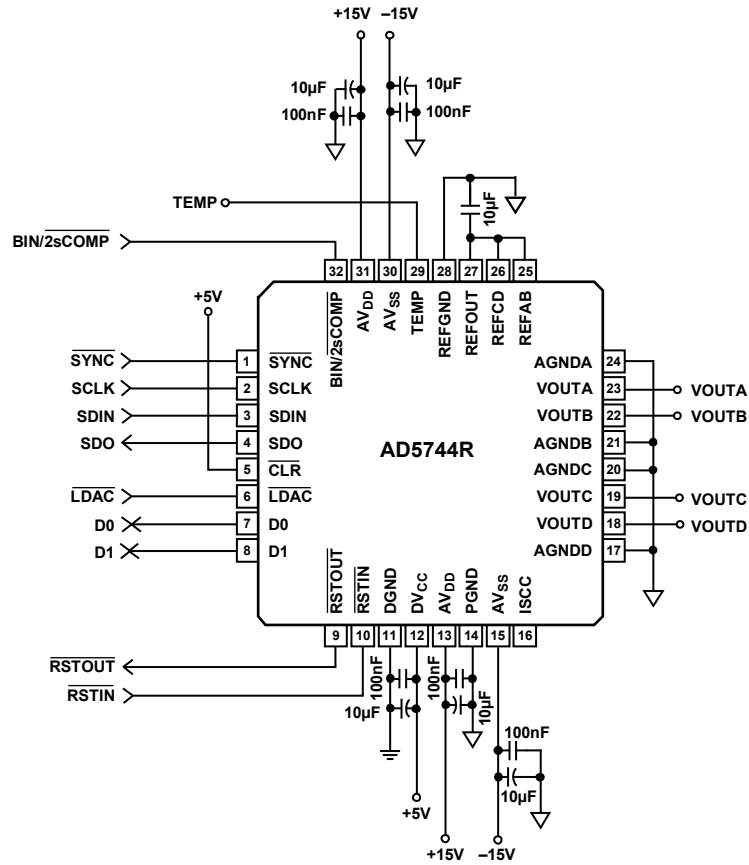

Figure 43. Typical Operating Circuit

060855-064

LAYOUT GUIDELINES

In any circuit where accuracy is important, careful consideration of the power supply and ground return layout helps to ensure the rated performance. Design the PCB on which the AD5744R is mounted such that the analog and digital sections are separated and confined to certain areas of the board. If the AD5744R is in a system where multiple devices require an AGND_x-to-DGND connection, establish the connection at one point only. Establish the star ground point as close as possible to the device. The AD5744R should have ample supply bypassing of 10 μF in parallel with 0.1 μF on each supply located as close to the package as possible, ideally right up against the device. The 10 μF capacitors are of the tantalum bead type. The 0.1 μF capacitor should have low effective series resistance (ESR) and low effective series inductance (ESI), such as the common ceramic types that provide a low impedance path to ground at high frequencies to handle transient currents due to internal logic switching.

The power supply lines of the AD5744R should use as large a trace as possible to provide low impedance paths and reduce the effects of glitches on the power supply line. Shield fast-switching signals, such as clocks with digital ground to avoid radiating noise to other parts of the board; they should never be run near the reference inputs. A ground line routed between the SDIN and SCLK lines helps reduce cross-talk between them. (A ground line is not required on a multi-layer board because it has a separate ground plane; however, it is helpful to separate the lines.) It is essential to minimize noise on the reference inputs because it couples through to the DAC output. Avoid crossover of digital and analog signals. Run traces on opposite sides of the board at right angles to each other to reduce the effects of feed-

through on the board. A microstrip technique is recommended but not always possible with a double-sided board. In this technique, the component side of the board is dedicated to the ground plane, and the signal traces are placed on the solder side.

GALVANICALLY ISOLATED INTERFACE

In many process control applications, it is necessary to provide an isolation barrier between the controller and the unit being controlled to protect and isolate the controlling circuitry from any hazardous common-mode voltages that may occur. Isocouplers provide voltage isolation in excess of 2.5 kV. The serial loading structure of the AD5744R makes it ideal for isolated interfaces because the number of interface lines is kept to a minimum. Figure 44 shows a 4-channel isolated interface to the AD5744R using an ADuM1400 *iCoupler*® product. For more information on *iCoupler* products, refer to www.analog.com.

MICROPROCESSOR INTERFACING

Microprocessor interfacing to the AD5744R is accomplished using a serial bus that uses standard protocol that is compatible with microcontrollers and DSP processors. The communications channel is a 3-wire (minimum) interface consisting of a clock signal, a data signal, and a synchronization signal. The AD5744R requires a 24-bit data-word with data valid on the falling edge of SCLK.

For all the interfaces, a DAC output update can be performed automatically when all the data is clocked in, or it can be done under the control of $\overline{\text{LDAC}}$. The contents of the data register can be read using the readback function.

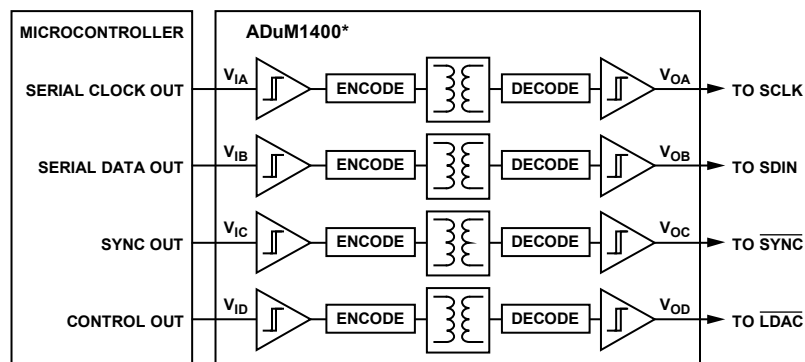
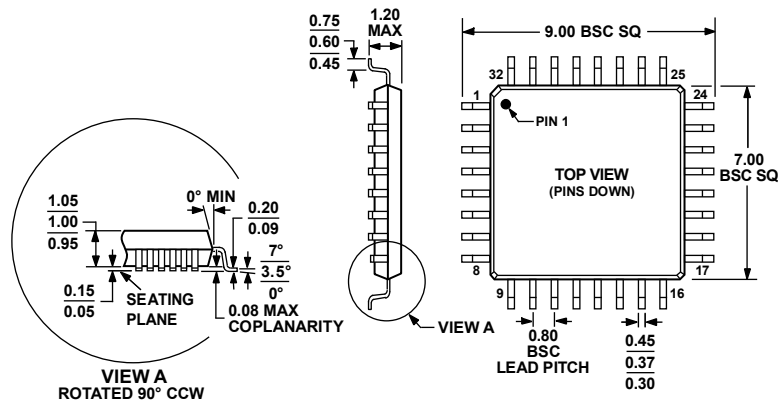

Figure 44. Isolated Interface

OUTLINE DIMENSIONS



COMPLIANT TO JEDEC STANDARDS MS-026-ABA

Figure 45. 32-Lead Thin Plastic Quad Flat Package [TQFP] (SU-32-2)

Dimensions shown in millimeters

020607-A

ORDERING GUIDE

| Model ¹ | Function | INL | Temperature Range | Internal Reference | Package Description | Package Option |
|--------------------|-----------------|----------------|-------------------|--------------------|---------------------|----------------|
| AD5744RCSUZ | Quad 14-Bit DAC | ±1 LSB Maximum | -40°C to +85°C | +5 V | 32-Lead TQFP | SU-32-2 |
| AD5744RCSUZ-REEL7 | Quad 14-Bit DAC | ±1 LSB Maximum | -40°C to +85°C | +5 V | 32-Lead TQFP | SU-32-2 |

¹ Z = RoHS Compliant Part.

NOTES

NOTES



Компания «ЭлектроПласт» предлагает заключение долгосрочных отношений при поставках импортных электронных компонентов на взаимовыгодных условиях!

Наши преимущества:

- Оперативные поставки широкого спектра электронных компонентов отечественного и импортного производства напрямую от производителей и с крупнейших мировых складов;
- Поставка более 17-ти миллионов наименований электронных компонентов;
- Поставка сложных, дефицитных, либо снятых с производства позиций;
- Оперативные сроки поставки под заказ (от 5 рабочих дней);
- Экспресс доставка в любую точку России;
- Техническая поддержка проекта, помощь в подборе аналогов, поставка прототипов;
- Система менеджмента качества сертифицирована по Международному стандарту ISO 9001;
- Лицензия ФСБ на осуществление работ с использованием сведений, составляющих государственную тайну;
- Поставка специализированных компонентов (Xilinx, Altera, Analog Devices, Intersil, Interpoint, Microsemi, Aeroflex, Peregrine, Syfer, Eurofarad, Texas Instrument, Miteq, Cobham, E2V, MA-COM, Hittite, Mini-Circuits, General Dynamics и др.);

Помимо этого, одним из направлений компании «ЭлектроПласт» является направление «Источники питания». Мы предлагаем Вам помощь Конструкторского отдела:

- Подбор оптимального решения, техническое обоснование при выборе компонента;
- Подбор аналогов;
- Консультации по применению компонента;
- Поставка образцов и прототипов;
- Техническая поддержка проекта;
- Защита от снятия компонента с производства.



Как с нами связаться

Телефон: 8 (812) 309 58 32 (многоканальный)

Факс: 8 (812) 320-02-42

Электронная почта: org@eplast1.ru

Адрес: 198099, г. Санкт-Петербург, ул. Калинина, дом 2, корпус 4, литера А.