

AFE5804EVM

The AFE5804EVM is an evaluation tool designed for the ultrasound analog front-end (AFE) device AFE5804. In order to deserialize the outputs of the AFE5804, use of the ADSDeSer-50EVM during evaluation is also recommended.

Contents

1	Introduction	2
	1.1 Features.....	2
	1.2 Power Supplies	2
	1.3 Indicators.....	2
2	Board Configuration	4
	2.1 I/O and Power Connectors	4
	2.2 Jumpers and Setup.....	5
	2.3 Test Points.....	6
3	Board Operation	7
	3.1 Software Installation and Operation	7
	3.2 Hardware Setup.....	9
	3.3 Clock Selection	10
	3.4 Data Analysis	10
4	Schematics and Layout.....	11
	4.1 Schematics	11
	4.2 PCB Layout	11
	4.3 Bill of Materials	19
5	Typical Performance	22
Appendix A	TSW1100 for Evaluating AFE5804/5	23

List of Figures

1	AFE5804EVM LED Locations.....	3
2	AFE5804EVM I/O Connectors and Locations	4
3	Locations of Jumpers, JTAG, and Switches on the AFE5804EVM	5
4	Default Setup for Jumpers.....	5
5	AFE5804EVM USB SPI Interface for TGC Mode	7
6	AFE5804EVM USB SPI Interface for CW Mode.....	8
7	AFE5804EVM USB SPI Interface for ADC Setup	9
8	Typical AFE5804 Bench Setup	10
9	Clock Selection Jumper Configurations	10
10	Top Layer, Signal.....	11
11	Inner Layer 1, Ground	12
12	Inner Layer 2, Signal.....	13
13	Inner Layer 3, Power.....	14
14	Inner Layer 4, Ground	15
15	Bottom Layer, Signal.....	16
16	Top Silk Screen Layer	17
17	Bottom Silk Screen Layer	18
18	Typical Performances of AFE5804.....	22
A-1	TSW1100 Interface	24
A-2	Analysis of Noncoherent Sampled Data	25

SPI is a trademark of Motorola, Inc..

List of Tables

1	AFE5804EVM Default Settings When Powered On.....	9
2	Channel-to-Channel Matching Between the AFE5804EVM and ADSDDeSER-50EVM.....	10
3	Bill of Materials	19

1 Introduction

The AFE5804 includes an 8-channel, voltage-controlled amplifier (VCA) and an 8-channel, 50-MSPS analog-to-digital converter (ADC). The outputs of the ADC are 8-channel LVDS outputs, which can be deserialized by the ADSDDeSer-50EVM. The AFE5804 evaluation module (EVM) provides an easy way to examine the performance and functionalities of AFE5804.

1.1 Features

- Characterizes the AFE5804
- Supports CW functionalities test
- Provides 8-channel, low-voltage differential signal (LVDS) outputs from the ADC
- Compatible with the standard TI LVDS deserializer ADSDDeSer-50EVM
- Communicates with a personal computer (PC) through a USB interface
- RS-232 interface also can be configured in case users wish to control the AFE5804 with a microcontroller. MSP430 programming is required.
- Includes multiple power management solutions for the AFE5804 and other devices.
- Onboard Vcntl generator (0 V - 1.2 V).

1.2 Power Supplies

The AFE5804EVM requires only ± 5 -V power supplies for operation.

1.3 Indicators

The AFE5804EVM has four LEDs onboard as shown in [Figure 1](#). The states of these LEDs demonstrate the normal operation of the AFE5804EVM.

- LED1, LED2: +3.3-VA and +3.3-VD power supply indicators. They show the normal operation of 3.3-V power regulators.
- LED 3: MCU operation indicator. Flashing state can indicate the normal operation of the MSP430 when the MSP430 is appropriately programmed.
- LED 4: 1.8-V power indicators

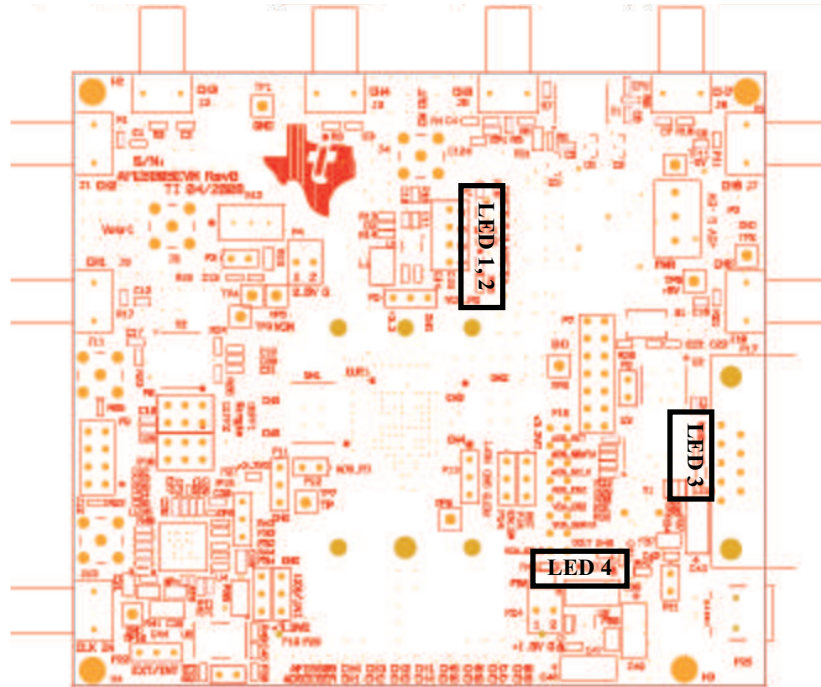

Figure 1. AFE5804EVM LED Locations

2 Board Configuration

This section describes in detail the locations and functionalities of inputs, outputs, jumpers, and test points of the AFE5804EVM.

2.1 I/O and Power Connectors

Pin A1 of the AFE5804 is marked by a white dot on its package as well as a white dot on the board. The positions and functions of the AFE5804EVM connectors are discussed in this section.

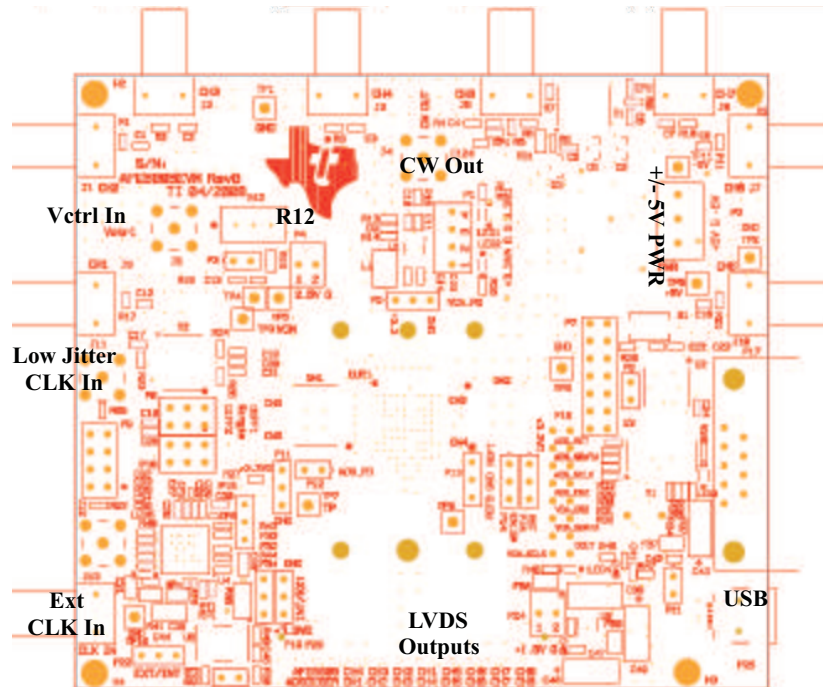

Figure 2. AFE5804EVM I/O Connectors and Locations

- Analog Inputs Ch1-Ch8 (J1-J3, J5-J7, J9, J10): Single-ended analog signal inputs with 50- Ω termination and AC-coupling
- CW Output (J4): CW output after I/V translator
- Vctrl Input (J8 optional): VCA gain control voltage of AFE5804, 0 V to 1.2 V, when this SMA connector is used, shunt P3 must be removed. .
- Low-Jitter CLK Source Input (J11): This input accepts clocks with low-jitter noise, such as HP8644 output. 20- to 50-MHz, 50% duty-cycle clock with 1- to 2-Vrms amplitude can be used. When J11 is used, ensure that shunts P18, P23, and P22 are removed.
- External CLK Input (J13): ADC Clock input, such as FPGA outputs. However, the AFE5804 does not achieve satisfactory performances due to the high-jitter noise of the clock.
- ± 5 -V PWR connector (P2): Power supply input
- Regulated power supply outputs (P1, P4, and P24): 3.3-VA, 3.3-VD, 2.5-VA, 1.8-VD outputs. Connectors need to be installed.
- RS-232 Input (P17): PC serial port interface for setting AFE5804
- USB input (P25): USB interface to control the AFE5804 (default)
- LVDS Outputs Ch1-Ch8 (P26): Differential LVDS data outputs
- R12 is used to adjust the onboard Vctrl from 0 V to 1.2 V. P3 must be shorted when onboard Vctrl is used.

2.2 Jumpers and Setup

In the following detailed description, the board has been set to default mode (see [Figure 3](#)).

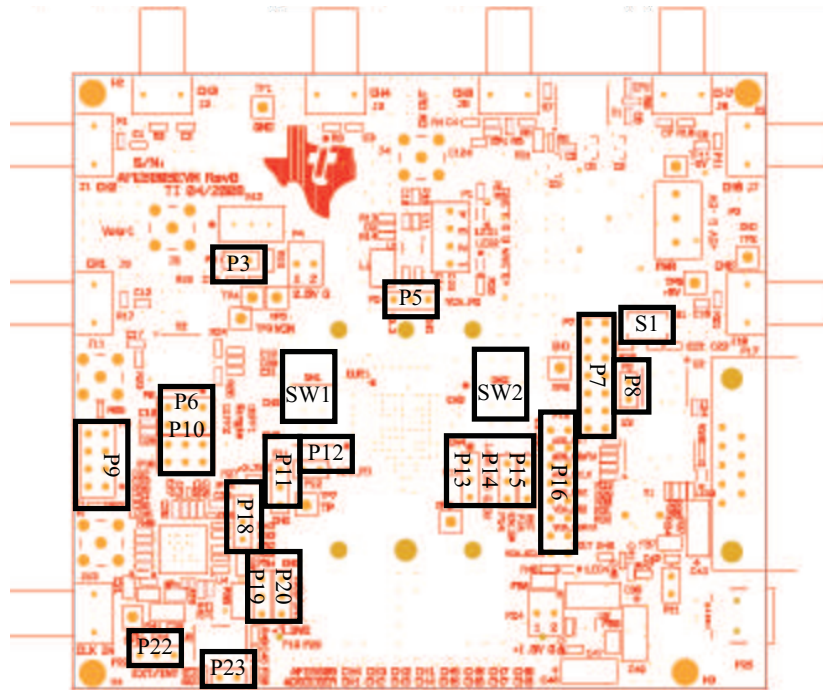

Figure 3. Locations of Jumpers, JTAG, and Switches on the AFE5804EVM

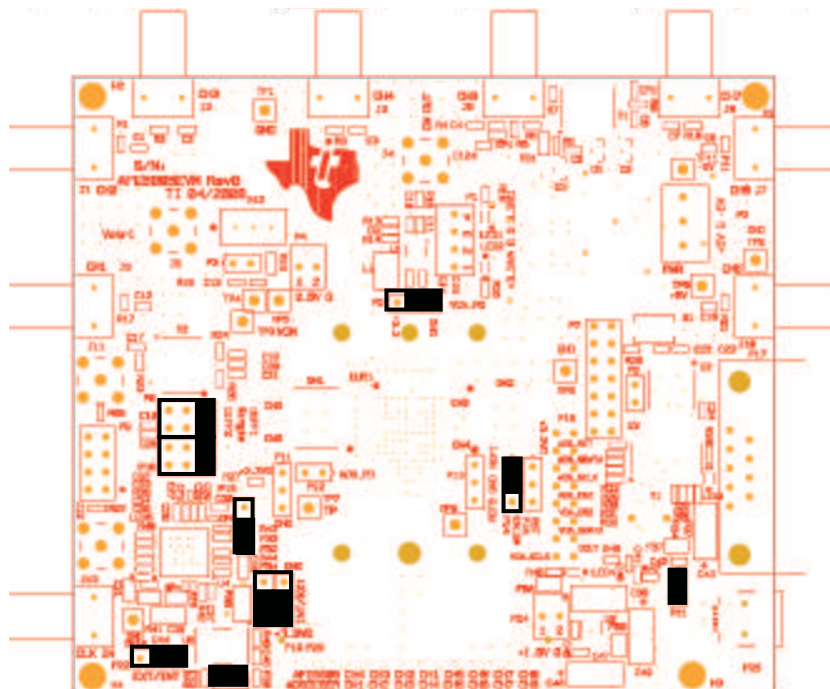

Figure 4. Default Setup for Jumpers

- P5: Power-down pin for the VCA section of the AFE5804. Grounded (default mode) or High (+3.3 VD) for power-down mode.
- P6, P10: AFE5804 ADC clock input selection: Transformer-based differential clock, single-ended LVCMOS clock, or future clock option (needs U4 for support). The default mode uses the

transformer-based differential clock.

- P7: MSP430 microcontroller JTAG interface
- P8: MAX3221 (RS-232) power-off jumper. When the jumper is removed, MAX3221 is completely powered off. In the default mode, the jumper is uninstalled because the USB interface is used.
- P9: SPI™ interface for U4.
- P11: TI internal use. Default is floating.
- P12: Power-down pin for ADS. Active High (+3.3 VD). Floating for default mode.
- P13: External ADS reference voltage inputs. Floating in the internal reference mode.
- P14: EN_SM: In the default mode, P14 connects to +3.3 VD, and the state machine is enabled. The AFE5804 is operated using only one SPI port (ADS SPI port).
- P15: RST pin; connects to H4 in the default mode through 0-Ω resistors.
- P16: Debug port for monitoring VCA and ADS SPI signals.
- P19: TI internal use. Connects to 3.3 VD.
- P20: INT/EXT reference mode selection. +3.3 VD for the internal reference mode (default); GND for the external reference mode.
- P22: Uses onboard 40-MHz clock or external clock through J13. The default mode uses the onboard clock
- P23: Power-on onboard 40-MHz clock generator. Default is on.
- P18: Because U4 is uninstalled, this jumper must be set as [Figure 4](#) shows
- S1: MSP430 reset button
- SW1, SW2: CW outputs summation switch. Individual CW output current can be summed through the I/V translator U1 when its corresponding switch is set to ON.

2.3 Test Points

Multiple test points are provided on the EVM. Detail descriptions follow. Under normal operation mode, it is unnecessary to measure voltages at most of these test points.

- TP1: GND
- TP2: GND
- TP3: VCM
- TP4: Vcntl test point
- TP5: GND
- TP6: GND
- TP7: Test point, TI internal only
- TP8: +5 V
- TP9: CM
- TP10: GND
- TP11: -5 V

3 Board Operation

This section describes how to operate the AFE5804EVM for evaluation purposes. Both software and hardware installation and operation are discussed.

3.1 Software Installation and Operation

The AFE5804EVM ships with the AFE5804EVM USB SPI software and AFE58XXEVM driver. Run the AFE58XXEVM Driver install.exe and the setup.exe to install the driver and software, respectively. The personal computer (PC) recognizes the EVM after software installation.

To launch the software after successful installation, click:

Start Menu → All Programs → Texas Instruments → AFE5804EVM USB SPI → AFE5804EVM USB SPI

Three different modes are shown in [Figure 5](#), [Figure 6](#), and [Figure 7](#).

The software updates the AFE5804 registers as soon as users change any current setup (i.e., the program sends out new register values due to any value change). It is recommended that users change at least one register value before measurement. Therefore, the register values in a device can be synchronized to the displayed values on the software interface.

In most cases, users only need to change the VCA setup. The ADC setup can remain the same as the integrated circuit (IC) is powered up.

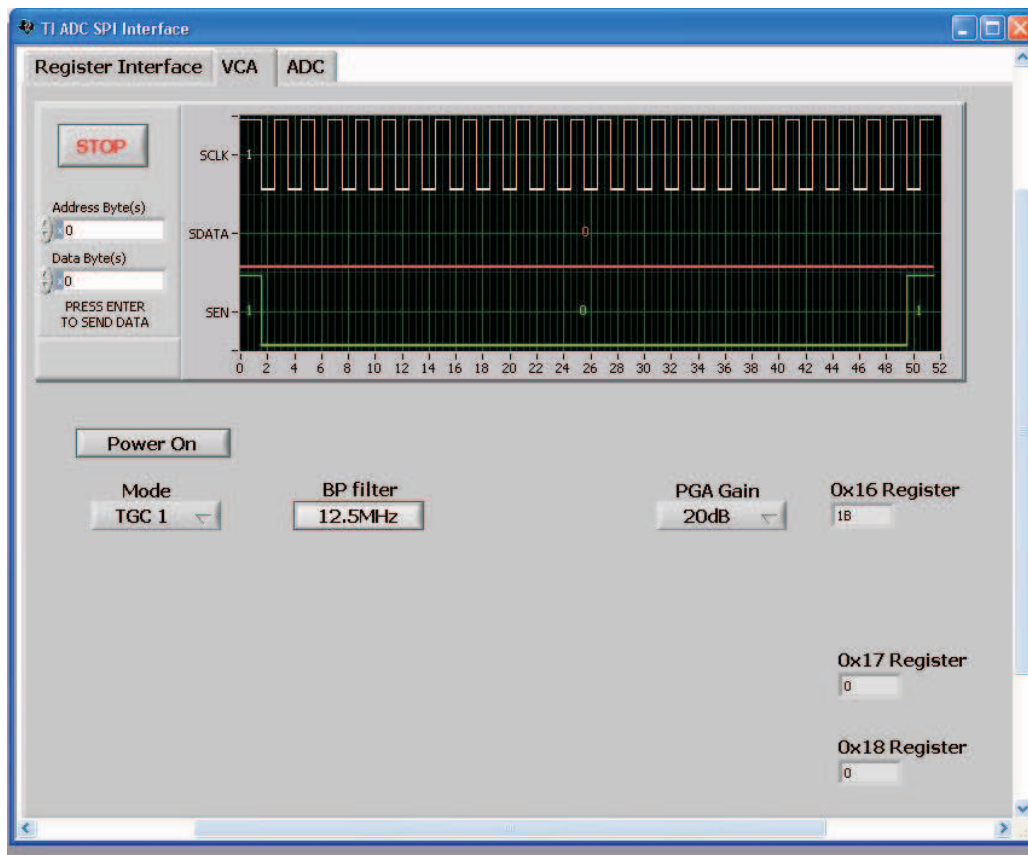

Figure 5. AFE5804EVM USB SPI Interface for TGC Mode

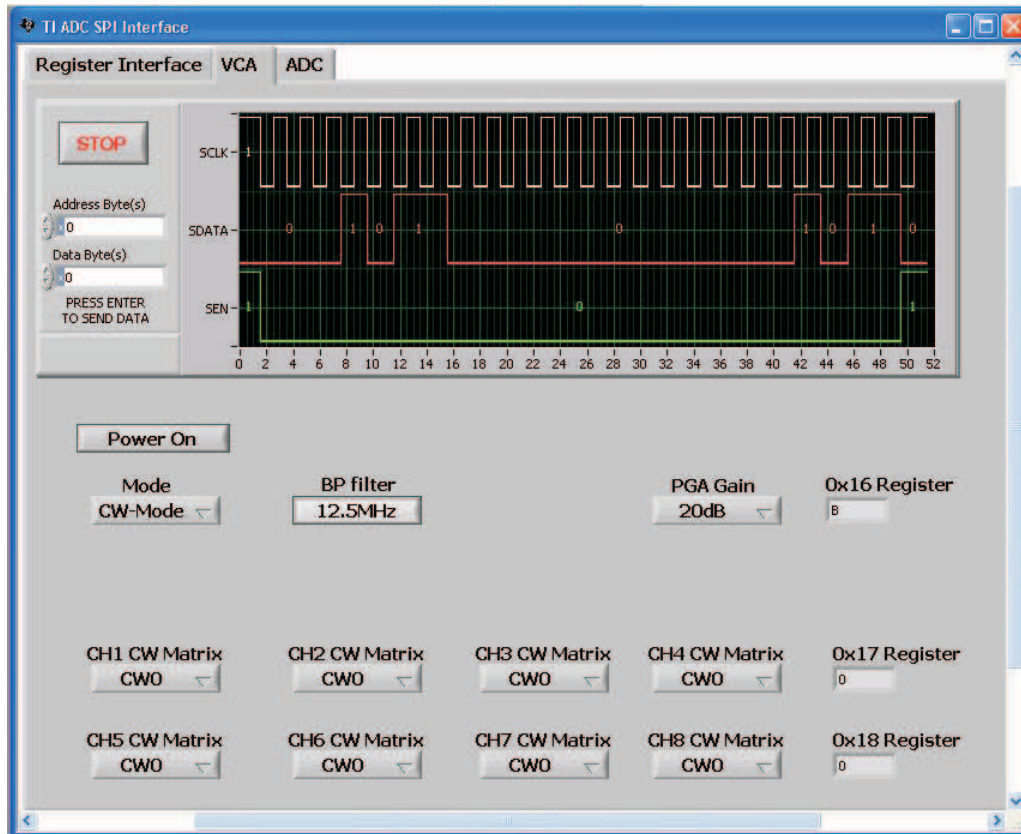

Figure 6. AFE5804EVM USB SPI Interface for CW Mode

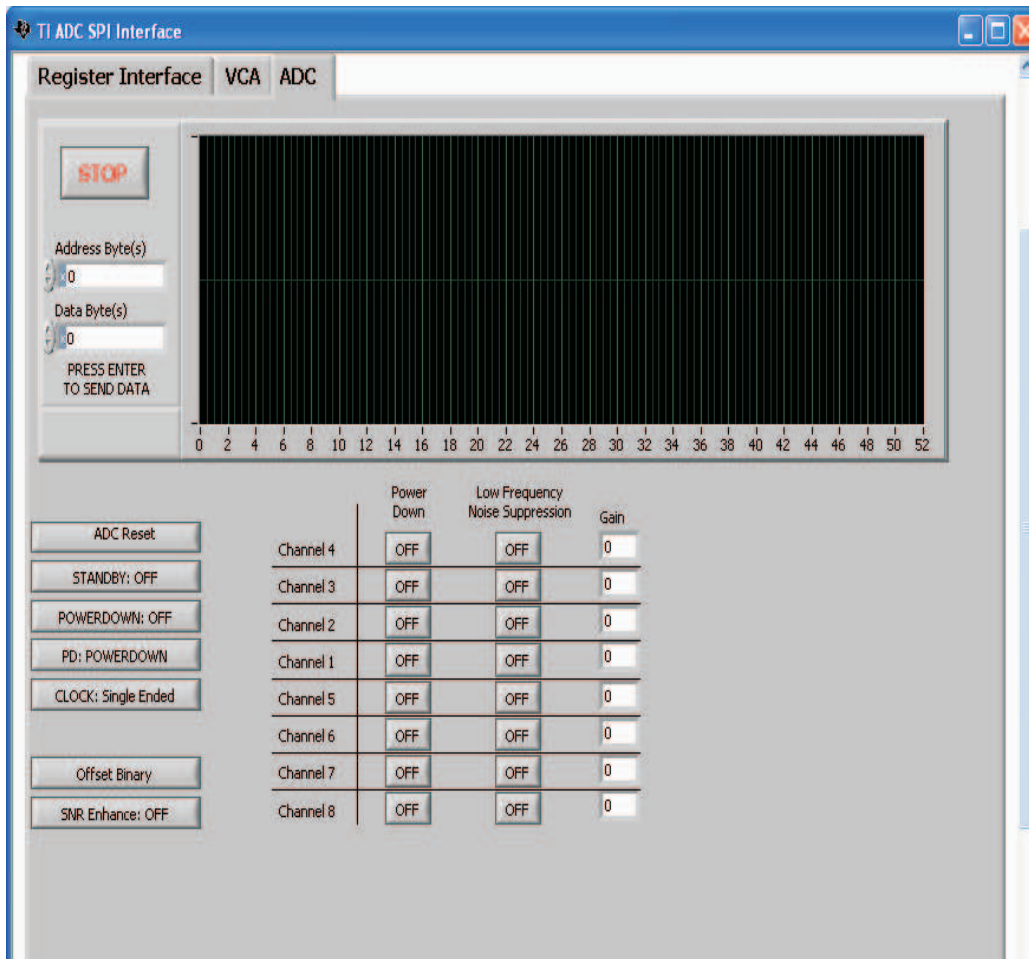

Figure 7. AFE5804EVM USB SPI Interface for ADC Setup

3.2 Hardware Setup

When the AFE5804EVM is powered on in the default mode, the AFE5804 is set as described in Table 1.

Table 1. AFE5804EVM Default Settings When Powered On

VCA	ADS
TGC mode 1	Single End Clock
PGA = 20 dB	Digital Gain = 0
Filter = 17 MHz	Other parameters are as stated in data sheet

Initial measurements can be made under these default settings. See the AFE5804 data sheet ([SBOS442](#)) for additional settings.

As previously mentioned, the deserializer ADSDeSER-50EVM is required. See details in the ADSDeSER-50EVM user's guide ([SBAU091](#)). An example bench setup is shown in Figure 7. Band-pass filters are required for signal source in order to ensure the correct SNR measurements of the AFE5804.

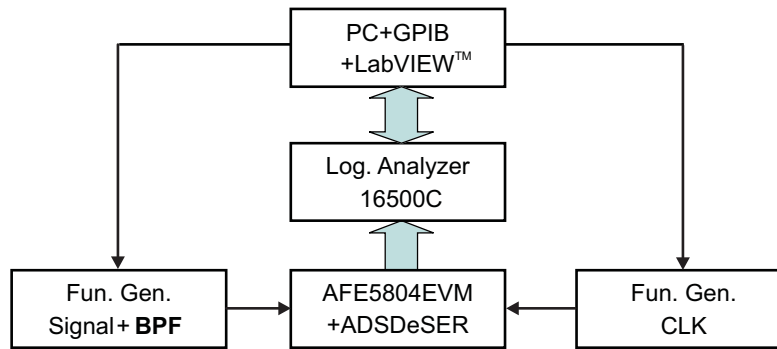

(LabVIEW is a trademark of National Instruments Corporation.)

Figure 8. Typical AFE5804 Bench Setup

The channel order of the AFE5804 outputs is not the same as that of the ADS527x outputs. Consequently, the channel number on the ADSDeSER-50EVM or AFE5804EVM can be misleading. [Table 1](#) provides channel-to-channel sequence matching between the ADSDeSER-50EVM and the AFE5804EVM.

Table 2. Channel-to-Channel Matching Between the AFE5804EVM and ADSDeSER-50EVM

AFE5804	FCLK	CH4	CH3	CH2	CH1	CH5	CH6	CH7	CH8	LCLK
ADSDeSER	FCLK	CH1	CH2	CH3	CH4	CH5	CH6	CH7	CH8	LCLK

For example, when an analog signal is present on CH1 of the AFE5804EVM, the corresponding 12-bit digital output can be seen on CH4 of the ADSDeSER-50EVM.

3.3 Clock Selection

The AFE5804 can be clocked through a transformer-based differential clock, single-ended clock, or future clock input options provided by U4 as [Figure 9](#) shows.

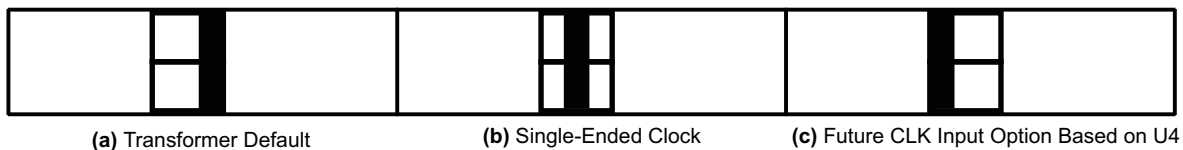

Figure 9. Clock Selection Jumper Configurations

The clock source of the EVM can be the onboard 40-MHz clock, HP8644 low-jitter clock source, or external clock source. The best performance of this EVM is achieved when the low-jitter clock source HP8644 is used. P22, P23, and P18 must be removed in order to disable the onboard clock.

When HP8644 or similar clock sources are unavailable, the onboard 40-MHz clock is the desirable source. The jumpers P22, P23, and P18 must be configured as shown in [Figure 4](#) (i.e., the default setup for AFE5804EVM). In this mode, the transformer-based differential clock is used.

3.4 Data Analysis

Based on the data file acquired by a logic analyzer, the performance of AFE5804 can be evaluated.

Appendix A provides one solution (TI TSW1100 software) to analyze the data file captured by a logic analyzer. Coherent sampling is recommended but is not mandatory. Due to the frequency accuracy requirement of coherence sampling, two HP8644s are required for generating an ADC clock and analog signal. For most users, this may be infeasible. Data analysis based on windowing is a more suitable approach.

4 Schematics and Layout

This section provides the schematics, the AFE5804EVM board layout, and the bill of materials.

4.1 Schematics

The schematics appear at the end of the document.

4.2 PCB Layout

The AFE5804EVM uses a six-layer printed-circuit board. The following figures show each layer.

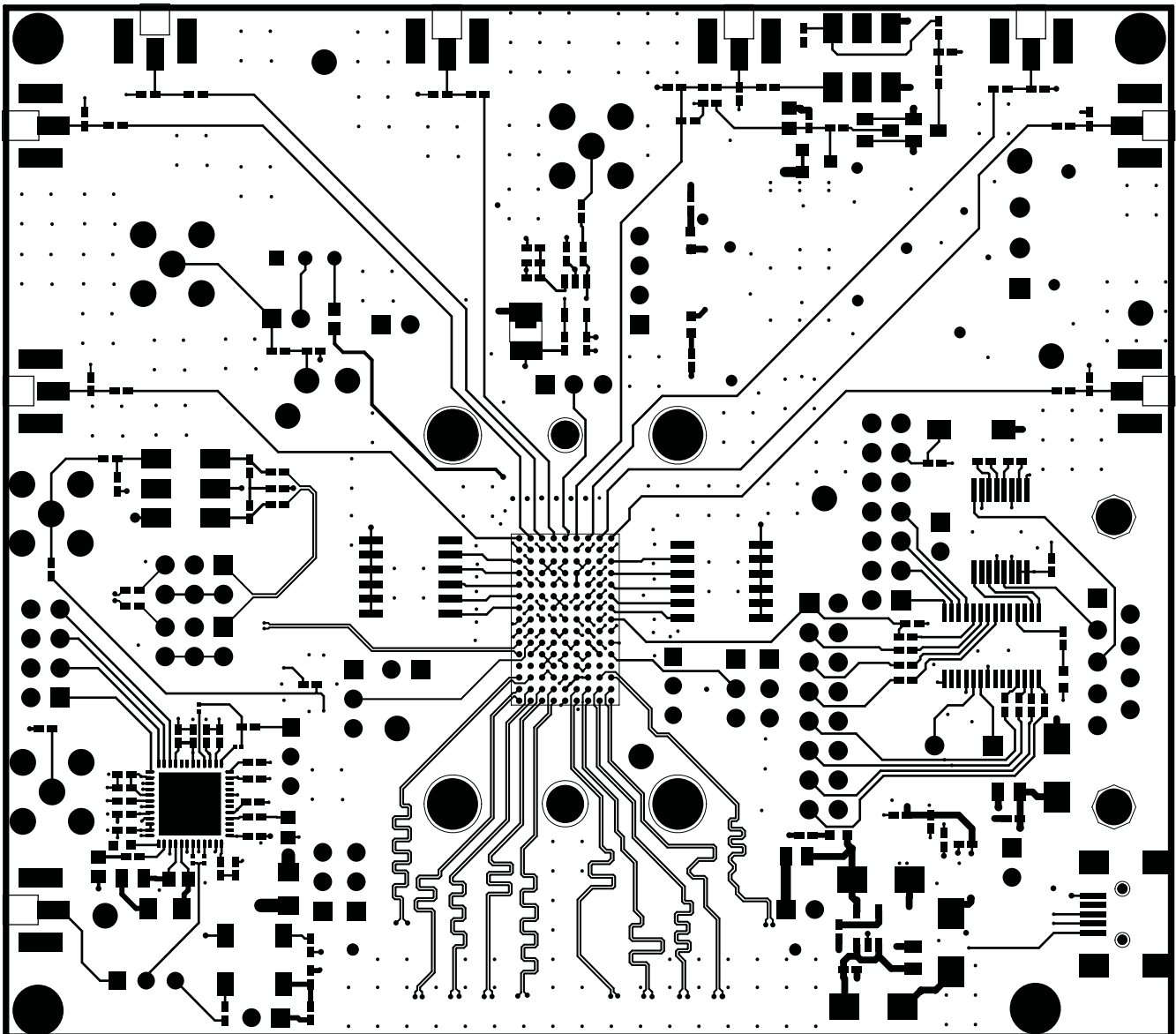

Figure 10. Top Layer, Signal

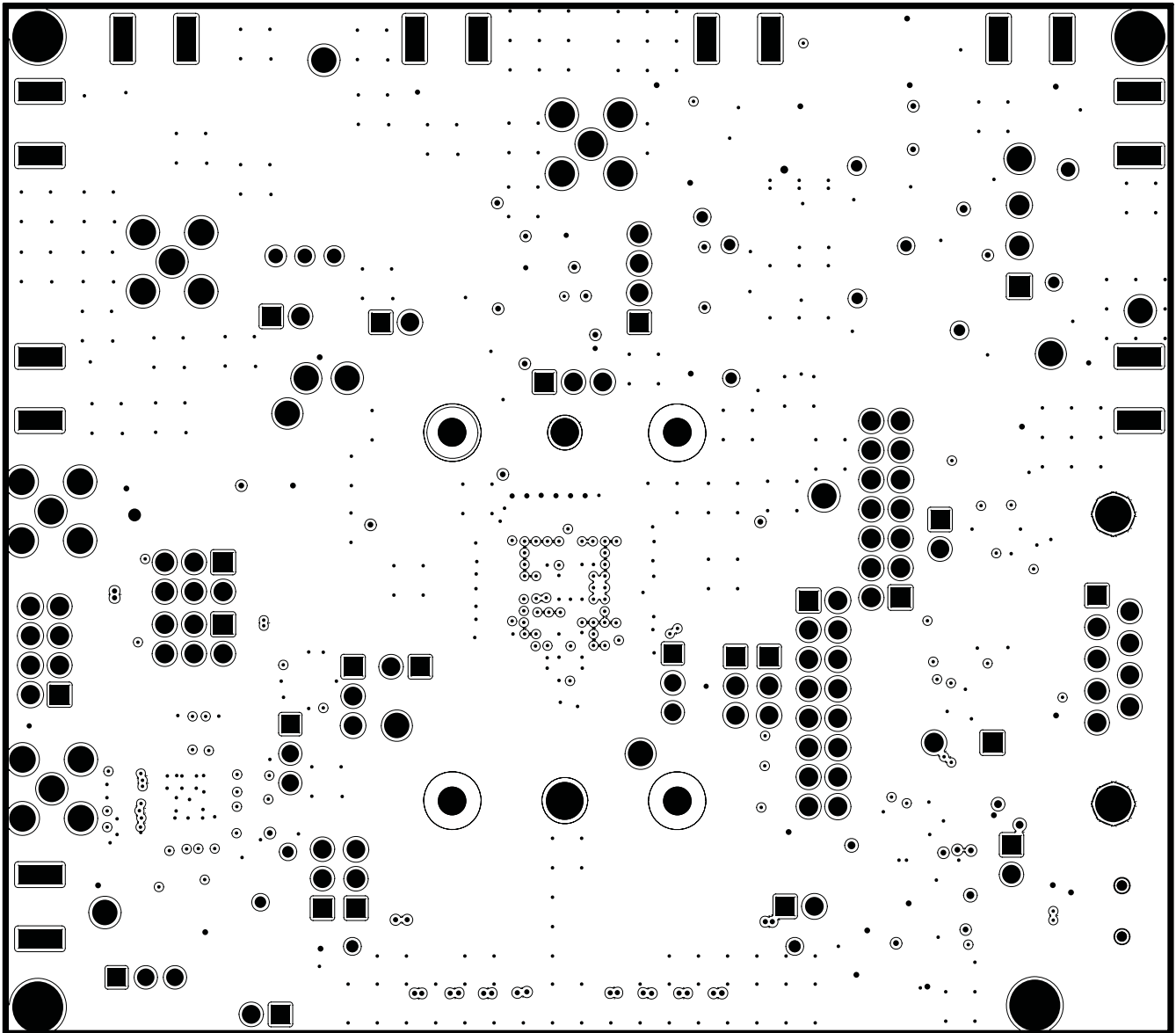

Figure 11. Inner Layer 1, Ground

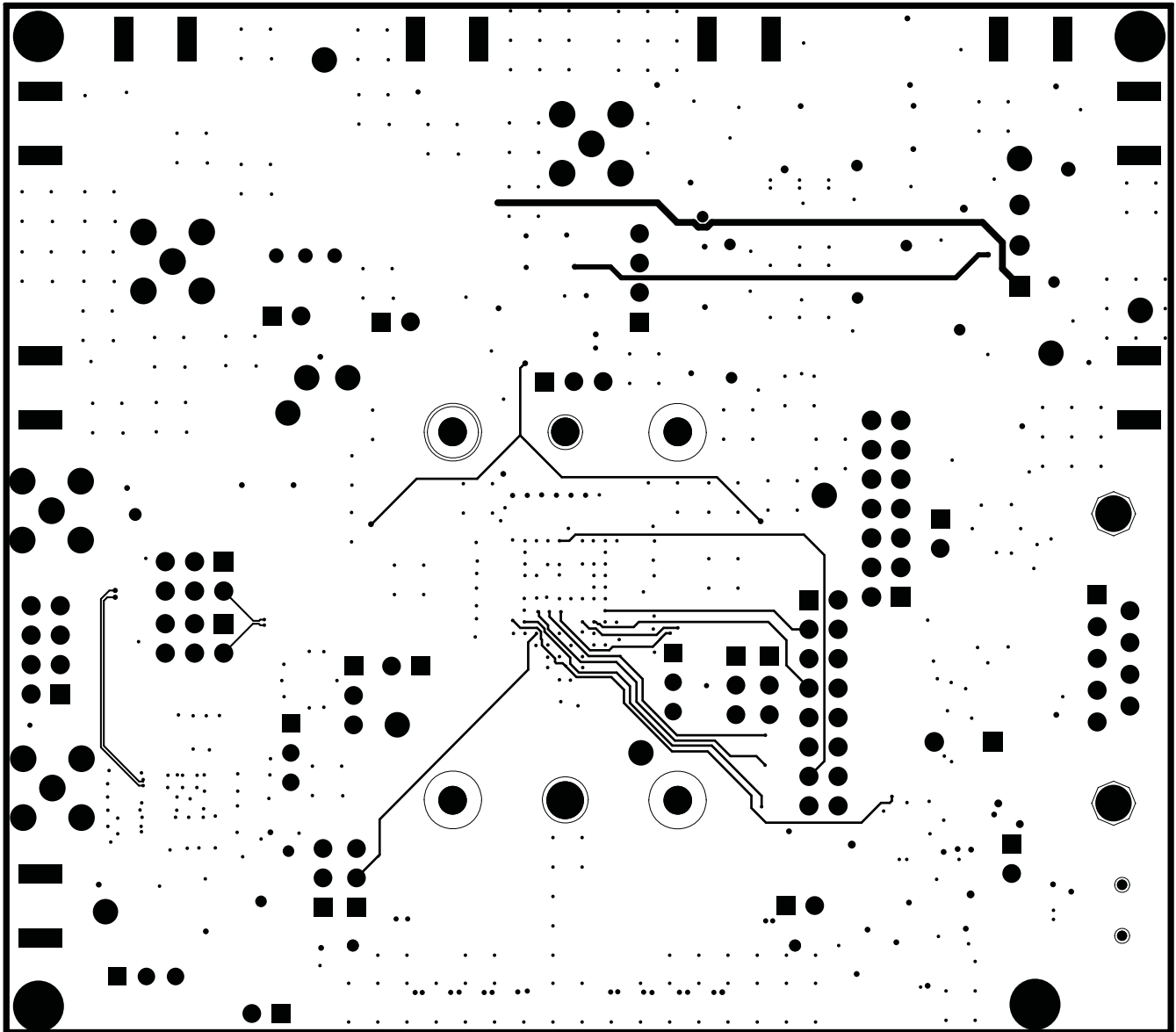

Figure 12. Inner Layer 2, Signal

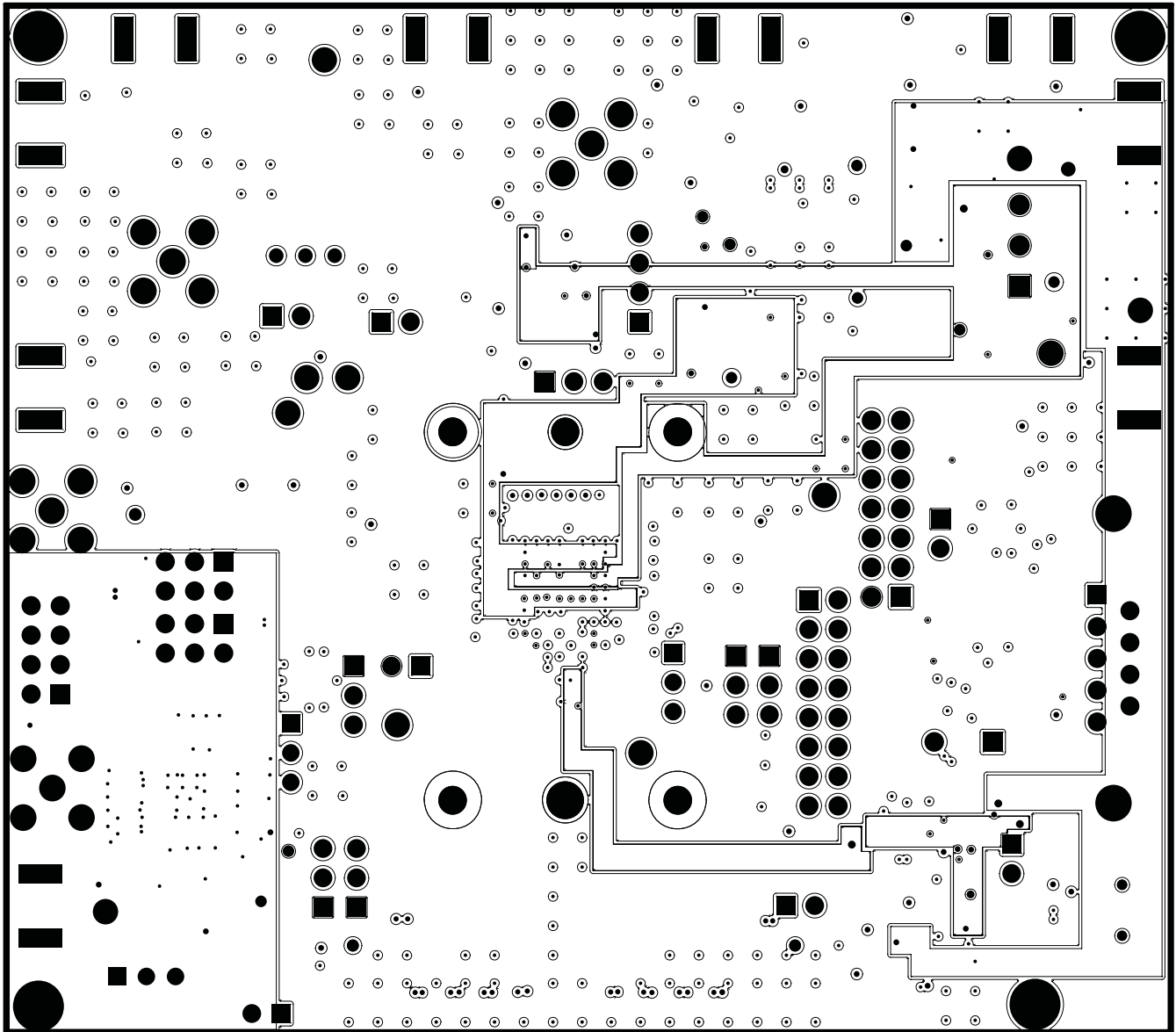

Figure 13. Inner Layer 3, Power

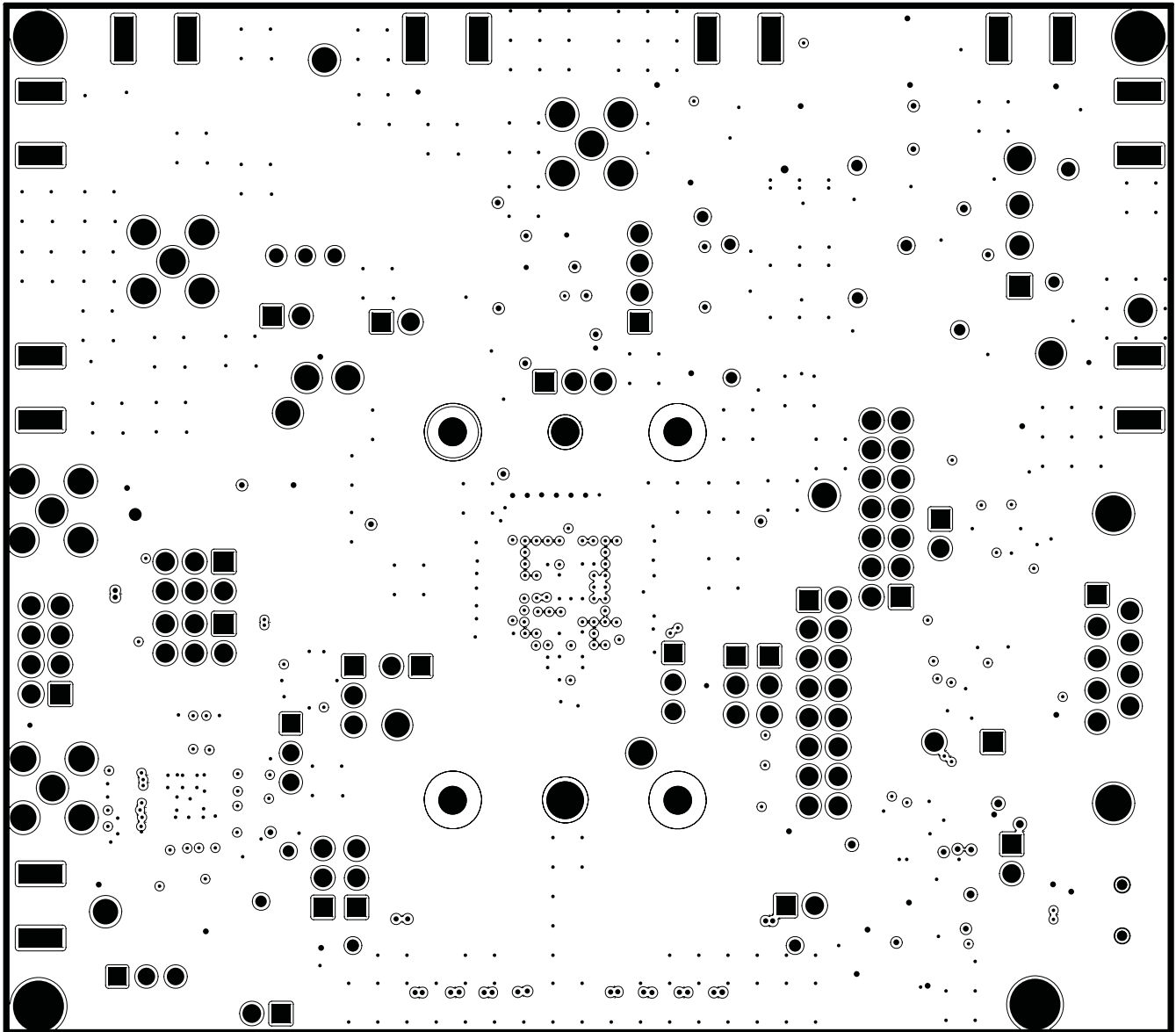

Figure 14. Inner Layer 4, Ground

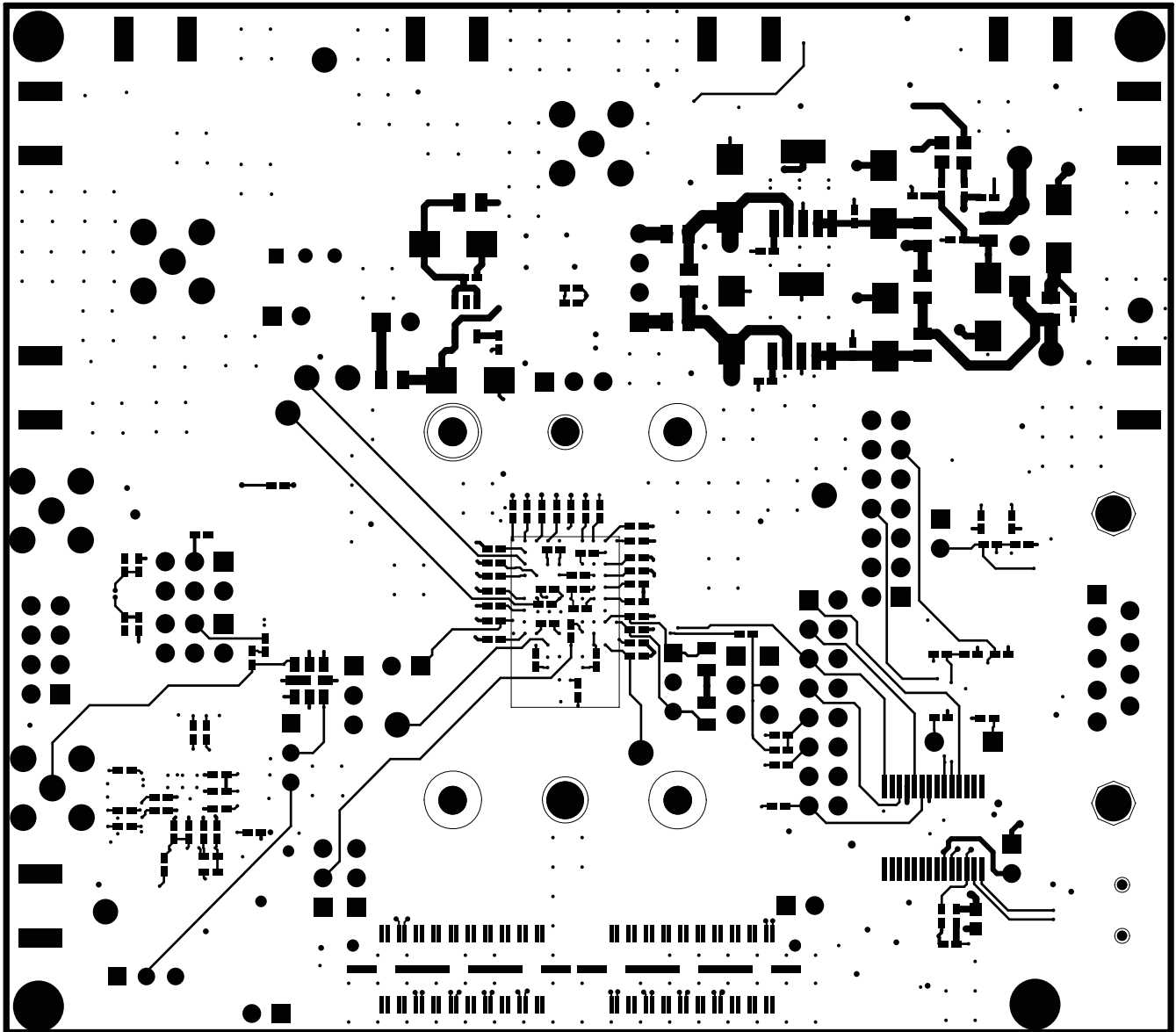

Figure 15. Bottom Layer, Signal

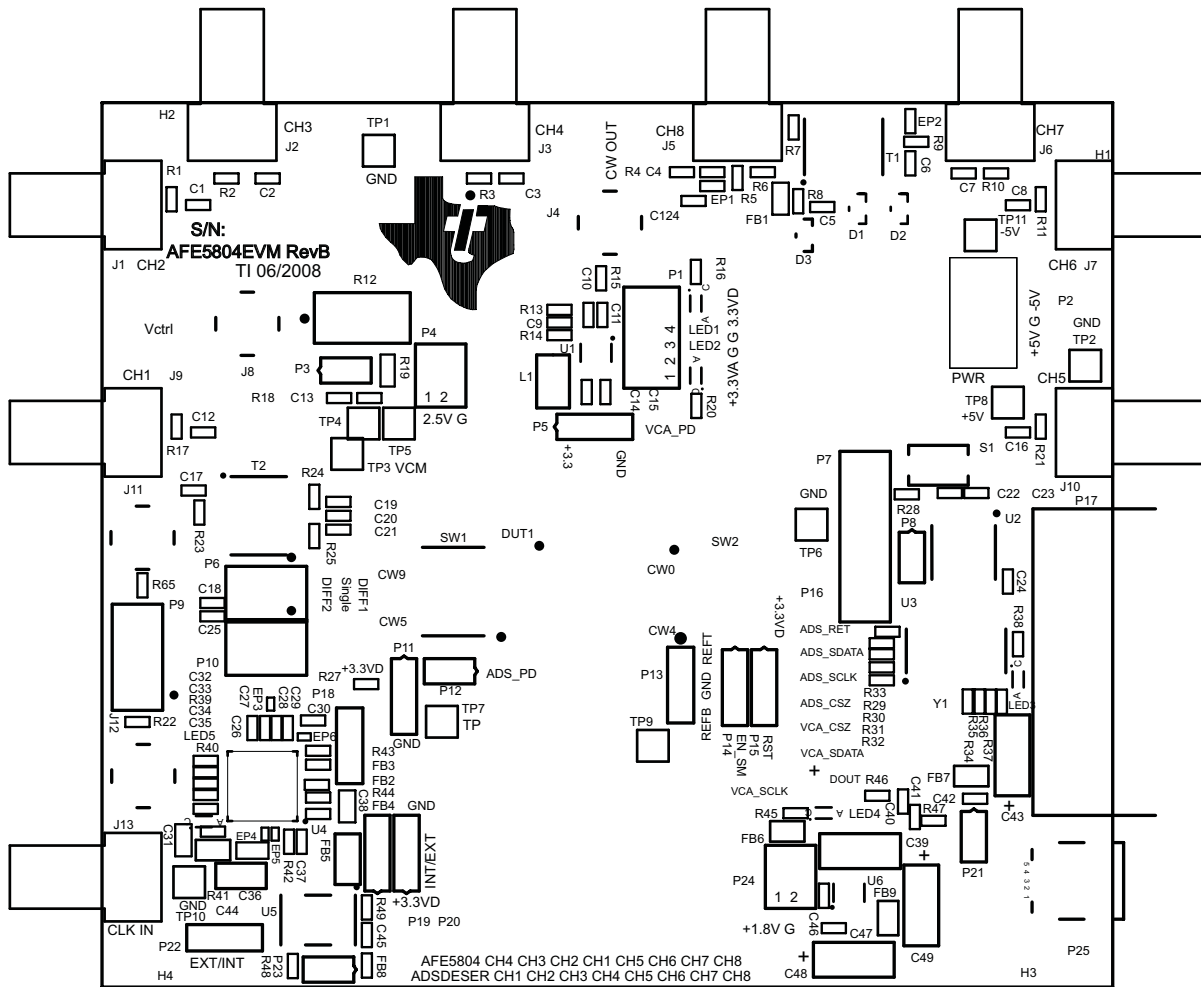

Figure 16. Top Silk Screen Layer

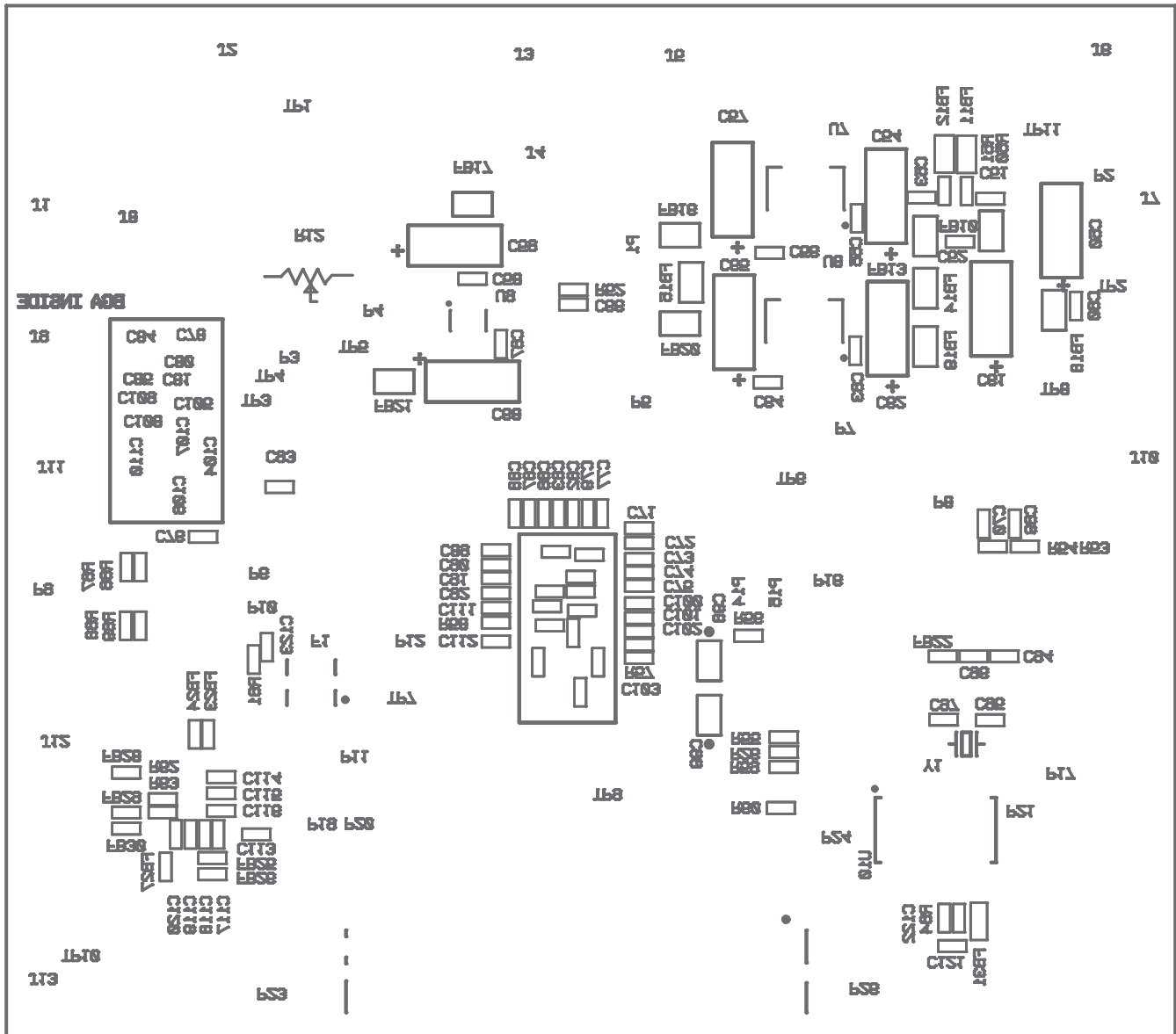

Figure 17. Bottom Silk Screen Layer

4.3 Bill of Materials

Table 3. Bill of Materials

Item	MFG	MFG Part Number	RefDes	Value or Function
1	TI	MSP430F1232IPW	U3	MIXED SIGNAL MICROCONTROLLER
2	KEMET	C0402C103K3RAC	C9	CAPACITOR,SMT,0402,CER,0.01μF,25V,10%,X7R
3	KEMET	C0402C104K8PAC	C1, C2, C3, C4, C5, C6, C7, C8, C10, C11, C12, C13, C14, C15, C16, C17, C18, C19, C20, C21, C22, C23, C24, C25, C26, C27, C28, C29, C30, C32, C33, C34, C35, C40, C41, C42, C45, C46, C47, C51, C52, C53, C55, C56, C58, C60, C63, C64, C67, C69, C70, C71, C72, C73, C74, C75, C76, C77, C78, C79, C80, C81, C82, C83, C84, C85, C86, C87, C88, C89, C90, C91, C93, C94, C96, C100, C101, C102, C103, C104, C105, C106, C107, C108, C109, C110, C111, C112, C113, C114, C115, C116, C117, C118, C119, C120, C121, C122, C123, C124	CAPACITOR,SMT,0402,CER,0.1μF,10V,10%,X5R
4	PANASONIC	ECJ-0EC1H100D	C66, C95, C97	CAPACITOR,SMT,0402,CER,10pF,50V,±0.5pF,NPO
5	MURATE	GRM155R60J225ME15D	C37, C92	CAPACITOR,SMT,0402,CERAMIC,2.2μF,6.3V,20%,X5R
6	PANASONIC	ECJ-1VB0J475K	C36	CAPACITOR,SMT,0603,CER,4.7μF,6.3V,10%,X5R
7	TAIYO YUDEN	JMK107BJ106MA-T	C31, C38	CAPACITOR,SMT,0603,CER,10μF,6.3V,20%,X5R
8	MURATA	GRM31CR60J476ME19B	C44	CAPACITOR,SMT,CER,1206,47μF,6.3V,20%,X5R
9	AVX	TACR475M020R	C98, C99	CAP,SMT,TAN,0805,4.7μF,20V,20%,R-CASE
10	AVX	TPSC226K016R0375	C39, C43, C48, C49, C50, C54, C57, C59, C61, C62, C65, C68	10%, 16V, 22μF
11	SAMTEC	SMA-J-P-X-ST-EM1	J1, J2, J3, J5, J6, J7, J9, J10, J13	SMA JACK EDGE MOUNT,062PCB,BRASS/GOLD,STRAIGHT,50 Ω
12	SAMTEC	SMA-J-P-H-ST-TH1	J4, J8, J11, J12	SMA COAX STRAIGHT PCB JACK,SMT,175TL,50 Ω,GOLD
13	TYCO ELECTRONICS	745781-4	P17	DSUB, 9 PIN, R/A FEM
14	ADVANCED CONNECTER	MNE20-5K5P10	P25	MINI-AB USB OTG RECEPTACLE R/A SMT TYPE
15	USCC	HC-18/U-4.1943M	Y1	4.194300 MHz
16	EPSON TOYOCOM	HF-372A(UNINSTALLED)	F1	CRYSTAL FILTER UNINSTALLED
17	TI	N/A	U4	(UNINSTALLED)
18	Not Installed	PAD0201(UN)	EP4, EP6	(Uninstalled Part) EMPTY PAD,SMT,0201
19	Not Installed	PAD0402(UN)	EP1, EP2	(Uninstalled Part) EMPTY PAD,SMT,0402
20	MURATA	BLM15BD102SN1D	FB2, FB3, FB4, FB8, FB22, FB23, FB24, FB25, FB26, FB27, FB28, FB29, FB30	FERRITE BEAD,SMT,0402,1 kΩ,200mA
21	MURATA	BLM18EG601SN1D	FB31	FERRITE BEAD,SMT,0603,600 Ω at 100MHz,25%,500mA
22	STEWART	HI0805R800R-00	FB6, FB7, FB9, FB10, FB13, FB14, FB15, FB16, FB17, FB18, FB19, FB20, FB21	FERRITE,SMT,0805,80 Ω at 100MHz
23	STEWART	LI1206H151R-00	FB5	FERRITE,SMT,1206,150 Ω at 100MHz,0.8A
24	MOLEX	39357-0003	P2	HEADER, THRU, POWER, 3P,3.5MM, EUROSTYLE
25	SAMTEC	QTH-040-01-L-D-DP-A	P26	HEADER,SMT,80P,0.5mm,FEM,DIFF PAIR,RECEPTACLE,168H
26	SAMTEC	SSQ-104-02-F-D	P9	HEADER,THU,8P,2x4,100LS,FEM,VERT,194TL
27	SAMTEC	TSW-103-08-G-D	P6, P10	HEADER,THU,6P,2x3,MALE,DUAL ROW,100LS,200TL
28	SAMTEC	TSW-107-07-G-D	P7	HEADER,THU,14P,2x7,MALE,DUAL ROW,100LS,100TL
29	SAMTEC	TSW-108-07-G-D	P16	HEADER,THU,16P,2x8,MALE,DUAL ROW,100LS,100TL(UNINSTALLED)
30	TYCO ELECTRONICS	103321-2	P3, P8, P12, P21, P23	HEADER W/SHUNT,2P,100LS

Table 3. Bill of Materials (continued)

Item	MFG	MFG Part Number	RefDes	Value or Function
31	MOLEX	22-23-2021-P	P4, P24	MALE,2PIN,.100CC W/ FRICTION LOCK
32	MILL-MAX	350-10-103-00-006	P13, P18, P22	HEADER,THU,MAL,0.1LS,3P,1x3,284H,110TL
33	MOLEX	22-23-2041	P1	4P, VERT, FRICTION LOCK
34	TYCO ELECTRONICS	4-103239-0x3	P5, P11, P14, P15, P19, P20	HEADER,THU,MAL,0.1LS,3P,1x3
35	TI	AFE5804	DUT1	AFE5804 8-CH ULTRASOUND ANALOG FRONT END
36	MAXIM	MAX3221CAE	U2	RS-232 TRANSCEIVERS
37	MOTOROLA	MMBD7000LT1	D1, D2	DUAL SWITCHING DIODE
38	PHILIPS	BAP50-04	D3	PIN DIODE SOT 23 SINGLE JUNCTION
39	TI	TPS79633DCQR	U7(UNINSTALLED), U8	ULTRALOW-NOISE HI PSRR FAST RF 1-A LDO LINEAR REGULATOR,3.3V
40	TI/BURR-BROWN	OPA820IDBV	U1	UNITY-GAIN STABLE LOW NOISE VOLTAGE FEEDBACK OPAMP
41	TI	TPS79318DBV	U6	1.8V,ULTRALOW-NOISE HI PSRR FAST RF 200mA LDO LINEAR REGULATOR
42	TI	TPS79325DBV	U9	2.5V,ULTRALOW-NOISE HI PSRR FAST RF 200mA LDO LINEAR REGULATOR
43	FUTURE TECHNOLOGY DEVICE INT.	FT245RL	U10	USB FIFO IC INCORPORATE FTDICHIP-ID SECURITY DONGLE
44	PANASONIC	ELJFA221J	L1	220μH, 5%
45	TAIYO-YUDEN	LK 1608 330M	FB1, FB11, FB12	INDUCTOR,SMT0603,33.0μH,20%
46	PANASONIC	LNJ308G8PRA	LED1, LED2, LED3, LED5	LED,SMT,0603,PURE GREEN,2.03V
47	PANASONIC	LNJ808R8ERA	LED4	LED,SMT,0603,ORANGE,1.8V
48	ECS	ECS-3953M-400-BN	U5	OSC,SMT,3.3V,50ppm,-40~85C,5nS,40.000 MHz
49	PANASONIC	ERJ-2GE0R00X	R26, R27, R40, R42, R44, R48, R53, R55, R56, R63, R65	RESISTOR/JUMPER,SMT,0402,0 Ω,5%,1/16W
50	PANASONIC	ERJ-2GEJ0000(UN)	R6, R7, R29, R30, R31, R32, R34, R35, R36, R37, R39, R43, R46, R49, R54, R59, R60, R62, R64	UNINSTALLED PART
51	PANASONIC	ERJ-2GEJ131	R66, R69	RESISTOR, SMT, 0402, 130 Ω, ±1%, 1/16W
52	PANASONIC	ERJ-2GEJ49R9(UN)	R4, R9, R22	UNINSTALLED PART
53	PANASONIC	ERJ-2RKF5602X	R57	RESISTOR, SMT, 0402, 56K Ω, 1%, 1/16W
54	PANASONIC	ERJ-2GEJ820	R67, R68	RESISTOR, SMT, 0402, ±5%,82
55	PANASONIC	ERJ-2RKF1000X	R24, R25	RESISTOR,SMT,0402,100 Ω,1%,1/16W
56	PANASONIC	ERJ-2RKF1001X	R13, R14, R18, R47	RESISTOR,SMT,0402,1.00K,1%,1/16W
57	PANASONIC	ERJ-2RKF1002X	R33, R58	RESISTOR,SMT,0402,10.0K,1%,1/16W
58	PANASONIC	ERJ-2RKF2000X	R52	RES,SMT,0402,200 Ω,1%,1/16W
59	PANASONIC	ERJ-2RKF3320X	R16, R20, R38, R45	RES,SMT,0402,332 Ω,1%,1/16W
60	PANASONIC	ERJ-2RKF4020X	R8	RES,SMT,0402,402 Ω,1%,1/16W
61	PANASONIC	ERJ-2RKF4992X	R28	RESISTOR,SMT,0402,49.9K,1%,1/16W
62	PANASONIC	ERJ-2RKF49R9X	R1, R2, R3, R5, R10, R11, R15, R17, R21, R23, R61	RESISTOR,SMT,0402,49.9 Ω,1%,1/16W
63	PANASONIC	ERJ-2RKF7500X	R50, R51	RES,SMT,0402,750 Ω,1%,1/16W
64	VISHAY	CRCW06031742F	R19	RES,SMT,0603,17.4K Ω, 1%
65	PANASONIC	ERJ-6RQF5R1V	R41	SMT,RES,0805,1/8W, 1%, 5.1 Ω
66	PANASONIC	ERJ-1GE0R00C	EP3, EP5	RESISTOR,SMT,0201,THICK FILM,0 Ω,5%,0 Ω JUMPER,1/20W
67	C&K	TD06H0SK1	SW1, SW2	DIP SWITCH,SMT,6POS,SPST,MINIATURE
68	PANASONIC	EVQPE104K	S1	SQUARE LIGHT TOUCH SWITCH,SMT,SPST
69	KEYSTONE ELECTRONICS	5005	TP8	TESTPOINT,THU,COMPACT,0.125LS,130TL, RED
70	KEYSTONE ELECTRONICS	5006	TP1, TP2, TP5, TP6, TP10	TESTPOINT,THU,COMPACT,0.125LS,130TL, BLACK
71	KEYSTONE ELECTRONICS	5006(UN)	TP3, TP4, TP7, TP9	UNINSTALLED PART (TEST POINT)

Table 3. Bill of Materials (continued)

Item	MFG	MFG Part Number	RefDes	Value or Function
72	KEYSTONE ELECTRONICS	5007	TP11	TESTPOINT,THU,COMPACT,0.125LS,130TL, WHITE
73	MINI-CIRCUITS	ADTI-6T	T1(UNINSTALLED), T2	RF TRANSFORMER WIDEBAND, 0.03-125 MHz
74	BOURNS	3296W-1-103	R12	TRIMPOT,THU,10K,10%,0.5W,100ppm,25T
75	AMP	531220-2	P3, P8, P12, P21, P23	SHUNTS
76	KEYSTONE ELECTRONICS	1892	H1,H2,H3,H4; (H3 and H4 are UNINSTALLED)	STANDOFF HEX 4-40 THR 0.375"L ALUM
77	BUILDING FASTENERS	PMS 440 0025 SL	H1,H2,H3,H4; (H3 and H4 are UNINSTALLED)	SCREW MACHINE SLOTTED 4-40x1/4

5 Typical Performance

This section provides some typical performance characteristics of the AFE5804EVM to assist users in verifying their setup.

After analysis of the data file acquired by a logic analyzer, the SNR of the AFE5804 should be better than 59 dB when the PGA is set to 30 dB, the filter is set to 12.5 MHz, the mode is set to TGC1, and Vcntl is set as 1 V. A typical performance plot of the AFE5804 is shown in [Figure 18](#).

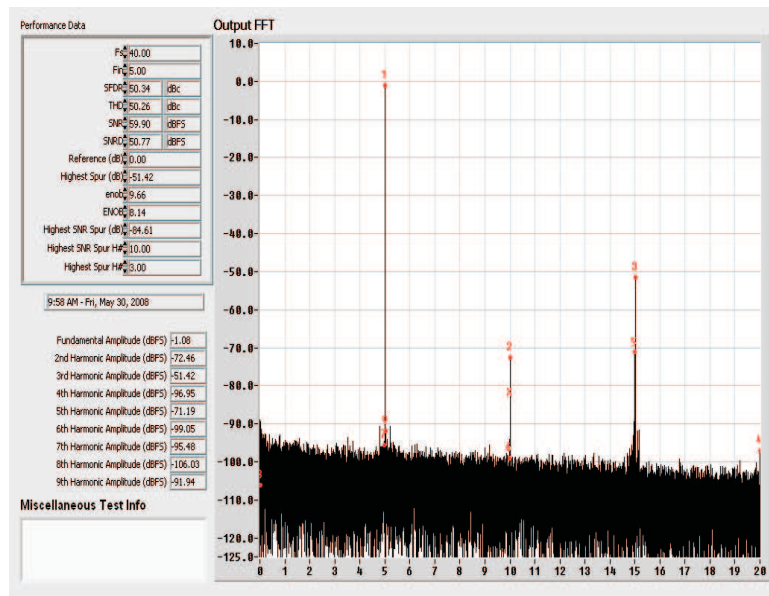

(a) PGA = 30 dB, Vcntl = 1 V, Vin = 11 mVpp

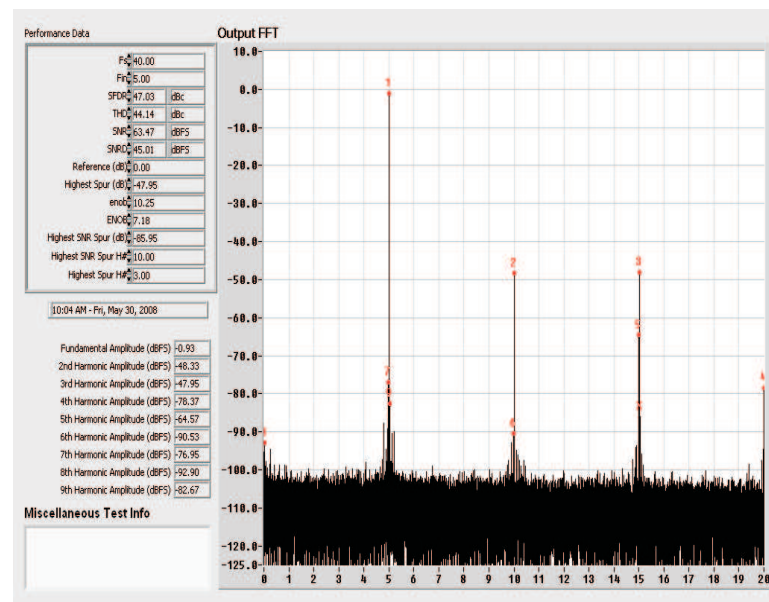

(b) PGA = 30 dB, Vcntl = 0.34 V, Vin = 290 mVpp

Figure 18. Typical Performances of AFE5804

As [Figure 18](#) shows, the SNR degrades as the gain increases; the HD degrades as the input signal increases.

Appendix A TSW1100 for Evaluating AFE5804/5

This appendix describes the use of TSW1100 software to analyze data files acquired by logic analyzers.

As previously mentioned, coherent sampling is recommended when HP8644s are used. The calculation of coherent sampling rate and signal frequency can be found in the TSW1100 user's manual ([SLAU163](#)).

Users can set the calculated frequencies for signal generators; acquire ADC data through a logic analyzer; and save the data as a text file. A typical data file captured by a logic analyzer must be modified to the following format (i.e., containing only one column):

```

1981
1615
1292
1046
895
852
927
1113
1394
1737
2110
2477
2798
3044
3196
3237
3162
2978
.
.
.
.

```

The AFE5804/5 performance analysis can be done as follows:

- First, add some header information to the modified logic analyzer data file as follows. Example files are included in the TSW1100 software package. Modify time, sampling rate, and frequency-in based on your setup:

```

TSW1000
2/12/2007 12:38
Bits =12
Sampling Rate =40000000.000
Frequency in =1998291.0156
2s complement =No
Data Format =Decimal
Raw Captured Data:
1981
1615
1292
1046
895
852
927
1113
1394
1737
2110
2477
2798

```

3044
3196
3237
3162
2978
2702
2358

- Then, select TSW1000 as the TI chip as shown in [Figure A-1](#).

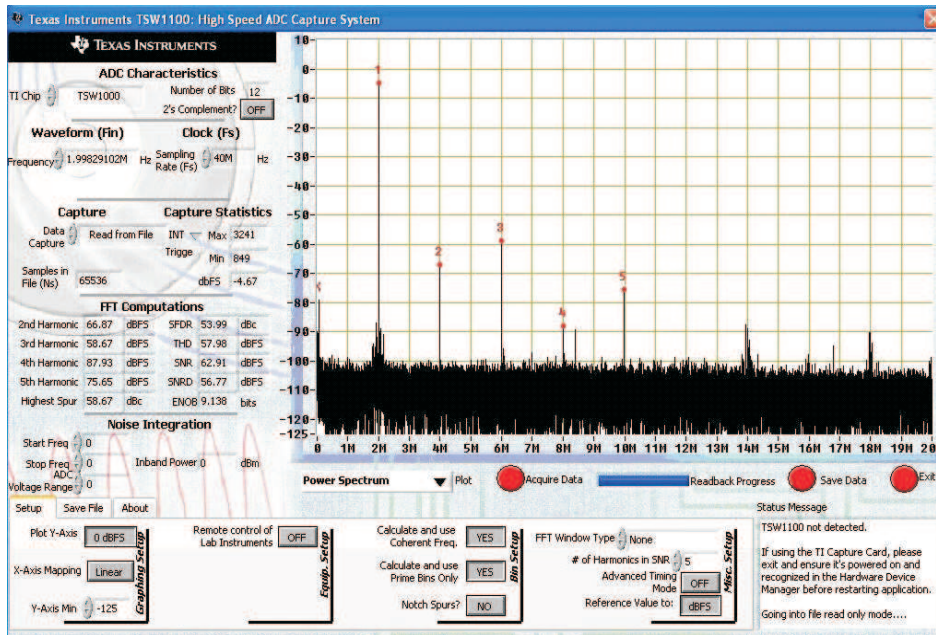
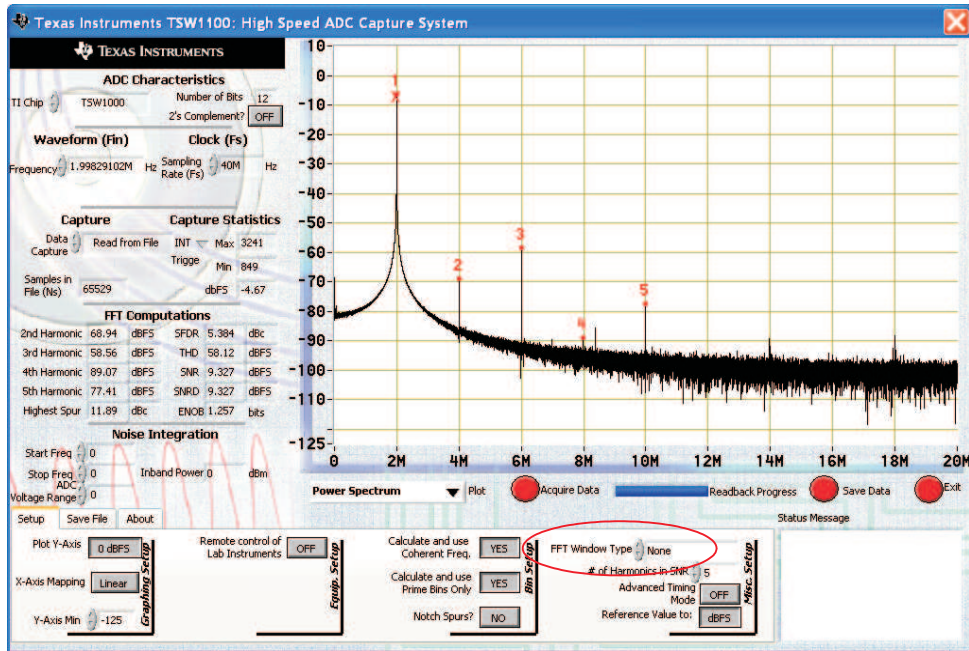

Figure A-1. TSW1100 Interface

- Finally, click the *Acquire Data* button, select the text file with header information, and see the analysis results.

TSW1100 also supports analysis of noncoherent sampled data. However, some artifacts may be noticed during analysis. The appropriate FFT window must be applied to the data.

Users must first follow the preceding steps to get the nonwindowed analysis results shown in [Figure A-2\(a\)](#). Then, after the appropriate FFT window is applied, the correct analysis results are obtained as shown in [Figure A-2\(b\)](#). Note that some DC artifacts can be seen in [Figure A-1\(b\)](#).



(a) No window applied

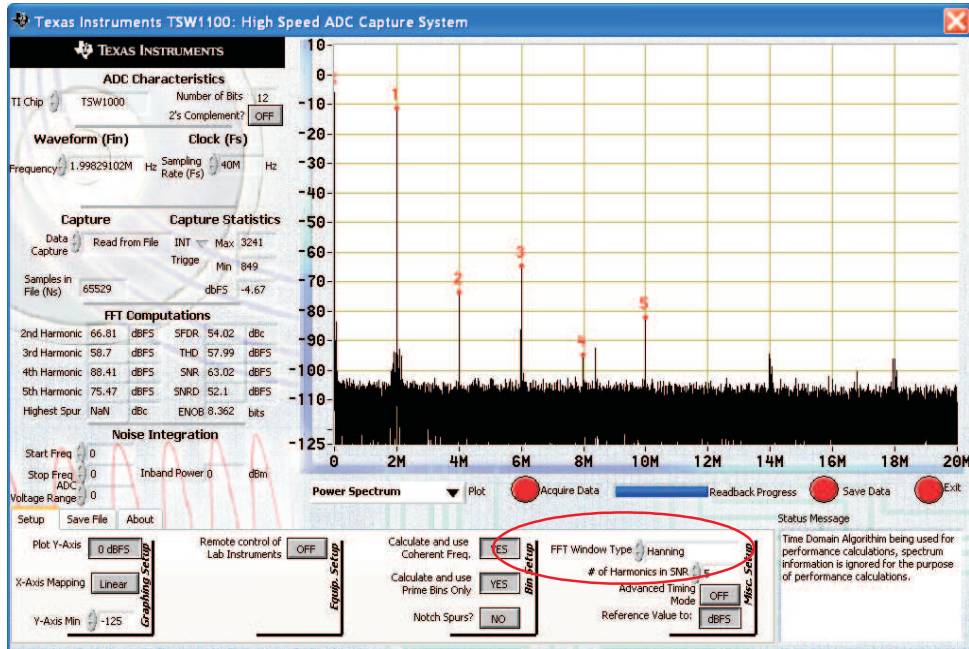

(b) Hanning window applied. Note the DC artifact that is visible.

Figure A-2. Analysis of Noncoherent Sampled Data

ADS INPUT CLOCK

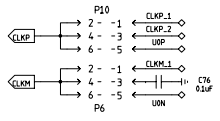
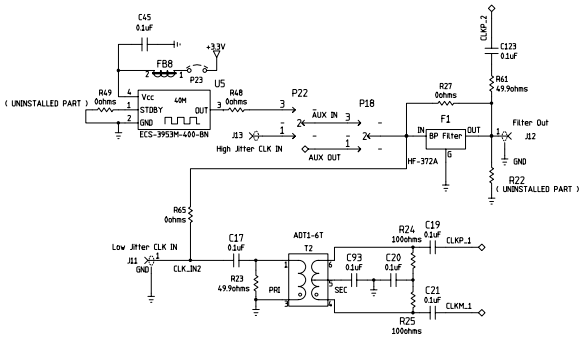
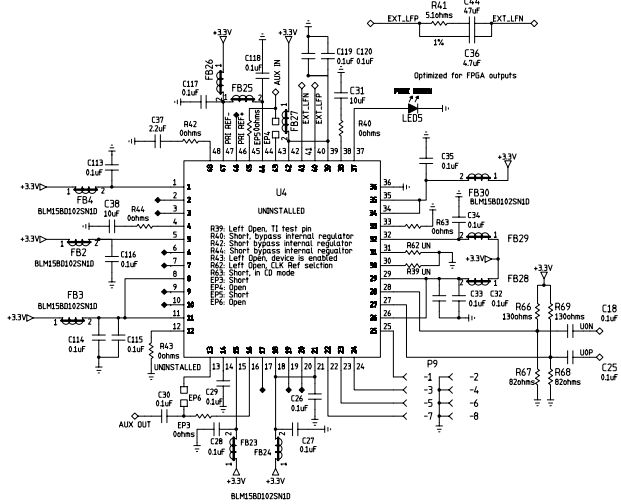

POWER MANAGEMENT

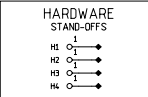
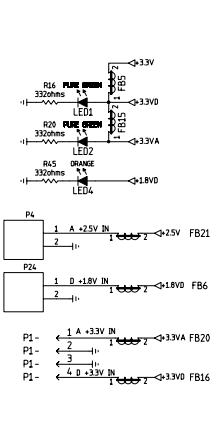
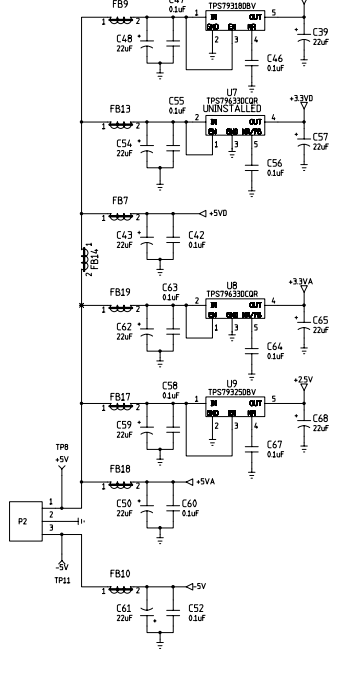

USB SPI CONTROLLER

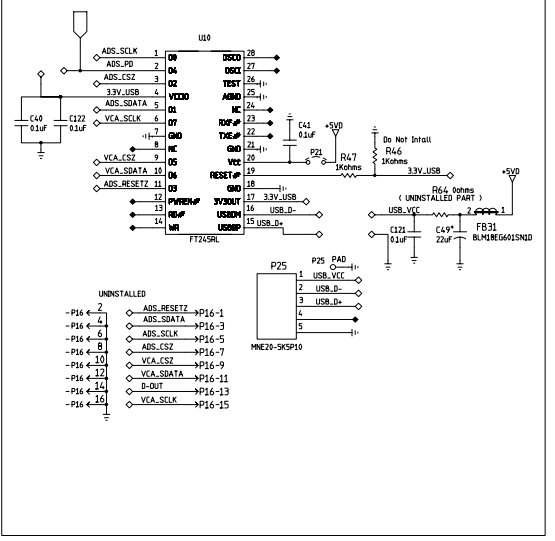

RS232 SPI CONTROLLER

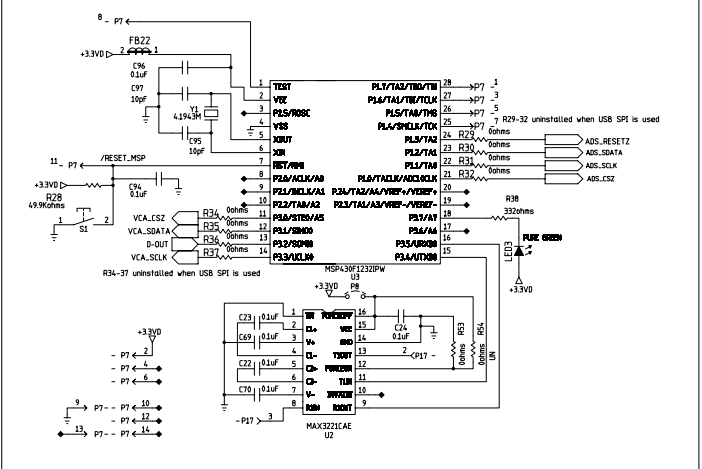

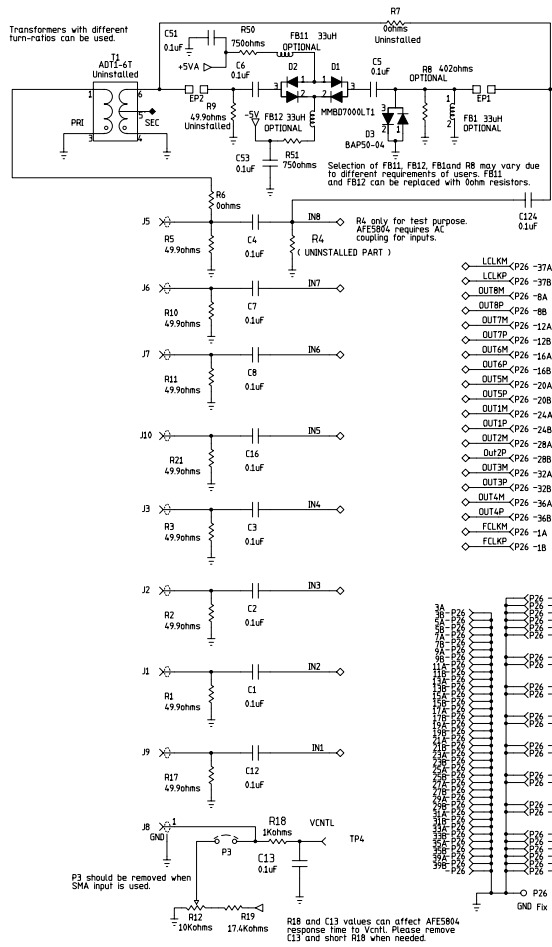

Signal Input/Output

- ◊ LCLKM <P26 -37A
- ◊ LCLKP <P26 -37B
- ◊ OUT8M <P26 -8A
- ◊ OUT8P <P26 -8B
- ◊ OUT7M <P26 -12A
- ◊ OUT7P <P26 -12B
- ◊ OUT6M <P26 -16A
- ◊ OUT6P <P26 -16B
- ◊ OUT5M <P26 -20A
- ◊ OUT5P <P26 -20B
- ◊ OUT4M <P26 -24A
- ◊ OUT4P <P26 -24B
- ◊ OUT3M <P26 -28A
- ◊ OUT3P <P26 -28B
- ◊ OUT2M <P26 -32A
- ◊ OUT2P <P26 -32B
- ◊ OUT1M <P26 -36A
- ◊ OUT1P <P26 -36B
- ◊ FCLKM <P26 -1A
- ◊ FCLKP <P26 -1B

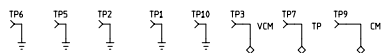
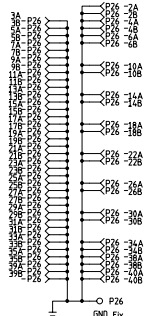

DC and GND Test Points

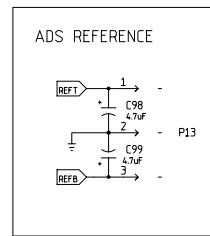
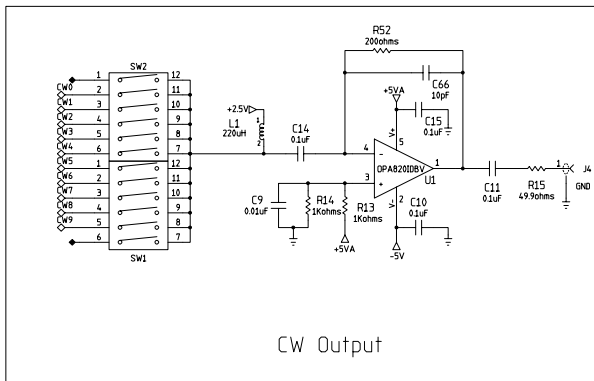
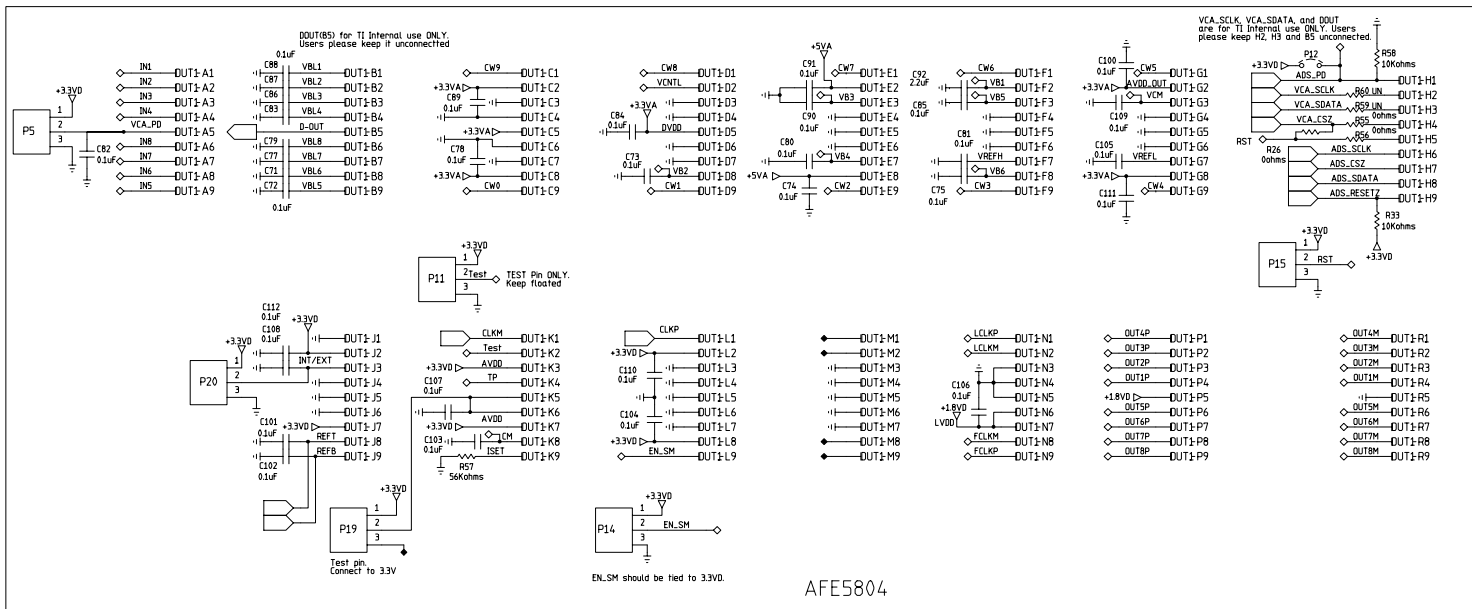

EVALUATION BOARD/KIT IMPORTANT NOTICE

Texas Instruments (TI) provides the enclosed product(s) under the following conditions:

This evaluation board/kit is intended for use for **ENGINEERING DEVELOPMENT, DEMONSTRATION, OR EVALUATION PURPOSES ONLY** and is not considered by TI to be a finished end-product fit for general consumer use. Persons handling the product(s) must have electronics training and observe good engineering practice standards. As such, the goods being provided are not intended to be complete in terms of required design-, marketing-, and/or manufacturing-related protective considerations, including product safety and environmental measures typically found in end products that incorporate such semiconductor components or circuit boards. This evaluation board/kit does not fall within the scope of the European Union directives regarding electromagnetic compatibility, restricted substances (RoHS), recycling (WEEE), FCC, CE or UL, and therefore may not meet the technical requirements of these directives or other related directives.

Should this evaluation board/kit not meet the specifications indicated in the User's Guide, the board/kit may be returned within 30 days from the date of delivery for a full refund. **THE FOREGOING WARRANTY IS THE EXCLUSIVE WARRANTY MADE BY SELLER TO BUYER AND IS IN LIEU OF ALL OTHER WARRANTIES, EXPRESSED, IMPLIED, OR STATUTORY, INCLUDING ANY WARRANTY OF MERCHANTABILITY OR FITNESS FOR ANY PARTICULAR PURPOSE.**

The user assumes all responsibility and liability for proper and safe handling of the goods. Further, the user indemnifies TI from all claims arising from the handling or use of the goods. Due to the open construction of the product, it is the user's responsibility to take any and all appropriate precautions with regard to electrostatic discharge.

EXCEPT TO THE EXTENT OF THE INDEMNITY SET FORTH ABOVE, NEITHER PARTY SHALL BE LIABLE TO THE OTHER FOR ANY INDIRECT, SPECIAL, INCIDENTAL, OR CONSEQUENTIAL DAMAGES.

TI currently deals with a variety of customers for products, and therefore our arrangement with the user **is not exclusive.**

TI assumes **no liability for applications assistance, customer product design, software performance, or infringement of patents or services described herein.**

Please read the User's Guide and, specifically, the Warnings and Restrictions notice in the User's Guide prior to handling the product. This notice contains important safety information about temperatures and voltages. For additional information on TI's environmental and/or safety programs, please contact the TI application engineer or visit www.ti.com/esh.

No license is granted under any patent right or other intellectual property right of TI covering or relating to any machine, process, or combination in which such TI products or services might be or are used.

FCC Warning

This evaluation board/kit is intended for use for **ENGINEERING DEVELOPMENT, DEMONSTRATION, OR EVALUATION PURPOSES ONLY** and is not considered by TI to be a finished end-product fit for general consumer use. It generates, uses, and can radiate radio frequency energy and has not been tested for compliance with the limits of computing devices pursuant to part 15 of FCC rules, which are designed to provide reasonable protection against radio frequency interference. Operation of this equipment in other environments may cause interference with radio communications, in which case the user at his own expense will be required to take whatever measures may be required to correct this interference.

EVM WARNINGS AND RESTRICTIONS

It is important to operate this EVM within the input voltage range of ± 4.75 V to ± 5.25 V and the output voltage range of -5 V to +5 V.

Exceeding the specified input range may cause unexpected operation and/or irreversible damage to the EVM. If there are questions concerning the input range, please contact a TI field representative prior to connecting the input power.

Applying loads outside of the specified output range may result in unintended operation and/or possible permanent damage to the EVM. Please consult the EVM User's Guide prior to connecting any load to the EVM output. If there is uncertainty as to the load specification, please contact a TI field representative.

During normal operation, some circuit components may have case temperatures greater than 85°C. The EVM is designed to operate properly with certain components above 0°C as long as the input and output ranges are maintained. These components include but are not limited to linear regulators, switching transistors, pass transistors, and current sense resistors. These types of devices can be identified using the EVM schematic located in the EVM User's Guide. When placing measurement probes near these devices during operation, please be aware that these devices may be very warm to the touch.

Mailing Address: Texas Instruments, Post Office Box 655303, Dallas, Texas 75265
Copyright © 2008, Texas Instruments Incorporated

IMPORTANT NOTICE

Texas Instruments Incorporated and its subsidiaries (TI) reserve the right to make corrections, modifications, enhancements, improvements, and other changes to its products and services at any time and to discontinue any product or service without notice. Customers should obtain the latest relevant information before placing orders and should verify that such information is current and complete. All products are sold subject to TI's terms and conditions of sale supplied at the time of order acknowledgment.

TI warrants performance of its hardware products to the specifications applicable at the time of sale in accordance with TI's standard warranty. Testing and other quality control techniques are used to the extent TI deems necessary to support this warranty. Except where mandated by government requirements, testing of all parameters of each product is not necessarily performed.

TI assumes no liability for applications assistance or customer product design. Customers are responsible for their products and applications using TI components. To minimize the risks associated with customer products and applications, customers should provide adequate design and operating safeguards.

TI does not warrant or represent that any license, either express or implied, is granted under any TI patent right, copyright, mask work right, or other TI intellectual property right relating to any combination, machine, or process in which TI products or services are used. Information published by TI regarding third-party products or services does not constitute a license from TI to use such products or services or a warranty or endorsement thereof. Use of such information may require a license from a third party under the patents or other intellectual property of the third party, or a license from TI under the patents or other intellectual property of TI.

Reproduction of TI information in TI data books or data sheets is permissible only if reproduction is without alteration and is accompanied by all associated warranties, conditions, limitations, and notices. Reproduction of this information with alteration is an unfair and deceptive business practice. TI is not responsible or liable for such altered documentation. Information of third parties may be subject to additional restrictions.

Resale of TI products or services with statements different from or beyond the parameters stated by TI for that product or service voids all express and any implied warranties for the associated TI product or service and is an unfair and deceptive business practice. TI is not responsible or liable for any such statements.

TI products are not authorized for use in safety-critical applications (such as life support) where a failure of the TI product would reasonably be expected to cause severe personal injury or death, unless officers of the parties have executed an agreement specifically governing such use. Buyers represent that they have all necessary expertise in the safety and regulatory ramifications of their applications, and acknowledge and agree that they are solely responsible for all legal, regulatory and safety-related requirements concerning their products and any use of TI products in such safety-critical applications, notwithstanding any applications-related information or support that may be provided by TI. Further, Buyers must fully indemnify TI and its representatives against any damages arising out of the use of TI products in such safety-critical applications.

TI products are neither designed nor intended for use in military/aerospace applications or environments unless the TI products are specifically designated by TI as military-grade or "enhanced plastic." Only products designated by TI as military-grade meet military specifications. Buyers acknowledge and agree that any such use of TI products which TI has not designated as military-grade is solely at the Buyer's risk, and that they are solely responsible for compliance with all legal and regulatory requirements in connection with such use.

TI products are neither designed nor intended for use in automotive applications or environments unless the specific TI products are designated by TI as compliant with ISO/TS 16949 requirements. Buyers acknowledge and agree that, if they use any non-designated products in automotive applications, TI will not be responsible for any failure to meet such requirements.

Following are URLs where you can obtain information on other Texas Instruments products and application solutions:

Products

Amplifiers	amplifier.ti.com
Data Converters	dataconverter.ti.com
DSP	dsp.ti.com
Clocks and Timers	www.ti.com/clocks
Interface	interface.ti.com
Logic	logic.ti.com
Power Mgmt	power.ti.com
Microcontrollers	microcontroller.ti.com
RFID	www.ti-rfid.com
RF/IF and ZigBee® Solutions	www.ti.com/lprf

Applications

Audio	www.ti.com/audio
Automotive	www.ti.com/automotive
Broadband	www.ti.com/broadband
Digital Control	www.ti.com/digitalcontrol
Medical	www.ti.com/medical
Military	www.ti.com/military
Optical Networking	www.ti.com/opticalnetwork
Security	www.ti.com/security
Telephony	www.ti.com/telephony
Video & Imaging	www.ti.com/video
Wireless	www.ti.com/wireless

Mailing Address: Texas Instruments, Post Office Box 655303, Dallas, Texas 75265
Copyright © 2008, Texas Instruments Incorporated



Компания «ЭлектроПласт» предлагает заключение долгосрочных отношений при поставках импортных электронных компонентов на взаимовыгодных условиях!

Наши преимущества:

- Оперативные поставки широкого спектра электронных компонентов отечественного и импортного производства напрямую от производителей и с крупнейших мировых складов;
- Поставка более 17-ти миллионов наименований электронных компонентов;
- Поставка сложных, дефицитных, либо снятых с производства позиций;
- Оперативные сроки поставки под заказ (от 5 рабочих дней);
- Экспресс доставка в любую точку России;
- Техническая поддержка проекта, помощь в подборе аналогов, поставка прототипов;
- Система менеджмента качества сертифицирована по Международному стандарту ISO 9001;
- Лицензия ФСБ на осуществление работ с использованием сведений, составляющих государственную тайну;
- Поставка специализированных компонентов (Xilinx, Altera, Analog Devices, Intersil, Interpoint, Microsemi, Aeroflex, Peregrine, Syfer, Eurofarad, Texas Instrument, Miteq, Cobham, E2V, MA-COM, Hittite, Mini-Circuits, General Dynamics и др.);

Помимо этого, одним из направлений компании «ЭлектроПласт» является направление «Источники питания». Мы предлагаем Вам помощь Конструкторского отдела:

- Подбор оптимального решения, техническое обоснование при выборе компонента;
- Подбор аналогов;
- Консультации по применению компонента;
- Поставка образцов и прототипов;
- Техническая поддержка проекта;
- Защита от снятия компонента с производства.



Как с нами связаться

Телефон: 8 (812) 309 58 32 (многоканальный)

Факс: 8 (812) 320-02-42

Электронная почта: org@eplast1.ru

Адрес: 198099, г. Санкт-Петербург, ул. Калинина, дом 2, корпус 4, литера А.