

## ECONOMONITOR™ – 3-Pin System Supervisor with Power Supply Monitor and Watchdog

### Features:

- Incorporates the Functionality of the Industry Standard TC1232 (Processor Monitor, Watchdog and Manual Override Reset Controller) into a Small, Lower Cost Package
- Guards Against Unstable Processor Operation Resulting from Power “Brown-Out”
- Automatically Halts and Restarts an Out-of-Control Microprocessor
- Output can be Wire-ORed, or Hooked to Manual Reset Push-button Switch
- Space-Saving 3-Pin TO-92 or SOT-223 Package

### Applications:

- All Microprocessor-Based Systems
- Battery Powered Computers and Controllers
- Automotive Systems
- Intelligent Instruments
- Critical Processor Monitoring
- Embedded Controllers

### Device Selection Table

Part Number	Package	Temp. Range
TC32MCDB	SOT-223	0°C to +70°C
TC32MCZB	TO-92	0°C to +70°C
TC32MEDB	SOT-223	-40°C to +85°C
TC32MEZB	TO-92	-40°C to +85°C

### Package Type

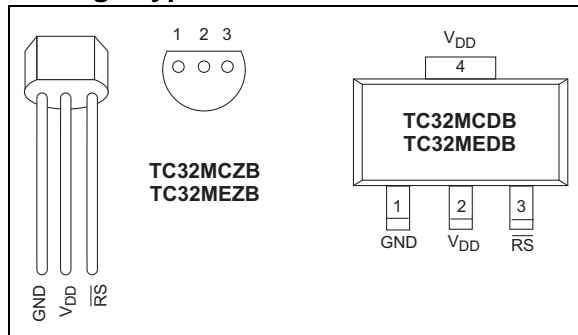

### General Description:

The TC32M is a fully-integrated processor supervisor in a 3-pin package. It provides three important functions to safeguard processor sanity: precision power on/off Reset control, Watchdog Timer and external Reset override.

On power-up, the TC32M holds the processor in the Reset state for a minimum of 500 msec after V<sub>DD</sub> is within tolerance to ensure a stable system start-up. Microprocessor sanity is monitored by the on-board Watchdog circuit. The microprocessor must provide a high-to-low level shift (through an external resistor divider) on the RS pin of the TC32M. Should the processor fail to supply this signal within the specified time-out period (typically 700 msec), an out-of-control processor is indicated and the TC32M issues a processor Reset as a result.

The output of the TC32M can be wire-ORed with a push-button switch (or electronic signal) to override the TC32M and unconditionally reset the processor. When connected to a push-button switch, the TC32M provides contact debounce.

The TC32M is packaged in a space-saving TO-92 or SOT-223 package. It provides all of the functionality of the industry standard TC1232 in a smaller, lower cost configuration.

# TC32M

## Functional Block Diagram

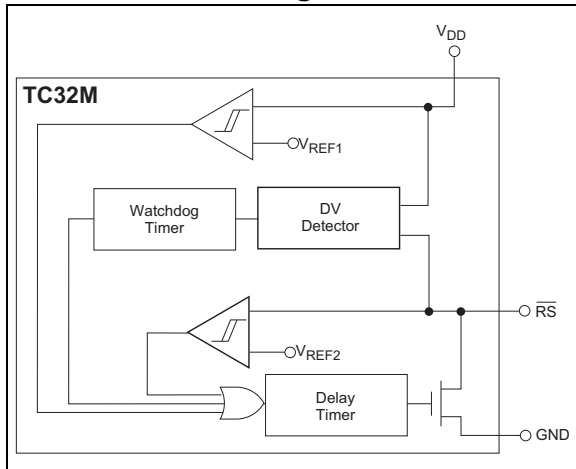

## Typical Operating Circuit

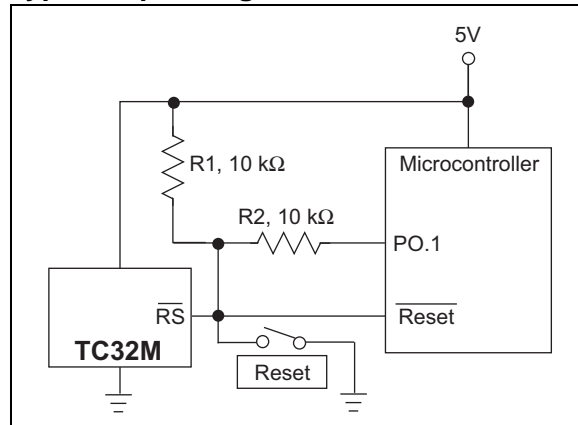

## 1.0 ELECTRICAL CHARACTERISTICS

### Absolute Maximum Ratings\*

Supply Voltage ( $V_{DD}$ to GND) .....	+6.0V
Input Voltage Any Pin..... (GND – 0.3V) to ( $V_{DD}$ +0.3V)	
Operating Temperature Range	
TC32MC Package.....	0°C to +70°C
TC32ME Package.....	-40°C to +85°C
Storage Temperature Range .....	-65°C to +150°C

\*Stresses above those listed under “Absolute Maximum Ratings” may cause permanent damage to the device. These are stress ratings only and functional operation of the device at these or any other conditions above those indicated in the operation sections of the specifications is not implied. Exposure to Absolute Maximum Rating conditions for extended periods may affect device reliability.

### TC32M ELECTRICAL SPECIFICATIONS

Recommended DC Operating Conditions: $T_A = -40^\circ\text{C}$ to $+85^\circ\text{C}$ unless otherwise noted.						
Symbol	Parameter	Min	Typ	Max	Units	Test Conditions
$V_{DD}$	Supply Voltage	4.5	—	5.5	V	
$V_{IH}$	$\overline{RS}$ Input HIGH Level for PB	2.0	—	—	V	
$V_{IL}$	$\overline{RS}$ Input LOW Level for PB	—	—	0.3	V	
DC Electrical Characteristics: $V_{DD} = 4.5\text{V}$ to $5.5\text{V}$ , $T_A = -40^\circ\text{C}$ to $+85^\circ\text{C}$ unless otherwise noted.						
Symbol	Parameter	Min	Typ	Max	Units	Test Conditions
$I_{IL}$	$\overline{RS}$ Input Leakage	-1	—	+1	mA	
$I_{OL}$	$\overline{RS}$ Output Current	2.0	10	—	mA	$V_{OL} = 0.4\text{V}$
$I_{CC}$	Operating Current	—	50	200	$\mu\text{A}$	<b>Note 1</b>
$V_{STH}$	$\overline{RS}$ Strobe HIGH Level	$(V_{DD} - 0.5\text{V})$	—	—	V	Figure 3-1
$V_{STL}$	$\overline{RS}$ Strobe LOW Level	2.00	—	$(V_{DD} - 1.5\text{V})$	V	Figure 3-1
$V_{RST}$	Reset Threshold	4.25	—	4.50	V	$V_{DD}$ Falling ( <b>Note 2</b> , Figure 3-3)
Capacitance Electrical Characteristics: $T_A = 25^\circ\text{C}$ unless otherwise noted.						
Symbol	Parameter	Min	Typ	Max	Units	Test Conditions
$C_{IN}$	Input Capacitance	—	—	5	pF	
$C_{OUT}$	Output Capacitance	—	—	7	pF	
AC Electrical Characteristics: $T_A = -40^\circ\text{C}$ to $+85^\circ\text{C}$ , $V_{DD} = 5\text{V} \pm 10\%$ , unless otherwise noted.						
Symbol	Parameter	Min	Typ	Max	Units	Test Conditions
$t_{RST}$	Reset Active Time	500	700	900	msec	Figure
$t_{ST}$	$\overline{RS}$ Strobe Pulse Width	500	—	—	nsec	Figure 3-1
$t_{TD}$	Watchdog Time-out Period	500	700	900	msec	Figure 3-1
$t_{RPD}$	$V_{DD}$ Detect to $\overline{RS}$ LOW	—	—	—	nsec	Figure 3-1

**Note 1:** No output load.

**Note 2:** All voltages referenced to ground.

# TC32M

---

## 2.0 PIN DESCRIPTIONS

The descriptions of the pins are listed in Table 2-1.

**TABLE 2-1: PIN FUNCTION TABLE**

Pin No. (SOT-223, TO-92)	Symbol	Description
1	GND	Ground.
2	V <sub>DD</sub>	The +5V power supply input.
3	RS	$\overline{\text{Reset/Strobe}}$ (Bidirectional). The open drain goes active if: V <sub>DD</sub> falls below 4.5V nominal. If pulled low by an external electronic signal or switch closure. If the Watchdog is not strobed within the minimum Watchdog Time-out period. During power-up and power-down. In the Input mode, $\overline{\text{RS}}$ connects to a voltage level shift network (typically a resistor divider to V <sub>DD</sub> .) The Watchdog Timer is reset when processor causes a voltage level $\leq V_{\text{STL}}$ to be applied to $\overline{\text{RS}}$ .
4	V <sub>DD</sub>	The +5V power supply input (SOT-223 only).

## 3.0 DETAILED DESCRIPTION

The TC32M provides three important functions to safeguard stable processor operation: precision processor monitor, Watchdog sanity timer and external override Reset control.

### 3.1 Processor Monitor

The  $\overline{RS}$  pin is immediately driven low any time  $V_{DD}$  is below the nominal threshold voltage. As a result, this pin is LOW when power is initially applied, holding the processor in its Reset state.  $\overline{RS}$  remains low for a minimum of 500 msec after  $V_{DD}$  is within tolerance to allow the power supply and processor to stabilize.

### 3.2 Watchdog Timer

The processor drives the  $\overline{RS}$  pin with an input/output (I/O) line in series with an resistor voltage divider to  $V_{DD}$ . Pulling the bottom resistor of this divider low results in an internal voltage change (*strobe*) sufficient to reset the Watchdog Timer, but above the  $V_{IL}$  input threshold of the processor Reset pin. The processor must continuously apply strobes in this manner within a set period to verify proper software execution. A momentary Reset (500 msec minimum) is generated by the TC32M if a hardware or software failure keeps  $\overline{RS}$  from being strobed within the Watchdog Time-out period. This action typically initiates the processor's power-up routine. If the interruption persists, new Reset pulses are generated each time-out period until  $\overline{RS}$  is strobed. This time-out period is typically 700 msec.

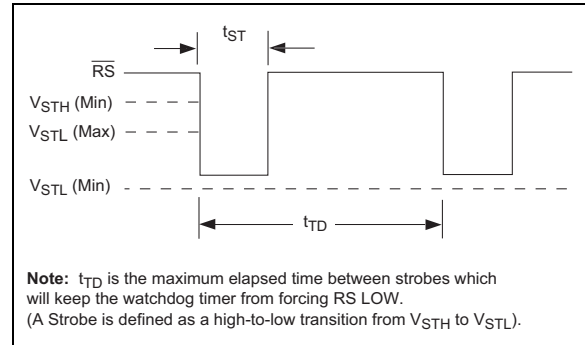

**FIGURE 3-1:** Watchdog Strobe

The software routine that drives the  $\overline{RS}$  strobe must be in a section of the program that executes frequently enough so the time between toggles is less than one Watchdog Time-out period. The strobe signal can be derived from microprocessor address, data and/or control signals. Typical circuit examples are shown in Figure .

### 3.3 Resistor Value Selection

The values of  $R_1$  and  $R_2$  must be chosen to ensure a valid low strobe level ( $V_{STL}$ ) on  $\overline{RS}$  when the processor I/O line is low. The use of 10 k $\Omega$ ,  $\pm 5\%$  tolerance resistors are recommended. These values result in a nominal strobe level of 2.5 on  $\overline{RS}$  (min/max of 2.13V/3.08V, assuming  $V_{DD} = 5.0V \pm 10\%$ ). Other resistor values can be used, so long as the additive tolerances of the power supply and resistor values result in a strobe that falls within  $V_{STH}$  and  $V_{STL}$  under all additive tolerance conditions.

# TC32M

## 3.4 External Override Reset Control

A built-in debounce circuit allows a push-button switch (PB) or other electronic signal to be wire-ORed to this pin as an external  $\overline{\text{Reset}}$  override control. The external  $\overline{\text{Reset}}$  is required to be an active low signal. Internally, this input is timed to provide a minimum  $\overline{\text{Reset}}$  pulse width of 500 msec. Reference Figure .

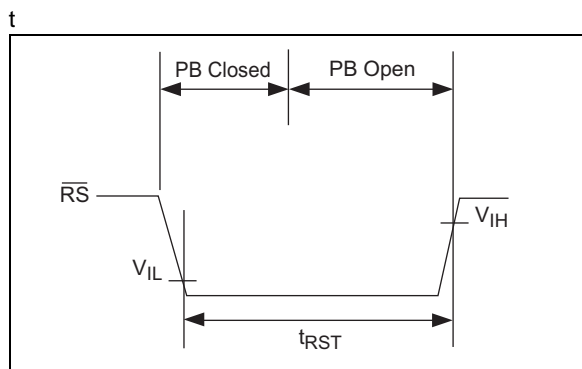

**FIGURE 3-2:**  $\overline{\text{RS}}$  Pulled Low By Push-Button Reset

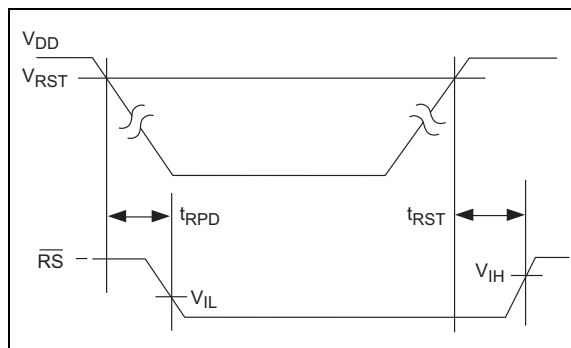

**FIGURE 3-3:** Power-Up/Down Reset Timing

## 3.5 Supply Monitor Noise Sensitivity

The TC32M is optimized for fast response to negative-going changes in  $V_{DD}$ . Systems with an inordinate amount of electrical noise on  $V_{DD}$  (such as systems using relays), may require a 0.01  $\mu\text{F}$  bypass capacitor to reduce detection sensitivity. This capacitor should be installed as close to the TC32M as possible to keep the capacitor lead length short.

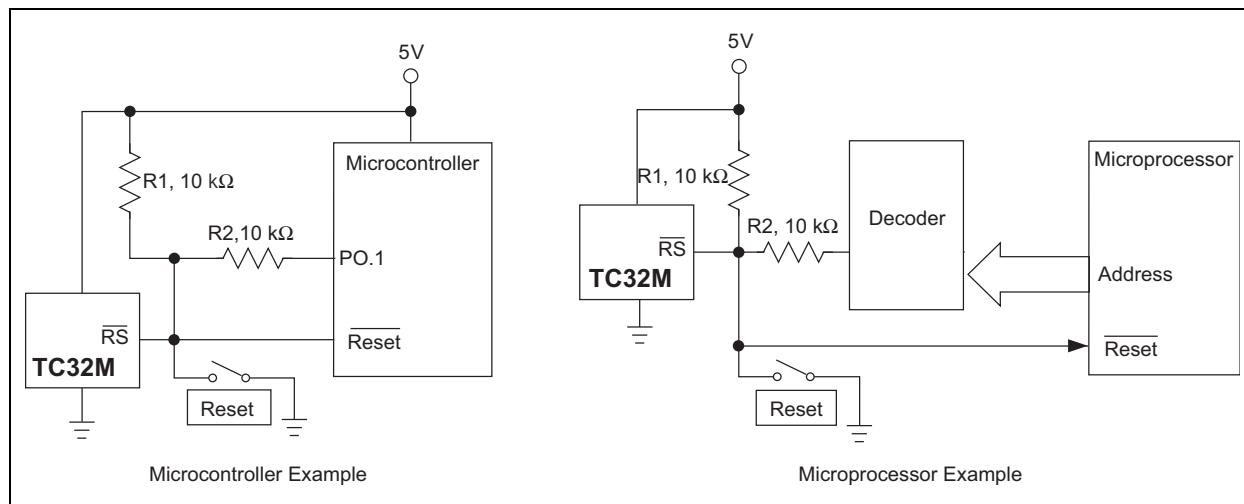

**FIGURE 3-4:** TC32M Hardware Connections ( $R_1, R_2$  Chosen To Meet  $V_{STH}, V_{STL}$ )

## 4.0 PACKAGING INFORMATION

### 4.1 Package Marking Information

Package marking data not available at this time.

### 4.2 Taping Form

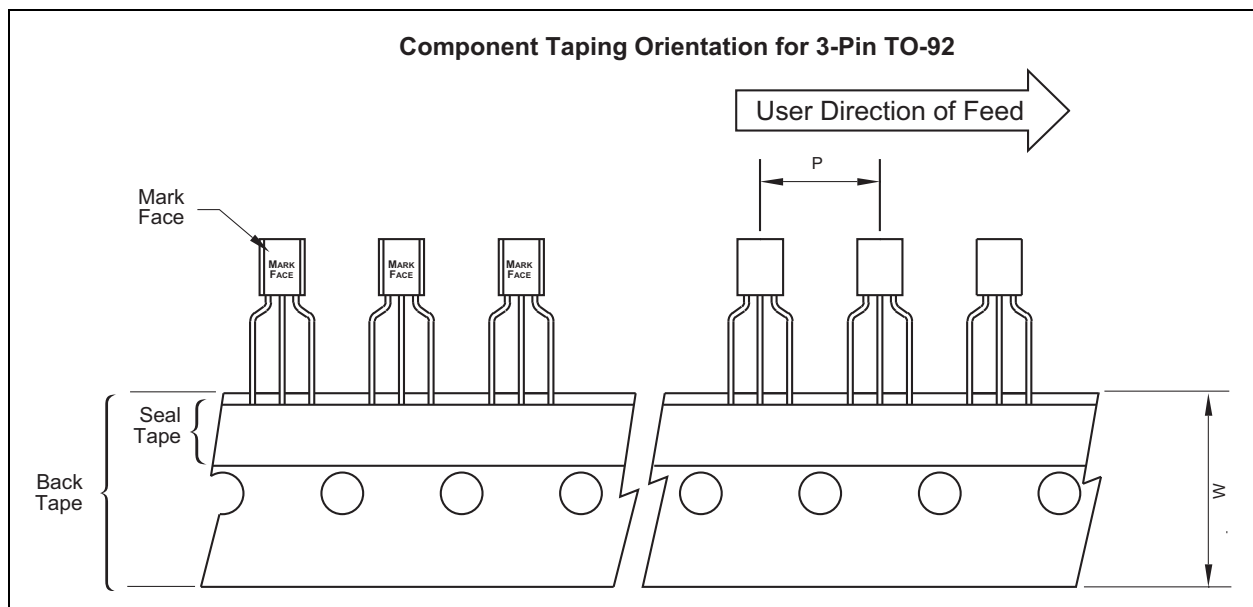
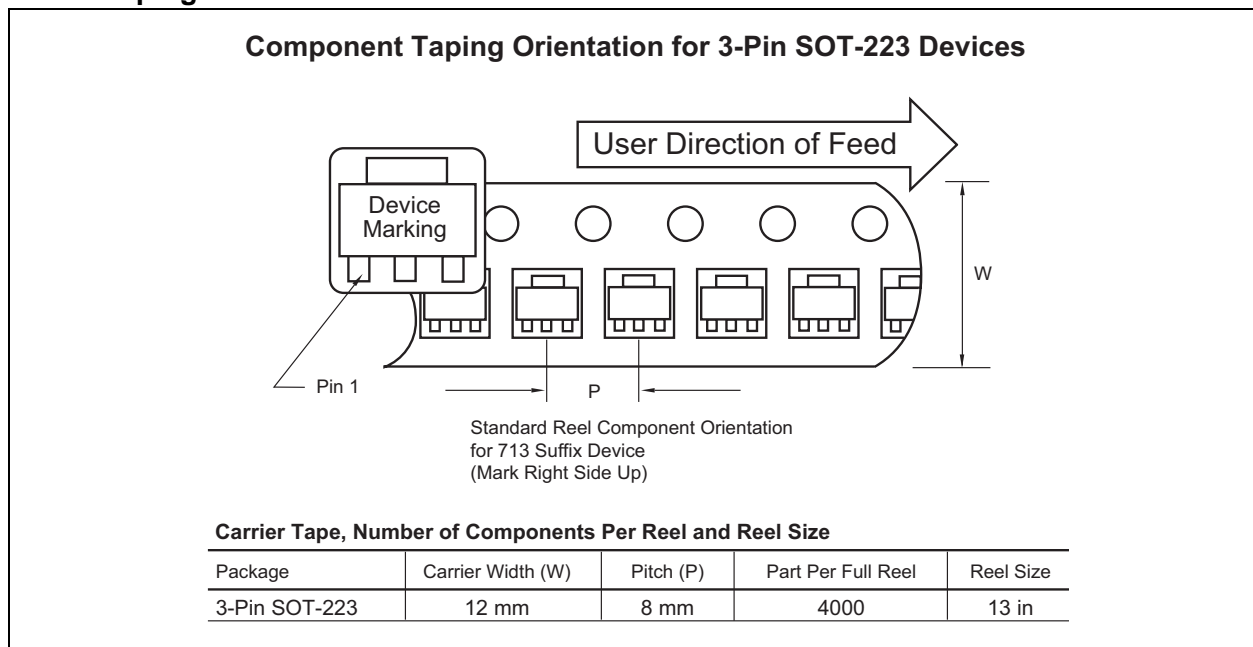

## 4.3 Package Dimensions

**Note:** For the most current package drawings, please see the Microchip Packaging Specification located at <http://www.microchip.com/packaging>

### 3-Pin SOT-223

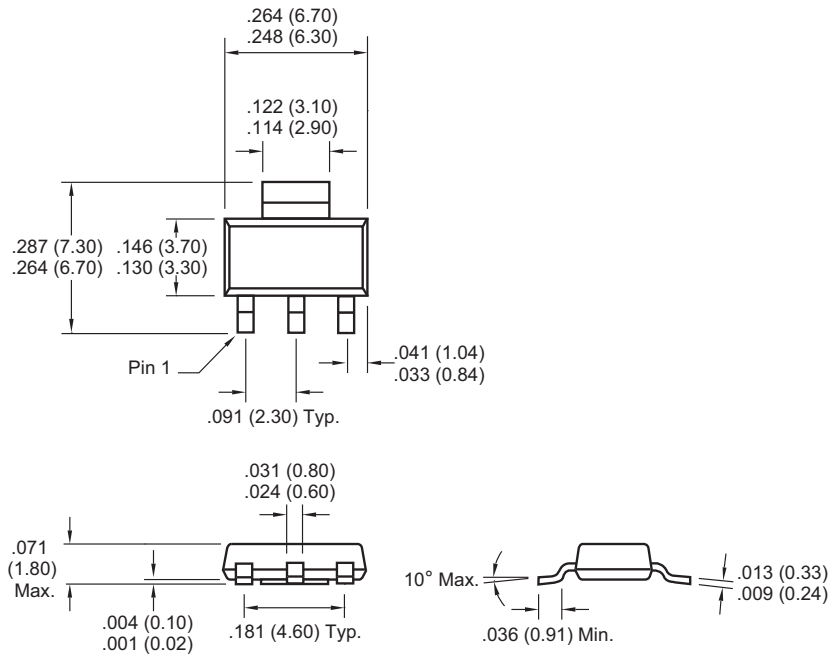

Dimensions: inches (mm)

**Note:** For the most current package drawings, please see the Microchip Packaging Specification located at <http://www.microchip.com/packaging>

### TO-92-3

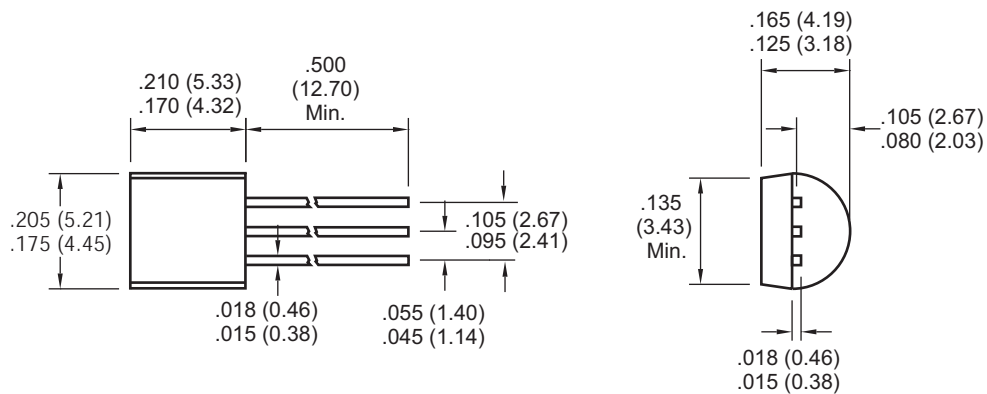

Dimensions: inches (mm)



## 5.0 REVISION HISTORY

### Revision D (December 2012)

Added a note to each package outline drawing.

# TC32M

---

NOTES:

## PRODUCT IDENTIFICATION SYSTEM

To order or obtain information, e.g., on pricing or delivery, refer to the factory or the listed sales office.

<b>PART CODE</b>	<b>TC32M</b>	<b>X</b>	<b>XX</b>
<b>Temperature:</b>	_____		
C: Commercial (0°C to +70°C)			
E: Extended (-40°C to +85°C)			
<b>Package Type:</b>	_____		
ZB: 3-Pin TO-92			
DB: 3-Pin SOT223			
DB713: 3-Pin Tape & Reel SOT223			

### Sales and Support

#### Data Sheets

Products supported by a preliminary Data Sheet may have an errata sheet describing minor operational differences and recommended workarounds. To determine if an errata sheet exists for a particular device, please contact one of the following:

1. Your local Microchip sales office
2. The Microchip Worldwide Site ([www.microchip.com](http://www.microchip.com))

Please specify which device, revision of silicon and Data Sheet (include Literature #) you are using.

#### New Customer Notification System

Register on our web site ([www.microchip.com/cn](http://www.microchip.com/cn)) to receive the most current information on our products.

# TC32M

---

NOTES:

---

**Note the following details of the code protection feature on Microchip devices:**

- Microchip products meet the specification contained in their particular Microchip Data Sheet.
- Microchip believes that its family of products is one of the most secure families of its kind on the market today, when used in the intended manner and under normal conditions.
- There are dishonest and possibly illegal methods used to breach the code protection feature. All of these methods, to our knowledge, require using the Microchip products in a manner outside the operating specifications contained in Microchip's Data Sheets. Most likely, the person doing so is engaged in theft of intellectual property.
- Microchip is willing to work with the customer who is concerned about the integrity of their code.
- Neither Microchip nor any other semiconductor manufacturer can guarantee the security of their code. Code protection does not mean that we are guaranteeing the product as “unbreakable.”

Code protection is constantly evolving. We at Microchip are committed to continuously improving the code protection features of our products. Attempts to break Microchip's code protection feature may be a violation of the Digital Millennium Copyright Act. If such acts allow unauthorized access to your software or other copyrighted work, you may have a right to sue for relief under that Act.

---

Information contained in this publication regarding device applications and the like is provided only for your convenience and may be superseded by updates. It is your responsibility to ensure that your application meets with your specifications. MICROCHIP MAKES NO REPRESENTATIONS OR WARRANTIES OF ANY KIND WHETHER EXPRESS OR IMPLIED, WRITTEN OR ORAL, STATUTORY OR OTHERWISE, RELATED TO THE INFORMATION, INCLUDING BUT NOT LIMITED TO ITS CONDITION, QUALITY, PERFORMANCE, MERCHANTABILITY OR FITNESS FOR PURPOSE. Microchip disclaims all liability arising from this information and its use. Use of Microchip devices in life support and/or safety applications is entirely at the buyer's risk, and the buyer agrees to defend, indemnify and hold harmless Microchip from any and all damages, claims, suits, or expenses resulting from such use. No licenses are conveyed, implicitly or otherwise, under any Microchip intellectual property rights.

**Trademarks**

The Microchip name and logo, the Microchip logo, dsPIC, FlashFlex, KEELOQ, KEELOQ logo, MPLAB, PIC, PICmicro, PICSTART, PIC<sup>32</sup> logo, rPIC, SST, SST Logo, SuperFlash and UNI/O are registered trademarks of Microchip Technology Incorporated in the U.S.A. and other countries.

FilterLab, Hampshire, HI-TECH C, Linear Active Thermistor, MTP, SEEVAL and The Embedded Control Solutions Company are registered trademarks of Microchip Technology Incorporated in the U.S.A.

Silicon Storage Technology is a registered trademark of Microchip Technology Inc. in other countries.

Analog-for-the-Digital Age, Application Maestro, BodyCom, chipKIT, chipKIT logo, CodeGuard, dsPICDEM, dsPICDEM.net, dsPICworks, dsSPEAK, ECAN, ECONOMONITOR, FanSense, HI-TIDE, In-Circuit Serial Programming, ICSP, Mindi, MiWi, MPASM, MPF, MPLAB Certified logo, MPLIB, MPLINK, mTouch, Omniclient Code Generation, PICC, PICC-18, PICDEM, PICDEM.net, PICkit, PICtail, REAL ICE, rLAB, Select Mode, SQI, Serial Quad I/O, Total Endurance, TSHARC, UniWinDriver, WiperLock, ZENA and Z-Scale are trademarks of Microchip Technology Incorporated in the U.S.A. and other countries.

SQTP is a service mark of Microchip Technology Incorporated in the U.S.A.

GestIC and ULPP are registered trademarks of Microchip Technology Germany II GmbH & Co. & KG, a subsidiary of Microchip Technology Inc., in other countries.

All other trademarks mentioned herein are property of their respective companies.

© 2001-2012, Microchip Technology Incorporated, Printed in the U.S.A., All Rights Reserved.

 Printed on recycled paper.

ISBN: 9781620767894

**QUALITY MANAGEMENT SYSTEM**  
**CERTIFIED BY DNV**  
**== ISO/TS 16949 ==**

*Microchip received ISO/TS-16949:2009 certification for its worldwide headquarters, design and wafer fabrication facilities in Chandler and Tempe, Arizona; Gresham, Oregon and design centers in California and India. The Company's quality system processes and procedures are for its PIC<sup>®</sup> MCUs and dsPIC<sup>®</sup> DSCs, KEELOQ<sup>®</sup> code hopping devices, Serial EEPROMs, microperipherals, nonvolatile memory and analog products. In addition, Microchip's quality system for the design and manufacture of development systems is ISO 9001:2000 certified.*



# MICROCHIP

## Worldwide Sales and Service

### AMERICAS

**Corporate Office**  
2355 West Chandler Blvd.  
Chandler, AZ 85224-6199  
Tel: 480-792-7200  
Fax: 480-792-7277  
Technical Support:  
<http://www.microchip.com/support>  
Web Address:  
[www.microchip.com](http://www.microchip.com)

**Atlanta**  
Duluth, GA  
Tel: 678-957-9614  
Fax: 678-957-1455

**Boston**  
Westborough, MA  
Tel: 774-760-0087  
Fax: 774-760-0088

**Chicago**  
Itasca, IL  
Tel: 630-285-0071  
Fax: 630-285-0075

**Cleveland**  
Independence, OH  
Tel: 216-447-0464  
Fax: 216-447-0643

**Dallas**  
Addison, TX  
Tel: 972-818-7423  
Fax: 972-818-2924

**Detroit**  
Farmington Hills, MI  
Tel: 248-538-2250  
Fax: 248-538-2260

**Indianapolis**  
Noblesville, IN  
Tel: 317-773-8323  
Fax: 317-773-5453

**Los Angeles**  
Mission Viejo, CA  
Tel: 949-462-9523  
Fax: 949-462-9608

**Santa Clara**  
Santa Clara, CA  
Tel: 408-961-6444  
Fax: 408-961-6445

**Toronto**  
Mississauga, Ontario,  
Canada  
Tel: 905-673-0699  
Fax: 905-673-6509

### ASIA/PACIFIC

**Asia Pacific Office**  
Suites 3707-14, 37th Floor  
Tower 6, The Gateway  
Harbour City, Kowloon  
Hong Kong  
Tel: 852-2401-1200  
Fax: 852-2401-3431

**Australia - Sydney**  
Tel: 61-2-9868-6733  
Fax: 61-2-9868-6755

**China - Beijing**  
Tel: 86-10-8569-7000  
Fax: 86-10-8528-2104

**China - Chengdu**  
Tel: 86-28-8665-5511  
Fax: 86-28-8665-7889

**China - Chongqing**  
Tel: 86-23-8980-9588  
Fax: 86-23-8980-9500

**China - Hangzhou**  
Tel: 86-571-2819-3187  
Fax: 86-571-2819-3189

**China - Hong Kong SAR**  
Tel: 852-2943-5100  
Fax: 852-2401-3431

**China - Nanjing**  
Tel: 86-25-8473-2460  
Fax: 86-25-8473-2470

**China - Qingdao**  
Tel: 86-532-8502-7355  
Fax: 86-532-8502-7205

**China - Shanghai**  
Tel: 86-21-5407-5533  
Fax: 86-21-5407-5066

**China - Shenyang**  
Tel: 86-24-2334-2829  
Fax: 86-24-2334-2393

**China - Shenzhen**  
Tel: 86-755-8864-2200  
Fax: 86-755-8203-1760

**China - Wuhan**  
Tel: 86-27-5980-5300  
Fax: 86-27-5980-5118

**China - Xian**  
Tel: 86-29-8833-7252  
Fax: 86-29-8833-7256

**China - Xiamen**  
Tel: 86-592-2388138  
Fax: 86-592-2388130

**China - Zhuhai**  
Tel: 86-756-3210040  
Fax: 86-756-3210049

### ASIA/PACIFIC

**India - Bangalore**  
Tel: 91-80-3090-4444  
Fax: 91-80-3090-4123

**India - New Delhi**  
Tel: 91-11-4160-8631  
Fax: 91-11-4160-8632

**India - Pune**  
Tel: 91-20-2566-1512  
Fax: 91-20-2566-1513

**Japan - Osaka**  
Tel: 81-66-152-7160  
Fax: 81-66-152-9310

**Japan - Yokohama**  
Tel: 81-45-471-6166  
Fax: 81-45-471-6122

**Korea - Daegu**  
Tel: 82-53-744-4301  
Fax: 82-53-744-4302

**Korea - Seoul**  
Tel: 82-2-554-7200  
Fax: 82-2-558-5932 or  
82-2-558-5934

**Malaysia - Kuala Lumpur**  
Tel: 60-3-6201-9857  
Fax: 60-3-6201-9859

**Malaysia - Penang**  
Tel: 60-4-227-8870  
Fax: 60-4-227-4068

**Philippines - Manila**  
Tel: 63-2-634-9065  
Fax: 63-2-634-9069

**Singapore**  
Tel: 65-6334-8870  
Fax: 65-6334-8850

**Taiwan - Hsin Chu**  
Tel: 886-3-5778-366  
Fax: 886-3-5770-955

**Taiwan - Kaohsiung**  
Tel: 886-7-213-7828  
Fax: 886-7-330-9305

**Taiwan - Taipei**  
Tel: 886-2-2508-8600  
Fax: 886-2-2508-0102

**Thailand - Bangkok**  
Tel: 66-2-694-1351  
Fax: 66-2-694-1350

### EUROPE

**Austria - Wels**  
Tel: 43-7242-2244-39  
Fax: 43-7242-2244-393

**Denmark - Copenhagen**  
Tel: 45-4450-2828  
Fax: 45-4485-2829

**France - Paris**  
Tel: 33-1-69-53-63-20  
Fax: 33-1-69-30-90-79

**Germany - Munich**  
Tel: 49-89-627-144-0  
Fax: 49-89-627-144-44

**Italy - Milan**  
Tel: 39-0331-742611  
Fax: 39-0331-466781

**Netherlands - Drunen**  
Tel: 31-416-690399  
Fax: 31-416-690340

**Spain - Madrid**  
Tel: 34-91-708-08-90  
Fax: 34-91-708-08-91

**UK - Wokingham**  
Tel: 44-118-921-5869  
Fax: 44-118-921-5820

11/27/12



Компания «ЭлектроПласт» предлагает заключение долгосрочных отношений при поставках импортных электронных компонентов на взаимовыгодных условиях!

Наши преимущества:

- Оперативные поставки широкого спектра электронных компонентов отечественного и импортного производства напрямую от производителей и с крупнейших мировых складов;
- Поставка более 17-ти миллионов наименований электронных компонентов;
- Поставка сложных, дефицитных, либо снятых с производства позиций;
- Оперативные сроки поставки под заказ (от 5 рабочих дней);
- Экспресс доставка в любую точку России;
- Техническая поддержка проекта, помощь в подборе аналогов, поставка прототипов;
- Система менеджмента качества сертифицирована по Международному стандарту ISO 9001;
- Лицензия ФСБ на осуществление работ с использованием сведений, составляющих государственную тайну;
- Поставка специализированных компонентов (Xilinx, Altera, Analog Devices, Intersil, Interpoint, Microsemi, Aeroflex, Peregrine, Syfer, Eurofarad, Texas Instrument, Miteq, Cobham, E2V, MA-COM, Hittite, Mini-Circuits, General Dynamics и др.);

Помимо этого, одним из направлений компании «ЭлектроПласт» является направление «Источники питания». Мы предлагаем Вам помощь Конструкторского отдела:

- Подбор оптимального решения, техническое обоснование при выборе компонента;
- Подбор аналогов;
- Консультации по применению компонента;
- Поставка образцов и прототипов;
- Техническая поддержка проекта;
- Защита от снятия компонента с производства.



#### Как с нами связаться

**Телефон:** 8 (812) 309 58 32 (многоканальный)

**Факс:** 8 (812) 320-02-42

**Электронная почта:** [org@eplast1.ru](mailto:org@eplast1.ru)

**Адрес:** 198099, г. Санкт-Петербург, ул. Калинина, дом 2, корпус 4, литера А.