

ECONOMONITOR™ – 3-Pin System Supervisor with Power Supply Monitor and Watchdog

Features:

- Incorporates the Functionality of the Industry Standard TC1232 (Processor Monitor, Watchdog and Manual Override Reset Controller) into a Small, Lower Cost Package
- Guards Against Unstable Processor Operation Resulting from Power “Brown-Out”
- Automatically Halts and Restarts an Out-of-Control Microprocessor
- Output can be Wire-ORed, or Hooked to Manual Reset Push-button Switch
- Space-Saving 3-Pin TO-92 or SOT-223 Package

Applications:

- All Microprocessor-Based Systems
- Battery Powered Computers and Controllers
- Automotive Systems
- Intelligent Instruments
- Critical Processor Monitoring
- Embedded Controllers

Device Selection Table

Part Number	Package	Temp. Range
TC32MCDB	SOT-223	0°C to +70°C
TC32MCZB	TO-92	0°C to +70°C
TC32MEDB	SOT-223	-40°C to +85°C
TC32MEZB	TO-92	-40°C to +85°C

Package Type

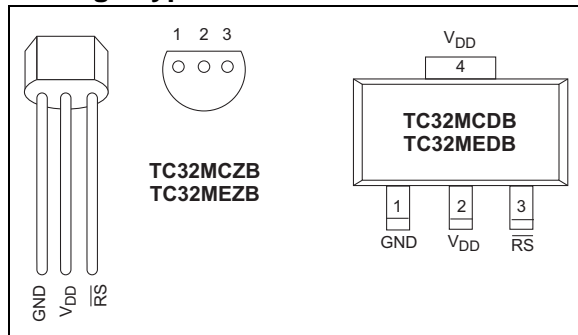

General Description:

The TC32M is a fully-integrated processor supervisor in a 3-pin package. It provides three important functions to safeguard processor sanity: precision power on/off Reset control, Watchdog Timer and external Reset override.

On power-up, the TC32M holds the processor in the Reset state for a minimum of 500 msec after V_{DD} is within tolerance to ensure a stable system start-up. Microprocessor sanity is monitored by the on-board Watchdog circuit. The microprocessor must provide a high-to-low level shift (through an external resistor divider) on the RS pin of the TC32M. Should the processor fail to supply this signal within the specified time-out period (typically 700 msec), an out-of-control processor is indicated and the TC32M issues a processor Reset as a result.

The output of the TC32M can be wire-ORed with a push-button switch (or electronic signal) to override the TC32M and unconditionally reset the processor. When connected to a push-button switch, the TC32M provides contact debounce.

The TC32M is packaged in a space-saving TO-92 or SOT-223 package. It provides all of the functionality of the industry standard TC1232 in a smaller, lower cost configuration.

TC32M

Functional Block Diagram

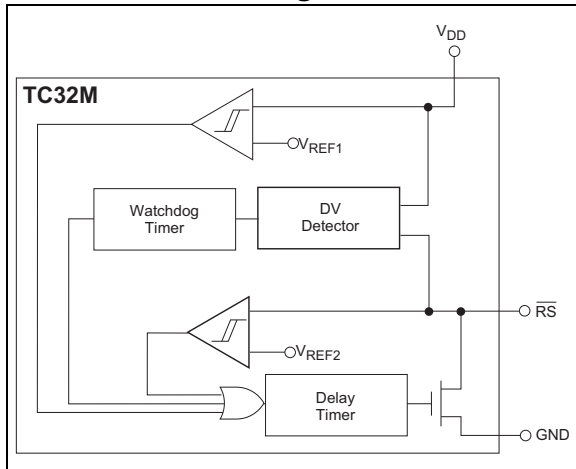

Typical Operating Circuit

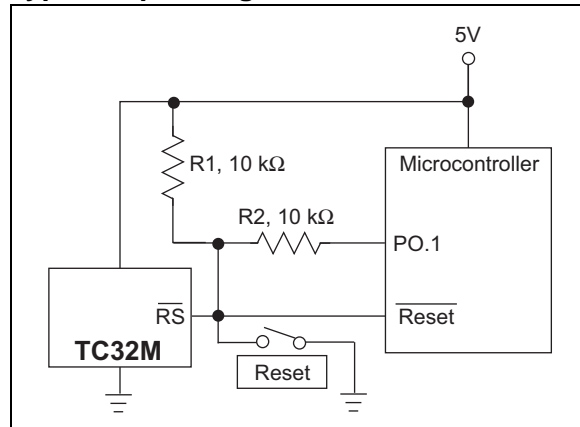

1.0 ELECTRICAL CHARACTERISTICS

Absolute Maximum Ratings*

Supply Voltage (V_{DD} to GND)	+6.0V
Input Voltage Any Pin..... (GND – 0.3V) to (V_{DD} +0.3V)	
Operating Temperature Range	
TC32MC Package.....	0°C to +70°C
TC32ME Package.....	-40°C to +85°C
Storage Temperature Range	-65°C to +150°C

*Stresses above those listed under “Absolute Maximum Ratings” may cause permanent damage to the device. These are stress ratings only and functional operation of the device at these or any other conditions above those indicated in the operation sections of the specifications is not implied. Exposure to Absolute Maximum Rating conditions for extended periods may affect device reliability.

TC32M ELECTRICAL SPECIFICATIONS

Recommended DC Operating Conditions: $T_A = -40^\circ\text{C}$ to $+85^\circ\text{C}$ unless otherwise noted.						
Symbol	Parameter	Min	Typ	Max	Units	Test Conditions
V_{DD}	Supply Voltage	4.5	—	5.5	V	
V_{IH}	\overline{RS} Input HIGH Level for PB	2.0	—	—	V	
V_{IL}	\overline{RS} Input LOW Level for PB	—	—	0.3	V	
DC Electrical Characteristics: $V_{DD} = 4.5\text{V}$ to 5.5V , $T_A = -40^\circ\text{C}$ to $+85^\circ\text{C}$ unless otherwise noted.						
Symbol	Parameter	Min	Typ	Max	Units	Test Conditions
I_{IL}	\overline{RS} Input Leakage	-1	—	+1	mA	
I_{OL}	\overline{RS} Output Current	2.0	10	—	mA	$V_{OL} = 0.4\text{V}$
I_{CC}	Operating Current	—	50	200	μA	Note 1
V_{STH}	\overline{RS} Strobe HIGH Level	$(V_{DD} - 0.5\text{V})$	—	—	V	Figure 3-1
V_{STL}	\overline{RS} Strobe LOW Level	2.00	—	$(V_{DD} - 1.5\text{V})$	V	Figure 3-1
V_{RST}	Reset Threshold	4.25	—	4.50	V	V_{DD} Falling (Note 2 , Figure 3-3)
Capacitance Electrical Characteristics: $T_A = 25^\circ\text{C}$ unless otherwise noted.						
Symbol	Parameter	Min	Typ	Max	Units	Test Conditions
C_{IN}	Input Capacitance	—	—	5	pF	
C_{OUT}	Output Capacitance	—	—	7	pF	
AC Electrical Characteristics: $T_A = -40^\circ\text{C}$ to $+85^\circ\text{C}$, $V_{DD} = 5\text{V} \pm 10\%$, unless otherwise noted.						
Symbol	Parameter	Min	Typ	Max	Units	Test Conditions
t_{RST}	Reset Active Time	500	700	900	msec	Figure
t_{ST}	\overline{RS} Strobe Pulse Width	500	—	—	nsec	Figure 3-1
t_{TD}	Watchdog Time-out Period	500	700	900	msec	Figure 3-1
t_{RPD}	V_{DD} Detect to \overline{RS} LOW	—	—	—	nsec	Figure 3-1

Note 1: No output load.

Note 2: All voltages referenced to ground.

TC32M

2.0 PIN DESCRIPTIONS

The descriptions of the pins are listed in Table 2-1.

TABLE 2-1: PIN FUNCTION TABLE

Pin No. (SOT-223, TO-92)	Symbol	Description
1	GND	Ground.
2	V _{DD}	The +5V power supply input.
3	RS	$\overline{\text{Reset/Strobe}}$ (Bidirectional). The open drain goes active if: V _{DD} falls below 4.5V nominal. If pulled low by an external electronic signal or switch closure. If the Watchdog is not strobed within the minimum Watchdog Time-out period. During power-up and power-down. In the Input mode, $\overline{\text{RS}}$ connects to a voltage level shift network (typically a resistor divider to V _{DD} .) The Watchdog Timer is reset when processor causes a voltage level $\leq V_{\text{STL}}$ to be applied to $\overline{\text{RS}}$.
4	V _{DD}	The +5V power supply input (SOT-223 only).

3.0 DETAILED DESCRIPTION

The TC32M provides three important functions to safeguard stable processor operation: precision processor monitor, Watchdog sanity timer and external override Reset control.

3.1 Processor Monitor

The \overline{RS} pin is immediately driven low any time V_{DD} is below the nominal threshold voltage. As a result, this pin is LOW when power is initially applied, holding the processor in its Reset state. \overline{RS} remains low for a minimum of 500 msec after V_{DD} is within tolerance to allow the power supply and processor to stabilize.

3.2 Watchdog Timer

The processor drives the \overline{RS} pin with an input/output (I/O) line in series with a resistor voltage divider to V_{DD} . Pulling the bottom resistor of this divider low results in an internal voltage change (*strobe*) sufficient to reset the Watchdog Timer, but above the V_{IL} input threshold of the processor Reset pin. The processor must continuously apply strobes in this manner within a set period to verify proper software execution. A momentary Reset (500 msec minimum) is generated by the TC32M if a hardware or software failure keeps \overline{RS} from being strobed within the Watchdog Time-out period. This action typically initiates the processor's power-up routine. If the interruption persists, new Reset pulses are generated each time-out period until \overline{RS} is strobed. This time-out period is typically 700 msec.

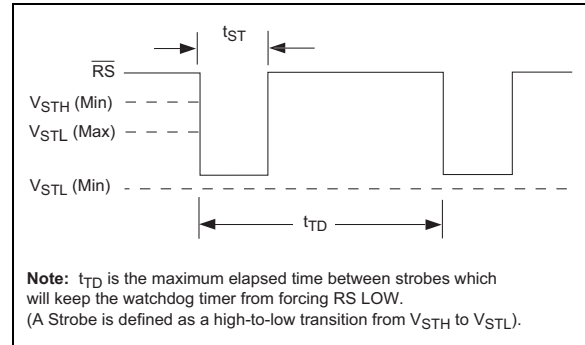

FIGURE 3-1: Watchdog Strobe

The software routine that drives the \overline{RS} strobe must be in a section of the program that executes frequently enough so the time between toggles is less than one Watchdog Time-out period. The strobe signal can be derived from microprocessor address, data and/or control signals. Typical circuit examples are shown in Figure .

3.3 Resistor Value Selection

The values of R_1 and R_2 must be chosen to ensure a valid low strobe level (V_{STL}) on \overline{RS} when the processor I/O line is low. The use of 10 k Ω , $\pm 5\%$ tolerance resistors are recommended. These values result in a nominal strobe level of 2.5 on \overline{RS} (min/max of 2.13V/3.08V, assuming $V_{DD} = 5.0V \pm 10\%$). Other resistor values can be used, so long as the additive tolerances of the power supply and resistor values result in a strobe that falls within V_{STH} and V_{STL} under all additive tolerance conditions.

TC32M

3.4 External Override Reset Control

A built-in debounce circuit allows a push-button switch (PB) or other electronic signal to be wire-ORed to this pin as an external $\overline{\text{Reset}}$ override control. The external $\overline{\text{Reset}}$ is required to be an active low signal. Internally, this input is timed to provide a minimum $\overline{\text{Reset}}$ pulse width of 500 msec. Reference Figure .

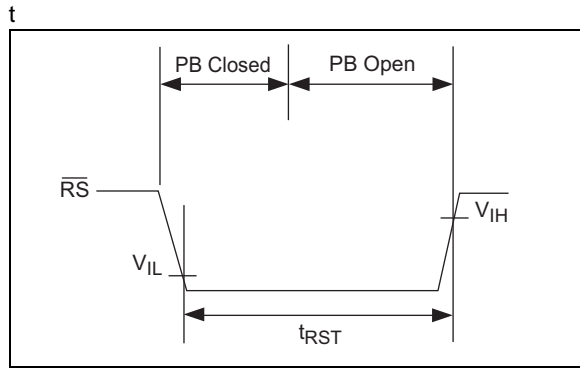

FIGURE 3-2: $\overline{\text{RS}}$ Pulled Low By Push-Button Reset

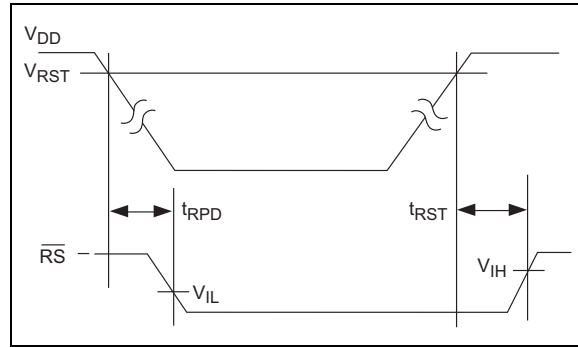

FIGURE 3-3: Power-Up/Down Reset Timing

3.5 Supply Monitor Noise Sensitivity

The TC32M is optimized for fast response to negative-going changes in V_{DD} . Systems with an inordinate amount of electrical noise on V_{DD} (such as systems using relays), may require a 0.01 μF bypass capacitor to reduce detection sensitivity. This capacitor should be installed as close to the TC32M as possible to keep the capacitor lead length short.

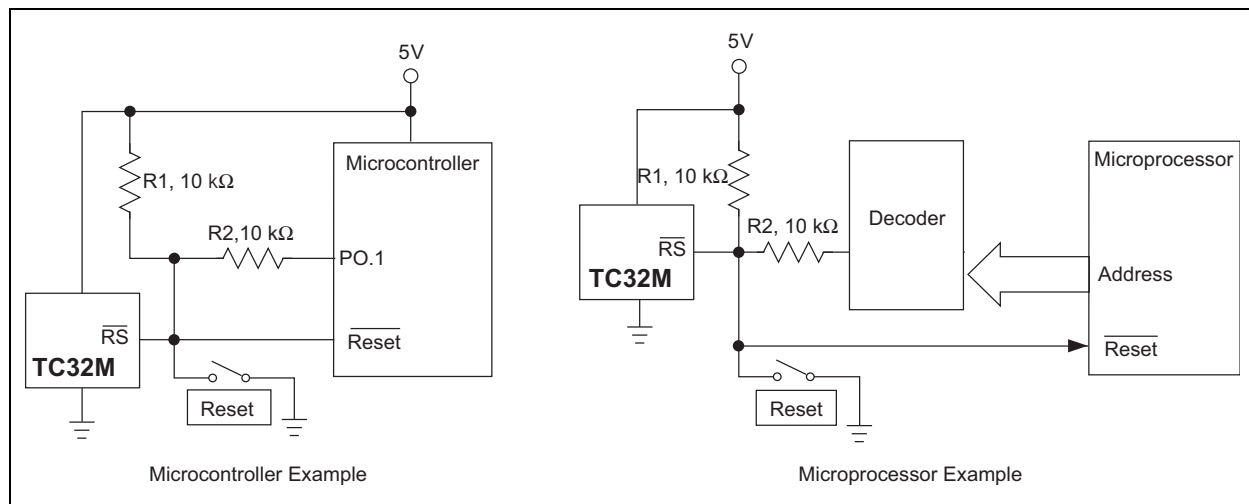

FIGURE 3-4: TC32M Hardware Connections (R_1, R_2 Chosen To Meet V_{STH}, V_{STL})

4.0 PACKAGING INFORMATION

4.1 Package Marking Information

Package marking data not available at this time.

4.2 Taping Form

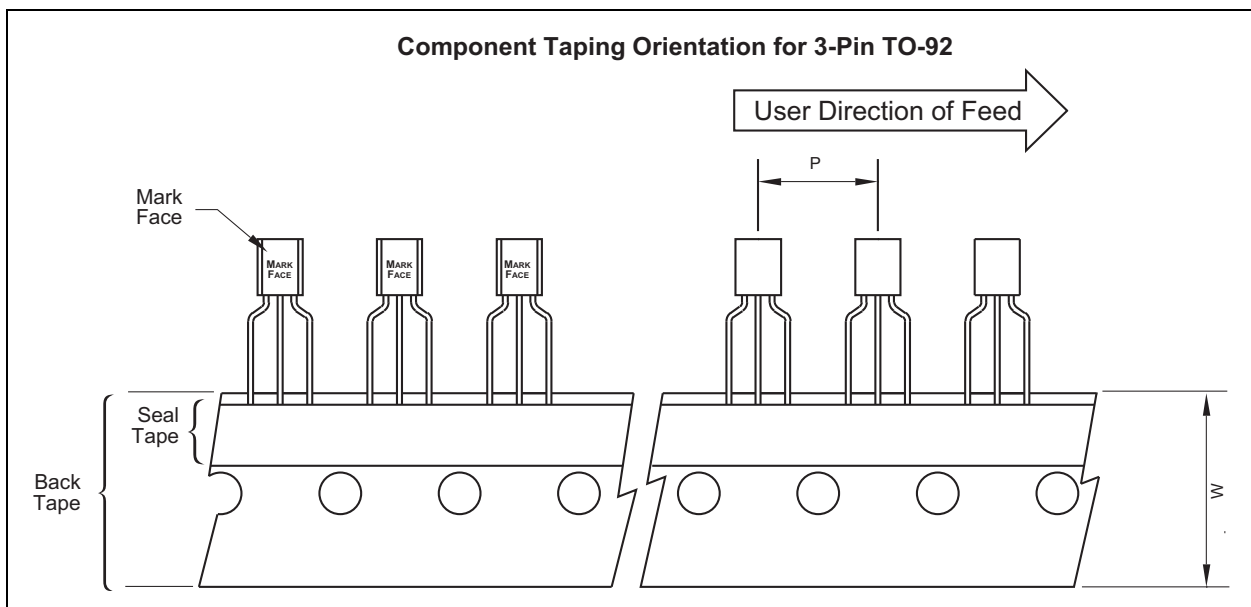
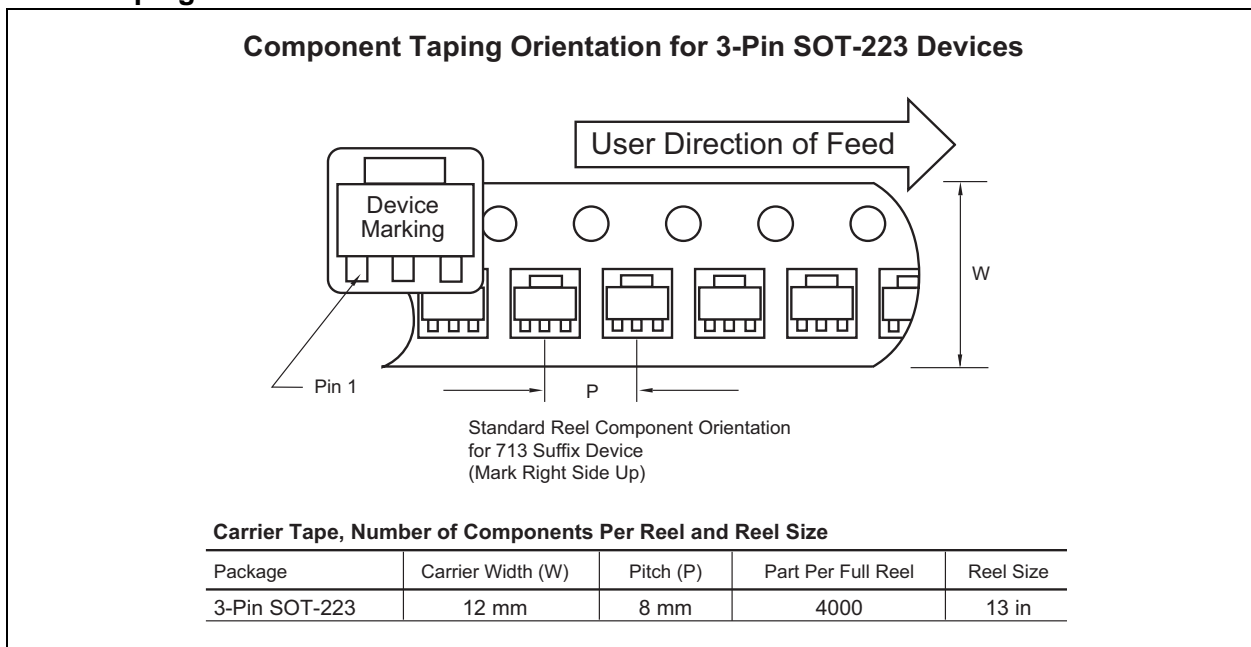

4.3 Package Dimensions

Note: For the most current package drawings, please see the Microchip Packaging Specification located at <http://www.microchip.com/packaging>

3-Pin SOT-223

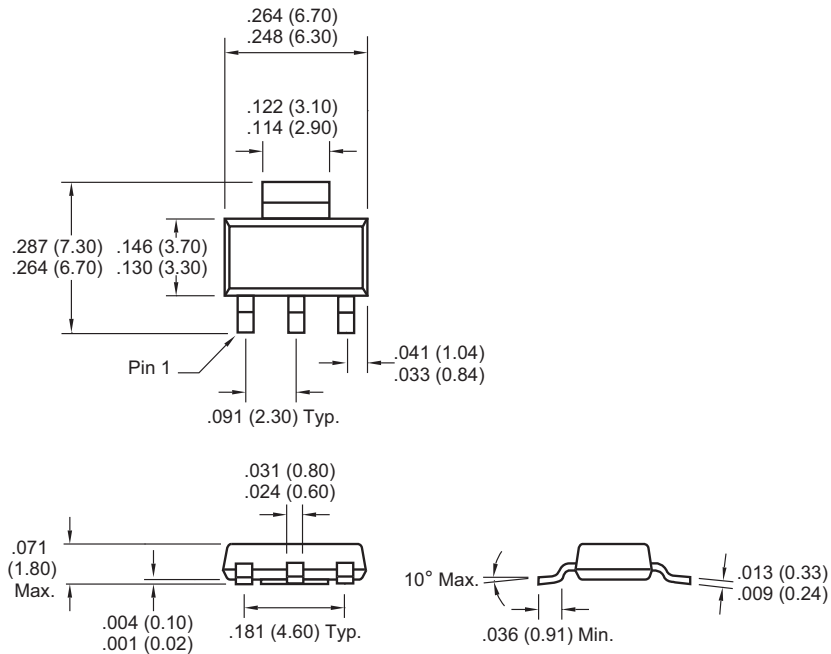

Dimensions: inches (mm)

Note: For the most current package drawings, please see the Microchip Packaging Specification located at <http://www.microchip.com/packaging>

TO-92-3

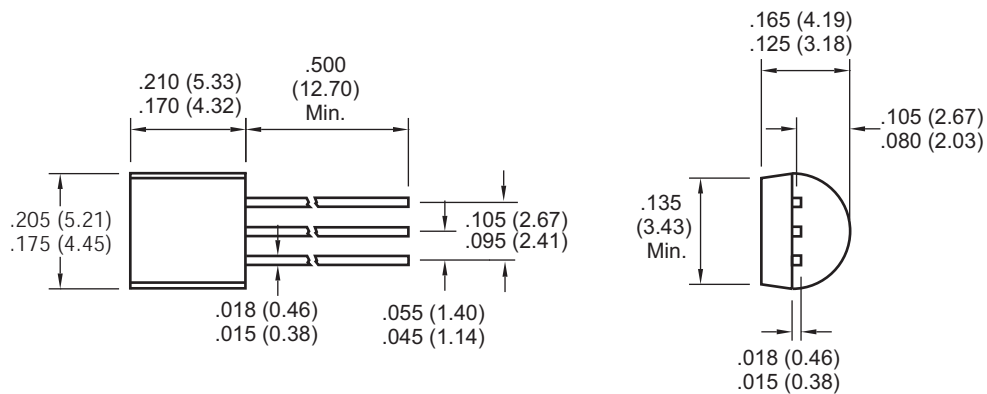

Dimensions: inches (mm)

5.0 REVISION HISTORY

Revision D (December 2012)

Added a note to each package outline drawing.

TC32M

NOTES:

PRODUCT IDENTIFICATION SYSTEM

To order or obtain information, e.g., on pricing or delivery, refer to the factory or the listed sales office.

PART CODE	TC32M	X	XX
Temperature:	_____		
C: Commercial (0°C to +70°C)			
E: Extended (-40°C to +85°C)			
Package Type:	_____		
ZB: 3-Pin TO-92			
DB: 3-Pin SOT223			
DB713: 3-Pin Tape & Reel SOT223			

Sales and Support

Data Sheets

Products supported by a preliminary Data Sheet may have an errata sheet describing minor operational differences and recommended workarounds. To determine if an errata sheet exists for a particular device, please contact one of the following:

1. Your local Microchip sales office
2. The Microchip Worldwide Site (www.microchip.com)

Please specify which device, revision of silicon and Data Sheet (include Literature #) you are using.

New Customer Notification System

Register on our web site (www.microchip.com/cn) to receive the most current information on our products.

TC32M

NOTES:

Note the following details of the code protection feature on Microchip devices:

- Microchip products meet the specification contained in their particular Microchip Data Sheet.
- Microchip believes that its family of products is one of the most secure families of its kind on the market today, when used in the intended manner and under normal conditions.
- There are dishonest and possibly illegal methods used to breach the code protection feature. All of these methods, to our knowledge, require using the Microchip products in a manner outside the operating specifications contained in Microchip's Data Sheets. Most likely, the person doing so is engaged in theft of intellectual property.
- Microchip is willing to work with the customer who is concerned about the integrity of their code.
- Neither Microchip nor any other semiconductor manufacturer can guarantee the security of their code. Code protection does not mean that we are guaranteeing the product as “unbreakable.”

Code protection is constantly evolving. We at Microchip are committed to continuously improving the code protection features of our products. Attempts to break Microchip's code protection feature may be a violation of the Digital Millennium Copyright Act. If such acts allow unauthorized access to your software or other copyrighted work, you may have a right to sue for relief under that Act.

Information contained in this publication regarding device applications and the like is provided only for your convenience and may be superseded by updates. It is your responsibility to ensure that your application meets with your specifications. MICROCHIP MAKES NO REPRESENTATIONS OR WARRANTIES OF ANY KIND WHETHER EXPRESS OR IMPLIED, WRITTEN OR ORAL, STATUTORY OR OTHERWISE, RELATED TO THE INFORMATION, INCLUDING BUT NOT LIMITED TO ITS CONDITION, QUALITY, PERFORMANCE, MERCHANTABILITY OR FITNESS FOR PURPOSE. Microchip disclaims all liability arising from this information and its use. Use of Microchip devices in life support and/or safety applications is entirely at the buyer's risk, and the buyer agrees to defend, indemnify and hold harmless Microchip from any and all damages, claims, suits, or expenses resulting from such use. No licenses are conveyed, implicitly or otherwise, under any Microchip intellectual property rights.

Trademarks

The Microchip name and logo, the Microchip logo, dsPIC, FlashFlex, KEELOQ, KEELOQ logo, MPLAB, PIC, PICmicro, PICSTART, PIC³² logo, rPIC, SST, SST Logo, SuperFlash and UNI/O are registered trademarks of Microchip Technology Incorporated in the U.S.A. and other countries.

FilterLab, Hampshire, HI-TECH C, Linear Active Thermistor, MTP, SEEVAL and The Embedded Control Solutions Company are registered trademarks of Microchip Technology Incorporated in the U.S.A.

Silicon Storage Technology is a registered trademark of Microchip Technology Inc. in other countries.

Analog-for-the-Digital Age, Application Maestro, BodyCom, chipKIT, chipKIT logo, CodeGuard, dsPICDEM, dsPICDEM.net, dsPICworks, dsSPEAK, ECAN, ECONOMONITOR, FanSense, HI-TIDE, In-Circuit Serial Programming, ICSP, Mindi, MiWi, MPASM, MPF, MPLAB Certified logo, MPLIB, MPLINK, mTouch, Omniclient Code Generation, PICC, PICC-18, PICDEM, PICDEM.net, PICkit, PICtail, REAL ICE, rLAB, Select Mode, SQI, Serial Quad I/O, Total Endurance, TSHARC, UniWinDriver, WiperLock, ZENA and Z-Scale are trademarks of Microchip Technology Incorporated in the U.S.A. and other countries.

SQTP is a service mark of Microchip Technology Incorporated in the U.S.A.

GestIC and ULPP are registered trademarks of Microchip Technology Germany II GmbH & Co. & KG, a subsidiary of Microchip Technology Inc., in other countries.

All other trademarks mentioned herein are property of their respective companies.

© 2001-2012, Microchip Technology Incorporated, Printed in the U.S.A., All Rights Reserved.

 Printed on recycled paper.

ISBN: 9781620767894

QUALITY MANAGEMENT SYSTEM
CERTIFIED BY DNV
== ISO/TS 16949 ==

Microchip received ISO/TS-16949:2009 certification for its worldwide headquarters, design and wafer fabrication facilities in Chandler and Tempe, Arizona; Gresham, Oregon and design centers in California and India. The Company's quality system processes and procedures are for its PIC[®] MCUs and dsPIC[®] DSCs, KEELOQ[®] code hopping devices, Serial EEPROMs, microperipherals, nonvolatile memory and analog products. In addition, Microchip's quality system for the design and manufacture of development systems is ISO 9001:2000 certified.



MICROCHIP

Worldwide Sales and Service

AMERICAS

Corporate Office
2355 West Chandler Blvd.
Chandler, AZ 85224-6199
Tel: 480-792-7200
Fax: 480-792-7277
Technical Support:
<http://www.microchip.com/support>
Web Address:
www.microchip.com

Atlanta
Duluth, GA
Tel: 678-957-9614
Fax: 678-957-1455

Boston
Westborough, MA
Tel: 774-760-0087
Fax: 774-760-0088

Chicago
Itasca, IL
Tel: 630-285-0071
Fax: 630-285-0075

Cleveland
Independence, OH
Tel: 216-447-0464
Fax: 216-447-0643

Dallas
Addison, TX
Tel: 972-818-7423
Fax: 972-818-2924

Detroit
Farmington Hills, MI
Tel: 248-538-2250
Fax: 248-538-2260

Indianapolis
Noblesville, IN
Tel: 317-773-8323
Fax: 317-773-5453

Los Angeles
Mission Viejo, CA
Tel: 949-462-9523
Fax: 949-462-9608

Santa Clara
Santa Clara, CA
Tel: 408-961-6444
Fax: 408-961-6445

Toronto
Mississauga, Ontario,
Canada
Tel: 905-673-0699
Fax: 905-673-6509

ASIA/PACIFIC

Asia Pacific Office
Suites 3707-14, 37th Floor
Tower 6, The Gateway
Harbour City, Kowloon
Hong Kong
Tel: 852-2401-1200
Fax: 852-2401-3431

Australia - Sydney
Tel: 61-2-9868-6733
Fax: 61-2-9868-6755

China - Beijing
Tel: 86-10-8569-7000
Fax: 86-10-8528-2104

China - Chengdu
Tel: 86-28-8665-5511
Fax: 86-28-8665-7889

China - Chongqing
Tel: 86-23-8980-9588
Fax: 86-23-8980-9500

China - Hangzhou
Tel: 86-571-2819-3187
Fax: 86-571-2819-3189

China - Hong Kong SAR
Tel: 852-2943-5100
Fax: 852-2401-3431

China - Nanjing
Tel: 86-25-8473-2460
Fax: 86-25-8473-2470

China - Qingdao
Tel: 86-532-8502-7355
Fax: 86-532-8502-7205

China - Shanghai
Tel: 86-21-5407-5533
Fax: 86-21-5407-5066

China - Shenyang
Tel: 86-24-2334-2829
Fax: 86-24-2334-2393

China - Shenzhen
Tel: 86-755-8864-2200
Fax: 86-755-8203-1760

China - Wuhan
Tel: 86-27-5980-5300
Fax: 86-27-5980-5118

China - Xian
Tel: 86-29-8833-7252
Fax: 86-29-8833-7256

China - Xiamen
Tel: 86-592-2388138
Fax: 86-592-2388130

China - Zhuhai
Tel: 86-756-3210040
Fax: 86-756-3210049

ASIA/PACIFIC

India - Bangalore
Tel: 91-80-3090-4444
Fax: 91-80-3090-4123

India - New Delhi
Tel: 91-11-4160-8631
Fax: 91-11-4160-8632

India - Pune
Tel: 91-20-2566-1512
Fax: 91-20-2566-1513

Japan - Osaka
Tel: 81-66-152-7160
Fax: 81-66-152-9310

Japan - Yokohama
Tel: 81-45-471-6166
Fax: 81-45-471-6122

Korea - Daegu
Tel: 82-53-744-4301
Fax: 82-53-744-4302

Korea - Seoul
Tel: 82-2-554-7200
Fax: 82-2-558-5932 or
82-2-558-5934

Malaysia - Kuala Lumpur
Tel: 60-3-6201-9857
Fax: 60-3-6201-9859

Malaysia - Penang
Tel: 60-4-227-8870
Fax: 60-4-227-4068

Philippines - Manila
Tel: 63-2-634-9065
Fax: 63-2-634-9069

Singapore
Tel: 65-6334-8870
Fax: 65-6334-8850

Taiwan - Hsin Chu
Tel: 886-3-5778-366
Fax: 886-3-5770-955

Taiwan - Kaohsiung
Tel: 886-7-213-7828
Fax: 886-7-330-9305

Taiwan - Taipei
Tel: 886-2-2508-8600
Fax: 886-2-2508-0102

Thailand - Bangkok
Tel: 66-2-694-1351
Fax: 66-2-694-1350

EUROPE

Austria - Wels
Tel: 43-7242-2244-39
Fax: 43-7242-2244-393

Denmark - Copenhagen
Tel: 45-4450-2828
Fax: 45-4485-2829

France - Paris
Tel: 33-1-69-53-63-20
Fax: 33-1-69-30-90-79

Germany - Munich
Tel: 49-89-627-144-0
Fax: 49-89-627-144-44

Italy - Milan
Tel: 39-0331-742611
Fax: 39-0331-466781

Netherlands - Drunen
Tel: 31-416-690399
Fax: 31-416-690340

Spain - Madrid
Tel: 34-91-708-08-90
Fax: 34-91-708-08-91

UK - Wokingham
Tel: 44-118-921-5869
Fax: 44-118-921-5820

11/27/12



Компания «ЭлектроПласт» предлагает заключение долгосрочных отношений при поставках импортных электронных компонентов на взаимовыгодных условиях!

Наши преимущества:

- Оперативные поставки широкого спектра электронных компонентов отечественного и импортного производства напрямую от производителей и с крупнейших мировых складов;
- Поставка более 17-ти миллионов наименований электронных компонентов;
- Поставка сложных, дефицитных, либо снятых с производства позиций;
- Оперативные сроки поставки под заказ (от 5 рабочих дней);
- Экспресс доставка в любую точку России;
- Техническая поддержка проекта, помощь в подборе аналогов, поставка прототипов;
- Система менеджмента качества сертифицирована по Международному стандарту ISO 9001;
- Лицензия ФСБ на осуществление работ с использованием сведений, составляющих государственную тайну;
- Поставка специализированных компонентов (Xilinx, Altera, Analog Devices, Intersil, Interpoint, Microsemi, Aeroflex, Peregrine, Syfer, Eurofarad, Texas Instrument, Miteq, Cobham, E2V, MA-COM, Hittite, Mini-Circuits, General Dynamics и др.);

Помимо этого, одним из направлений компании «ЭлектроПласт» является направление «Источники питания». Мы предлагаем Вам помощь Конструкторского отдела:

- Подбор оптимального решения, техническое обоснование при выборе компонента;
- Подбор аналогов;
- Консультации по применению компонента;
- Поставка образцов и прототипов;
- Техническая поддержка проекта;
- Защита от снятия компонента с производства.



Как с нами связаться

Телефон: 8 (812) 309 58 32 (многоканальный)

Факс: 8 (812) 320-02-42

Электронная почта: org@eplast1.ru

Адрес: 198099, г. Санкт-Петербург, ул. Калинина, дом 2, корпус 4, литера А.