

Voltage-to-Frequency/Frequency-to-Voltage Converters

Features

VOLTAGE-TO-FREQUENCY

- Choice of Linearity
 - TC9401: 0.01%
 - TC9400: 0.05%
 - TC9402: 0.25%
- DC to 100kHz (F/V) or 1Hz to 100kHz (V/F)
- Low Power Dissipation: 27mW (Typ.)
- Single/Dual Supply Operation
 - +8V to +15V or $\pm 4V$ to $\pm 7.5V$
- Gain Temperature Stability: ± 25 ppm/ $^{\circ}C$ (Typ.)
- Programmable Scale Factor

FREQUENCY-TO-VOLTAGE

- Operation: DC to 100kHz
- Choice of Linearity
 - TC9401: 0.02%
 - TC9400: 0.05%
 - TC9402: 0.25%
- Programmable Scale Factor

Applications

- μP Data Acquisition
- 13-bit Analog-to-Digital Converters
- Analog Data Transmission and Recording
- Phase Locked Loops
- Frequency Meters/Tachometer
- Motor Control
- FM Demodulation

Device Selection Table

Part Number	Linearity (V/F)	Package	Temperature Range
TC9400COD	0.05%	14-Pin SOIC (Narrow)	0 $^{\circ}C$ to +70 $^{\circ}C$
TC9400CPD	0.05%	14-Pin PDIP	0 $^{\circ}C$ to +70 $^{\circ}C$
TC9400EJD	0.05%	14-Pin CerDIP	-40 $^{\circ}C$ to +85 $^{\circ}C$
TC9401CPD	0.01%	14-Pin PDIP	0 $^{\circ}C$ to +70 $^{\circ}C$
TC9401EJD	0.01%	14-Pin CerDIP	-40 $^{\circ}C$ to +85 $^{\circ}C$
TC9402CPD	0.25%	14-Pin PDIP	0 $^{\circ}C$ to +70 $^{\circ}C$
TC9402EJD	0.25%	14-Pin CerDIP	0 $^{\circ}C$ to +85 $^{\circ}C$

General Description

The TC9400/TC9401/TC9402 are low cost voltage-to-frequency (V/F) converters, utilizing low power CMOS technology. The converters accept a variable analog input signal and generate an output pulse train, whose frequency is linearly proportional to the input voltage.

The devices can also be used as highly accurate frequency-to-voltage (F/V) converters, accepting virtually any input frequency waveform and providing a linearly proportional voltage output.

A complete V/F or F/V system only requires the addition of two capacitors, three resistors, and reference voltage.

Package Type

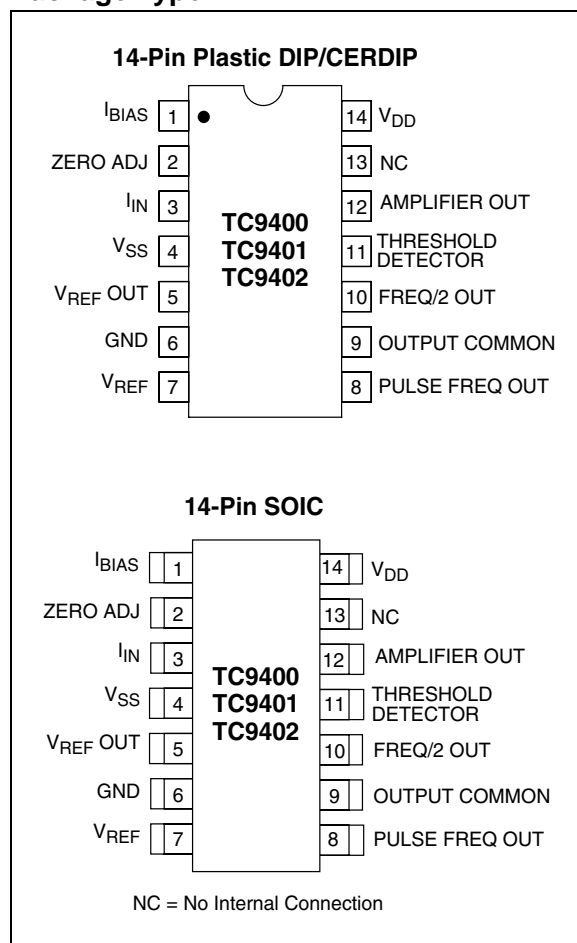

TC9400/9401/9402

Functional Block Diagram

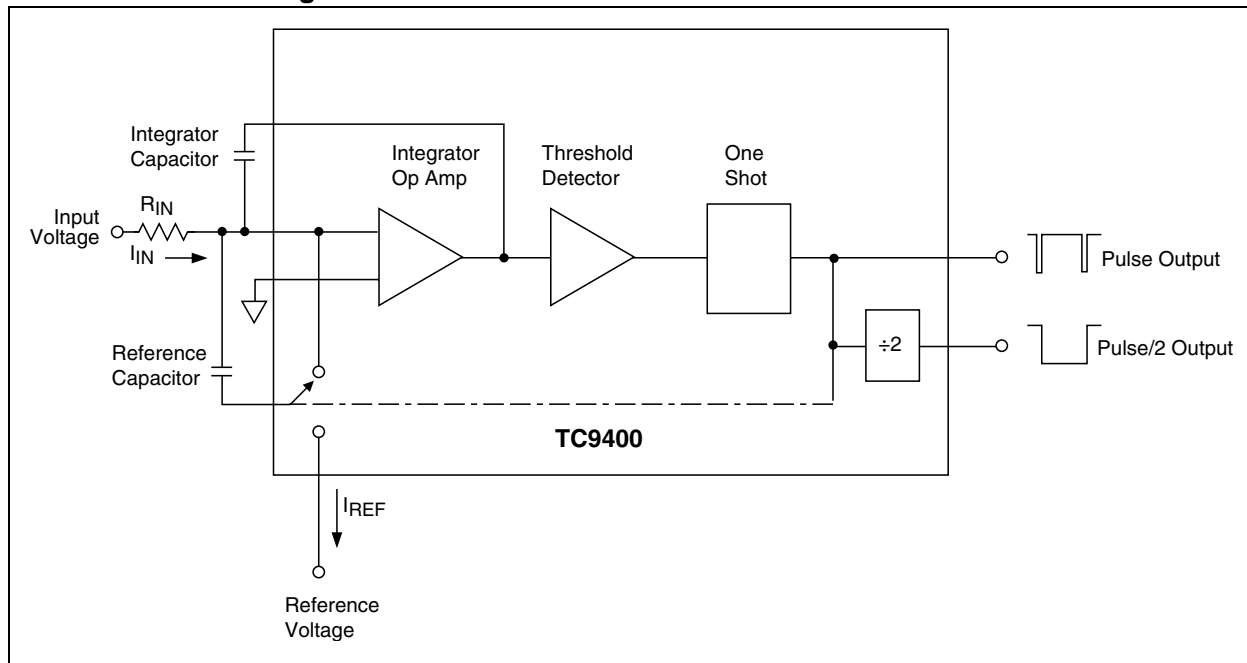

1.0 ELECTRICAL CHARACTERISTICS

Absolute Maximum Ratings*

$V_{DD} - V_{SS}$	+18V
I_{IN}	10mA
$V_{OUTMAX} - V_{OUT}$ Common.....	23V
$V_{REF} - V_{SS}$	-1.5V
Storage Temperature Range.....	-65°C to +150°C
Operating Temperature Range:	
C Device	0°C to +70°C
E Device.....	-40°C to +85°C
Package Dissipation ($T_A \leq 70^\circ\text{C}$):	
8-Pin CerDIP	800mW
8-Pin Plastic DIP	730mW
8-Pin SOIC	470mW

*Stresses above those listed under "Absolute Maximum Ratings" may cause permanent damage to the device. These are stress ratings only and functional operation of the device at these or any other conditions above those indicated in the operation sections of the specifications is not implied. Exposure to Absolute Maximum Rating conditions for extended periods may affect device reliability.

TC940X ELECTRICAL SPECIFICATIONS

Electrical Characteristics: $V_{DD} = +5V$, $V_{SS} = -5V$, $V_{GND} = 0V$, $V_{REF} = -5V$, $R_{BIAS} = 100k\Omega$, Full Scale = 10kHz, unless otherwise specified. $T_A = +25^\circ\text{C}$, unless temperature range is specified (-40°C to +85°C for E device, 0°C to +70°C for C device).											
Parameter	Min	Typ	Max	Min	Typ	Max	Min	Typ	Max	Units	Test Conditions
Voltage-to-Frequency											
Accuracy	TC9400			TC9401			TC9402				
Linearity 10kHz	—	0.01	0.05	—	0.004	0.01	—	0.05	0.25	% Full Scale	Output Deviation from Straight Line Between Normalized Zero and Full Scale Input
Linearity 100kHz	—	0.1	0.25	—	0.04	0.08	—	0.25	0.5	% Full Scale	Output Deviation from Straight Line Between Normalized Zero Reading and Full Scale Input
Gain Temperature Drift (Note 1)	—	±25	±40	—	±25	±40	—	±50	±100	ppm/°C Full Scale	Variation in Gain A due to Temperature Change
Gain Variance	—	±10	—	—	±10	—	—	±10	—	% of Nominal	Variation from Ideal Accuracy
Zero Offset (Note 2)	—	±10	±50	—	±10	±50	—	±20	±100	mV	Correction at Zero Adjust for Zero Output when Input is Zero
Zero Temperature Drift (Note 1)	—	±25	±50	—	±25	±50	—	±50	±100	µV/°C	Variation in Zero Offset Due to Temperature Change

- Note** 1: Full temperature range; not tested.
 2: $I_{IN} = 0$.
 3: Full temperature range, $I_{OUT} = 10\text{mA}$.
 4: $I_{OUT} = 10\mu\text{A}$.
 5: Threshold Detect = 5V, Amp Out = 0V, full temperature range.
 6: 10Hz to 100kHz; not tested.
 7: 5µsec minimum positive pulse width and 0.5µsec minimum negative pulse width.
 8: $t_R = t_F = 20\text{nsec}$.
 9: $R_L \geq 2k\Omega$, tested @ 10kΩ.
 10: Full temperature range, $V_{IN} = -0.1V$.

TC9400/9401/9402

TC940X ELECTRICAL SPECIFICATIONS (CONTINUED)

Electrical Characteristics: $V_{DD} = +5V$, $V_{SS} = -5V$, $V_{GND} = 0V$, $V_{REF} = -5V$, $R_{BIAS} = 100k\Omega$, Full Scale = 10kHz, unless otherwise specified. $T_A = +25^\circ C$, unless temperature range is specified ($-40^\circ C$ to $+85^\circ C$ for E device, $0^\circ C$ to $+70^\circ C$ for C device).											
Parameter	Min	Typ	Max	Min	Typ	Max	Min	Typ	Max	Units	Test Conditions
Analog Input											
I_{IN} Full Scale	—	10	—	—	10	—	—	10	—	μA	Full Scale Analog Input Current to achieve Specified Accuracy
I_{IN} Over Range	—	—	50	—	—	50	—	—	50	μA	Over Range Current
Response Time	—	2	—	—	2	—	—	2	—	Cycle	Settling Time to 0.1% Full Scale
Digital Section	TC9400			TC9401			TC9402				
V_{SAT} @ $I_{OL} = 10mA$	—	0.2	0.4	—	0.2	0.4	—	0.2	0.4	V	Logic "0" Output Voltage (Note 3)
$V_{OUTMAX} - V_{OUT}$ Common (Note 4)	—	—	18	—	—	18	—	—	18	V	Voltage Range Between Output and Common
Pulse Frequency Output Width	—	3	—	—	3	—	—	3	—	μsec	
Frequency-to-Voltage											
Supply Current											
I_{DD} Quiescent (Note 5)	—	1.5	6	—	1.5	6	—	3	10	mA	Current Required from Positive Supply during Operation
I_{SS} Quiescent (Note 5)	—	-1.5	-6	—	-1.5	-6	—	-3	-10	mA	Current Required from Negative Supply during Operation
V_{DD} Supply	4	—	7.5	4	—	7.5	4	—	7.5	V	Operating Range of Positive Supply
V_{SS} Supply	-4	—	-7.5	-4	—	-7.5	-4	—	-7.5	V	Operating Range of Negative Supply
Reference Voltage											
$V_{REF} - V_{SS}$	-2.5	—	—	-2.5	—	—	-2.5	—	—	V	Range of Voltage Reference Input
Accuracy											
Non-Linearity (Note 10)	—	0.02	0.05	—	0.01	0.02	—	0.05	0.25	% Full Scale	Deviation from ideal Transfer Function as a Percentage Full Scale Voltage
Input Frequency Range (Notes 7 and 8)	10	—	100k	10	—	100k	10	—	100k	Hz	Frequency Range for Specified Non-Linearity

- Note** 1: Full temperature range; not tested.
 2: $I_{IN} = 0$.
 3: Full temperature range, $I_{OUT} = 10mA$.
 4: $I_{OUT} = 10\mu A$.
 5: Threshold Detect = 5V, Amp Out = 0V, full temperature range.
 6: 10Hz to 100kHz; not tested.
 7: 5 μsec minimum positive pulse width and 0.5 μsec minimum negative pulse width.
 8: $t_R = t_F = 20nsec$.
 9: $R_L \geq 2k\Omega$, tested @ 10k Ω .
 10: Full temperature range, $V_{IN} = -0.1V$.

TC940X ELECTRICAL SPECIFICATIONS (CONTINUED)

Electrical Characteristics: $V_{DD} = +5V$, $V_{SS} = -5V$, $V_{GND} = 0V$, $V_{REF} = -5V$, $R_{BIAS} = 100k\Omega$, Full Scale = 10kHz, unless otherwise specified. $T_A = +25^\circ C$, unless temperature range is specified ($-40^\circ C$ to $+85^\circ C$ for E device, $0^\circ C$ to $+70^\circ C$ for C device).

Parameter	Min	Typ	Max	Min	Typ	Max	Min	Typ	Max	Units	Test Conditions
Frequency Input											
Positive Excursion	0.4	—	V_{DD}	0.4	—	V_{DD}	0.4	—	V_{DD}	V	Voltage Required to Turn Threshold Detector On
Negative Excursion	-0.4	—	-2	-0.4	—	-2	-0.4	—	-2	V	Voltage Required to Turn Threshold Detector Off
Minimum Positive Pulse Width (Note 8)	—	5	—	—	5	—	—	5	—	μsec	Time between Threshold Crossings
Minimum Negative Pulse Width (Note 8)	—	0.5	—	—	0.5	—	—	0.5	—	μsec	Time Between Threshold Crossings
Input Impedance	—	10	—	—	10	—	—	—	10	$M\Omega$	
Analog Outputs	TC9400			TC9401			TC9402				
Output Voltage (Note 9)	—	$V_{DD} - 1$	—	—	$V_{DD} - 1$	—	—	$V_{DD} - 1$	—	V	Voltage Range of Op Amp Output for Specified Non-Linearity
Output Loading	2	—	—	2	—	—	2	—	—	$k\Omega$	Resistive Loading at Output of Op Amp
Supply Current	TC9400			TC9401			TC9402				
I_{DD} Quiescent (Note 10)	—	1.5	6	—	1.5	6	—	3	10	mA	Current Required from Positive Supply During Operation
I_{SS} Quiescent (Note 10)	—	-1.5	-6	—	-1.5	-6	—	-3	-10	mA	Current Required from Negative Supply During Operation
V_{DD} Supply	4	—	7.5	4	—	7.5	4	—	7.5	V	Operating Range of Positive Supply
V_{SS} Supply	-4	—	-7.5	-4	—	-7.5	-4	—	-7.5	V	Operating Range of Negative Supply
Reference Voltage											
$V_{REF} - V_{SS}$	-2.5	—	—	-2.5	—	—	-2.5	—	—	V	Range of Voltage Reference Input

- Note**
- 1: Full temperature range; not tested.
 - 2: $I_{IN} = 0$.
 - 3: Full temperature range, $I_{OUT} = 10mA$.
 - 4: $I_{OUT} = 10\mu A$.
 - 5: Threshold Detect = 5V, Amp Out = 0V, full temperature range.
 - 6: 10Hz to 100kHz; not tested.
 - 7: $5\mu sec$ minimum positive pulse width and $0.5\mu sec$ minimum negative pulse width.
 - 8: $t_R = t_F = 20nsec$.
 - 9: $R_L \geq 2k\Omega$, tested @ 10k Ω .
 - 10: Full temperature range, $V_{IN} = -0.1V$.

TC9400/9401/9402

2.0 PIN DESCRIPTIONS

The descriptions of the pins are listed in Table 2-1.

TABLE 2-1: PIN FUNCTION TABLE

Pin No. 14-Pin PDIP/CERDIP 14-Pin SOIC (Narrow)	Symbol	Description
1	I_{BIAS}	This pin sets bias current in the TC9400. Connect to V_{SS} through a 100k Ω resistor.
2	ZERO ADJ	Low frequency adjustment input.
3	I_{IN}	Input current connection for the V/F converter.
4	V_{SS}	Negative power supply voltage connection, typically -5V.
5	V_{REF} OUT	Reference capacitor connection.
6	GND	Analog ground.
7	V_{REF}	Voltage reference input, typically -5V.
8	PULSE FREQ OUT	Frequency output. This open drain output will pulse LOW each time the Freq. Threshold Detector limit is reached. The pulse rate is proportional to input voltage.
9	OUTPUT COMMON	Source connection for the open drain output FETs.
10	FREQ/2 OUT	This open drain output is a square wave at one-half the frequency of the pulse output (Pin 8). Output transitions of this pin occur on the rising edge of Pin 8.
11	THRESHOLD DETECTOR	Input to the Threshold Detector. This pin is the frequency input during F/V operation.
12	AMPLIFIER OUT	Output of the integrator amplifier.
13	NC	No internal connection.
14	V_{DD}	Positive power supply connection, typically +5V.

3.0 DETAILED DESCRIPTION

3.1 Voltage-to-Frequency (V/F) Circuit Description

The TC9400 V/F converter operates on the principal of charge balancing. The operation of the TC9400 is easily understood by referring to Figure 3-1. The input voltage (V_{IN}) is converted to a current (I_{IN}) by the input resistor. This current is then converted to a charge on the integrating capacitor and shows up as a linearly decreasing voltage at the output of the Op Amp. The lower limit of the output swing is set by the threshold detector, which causes the reference voltage to be applied to the reference capacitor for a time period long enough to charge the capacitor to the reference voltage. This action reduces the charge on the integrating capacitor by a fixed amount ($q = C_{REF} \times V_{REF}$), causing the Op Amp output to step up a finite amount.

At the end of the charging period, C_{REF} is shorted out. This dissipates the charge stored on the reference capacitor, so that when the output again crosses zero, the system is ready to recycle. In this manner, the continued discharging of the integrating capacitor by the

input is balanced out by fixed charges from the reference voltage. As the input voltage is increased, the number of reference pulses required to maintain balance increases, which causes the output frequency to also increase. Since each charge increment is fixed, the increase in frequency with voltage is linear. In addition, the accuracy of the output pulse width does not directly affect the linearity of the V/F. The pulse must simply be long enough for full charge transfer to take place.

The TC9400 contains a "self-start" circuit to ensure the V/F converter always operates properly when power is first applied. In the event that, during power-on, the Op Amp output is below the threshold and C_{REF} is already charged, a positive voltage step will not occur. The Op Amp output will continue to decrease until it crosses the -3.0V threshold of the "self-start" comparator. When this happens, an internal resistor is connected to the Op Amp input, which forces the output to go positive until the TC9400 is in its Normal Operating mode.

The TC9400 utilizes low power CMOS processing for low input bias and offset currents, with very low power dissipation. The open drain N-channel output FETs provide high voltage and high current sink capability.

FIGURE 3-1: 10Hz TO 10kHz V/F CONVERTER

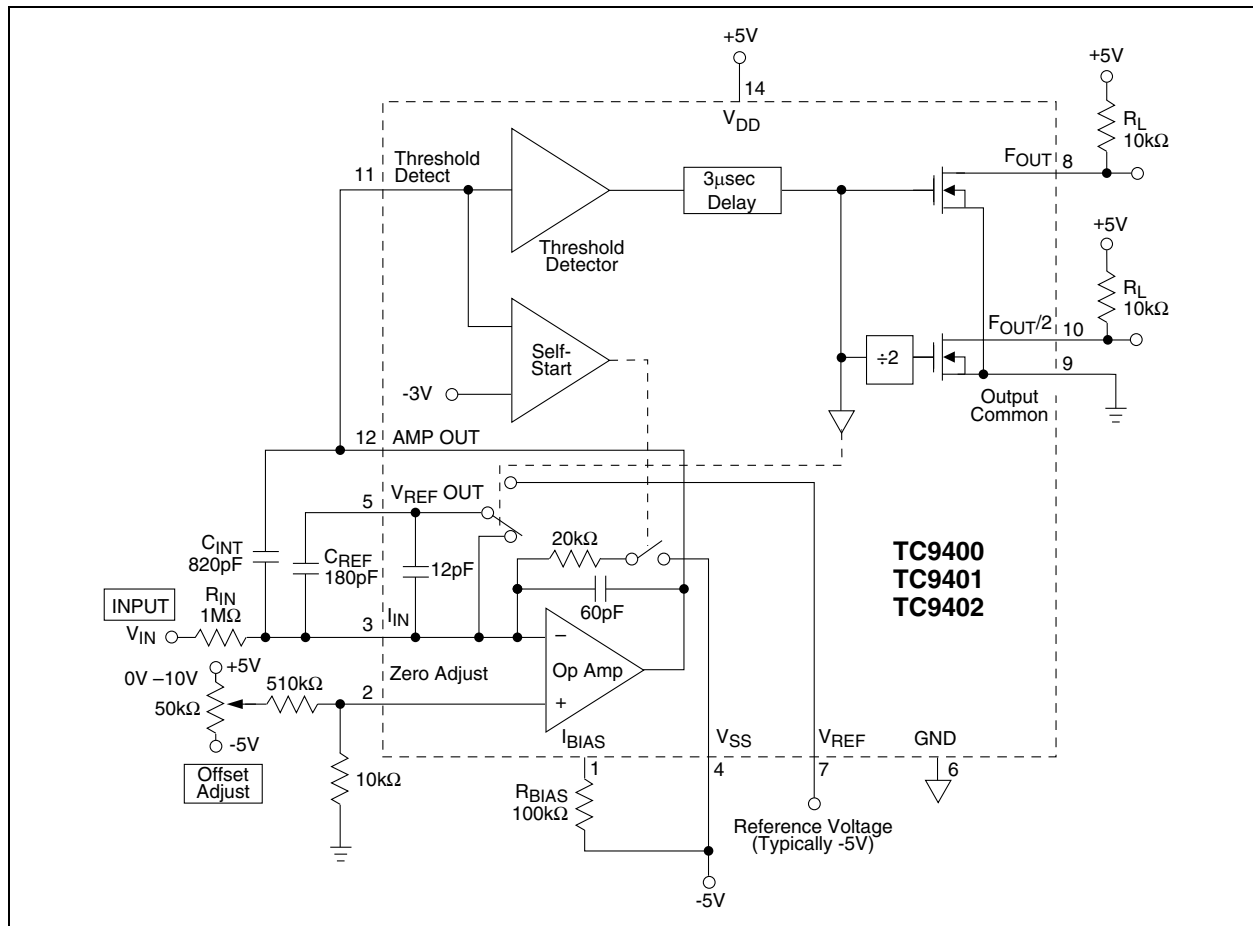

TC9400/9401/9402

3.2 Voltage-to-Time Measurements

The TC9400 output can be measured in the time domain as well as the frequency domain. Some microcomputers, for example, have extensive timing capability, but limited counter capability. Also, the response time of a time domain measurement is only the period between two output pulses, while the frequency measurement must accumulate pulses during the entire counter time-base period.

Time measurements can be made from either the TC9400's PULSE FREQ OUT output, or from the FREQ/2 OUT output. The FREQ/2 OUT output changes state on the rising edge of PULSE FREQ OUT, so FREQ/2 OUT is a symmetrical square wave at one-half the pulse output frequency. Timing measurements can, therefore, be made between successive PULSE FREQ OUT pulses, or while FREQ/2 OUT is high (or low).

4.0 PIN FUNCTIONS

4.1 Threshold Detector Input

In the V/F mode, this input is connected to the AMPLIFIER OUT output (Pin 12) and triggers a 3 μ sec pulse when the input voltage passes through its threshold. In the F/V mode, the input frequency is applied to this input.

The nominal threshold of the detector is half way between the power supplies, or $(V_{DD} + V_{SS})/2 \pm 400\text{mV}$. The TC9400's charge balancing V/F technique is not dependent on a precision comparator threshold, because the threshold only sets the lower limit of the Op Amp output. The Op Amp's peak-to-peak output swing, which determines the frequency, is only influenced by external capacitors and by V_{REF} .

4.2 Pulse Freq Out

This output is an open drain N-channel FET, which provides a pulse waveform whose frequency is proportional to the input voltage. This output requires a pull-up resistor and interfaces directly with MOS, CMOS, and TTL logic (see Figure 4-1).

FIGURE 4-1: OUTPUT WAVEFORMS

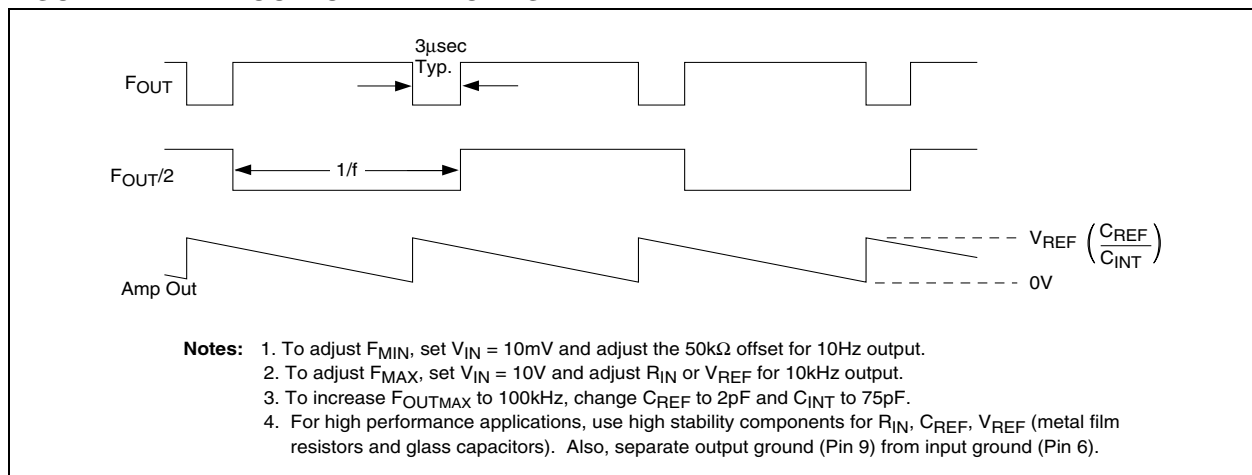

4.3 Freq/2 Out

This output is an open drain N-channel FET, which provides a square wave one-half the frequency of the pulse frequency output. The FREQ/2 OUT output will change state on the rising edge of PULSE FREQ OUT. This output requires a pull-up resistor and interfaces directly with MOS, CMOS, and TTL logic.

4.4 Output Common

The sources of both the FREQ/2 OUT and the PULSE FREQ OUT are connected to this pin. An output level swing from the drain voltage to ground, or to the V_{SS} supply, may be obtained by connecting this pin to the appropriate point.

4.5 R_{BIAS}

An external resistor, connected to V_{SS} , sets the bias point for the TC9400. Specifications for the TC9400 are based on $R_{BIAS} = 100k\Omega \pm 10\%$, unless otherwise noted.

Increasing the maximum frequency of the TC9400 beyond 100kHz is limited by the pulse width of the pulse output (typically 3 μ sec). Reducing R_{BIAS} will decrease the pulse width and increase the maximum operating frequency, but linearity errors will also increase. R_{BIAS} can be reduced to 20k Ω , which will typically produce a maximum full scale frequency of 500kHz.

4.6 Amplifier Out

This pin is the output stage of the operational amplifier. During V/F operation, a negative going ramp signal is available at this pin. In the F/V mode, a voltage proportional to the frequency input is generated.

4.7 Zero Adjust

This pin is the non-inverting input of the operational amplifier. The low frequency set point is determined by adjusting the voltage at this pin.

4.8 I_{IN}

The inverting input of the operational amplifier and the summing junction when connected in the V/F mode. An input current of 10 μ A is specified, but an over range current up to 50 μ A can be used without detrimental effect to the circuit operation. I_{IN} connects the summing junction of an operational amplifier. Voltage sources cannot be attached directly, but must be buffered by external resistors.

4.9 V_{REF}

A reference voltage from either a precision source, or the V_{SS} supply is applied to this pin. Accuracy of the TC9400 is dependent on the voltage regulation and temperature characteristics of the reference circuitry.

Since the TC9400 is a charge balancing V/F converter, the reference current will be equal to the input current. For this reason, the DC impedance of the reference voltage source must be kept low enough to prevent linearity errors. For linearity of 0.01%, a reference impedance of 200W or less is recommended. A 0.1 μ F bypass capacitor should be connected from V_{REF} to ground.

4.10 V_{REF} Out

The charging current for C_{REF} is supplied through this pin. When the Op Amp output reaches the threshold level, this pin is internally connected to the reference voltage and a charge, equal to $V_{REF} \times C_{REF}$, is removed from the integrator capacitor. After about 3 μ sec, this pin is internally connected to the summing junction of the Op Amp to discharge C_{REF} . Break-before-make switching ensures that the reference voltage is not directly applied to the summing junction.

TC9400/9401/9402

5.0 VOLTAGE-TO-FREQUENCY (V/F) CONVERTER DESIGN INFORMATION

5.1 Input/Output Relationships

The output frequency (F_{OUT}) is related to the analog input voltage (V_{IN}) by the transfer equation:

EQUATION 5-1:

$$\text{Frequency Out} = \frac{V_{IN}}{R_{IN}} \times \frac{1}{(V_{REF})(V_{REF})}$$

5.2 External Component Selection

5.2.1 R_{IN}

The value of this component is chosen to give a full scale input current of approximately $10\mu\text{A}$:

EQUATION 5-2:

$$R_{IN} \cong \frac{V_{IN \text{ FULLSCALE}}}{10\mu\text{A}}$$

EQUATION 5-3:

$$R_{IN} \cong \frac{10\text{V}}{10\mu\text{A}} = 1\text{M}\Omega$$

Note that the value is an approximation and the exact relationship is defined by the transfer equation. In practice, the value of R_{IN} typically would be trimmed to obtain full scale frequency at V_{IN} full scale (see Section 5.3, Adjustment Procedure). Metal film resistors with 1% tolerance or better are recommended for high accuracy applications because of their thermal stability and low noise generation.

5.2.2 C_{INT}

The exact value is not critical but is related to C_{REF} by the relationship:

$$3C_{REF} \leq C_{INT} \leq 10C_{REF}$$

Improved stability and linearity are obtained when $C_{INT} \leq 4C_{REF}$. Low leakage types are recommended, although mica and ceramic devices can be used in applications where their temperature limits are not exceeded. Locate as close as possible to Pins 12 and 13.

5.2.3 C_{REF}

The exact value is not critical and may be used to trim the full scale frequency (see Section 7.1, Input/Output Relationships). Glass film or air trimmer capacitors are recommended because of their stability and low leakage. Locate as close as possible to Pins 5 and 3 (see Figure 5-1).

FIGURE 5-1: RECOMMENDED C_{REF} VS. V_{REF}

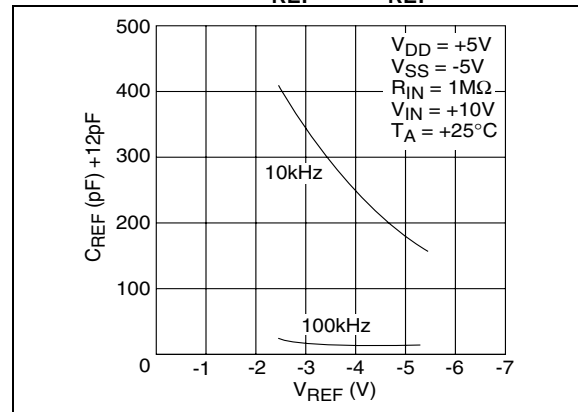

5.2.4 V_{DD} , V_{SS}

Power supplies of $\pm 5\text{V}$ are recommended. For high accuracy requirements, 0.05% line and load regulation and $0.1\mu\text{F}$ disc decoupling capacitors, located near the pins, are recommended.

5.3 Adjustment Procedure

Figure 3-1 shows a circuit for trimming the zero location. Full scale may be trimmed by adjusting R_{IN} , V_{REF} , or C_{REF} . Recommended procedure for a 10kHz full scale frequency is as follows:

1. Set V_{IN} to 10mV and trim the zero adjust circuit to obtain a 10Hz output frequency.
2. Set V_{IN} to 10V and trim either R_{IN} , V_{REF} , or C_{REF} to obtain a 10kHz output frequency.

If adjustments are performed in this order, there should be no interaction and they should not have to be repeated.

5.4 Improved Single Supply V/F Converter Operation

A TC9400, which operates from a single 12 to 15V variable power source, is shown in Figure 5-2. This circuit uses two Zener diodes to set stable biasing levels for the TC9400. The Zener diodes also provide the reference voltage, so the output impedance and temperature coefficient of the Zeners will directly affect power supply rejection and temperature performance. Full scale adjustment is accomplished by trimming the input current. Trimming the reference voltage is not recommended for high accuracy applications unless an Op Amp is used as a buffer, because the TC9400 requires a low impedance reference (see Section 4.9, V_{REF} pin description, for more information).

The circuit of Figure 5-2 will directly interface with CMOS logic operating at 12V to 15V. TTL or 5V CMOS logic can be accommodated by connecting the output pull-up resistors to the +5V supply. An optoisolator can also be used if an isolated output is required; also, see Figure 5-3.

TC9400/9401/9402

6.0 FREQUENCY-TO-VOLTAGE (F/V) CIRCUIT DESCRIPTION

When used as an F/V converter, the TC9400 generates an output voltage linearly proportional to the input frequency waveform.

Each zero crossing at the threshold detector's input causes a precise amount of charge ($q = C_{REF} \times V_{REF}$) to be dispensed into the Op Amp's summing junction. This charge, in turn, flows through the feedback resistor, generating voltage pulses at the output of the Op Amp. A capacitor (C_{INT}) across R_{INT} averages these pulses into a DC voltage, which is linearly proportional to the input frequency.

7.0 F/V CONVERTER DESIGN INFORMATION

7.1 Input/Output Relationships

The output voltage is related to the input frequency (F_{IN}) by the transfer equation:

EQUATION 7-1:

$$V_{OUT} = [V_{REF} C_{REF} R_{INT}] F_{IN}$$

The response time to a change in F_{IN} is equal to $(R_{INT} C_{INT})$. The amount of ripple on V_{OUT} is inversely proportional to C_{INT} and the input frequency.

C_{INT} can be increased to lower the ripple. Values of $1\mu\text{F}$ to $100\mu\text{F}$ are perfectly acceptable for low frequencies.

When the TC9400 is used in the Single Supply mode, V_{REF} is defined as the voltage difference between Pin 7 and Pin 2.

7.2 Input Voltage Levels

The input frequency is applied to the Threshold Detector input (Pin 11). As discussed in the V/F circuit section of this data sheet, the threshold of Pin 11 is approximately $(V_{DD} + V_{SS})/2 \pm 400\text{mV}$. Pin 11's input voltage range extends from V_{DD} to about 2.5V below the threshold. If the voltage on Pin 11 goes more than 2.5 volts below the threshold, the V/F mode start-up comparator will turn on and corrupt the output voltage. The Threshold Detector input has about 200mV of hysteresis.

In $\pm 5\text{V}$ applications, the input voltage levels for the TC9400 are $\pm 400\text{mV}$, minimum. If the frequency source being measured is unipolar, such as TTL or CMOS operating from a +5V source, then an AC coupled level shifter should be used. One such circuit is shown in Figure 7-1(a).

The level shifter circuit in Figure 7-1(b) can be used in single supply F/V applications. The resistor divider ensures that the input threshold will track the supply voltages. The diode clamp prevents the input from going far enough in the negative direction to turn on the start-up comparator. The diode's forward voltage decreases by $2.1\text{mV}/^\circ\text{C}$, so for high ambient temperature operation, two diodes in series are recommended; also, see Figure 7-2.

FIGURE 7-1: FREQUENCY INPUT LEVEL SHIFTER

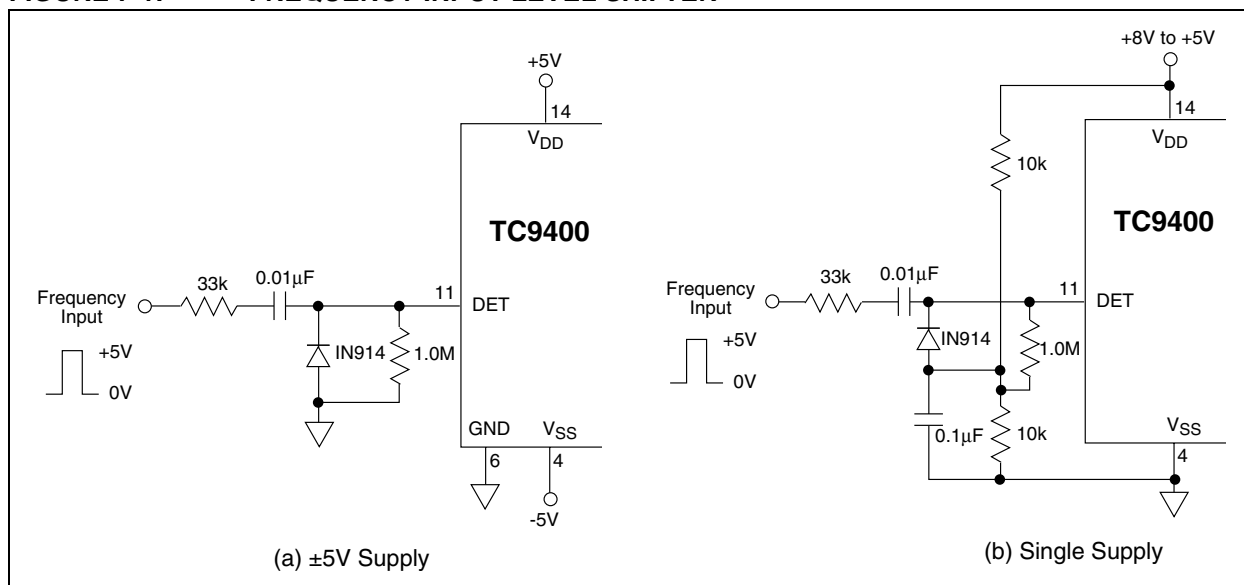
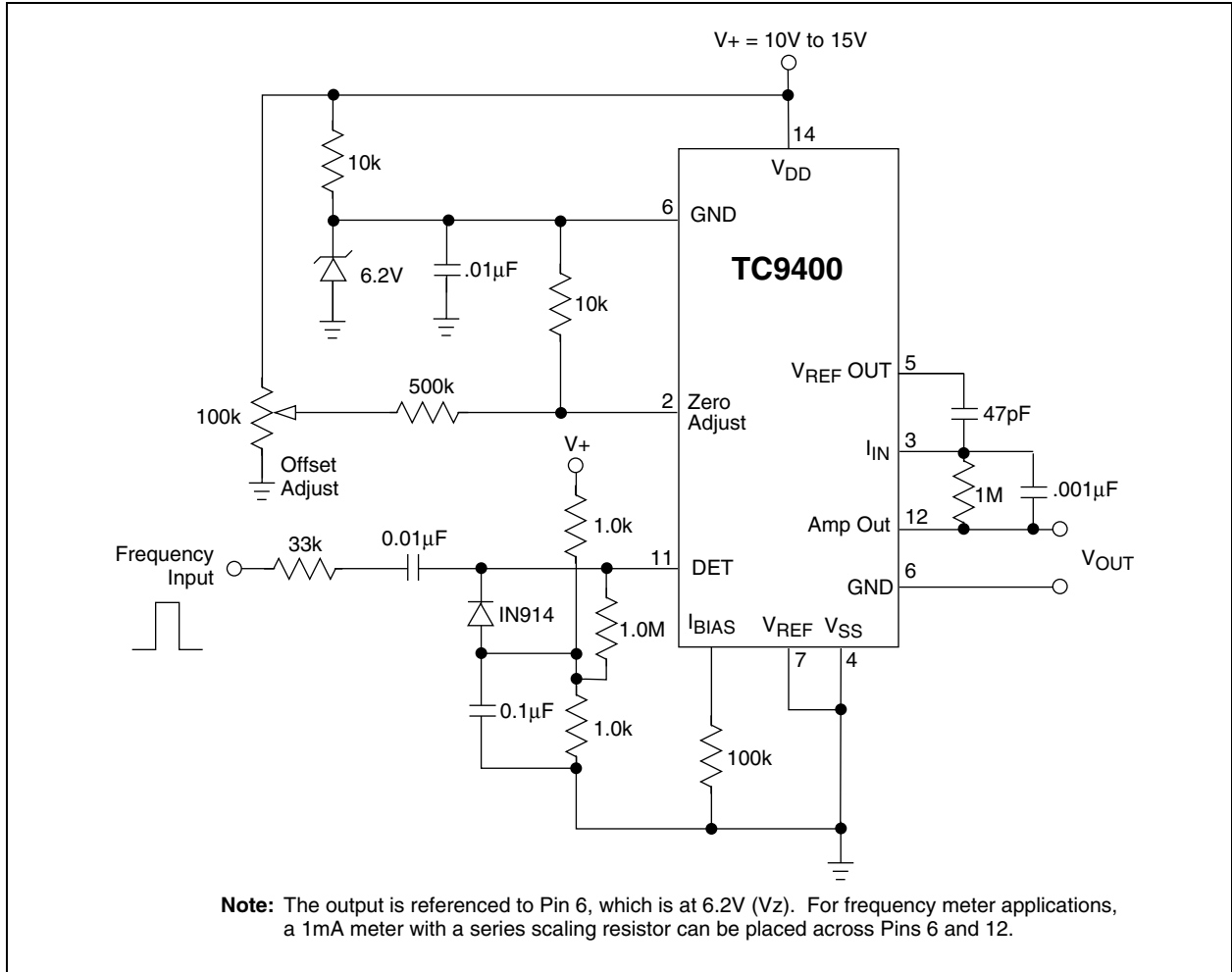

FIGURE 7-2: F/V SINGLE SUPPLY F/V CONVERTER



7.3 Input Buffer

F_{OUT} and $F_{OUT}/2$ are not used in the F/V mode. However, these outputs may be useful for some applications, such as a buffer to feed additional circuitry. Then, F_{OUT} will follow the input frequency waveform, except that F_{OUT} will go high 3µsec after F_{IN} goes high; $F_{OUT}/2$ will be square wave with a frequency of one-half F_{OUT} .

If these outputs are not used, Pins 8, 9 and 10 should be connected to ground (see Figure 7-3 and Figure 7-4).

FIGURE 7-3: F/V DIGITAL OUTPUTS

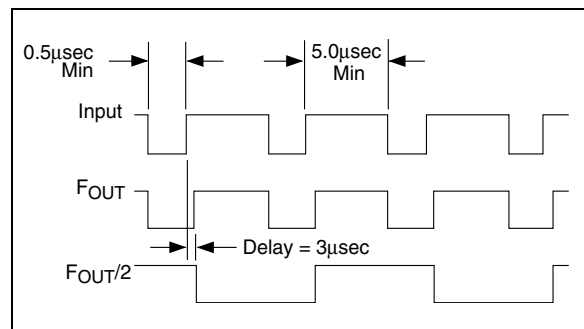

8.0 F/V POWER-ON RESET

In F/V mode, the TC9400 output voltage will occasionally be at its maximum value when power is first applied. This condition remains until the first pulse is applied to F_{IN} . In most frequency measurement applications, this is not a problem because proper operation begins as soon as the frequency input is applied.

In some cases, however, the TC9400 output must be zero at power-on without a frequency input. In such cases, a capacitor connected from Pin 11 to V_{DD} will usually be sufficient to pulse the TC9400 and provide a Power-on Reset (see Figure 8-1 (a) and (b)). Where predictable power-on operation is critical, a more complicated circuit, such as Figure 8-1 (b), may be required.

FIGURE 8-1: POWER-ON OPERATION/RESET

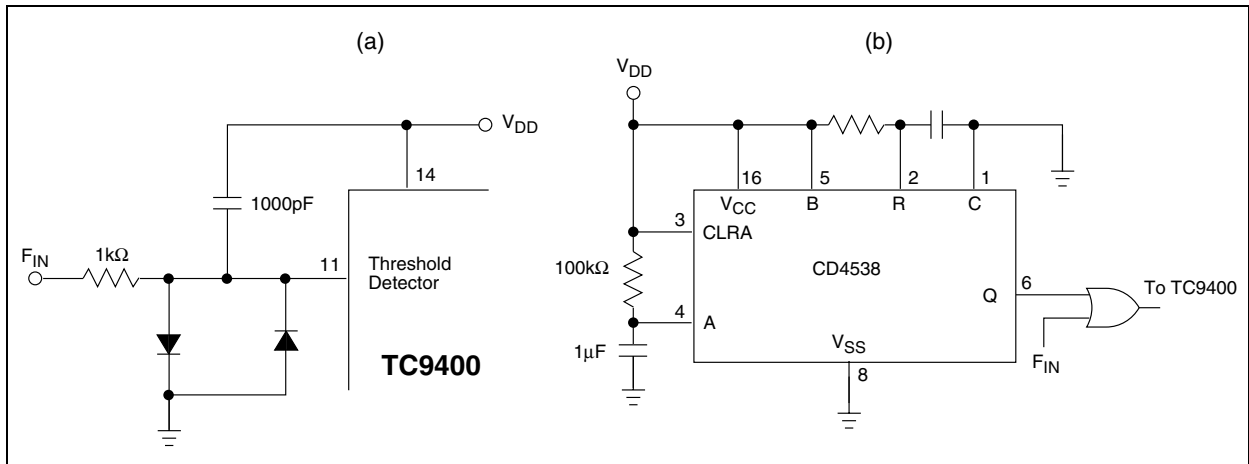

TC9400/9401/9402

9.0 PACKAGE INFORMATION

9.1 Package Marking Information

Package marking data is not available at this time.

9.2 Taping Form

Component Taping Orientation for 14-Pin SOIC (Narrow) Devices

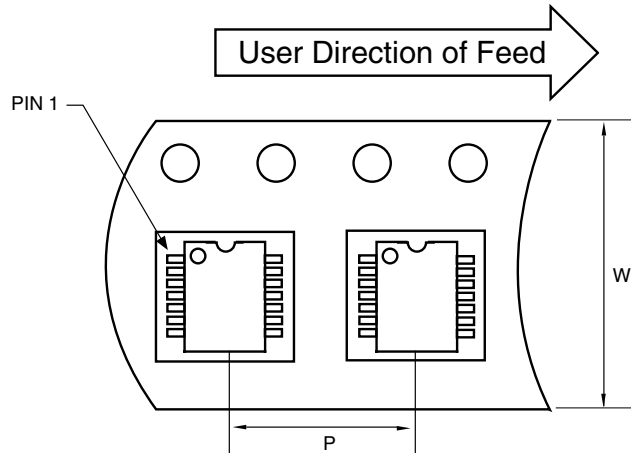

Standard Reel Component Orientation
for TR Suffix Device

Carrier Tape, Reel Size, and Number of Components Per Reel

Package	Carrier Width (W)	Pitch (P)	Part Per Full Reel	Reel Size
14-Pin SOIC (N)	12 mm	8 mm	2500	13 in

9.3 Package Dimensions

14-Pin CDIP (Narrow)

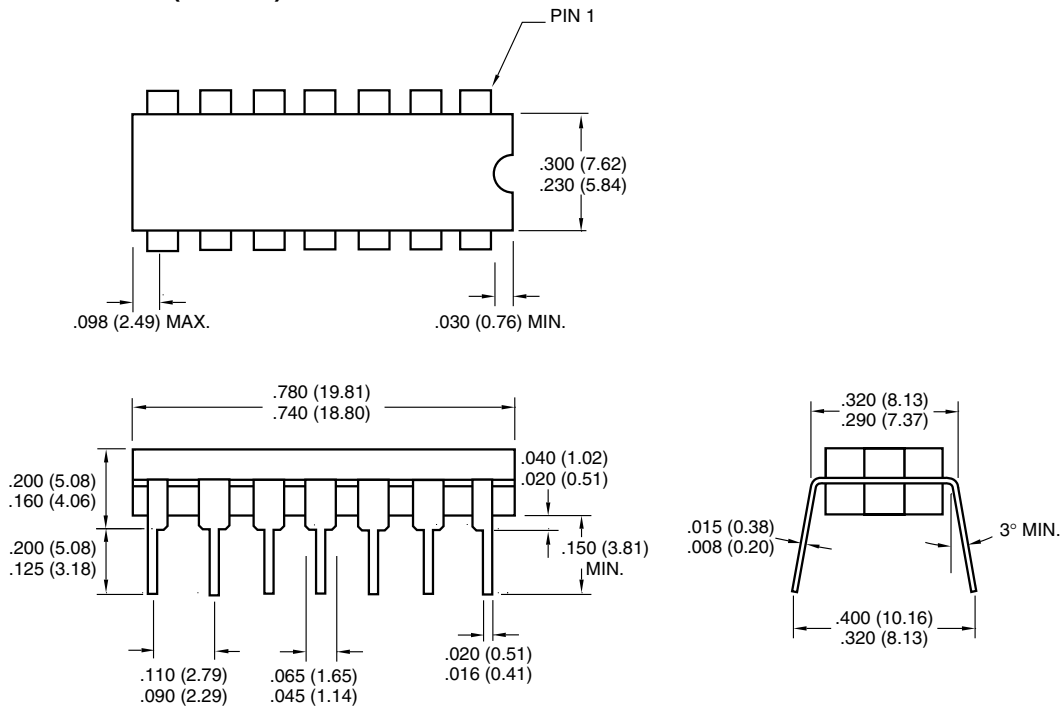

Dimensions: inches (mm)

9.3 Package Dimensions (Continued)

14-Pin PDIP (Narrow)

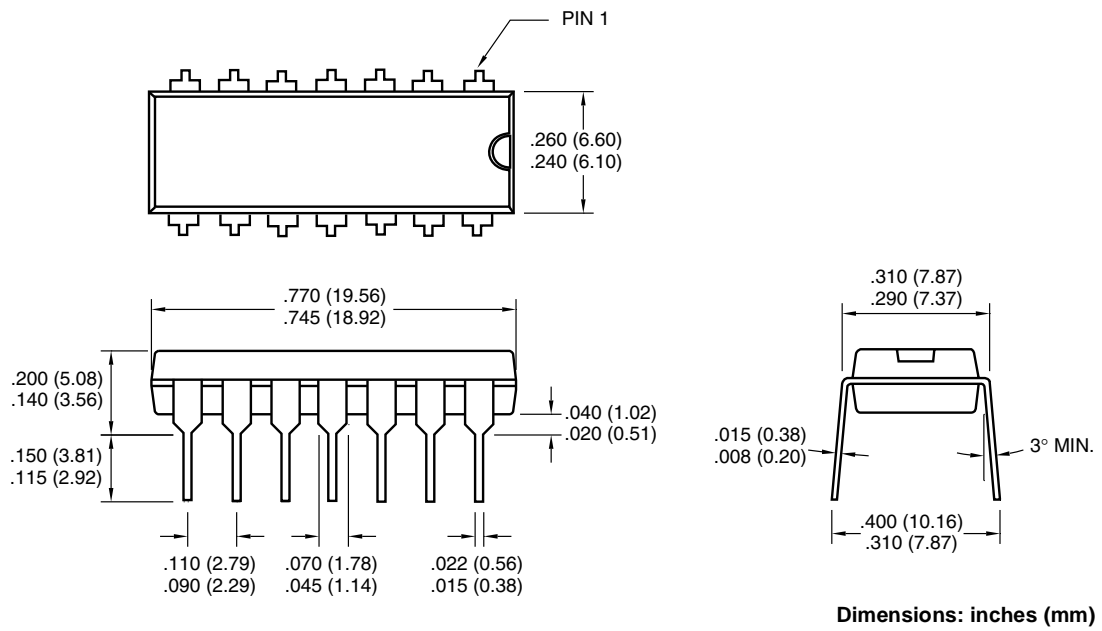

14-Pin SOIC (Narrow)

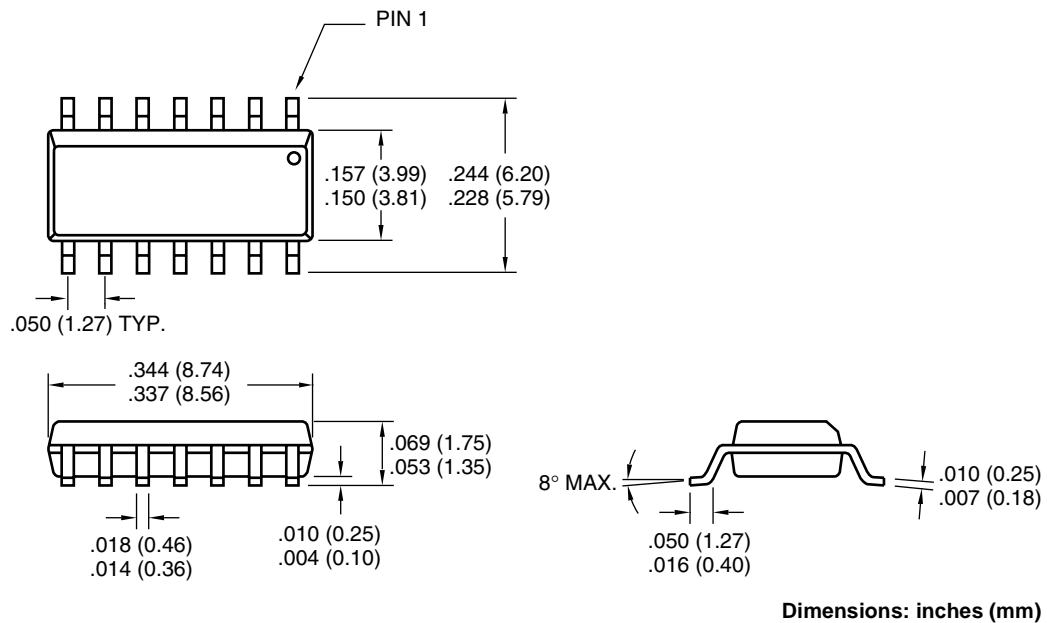

SALES AND SUPPORT

Data Sheets

Products supported by a preliminary Data Sheet may have an errata sheet describing minor operational differences and recommended workarounds. To determine if an errata sheet exists for a particular device, please contact one of the following:

1. Your local Microchip sales office
2. The Microchip Corporate Literature Center U.S. FAX: (480) 792-7277
3. The Microchip Worldwide Site (www.microchip.com)

Please specify which device, revision of silicon and Data Sheet (include Literature #) you are using.

New Customer Notification System

Register on our web site (www.microchip.com/cn) to receive the most current information on our products.

Information contained in this publication regarding device applications and the like is intended through suggestion only and may be superseded by updates. It is your responsibility to ensure that your application meets with your specifications. No representation or warranty is given and no liability is assumed by Microchip Technology Incorporated with respect to the accuracy or use of such information, or infringement of patents or other intellectual property rights arising from such use or otherwise. Use of Microchip's products as critical components in life support systems is not authorized except with express written approval by Microchip. No licenses are conveyed, implicitly or otherwise, under any intellectual property rights.

Trademarks

The Microchip name and logo, the Microchip logo, FilterLab, KEELOQ, microID, MPLAB, PIC, PICmicro, PICMASTER, PICSTART, PRO MATE, SEEVAL and The Embedded Control Solutions Company are registered trademarks of Microchip Technology Incorporated in the U.S.A. and other countries.

dsPIC, ECONOMONITOR, FanSense, FlexROM, fuzzyLAB, In-Circuit Serial Programming, ICSP, ICEPIC, microPort, Migratable Memory, MPASM, MPLIB, MPLINK, MPSIM, MXDEV, PICC, PICDEM, PICDEM.net, rfPIC, Select Mode and Total Endurance are trademarks of Microchip Technology Incorporated in the U.S.A.

Serialized Quick Turn Programming (SQTP) is a service mark of Microchip Technology Incorporated in the U.S.A.

All other trademarks mentioned herein are property of their respective companies.

© 2002, Microchip Technology Incorporated, Printed in the U.S.A., All Rights Reserved.

 Printed on recycled paper.

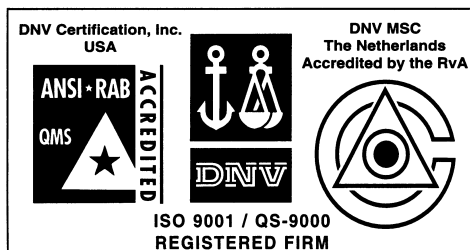

Microchip received QS-9000 quality system certification for its worldwide headquarters, design and wafer fabrication facilities in Chandler and Tempe, Arizona in July 1999 and Mountain View, California in March 2002. The Company's quality system processes and procedures are QS-9000 compliant for its PICmicro® 8-bit MCUs, KEELOQ® code hopping devices, Serial EEPROMs, microperipherals, non-volatile memory and analog products. In addition, Microchip's quality system for the design and manufacture of development systems is ISO 9001 certified.



MICROCHIP

WORLDWIDE SALES AND SERVICE

AMERICAS

Corporate Office

2355 West Chandler Blvd.
Chandler, AZ 85224-6199
Tel: 480-792-7200 Fax: 480-792-7277
Technical Support: 480-792-7627
Web Address: <http://www.microchip.com>

Rocky Mountain

2355 West Chandler Blvd.
Chandler, AZ 85224-6199
Tel: 480-792-7966 Fax: 480-792-7456

Atlanta

500 Sugar Mill Road, Suite 200B
Atlanta, GA 30350
Tel: 770-640-0034 Fax: 770-640-0307

Boston

2 Lan Drive, Suite 120
Westford, MA 01886
Tel: 978-692-3848 Fax: 978-692-3821

Chicago

333 Pierce Road, Suite 180
Itasca, IL 60143
Tel: 630-285-0071 Fax: 630-285-0075

Dallas

4570 Westgrove Drive, Suite 160
Addison, TX 75001
Tel: 972-818-7423 Fax: 972-818-2924

Detroit

Tri-Atria Office Building
32255 Northwestern Highway, Suite 190
Farmington Hills, MI 48334
Tel: 248-538-2250 Fax: 248-538-2260

Kokomo

2767 S. Albright Road
Kokomo, Indiana 46902
Tel: 765-864-8360 Fax: 765-864-8387

Los Angeles

18201 Von Karman, Suite 1090
Irvine, CA 92612
Tel: 949-263-1888 Fax: 949-263-1338

New York

150 Motor Parkway, Suite 202
Hauppauge, NY 11788
Tel: 631-273-5305 Fax: 631-273-5335

San Jose

Microchip Technology Inc.
2107 North First Street, Suite 590
San Jose, CA 95131
Tel: 408-436-7950 Fax: 408-436-7955

Toronto

6285 Northam Drive, Suite 108
Mississauga, Ontario L4V 1X5, Canada
Tel: 905-673-0699 Fax: 905-673-6509

ASIA/PACIFIC

Australia

Microchip Technology Australia Pty Ltd
Suite 22, 41 Rawson Street
Epping 2121, NSW
Australia
Tel: 61-2-9868-6733 Fax: 61-2-9868-6755

China - Beijing

Microchip Technology Consulting (Shanghai)
Co., Ltd., Beijing Liaison Office
Unit 915
Bei Hai Wan Tai Bldg.
No. 6 Chaoyangmen Beidajie
Beijing, 100027, No. China
Tel: 86-10-85282100 Fax: 86-10-85282104

China - Chengdu

Microchip Technology Consulting (Shanghai)
Co., Ltd., Chengdu Liaison Office
Rm. 2401, 24th Floor,
Ming Xing Financial Tower
No. 88 TIDU Street
Chengdu 610016, China
Tel: 86-28-6766200 Fax: 86-28-6766599

China - Fuzhou

Microchip Technology Consulting (Shanghai)
Co., Ltd., Fuzhou Liaison Office
Unit 28F, World Trade Plaza
No. 71 Wusi Road
Fuzhou 350001, China
Tel: 86-591-7503506 Fax: 86-591-7503521

China - Shanghai

Microchip Technology Consulting (Shanghai)
Co., Ltd.
Room 701, Bldg. B
Far East International Plaza
No. 317 Xian Xia Road
Shanghai, 200051
Tel: 86-21-6275-5700 Fax: 86-21-6275-5060

China - Shenzhen

Microchip Technology Consulting (Shanghai)
Co., Ltd., Shenzhen Liaison Office
Rm. 1315, 13/F, Shenzhen Kerry Centre,
Renminnan Lu
Shenzhen 518001, China
Tel: 86-755-2350361 Fax: 86-755-2366086

Hong Kong

Microchip Technology Hongkong Ltd.
Unit 901-6, Tower 2, Metroplaza
223 Hing Fong Road
Kwai Fong, N.T., Hong Kong
Tel: 852-2401-1200 Fax: 852-2401-3431

India

Microchip Technology Inc.
India Liaison Office
Divyasree Chambers
1 Floor, Wing A (A3/A4)
No. 11, O'Shaugnessey Road
Bangalore, 560 025, India
Tel: 91-80-2290061 Fax: 91-80-2290062

Japan

Microchip Technology Japan K.K.
Benex S-1 6F
3-18-20, Shinyokohama
Kohoku-Ku, Yokohama-shi
Kanagawa, 222-0033, Japan
Tel: 81-45-471-6166 Fax: 81-45-471-6122

Korea

Microchip Technology Korea
168-1, Youngbo Bldg. 3 Floor
Samsung-Dong, Kangnam-Ku
Seoul, Korea 135-882
Tel: 82-2-554-7200 Fax: 82-2-558-5934

Singapore

Microchip Technology Singapore Pte Ltd.
200 Middle Road
#07-02 Prime Centre
Singapore, 188980
Tel: 65-6334-8870 Fax: 65-6334-8850

Taiwan

Microchip Technology Taiwan
11F-3, No. 207
Tung Hua North Road
Taipei, 105, Taiwan
Tel: 886-2-2717-7175 Fax: 886-2-2545-0139

EUROPE

Denmark

Microchip Technology Nordic ApS
Regus Business Centre
Lautrup høj 1-3
Ballerup DK-2750 Denmark
Tel: 45 4420 9895 Fax: 45 4420 9910

France

Microchip Technology SARL
Parc d'Activite du Moulin de Massy
43 Rue du Saule Trapu
Batiment A - 1er Etage
91300 Massy, France
Tel: 33-1-69-53-63-20 Fax: 33-1-69-30-90-79

Germany

Microchip Technology GmbH
Gustav-Heinemann Ring 125
D-81739 Munich, Germany
Tel: 49-89-627-144 0 Fax: 49-89-627-144-44

Italy

Microchip Technology SRL
Centro Direzionale Colleoni
Palazzo Taurus 1 V. Le Colleoni 1
20041 Agrate Brianza
Milan, Italy
Tel: 39-039-65791-1 Fax: 39-039-6899883

United Kingdom

Arizona Microchip Technology Ltd.
505 Eskdale Road
Winnersh Triangle
Wokingham
Berkshire, England RG41 5TU
Tel: 44 118 921 5869 Fax: 44-118 921-5820

03/01/02





Компания «ЭлектроПласт» предлагает заключение долгосрочных отношений при поставках импортных электронных компонентов на взаимовыгодных условиях!

Наши преимущества:

- Оперативные поставки широкого спектра электронных компонентов отечественного и импортного производства напрямую от производителей и с крупнейших мировых складов;
- Поставка более 17-ти миллионов наименований электронных компонентов;
- Поставка сложных, дефицитных, либо снятых с производства позиций;
- Оперативные сроки поставки под заказ (от 5 рабочих дней);
- Экспресс доставка в любую точку России;
- Техническая поддержка проекта, помощь в подборе аналогов, поставка прототипов;
- Система менеджмента качества сертифицирована по Международному стандарту ISO 9001;
- Лицензия ФСБ на осуществление работ с использованием сведений, составляющих государственную тайну;
- Поставка специализированных компонентов (Xilinx, Altera, Analog Devices, Intersil, Interpoint, Microsemi, Aeroflex, Peregrine, Syfer, Eurofarad, Texas Instrument, Miteq, Cobham, E2V, MA-COM, Hittite, Mini-Circuits, General Dynamics и др.);

Помимо этого, одним из направлений компании «ЭлектроПласт» является направление «Источники питания». Мы предлагаем Вам помощь Конструкторского отдела:

- Подбор оптимального решения, техническое обоснование при выборе компонента;
- Подбор аналогов;
- Консультации по применению компонента;
- Поставка образцов и прототипов;
- Техническая поддержка проекта;
- Защита от снятия компонента с производства.



Как с нами связаться

Телефон: 8 (812) 309 58 32 (многоканальный)

Факс: 8 (812) 320-02-42

Электронная почта: org@eplast1.ru

Адрес: 198099, г. Санкт-Петербург, ул. Калинина, дом 2, корпус 4, литера А.