

1 pC Charge Injection, 100 pA Maximum Leakage, +5 V / +3 V, SPDT Analog Switch

DESCRIPTION

The DG9431E is a monolithic CMOS switch designed for precision signal switching. The 17 Ω low voltage part exhibits low charge injection over the full signal range, low leakage, low parasitic capacitance, and fast switching.

The DG9431E can switch both analog and digital signals. Each switch conducts equally well in both directions when on, and blocks up to the power supply level when off. Break-before-make switching is guaranteed.

The DG9431E offers 1 nW typical power consumption and 8 kV ESD (HBM), 1 kV ESD (CDM) tolerance. It is ideal for use in low voltage instruments and healthcare devices, fitting the circuits of low voltage ADC and DAC, sample and hold, analog front end gain control, and signal path switching. The DG9431E is available in 6-lead TSOP and 8-lead SOIC packages.

APPLICATIONS

- Automatic test equipment
- Process control and automation
- Data acquisition systems
- Meters and instruments
- Medical and healthcare systems
- Communication systems
- Sample-and-hold systems
- Relay replacements
- Battery powered systems

FEATURES

- 1 pC charge injection
- Guaranteed 100 pA max. switch on leakage at 25 $^{\circ}\text{C}$
- 3.8 pF switch off and 7.8 pF switch on capacitances
- +2.7 V to +5 V single supply operation
- Low on-resistance - $R_{\text{DS(on)}}$: 17 Ω (typ.) at 5 V
- t_{ON} : 32 ns, t_{OFF} : 10 ns switching time
- Typical power consumption: 1 nW
- Over voltage tolerance on logic control IN pin
- TTL / CMOS compatible
- ESD (HBM): > 8000 V, ESD (CDM): >1000 V
- Latch-up current: > 300 mA (JESD78)
- Available in TSOP-6 and SOIC-8



Note

* This datasheet provides information about parts that are RoHS-compliant and / or parts that are non-RoHS-compliant. For example, parts with lead (Pb) terminations are not RoHS-compliant. Please see the information / tables in this datasheet for details.

BENEFITS

- Low charge injection and leakage
- Low parasitic capacitance
- Fast switching speed
- High ESD tolerance

FUNCTIONAL BLOCK DIAGRAM AND PIN CONFIGURATION

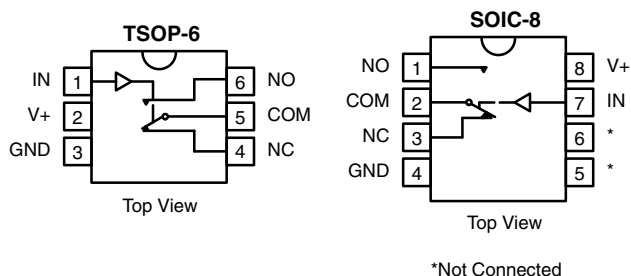

TRUTH TABLE		
LOGIC	NC	NO
0	ON	OFF
1	OFF	ON

Note

- Logic "0" ≤ 0.8 V
- Logic "1" ≥ 2.4 V

ORDERING INFORMATION				
TEMP. RANGE	CONFIGURATION	PART NUMBER	PACKAGE	MINIUM ORDER / PACKAGING QUANTITY
-40 $^{\circ}\text{C}$ to +85 $^{\circ}\text{C}$	DG9431E	6-pin TSOP	DG9431EDV-T1-GE3	Tape and reel 3000 units
		8-pin SOIC	DG9431EDY-T1-GE3	Tape and reel 2500 units
			DG9431EDY-GE3	Tube 500 units



ABSOLUTE MAXIMUM RATINGS			
PARAMETER	LIMIT		UNIT
Reference V+ to GND	-0.3 to +6		V
IN, COM, NC, NO ^a	-0.3 to (V+ + 0.3)		
Continuous current (any terminal)	± 20		mA
Peak current (pulsed at 1 ms, 10 % duty cycle)	± 40		
ESD (HBM) (MIL-STD-883, method 3015)	> 8000		V
ESD (CDM) (ANSI / ESDA / JEDEC® JS-002)	> 1000		
Latch up current, per JESD78	300		mA
Storage temperature (D suffix)	-65 to +125		°C
Power dissipation (packages) ^b	8-pin narrow body SOIC ^c	400	mW
	6-pin TSOP ^d	570	

Notes

- a. Signals on SX, DX, or INX exceeding V+ or V- will be clamped by internal diodes. Limit forward diode current to maximum current ratings.
- b. All leads welded or soldered to PC board.
- c. Derate 6.5 mW/°C above 75 °C.
- d. Derate 7 mW/°C above 70 °C.

SPECIFICATIONS (V+ = 3 V)							
PARAMETER	SYMBOL	TEST CONDITIONS UNLESS OTHERWISE SPECIFIED V+ = 3 V, ± 10 %, V _{IN} = 0.8 V or 2.4 V ^e	TEMP. ^a	D SUFFIX -40 °C TO +85 °C			UNIT
				MIN. ^c	TYP. ^b	MAX. ^c	
Analog Switch							
Analog signal range ^d	V _{ANALOG}		Full	0	-	3	V
Drain-source on-resistance	R _{DS(on)}	V _{NO} or V _{NC} = 1.5 V, V+ = 2.7 V I _{COM} = 5 mA	Room	-	35	50	Ω
			Full	-	-	65	
R _{DS(on)} match ^d	ΔR _{DS(on)}	V _{NO} or V _{NC} = 1.5 V	Room	-	0.4	2	
R _{DS(on)} flatness ^f	R _{DS(on)} flatness	V _{NO} or V _{NC} = 1 V and 2 V	Room	-	4	8	
NO or NC off leakage current ^g	I _{NO/NC(off)}	V _{NO} or V _{NC} = 1 V / 2 V, V _{COM} = 2 V / 1 V	Room	-100	5	100	pA
			Full	-5000	-	5000	
COM off leakage current ^g	I _{COM(off)}	V _{COM} = 1 V / 2 V, V _{NO} or V _{NC} = 2 V / 1 V	Room	-100	5	100	pA
			Full	-5000	-	5000	
Channel-on leakage current ^g	I _{COM(on)}	V _{COM} = V _{NO} or V _{NC} = 1 V / 2 V	Room	-200	5	200	pA
			Full	-10 000	-	10 000	
Digital Control							
Input current	I _{INL} or I _{INH}		Full	-	0.001	-	μA
Dynamic Characteristics							
Turn-on time	t _{ON}	V _{NO} or V _{NC} = 1.5 V	Room	-	43	120	ns
			Full	-	-	200	
Turn-Off Time	t _{OFF}	V _{NO} or V _{NC} = 1.5 V	Room	-	16	50	ns
			Full	-	-	120	
Break-before-make time	t _d		Room	3	26	-	
Charge injection	Q _{INJ}	C _L = 1 nF, V _{gen} = 0 V, R _{gen} = 0 Ω	Room	-	-0.28	-	pC
Off-isolation	O _{IRR}	R _L = 50 Ω, C _L = 5 pF, f = 1 MHz	Room	-	-80	-	dB
Crosstalk	X _{TALK}		Room	-	-108	-	
Source off capacitance	C _{S(off)}	f = 1 MHz	Room	-	4	-	pF
Channel-on capacitance	C _{D(on)}		Room	-	8	-	
Power Supply							
Power supply range	V+			2.7	-	5.5	V
Power supply current	I+	V+ = 3.3 V, V _{IN} = 0 V or 3.3 V		-	0.0003	1	μA



SPECIFICATIONS (V+ = 5 V)								
PARAMETER	SYMBOL	TEST CONDITIONS UNLESS OTHERWISE SPECIFIED V+ = 5 V, ± 10 %, VIN = 0.8 V or 2.4 V ^e	TEMP. ^a	D SUFFIX -40 °C to +85 °C			UNIT	
				MIN. ^c	TYP. ^b	MAX. ^c		
Analog Switch								
Analog signal range ^d	V _{ANALOG}		Full	0	-	5	V	
Drain-source on-resistance	R _{DS(on)}	V _{NO} or V _{NC} = 3.5 V, V+ = 4.5 V I _{COM} = 5 mA	Room	-	17	25	Ω	
			Full	-	-	35		
R _{DS(on)} match ^d	ΔR _{DS(on)}	V _{NO} or V _{NC} = 1.5 V	Room	-	0.4	2		
R _{DS(on)} flatness ^f	R _{DS(on)} flatness	V _{NO} or V _{NC} = 1 V, 2 V, and 3 V	Room	-	3.5	6		
NO or NC off leakage current	I _{NO/NC(off)}	V _{NO} or V _{NC} = 1 V / 4 V, V _{COM} = 4 V / 1 V	Room	-100	10	100	pA	
			Full	-5000	-	5000		
COM off leakage current	I _{COM(off)}	V _{COM} = 1 V / 4 V, V _{NO} or V _{NC} = 4 V / 1 V	Room	-100	10	100		
			Full	-5000	-	5000		
Channel-on leakage current	I _{COM(on)}	V _{COM} = V _{NO} or V _{NC} = 1 V / 4 V	Room	-200	-	200		
			Full	-10 000	-	10 000		
Digital Control								
Input current	I _{INL} or I _{INH}		Full	-	0.001	-	μA	
Dynamic Characteristics								
Turn-on time	t _{ON}	V _{NO} or V _{NC} = 3 V	Room	-	32	75	ns	
			Full	-	-	150		
Turn-off time	t _{OFF}		Room	-	10	50		
			Full	-	-	100		
Break-before-make time	t _d			Room	3	22	-	
Charge injection	Q _{INJ}		C _L = 1 nF, V _{gen} = 0 V, R _{gen} = 0 Ω	Room	-	-0.78	-	pC
Off-isolation	O _{IRR}		R _L = 50 Ω, C _L = 5 pF, f = 1 MHz	Room	-	-80	-	dB
Crosstalk	X _{TALK}			Room	-	-108	-	
NC and NO capacitance	C _(off)	f = 1 MHz	Room	-	3.8	-	pF	
Channel-on capacitance	C _{D(on)}		Room	-	7.8	-		
Power Supply								
Power supply range	V+			2.7	-	5.5	V	
Power supply current	I+	V+ = 5.5 V, V _{IN} = 0 V or 5.5 V		-	0.0004	1	μA	

Notes

- a. Room = 25 °C, Full = as determined by the operating suffix.
- b. Typical values are for design aid only, not guaranteed nor subject to production testing.
- c. The algebraic convention whereby the most negative value is a minimum and the most positive a maximum, is used in this datasheet.
- d. Guarantee by design, nor subjected to production test.
- e. V_{IN} = input voltage to perform proper function.
- f. Difference of min and max values.
- g. Guaranteed by 5 V leakage testing, not production tested.

Stresses beyond those listed under "Absolute Maximum Ratings" may cause permanent damage to the device. These are stress ratings only, and functional operation of the device at these or any other conditions beyond those indicated in the operational sections of the specifications is not implied. Exposure to absolute maximum rating conditions for extended periods may affect device reliability.



TYPICAL CHARACTERISTICS ($T_A = 25\text{ }^\circ\text{C}$, unless otherwise noted)

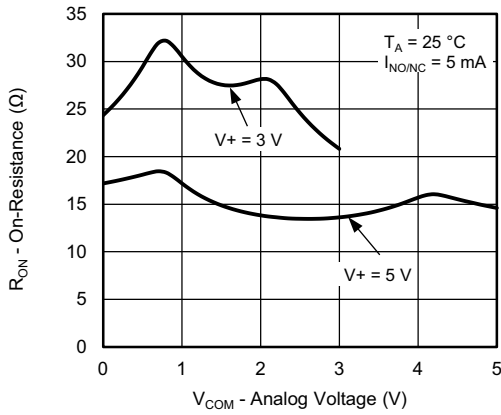

On-Resistance vs. Analog Voltage

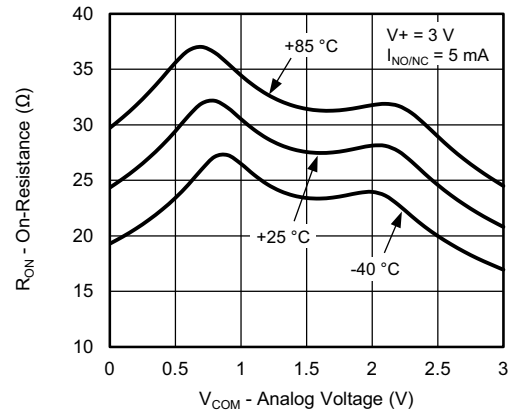

On-Resistance vs. Analog Voltage

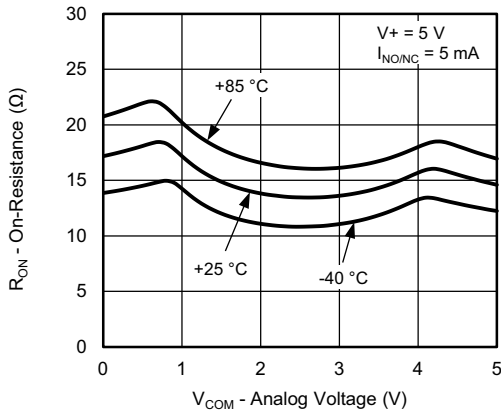

On-Resistance vs. Analog Voltage

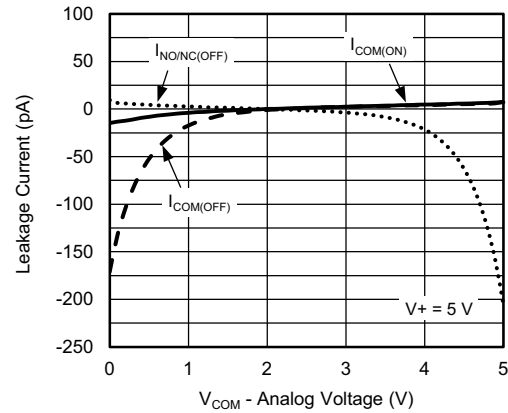

Leakage Current vs. Analog Voltage

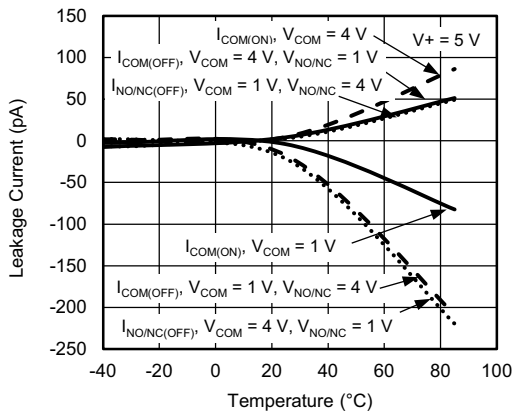

Leakage Current vs. Temperature

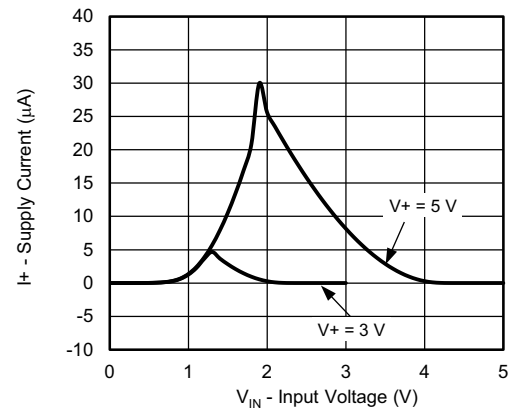

Supply Current vs. Input Voltage



TYPICAL CHARACTERISTICS (T_A = 25 °C, unless otherwise noted)

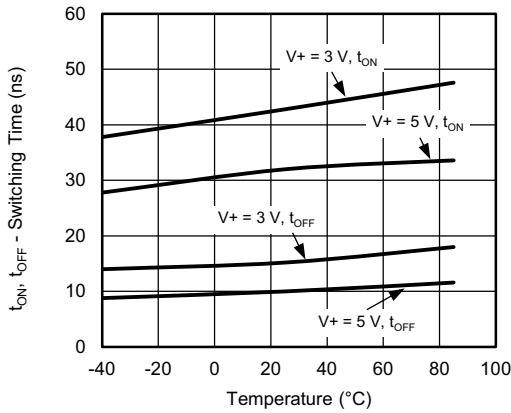

Switching Time vs. Temperature

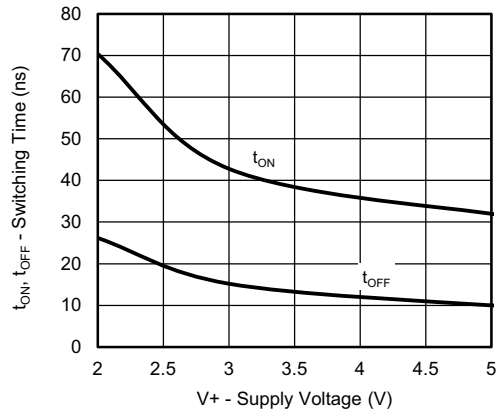

Switching Time vs. Supply Voltage

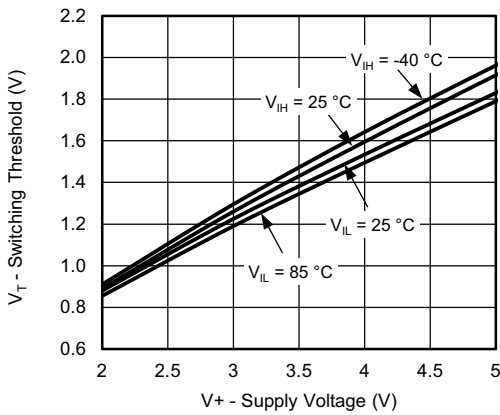

Switching Threshold vs. Supply Voltage

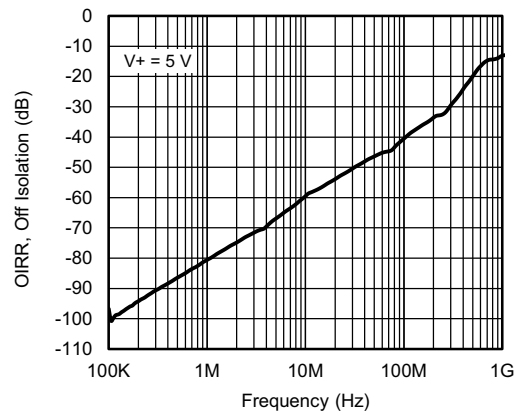

OIRR, Off Isolation vs. Frequency

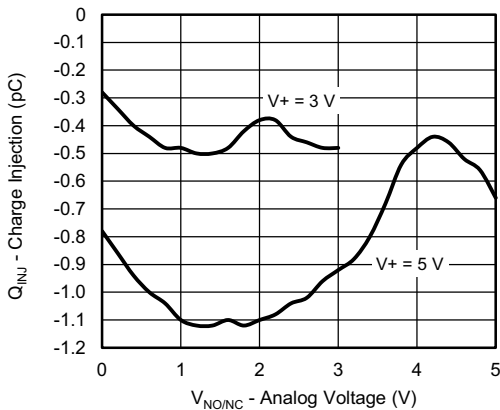

Charge Injection vs. Analog Voltage

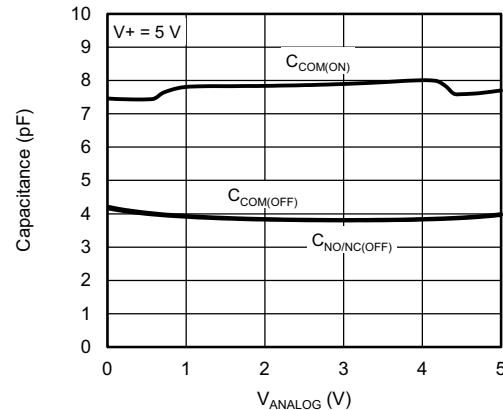

Capacitance

TEST CIRCUITS

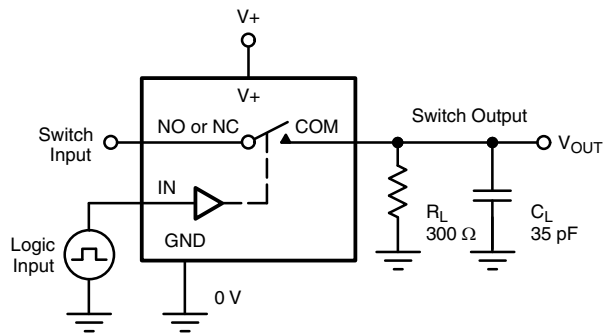

C_L (includes fixture and stray capacitance)

$$V_{OUT} = V_{COM} \left(\frac{R_L}{R_L + R_{ON}} \right)$$

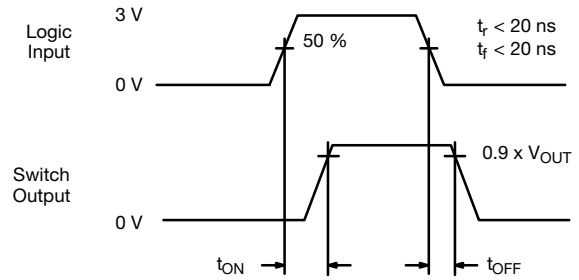

Logic "1" = switch on
Logic input waveforms inverted for switches that have the opposite logic sense.

Figure 1. Switching Time

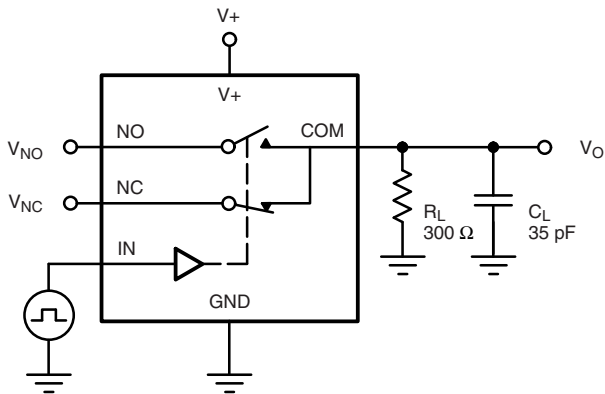

C_L (includes fixture and stray capacitance)

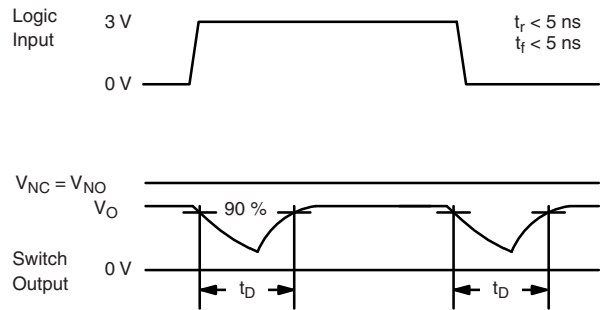
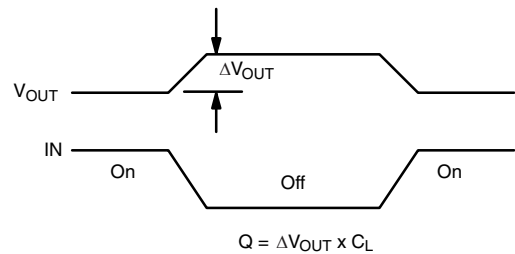
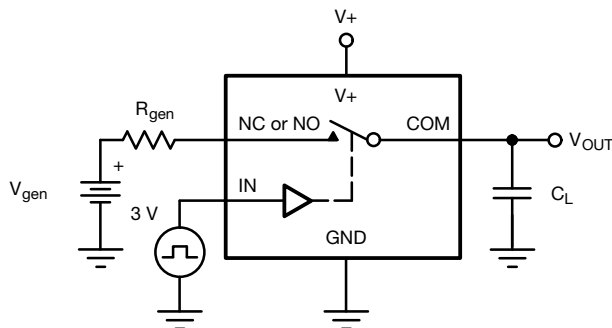
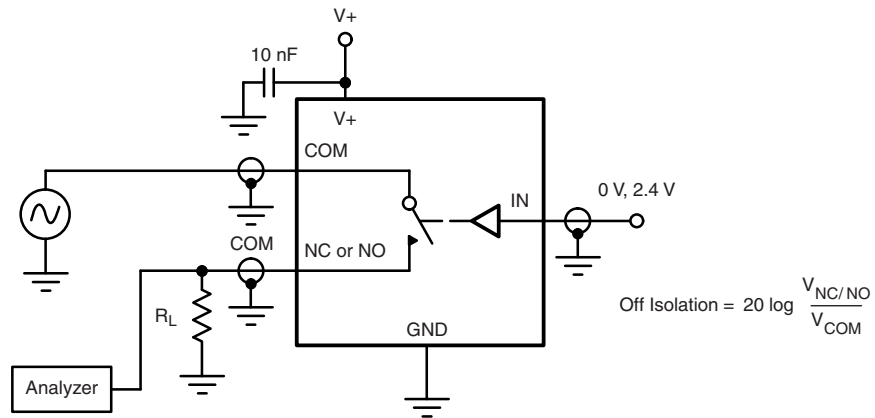
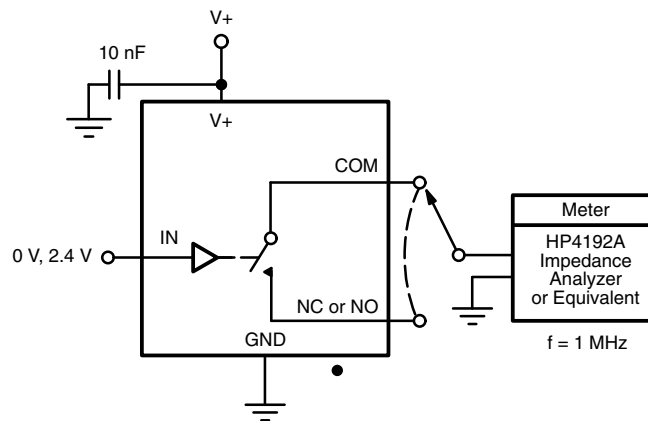

Figure 2. Break-Before-Make Interval



IN depends on switch configuration: input polarity determined by sense of switch.

Figure 3. Charge Injection

TEST CIRCUITS

Figure 4. Off-Isolation

Figure 5. Channel Off/On Capacitance

Vishay Siliconix maintains worldwide manufacturing capability. Products may be manufactured at one of several qualified locations. Reliability data for Silicon Technology and Package Reliability represent a composite of all qualified locations. For related documents such as package/tape drawings, part marking, and reliability data, see www.vishay.com/ppg?76459.

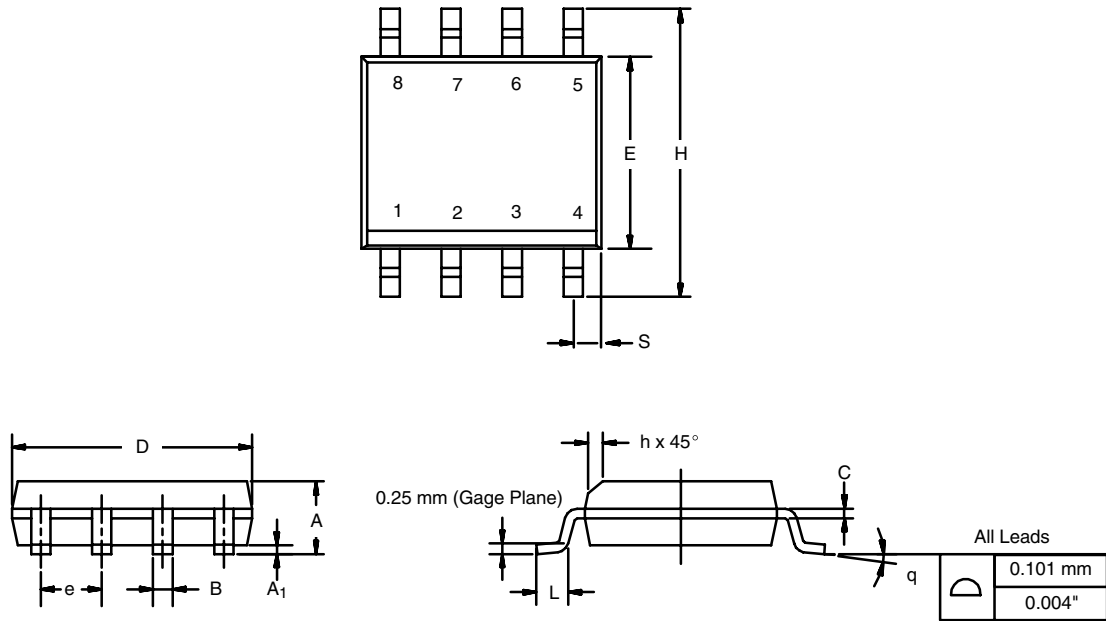
SOIC (NARROW): 8-LEAD

JEDEC Part Number: MS-012



DIM	MILLIMETERS		INCHES	
	Min	Max	Min	Max
A	1.35	1.75	0.053	0.069
A ₁	0.10	0.20	0.004	0.008
B	0.35	0.51	0.014	0.020
C	0.19	0.25	0.0075	0.010
D	4.80	5.00	0.189	0.196
E	3.80	4.00	0.150	0.157
e	1.27 BSC		0.050 BSC	
H	5.80	6.20	0.228	0.244
h	0.25	0.50	0.010	0.020
L	0.50	0.93	0.020	0.037
q	0°	8°	0°	8°
S	0.44	0.64	0.018	0.026
ECN: C-06527-Rev. I, 11-Sep-06				
DWG: 5498				

TSOP: 5/6-LEAD

JEDEC Part Number: MO-193C

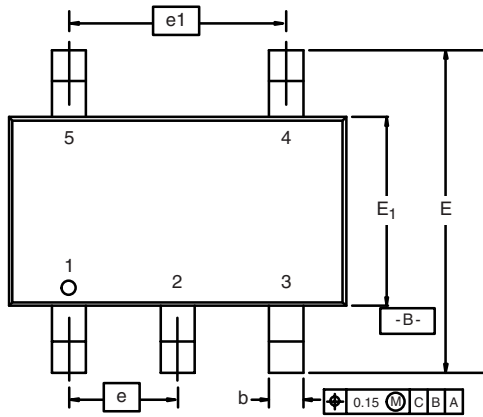

5-LEAD TSOP

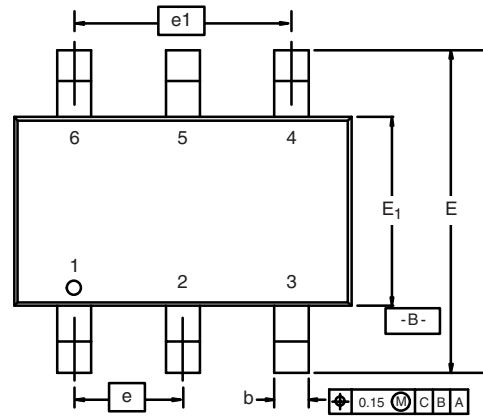

6-LEAD TSOP

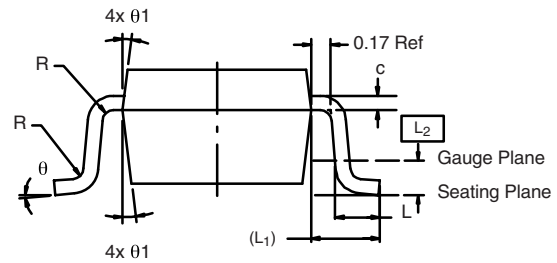
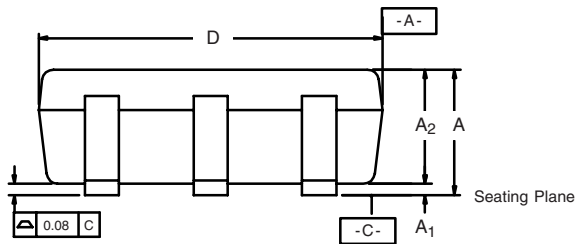

Dim	MILLIMETERS			INCHES		
	Min	Nom	Max	Min	Nom	Max
A	0.91	-	1.10	0.036	-	0.043
A₁	0.01	-	0.10	0.0004	-	0.004
A₂	0.90	-	1.00	0.035	0.038	0.039
b	0.30	0.32	0.45	0.012	0.013	0.018
c	0.10	0.15	0.20	0.004	0.006	0.008
D	2.95	3.05	3.10	0.116	0.120	0.122
E	2.70	2.85	2.98	0.106	0.112	0.117
E₁	1.55	1.65	1.70	0.061	0.065	0.067
e	0.95 BSC			0.0374 BSC		
e₁	1.80	1.90	2.00	0.071	0.075	0.079
L	0.32	-	0.50	0.012	-	0.020
L₁	0.60 Ref			0.024 Ref		
L₂	0.25 BSC			0.010 BSC		
R	0.10	-	-	0.004	-	-
θ	0°	4°	8°	0°	4°	8°
θ₁	7° Nom			7° Nom		
ECN: C-06593-Rev. I, 18-Dec-06						
DWG: 5540						

Mounting LITTLE FOOT[®] TSOP-6 Power MOSFETs

Surface mounted power MOSFET packaging has been based on integrated circuit and small signal packages. Those packages have been modified to provide the improvements in heat transfer required by power MOSFETs. Leadframe materials and design, molding compounds, and die attach materials have been changed. What has remained the same is the footprint of the packages.

The basis of the pad design for surface mounted power MOSFET is the basic footprint for the package. For the TSOP-6 package outline drawing see <http://www.vishay.com/doc?71200> and see <http://www.vishay.com/doc?72610> for the minimum pad footprint. In converting the footprint to the pad set for a power MOSFET, you must remember that not only do you want to make electrical connection to the package, but you must make thermal connection and provide a means to draw heat from the package, and move it away from the package.

In the case of the TSOP-6 package, the electrical connections are very simple. Pins 1, 2, 5, and 6 are the drain of the MOSFET and are connected together. For a small signal device or integrated circuit, typical connections would be made with traces that are 0.020 inches wide. Since the drain pins serve the additional function of providing the thermal connection to the package, this level of connection is inadequate. The total cross section of the copper may be adequate to carry the current required for the application, but it presents a large thermal impedance. Also, heat spreads in a circular fashion from the heat source. In this case the drain pins are the heat sources when looking at heat spread on the PC board.

Figure 1 shows the copper spreading recommended footprint for the TSOP-6 package. This pattern shows the starting point for utilizing the board area available for the heat spreading copper. To create this pattern, a plane of copper overlays the basic pattern on pins 1,2,5, and 6. The copper plane connects the drain pins electrically, but more importantly provides planar copper to draw heat from the drain leads and start the process of spreading the heat so it can be dissipated into the ambient air. Notice that the planar copper is shaped like a "T" to move heat away from the drain leads in all directions. This pattern uses all the available area underneath the body for this purpose.

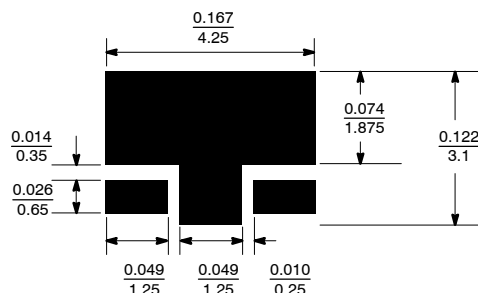

FIGURE 1. Recommended Copper Spreading Footprint

Since surface mounted packages are small, and reflow soldering is the most common form of soldering for surface mount components, "thermal" connections from the planar copper to the pads have not been used. Even if additional planar copper area is used, there should be no problems in the soldering process. The actual solder connections are defined by the solder mask openings. By combining the basic footprint with the copper plane on the drain pins, the solder mask generation occurs automatically.

A final item to keep in mind is the width of the power traces. The absolute minimum power trace width must be determined by the amount of current it has to carry. For thermal reasons, this minimum width should be at least 0.020 inches. The use of wide traces connected to the drain plane provides a low impedance path for heat to move away from the device.

REFLOW SOLDERING

Vishay Siliconix surface-mount packages meet solder reflow reliability requirements. Devices are subjected to solder reflow as a test preconditioning and are then reliability-tested using temperature cycle, bias humidity, HAST, or pressure pot. The solder reflow temperature profile used, and the temperatures and time duration, are shown in Figures 2 and 3.

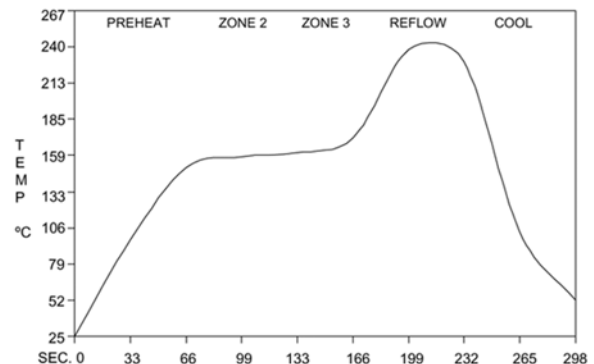

Ramp-Up Rate	+6°C/Second Maximum
Temperature @ 155 ± 15°C	120 Seconds Maximum
Temperature Above 180°C	70 – 180 Seconds
Maximum Temperature	240 +5/-0°C
Time at Maximum Temperature	20 – 40 Seconds
Ramp-Down Rate	+6°C/Second Maximum

FIGURE 2. Solder Reflow Temperature Profile

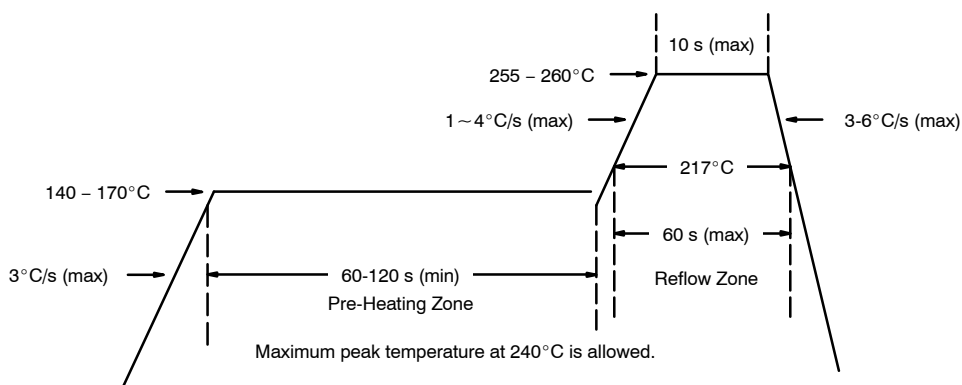

FIGURE 3. Solder Reflow Temperature and Time Durations

THERMAL PERFORMANCE

A basic measure of a device’s thermal performance is the junction-to-case thermal resistance, $R_{\theta_{JC}}$, or the junction-to-foot thermal resistance, $R_{\theta_{JF}}$. This parameter is measured for the device mounted to an infinite heat sink and is therefore a characterization of the device only, in other words, independent of the properties of the object to which the device is mounted. Table 1 shows the thermal performance of the TSOP-6.

TABLE 1.	
Equivalent Steady State Performance—TSOP-6	
Thermal Resistance $R_{\theta_{JF}}$	30°C/W

SYSTEM AND ELECTRICAL IMPACT OF TSOP-6

In any design, one must take into account the change in MOSFET $r_{DS(on)}$ with temperature (Figure 4).

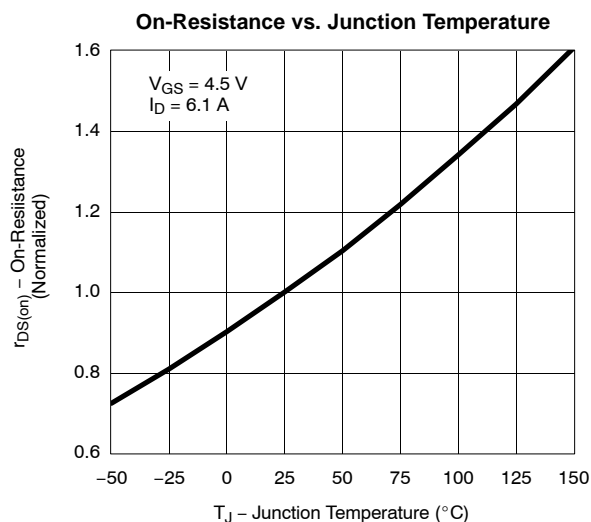
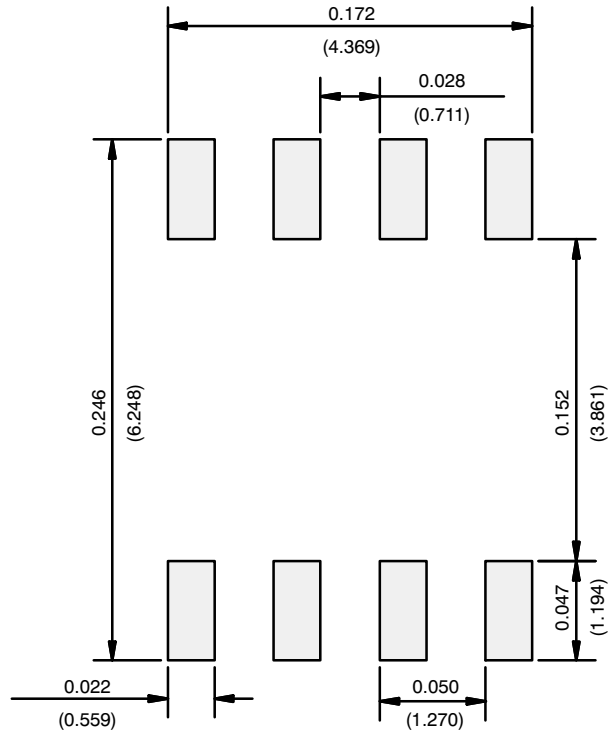

FIGURE 4. Si3434DV

RECOMMENDED MINIMUM PADS FOR SO-8



Recommended Minimum Pads
Dimensions in Inches/(mm)

[Return to Index](#)

RECOMMENDED MINIMUM PADS FOR TSOP-6

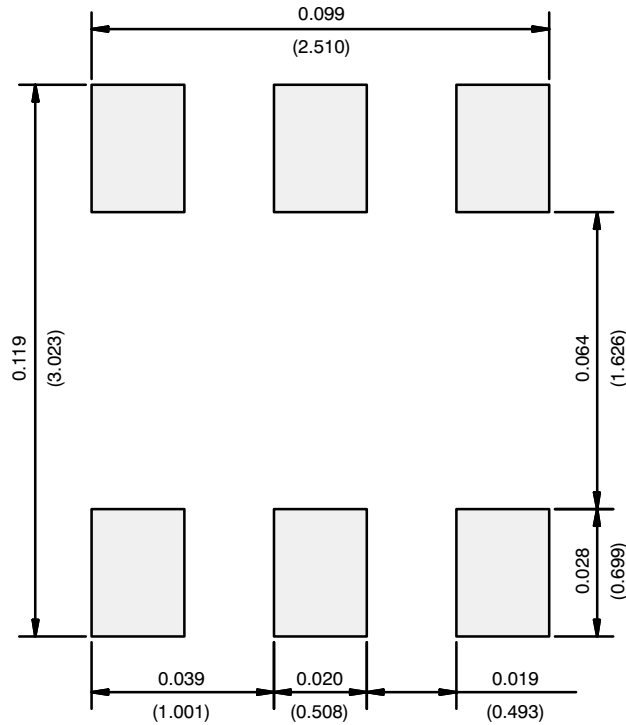

Recommended Minimum Pads
Dimensions in Inches/(mm)

[Return to Index](#)



Disclaimer

ALL PRODUCT, PRODUCT SPECIFICATIONS AND DATA ARE SUBJECT TO CHANGE WITHOUT NOTICE TO IMPROVE RELIABILITY, FUNCTION OR DESIGN OR OTHERWISE.

Vishay Intertechnology, Inc., its affiliates, agents, and employees, and all persons acting on its or their behalf (collectively, "Vishay"), disclaim any and all liability for any errors, inaccuracies or incompleteness contained in any datasheet or in any other disclosure relating to any product.

Vishay makes no warranty, representation or guarantee regarding the suitability of the products for any particular purpose or the continuing production of any product. To the maximum extent permitted by applicable law, Vishay disclaims (i) any and all liability arising out of the application or use of any product, (ii) any and all liability, including without limitation special, consequential or incidental damages, and (iii) any and all implied warranties, including warranties of fitness for particular purpose, non-infringement and merchantability.

Statements regarding the suitability of products for certain types of applications are based on Vishay's knowledge of typical requirements that are often placed on Vishay products in generic applications. Such statements are not binding statements about the suitability of products for a particular application. It is the customer's responsibility to validate that a particular product with the properties described in the product specification is suitable for use in a particular application. Parameters provided in datasheets and / or specifications may vary in different applications and performance may vary over time. All operating parameters, including typical parameters, must be validated for each customer application by the customer's technical experts. Product specifications do not expand or otherwise modify Vishay's terms and conditions of purchase, including but not limited to the warranty expressed therein.

Except as expressly indicated in writing, Vishay products are not designed for use in medical, life-saving, or life-sustaining applications or for any other application in which the failure of the Vishay product could result in personal injury or death. Customers using or selling Vishay products not expressly indicated for use in such applications do so at their own risk. Please contact authorized Vishay personnel to obtain written terms and conditions regarding products designed for such applications.

No license, express or implied, by estoppel or otherwise, to any intellectual property rights is granted by this document or by any conduct of Vishay. Product names and markings noted herein may be trademarks of their respective owners.



Компания «ЭлектроПласт» предлагает заключение долгосрочных отношений при поставках импортных электронных компонентов на взаимовыгодных условиях!

Наши преимущества:

- Оперативные поставки широкого спектра электронных компонентов отечественного и импортного производства напрямую от производителей и с крупнейших мировых складов;
- Поставка более 17-ти миллионов наименований электронных компонентов;
- Поставка сложных, дефицитных, либо снятых с производства позиций;
- Оперативные сроки поставки под заказ (от 5 рабочих дней);
- Экспресс доставка в любую точку России;
- Техническая поддержка проекта, помощь в подборе аналогов, поставка прототипов;
- Система менеджмента качества сертифицирована по Международному стандарту ISO 9001;
- Лицензия ФСБ на осуществление работ с использованием сведений, составляющих государственную тайну;
- Поставка специализированных компонентов (Xilinx, Altera, Analog Devices, Intersil, Interpoint, Microsemi, Aeroflex, Peregrine, Syfer, Eurofarad, Texas Instrument, Miteq, Cobham, E2V, MA-COM, Hittite, Mini-Circuits, General Dynamics и др.);

Помимо этого, одним из направлений компании «ЭлектроПласт» является направление «Источники питания». Мы предлагаем Вам помощь Конструкторского отдела:

- Подбор оптимального решения, техническое обоснование при выборе компонента;
- Подбор аналогов;
- Консультации по применению компонента;
- Поставка образцов и прототипов;
- Техническая поддержка проекта;
- Защита от снятия компонента с производства.



Как с нами связаться

Телефон: 8 (812) 309 58 32 (многоканальный)

Факс: 8 (812) 320-02-42

Электронная почта: org@eplast1.ru

Адрес: 198099, г. Санкт-Петербург, ул. Калинина, дом 2, корпус 4, литера А.