

# ETD-SL-2T-I

Timer relay with adjustable pulse and pause times

## INTERFACE

Data sheet  
102572\_en\_04

© PHOENIX CONTACT - 09/2009



### 1 Description

Increasingly higher demands are being placed on safety and system availability – across all sectors. Processes are becoming more and more complex, not only in mechanical engineering and the chemical industry, but also in plant and automation technology. Demands on power engineering are also increasing constantly.

The timer relays in the ETD series can be used to control time sequences in production and process technology.

### Features

- Adjustable pulse and pause times
- Time range of 50 ms to 100 hours (seven setting ranges)
- Timer function
- Wide-range power supply unit
- Two floating PDTs



**WARNING: Risk of electric shock**

Never carry out work when voltage is present.



Make sure you always use the the latest documentation.  
It can be downloaded at [www.phoenixcontact.net/download](http://www.phoenixcontact.net/download).

## 2 Ordering data

Description	Type	Order No.	Pcs. / Pkt.
Timer relay with adjustable pulse and pause times	ETD-SL-2T-I	2866174	1

## 3 Technical data

Input data	
Input voltage range	24 V DC ... 240 V DC -20 % ... +25 % 24 V AC ... 240 V AC -15 % ... +10 %
Nominal frequency	48 Hz ... 63 Hz
Temperature coefficient, typical	≤ 0.01 %/K
Recovery time	500 ms
Time setting range	50 ms ... 100 h (7 time end ranges)
Function	Ip: Switched-mode beginning with the pause Ii: Switched-mode beginning with the pulse
Basic accuracy	± 1 % (of scale end value)
Setting accuracy	≤ 5 % (of scale end value)
Repeat accuracy	≤ 0.5 % ±5 ms
Nominal power consumption	2.5 VA (1 W)
Output data	
Contact type	2 floating PDT contacts
Nominal insulation voltage	250 V AC (in acc. with IEC 60664-1)
Interrupting rating (ohmic load) max.	750 VA (3 A/250 V AC, module aligned, ≤ 5 mm spacing) 1250 VA (5 A/250 V AC, module not aligned, ≥ 5 mm spacing)
Output fuse	5 A (fast-blow)
General data	
Service life mechanical	Approx. $2 \times 10^7$ cycles
Service life, electrical	Approx. $2 \times 10^5$ cycles at ohmic load, 1000 VA
Switching frequency	max. 60 (per minute at 100 VA ohmic load) max. 6 (per minute at 1000 VA ohmic load)
Operating mode	100% operating factor
Degree of protection	IP40 (housing) / IP20 (connection terminal blocks)
Pollution degree	2 (according to EN 50178)
Surge voltage category	III, basic insulation (as per EN 50178)
Rated insulation voltage	300 V (According to EN 50178)
Inflammability class acc. to UL 94	V0
Assembly	on TS 35 profile rail acc. to EN 60715
Mounting position	Any
Width	22.5 mm
Height	113 mm
Length	90 mm
Type of housing	Polyamide PA, self-extinguishing
Color	green
Weight	160 g

**Connection data**

Conductor cross section, solid	0.5 mm <sup>2</sup> ... 2.5 mm <sup>2</sup>
Conductor cross section, stranded	0.5 mm <sup>2</sup> ... 2.5 mm <sup>2</sup>
Stripping length	8 mm
Type of connection	Screw connection
Tightening torque	1 Nm

**Ambient conditions**

Ambient temperature (operation)	-25 °C ... 55 °C -25 °C ... 40 °C (corresponds to UL 508)
Ambient temperature (storage/transport)	-25 °C ... 70 °C
Permissible humidity (operation)	15 % ... 85 %
Climatic class	3K3 (in acc. with EN 60721)

**Conformance / approvals**

Conformity	CE compliant
UL, USA / Canada	UL/C-UL listed UL 508

**Conformance with EMC directive 2004/108/EC**

Immunity to interference according to	EN 61000-6-2
Emitted interference according to	EN 61000-6-4

**Conformance with LV directive 2006/95/EC**

Industrial timer relays according to	EN 61812-1/A11
--------------------------------------	----------------

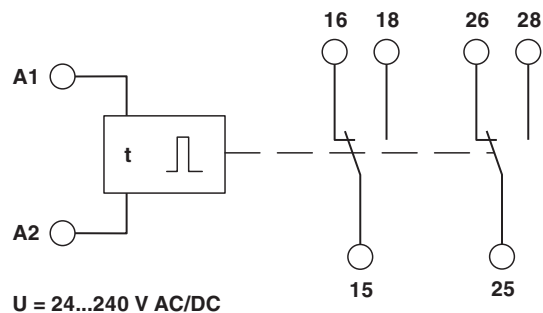
**4 Block diagram****5 Safety notes****WARNING: Risk of electric shock**

Never carry out work when voltage is present.

## 6 Structure

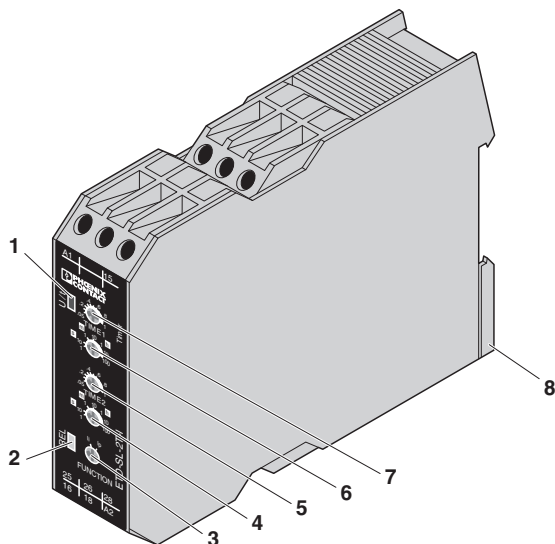

- 1 "U/t" LED: Supply and adjustable time TIME
- 2 "REL" LED: Output relay
- 3 "FUNCTION" rotary switch: Function selection
- 4 Rotary switch "TIME2": Time end range
- 5 "TIME2" potentiometer: Preset value
- 6 Rotary switch "TIME1": Time end range
- 7 "TIME1" potentiometer: Preset value
- 8 Universal snap-on foot for EN DIN rails

## 7 Installation



### WARNING: Risk of electric shock

Never carry out work when voltage is present.

The module can be snapped onto all 35 mm DIN rails according to EN 60715.

An integrated wide-range power supply unit enables the connection of a supply voltage in the range from 24 V AC/DC to 240 V AC/DC.

## 8 Time setting

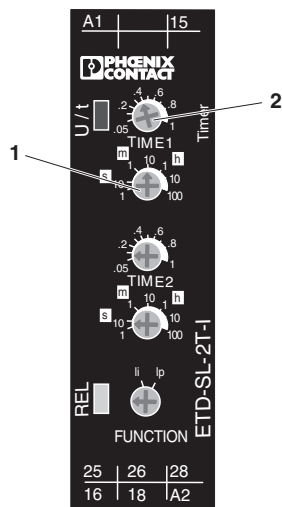

### Example:

Setting of time 1

- 1 Specification of the time end range using a rotary switch, e.g. 10 m (10 minutes)
- 2 Fine setting of the time using a potentiometer, e.g. 0.4

**Set time:**  $0.4 * 10 \text{ minutes} = 4 \text{ minutes}$

## 9 Diagnostics

The LEDs indicate the following error states:

### "U/t" LED (Green)

- LED flashes at 0.75 Hz: Voltage present, set time t1 running
- LED flashes at 1.5 Hz: Voltage present, set time t2 running

### "REL" LED (Yellow)

- LED ON: Output relay has picked up
- LED OFF: Output relay has dropped out

## 10 Connection example

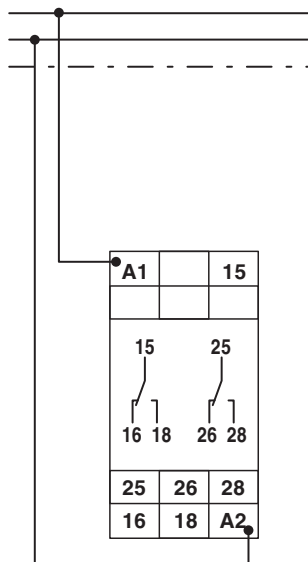

## 11 Function



### ATTENTION: Module can become damaged

Only set the functions when the module is switched off.

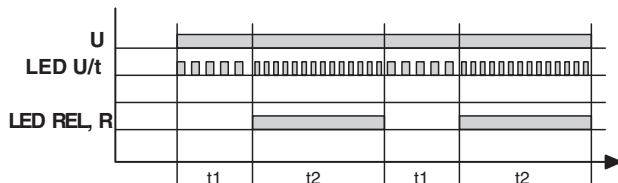

### Ip: Switched-Mode Beginning With Pause

When supply voltage U is applied, set time t1 starts running (green "U/t" LED flashes at 0.75 Hz). Once time t1 has elapsed, the output relay picks up (yellow "REL" LED is ON) and set time t2 starts running (green "U/t" LED flashes at 1.5 Hz).

Once time t2 has elapsed, the output relay drops out (yellow "REL" LED is OFF). The output relay is controlled in relation to set times t1 and t2 until the supply voltage is interrupted.

Time t1 = Pause time

Time t2 = Pulse time

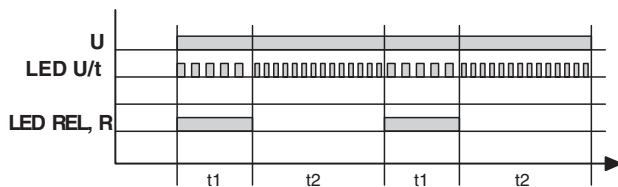

### Ii: Switched-Mode Beginning With Pulse

When supply voltage U is applied, the output relay picks up (yellow "REL" LED is ON) and set time t1 starts running (green "U/t" LED flashes at 0.75 Hz). Once time t1 has elapsed, the output relay drops out (yellow "REL" LED is OFF) and set time t2 starts running (green "U/t" LED flashes at 1.5 Hz).

Once time t2 has elapsed, the output relay picks up again (yellow "REL" LED is ON). The output relay is controlled in relation to set times t1 and t2 until the supply voltage is interrupted.

Time t1 = Pulse time

Time t2 = Pause time



Компания «ЭлектроПласт» предлагает заключение долгосрочных отношений при поставках импортных электронных компонентов на взаимовыгодных условиях!

Наши преимущества:

- Оперативные поставки широкого спектра электронных компонентов отечественного и импортного производства напрямую от производителей и с крупнейших мировых складов;
- Поставка более 17-ти миллионов наименований электронных компонентов;
- Поставка сложных, дефицитных, либо снятых с производства позиций;
- Оперативные сроки поставки под заказ (от 5 рабочих дней);
- Экспресс доставка в любую точку России;
- Техническая поддержка проекта, помощь в подборе аналогов, поставка прототипов;
- Система менеджмента качества сертифицирована по Международному стандарту ISO 9001;
- Лицензия ФСБ на осуществление работ с использованием сведений, составляющих государственную тайну;
- Поставка специализированных компонентов (Xilinx, Altera, Analog Devices, Intersil, Interpoint, Microsemi, Aeroflex, Peregrine, Syfer, Eurofarad, Texas Instrument, Miteq, Cobham, E2V, MA-COM, Hittite, Mini-Circuits, General Dynamics и др.);

Помимо этого, одним из направлений компании «ЭлектроПласт» является направление «Источники питания». Мы предлагаем Вам помощь Конструкторского отдела:

- Подбор оптимального решения, техническое обоснование при выборе компонента;
- Подбор аналогов;
- Консультации по применению компонента;
- Поставка образцов и прототипов;
- Техническая поддержка проекта;
- Защита от снятия компонента с производства.



#### Как с нами связаться

**Телефон:** 8 (812) 309 58 32 (многоканальный)

**Факс:** 8 (812) 320-02-42

**Электронная почта:** [org@eplast1.ru](mailto:org@eplast1.ru)

**Адрес:** 198099, г. Санкт-Петербург, ул. Калинина, дом 2, корпус 4, литера А.