

Self powered digital input current limiter

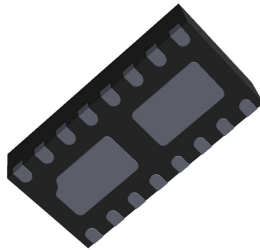

QFN 2X4-16L

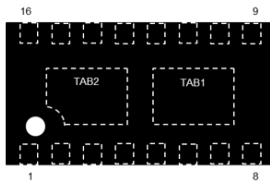

Features

- 2 isolated channels device
- No power supply needed
- Digital input current limitation
- Deglitch filter for EMC robustness
- High side / Low side compatible
- Inputs are reverse plugin compatible
- Direct opto-coupler or 3.3 V LVTTTL output
- Operating ambient temperature range from $-30\text{ }^{\circ}\text{C}$ to $125\text{ }^{\circ}\text{C}$
- QFN 2 x 4 – 16L - 500 μm pitch
- Exceeds IEC 61000-4-2 level 1 standard:
 - $\pm 4\text{ kV}$ (air discharge)
 - $\pm 2\text{ kV}$ (contact discharge)
- IEC61131-2 type 1 and 3
- IEC 61508

Applications

Where current limitation is required in factory automation applications:

- Programmable logic controller
- Remote input module

Product status link

[CLT03-2Q3](#)

Product summary

Order code	CLT03-2Q3
Package	QFN 2X4-16L
Packing	Tape and reel

Description

The CLT03-2Q3 is a digital input current limiter which does not require external power supply.

The product is housed in a QFN 2 x 4 -16L and is high side and low side compatible, as well as reverse plugin compatible.

The CLT03-2Q3 can drive either opto-coupler or 3.3 V LVTTTL circuit.

1 Circuit block diagram

Figure 1. One channel diagram

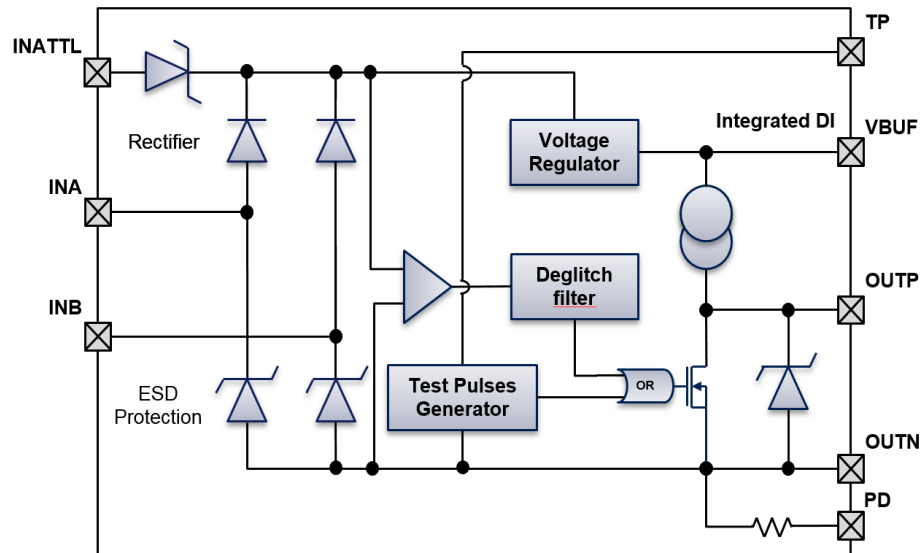

1.1 I/O pin description

Table 1. Pins name, type and description

Name	Pin #	Type	Description
INA1 / INA2	7 / 3	Signal input	Logic input with current limitation
INATTL1 / INATTL2	6 / 2	Signal input	Logic input with current limitation for non-isolated configuration
INB1 / INB2	8 / 4	Signal input	Logic input with current limitation
TP1 / TP2	9 / 14	Test input	Test pulse input for capacitor
VBUF1 / VBUF2	10 / 15	Power output	Buffer capacitor
OUTN1	5 / TAB1	Ground	Logic output ground (channel 1 output ground)
OUTN2	13 / TAB2	Ground	Logic output ground (channel 2 output ground)
OUTP1 / OUTP2	11 / 16	Signal output	Data output
PD1/PD2	12 / 1	Ground	Logic output ground with pull down resistor (non-isolated mode)

Figure 2. QFN 2x4-16L pinout (top view)

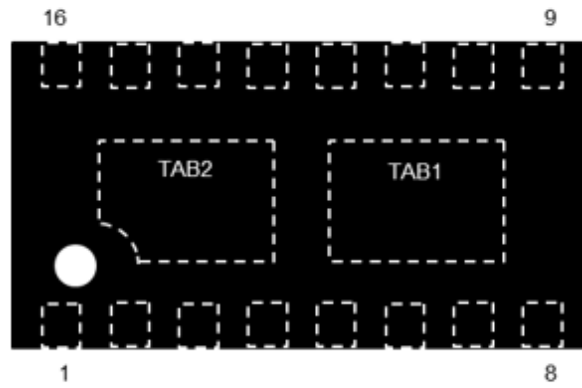

Table 2. Thermal resistance parameter

Symbol	Parameter	Value	Unit
$R_{th(j-a)}$	Thermal resistance junction to ambient, according to EIA/ JEDEC JESD51-7 and JESD51-5	41	°C/W

2 Characteristics

2.1 Absolute ratings

Stresses outside the absolute ratings range may cause permanent damage to the device. These are stress ratings only and functional operation of the device at these conditions is not implied. Exposure to absolute rating conditions for extended periods may affect device reliability.

Table 3. Absolute ratings ($T_{amb} = 25\text{ °C}$, unless otherwise specified)

Symbol	Parameter name	Value	Unit
V_{PP}	Peak pulse voltage, HBM, MIL STD 883J-Method 3015.9	2	kV
$V_{PP}^{(1)(2)}$	Peak pulse voltage (pins INA, INATTL & INB), IEC 61000-4-2 (contact)	2	kV
V_{IN}	Input voltage	-60 to +60	V
V_{ISO}	Isolation between channel 1 and 2	230	V_{AC}
T_J	Junction temperature	-30 to +125	°C
T_{STG}	Storage temperature	-55 to +150	°C

1. See application schematic
2. Performance level depends on layout and environment

2.2 Electrical characteristics

Table 4. Electrical characteristics (-30 °C < T_{ambient} < +125 °C, unless otherwise specified) (values)

Symbol	Description	Name	Min.	Typ.	Max.	Unit
Input						
I _{LIM}	Input current – On state		2.5		4	mA
V _{TLH}	Low to High state input voltage			9.4	11	V
V _{THL}	High to Low state input voltage		5	7.5		V
V _{HYST}	Input triggering voltage hysteresis		1.2		2.6	V
V _{FAULT}	Fault mode threshold voltage		30	40		V
I _{FAULT}	Input current in fault region V _{IN} > V _{FAULT}		1		3	mA
Timing parameters						
f _{IN}	Input frequency				35	kHz
t _{FAULT}	Fault mode triggering latency after V _{IN} > V _{FAULT}			25		µs
t _{PLH}	Input to output low to high propagation time (including deglitch filter) ⁽¹⁾		2		5	µs
t _{PHL}	Input to output high to low propagation time (including deglitch filter) ⁽¹⁾		2		5	µs
Ouput						
I _{OUT}	On state	Isolated mode	2		4	mA
		Non-isolated mode			1	mA
	Off state	Isolated and non-isolated mode	-10		10	µA
V _{OUT}	On state	Isolated mode	0.7		3.6	V
		Non-isolated mode	3		3.6	V
	Off state	Isolated and non-isolated mode	-0.3		0.4	V
R _{OUT}	OUTP to OUTN internal equivalent output resistance (V _{INA} - V _{INB} = 0 V)			24		kΩ
R _{PD}	OUTN to PD internal pull down resistor		2.85		4.25	kΩ

1. See Figure 8. t_{PLH} and t_{PHL} test condition

3 U-I operation description

Figure 3. Input U-I operation

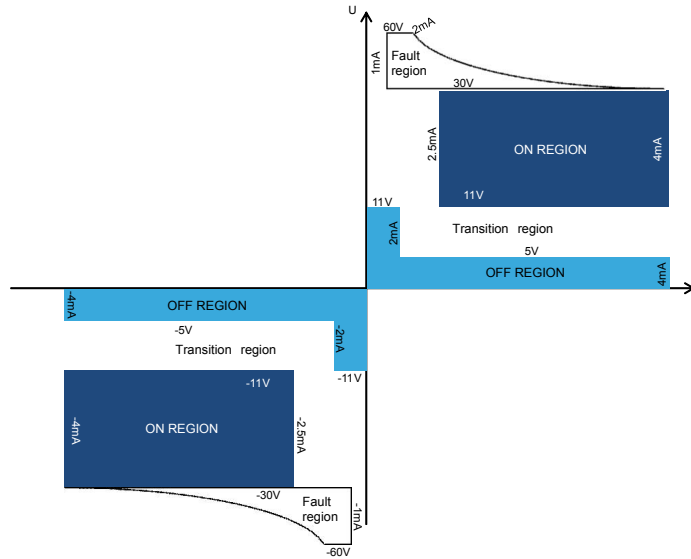
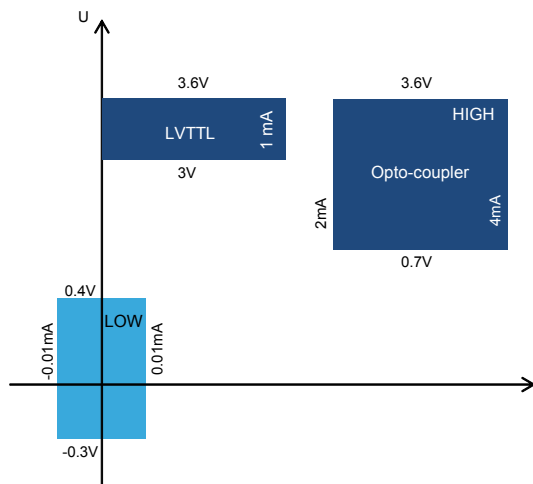

Figure 4. Output U-I operation



4 Fault mode description

When the input voltage V_{IN} exceeds a threshold $V_{FAULT} = 30V$ the CLT03-2Q3 activates the Fault Mode with a defined latency t_{FAULT} . In this mode the CLT03-2Q3 further reduces the input current limitation down to I_{FAULT} and the corresponding output channel is deactivated.

Fault mode ensures defined and safe operation of the CLT03-2Q3 in overvoltage condition as it is often required by safety regulations.

5 Deglitch filter

Figure 5. Deglitch filter

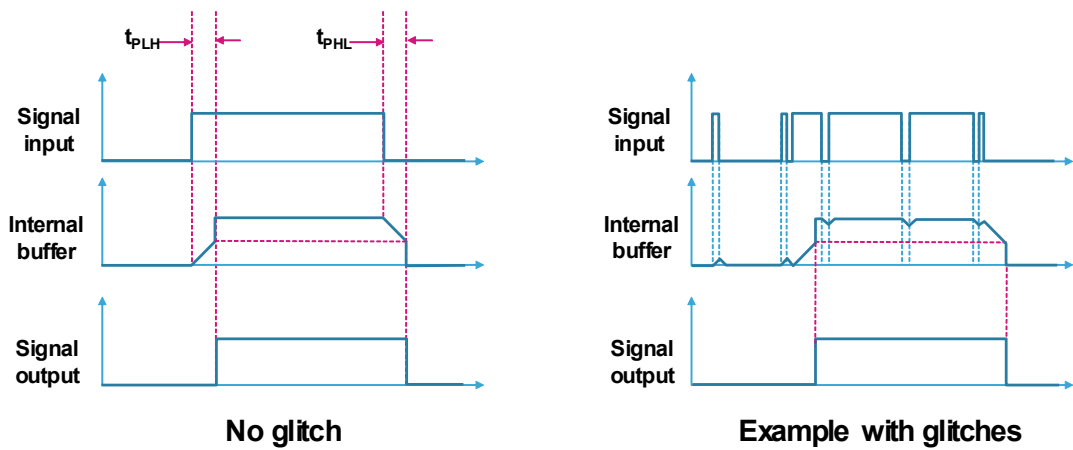

To provide the best EMI robustness solution, a deglitch filter based on a non-resettable mono-stable has been integrated. As described in [Deglitch filter](#), to avoid parasitic spike in output signal when glitches occur in input signals, the integrated internal buffer cleans the glitch effect. The output activation and deactivation action times is defined by t_{PLH} and t_{PHL} when no glitch.

6 Test pulse feature description

The built-in test pulse feature complies with the latest safety standards. Thus, it is possible to know on a regular basis that CLT03-2Q3 is still working properly.

In order, to enable the Test Pulse feature a capacitor should be connected between TP and OUTN pins. When such a capacitor is connected, the OUTP value will be forced to low state every TP period (P_{TP}) for a define test pulse width (t_{TP}). TP period is equal to 256 times t_{TP} .

The frequency of the “Test Pulse low state” is managed through the capacitor value. In order to disable this feature, TP should be shorted to OUTN.

Table 5. Test pulse parameters

Symbol	Description	Min.	Typ.	Max.	Unit
f_{TP}	PTest pulse frequency	4.1		219	kHz
C_{TP}	External capacitor range	100		4700	pF
t_{TP}	Test pulse width	$1/f_{TP}$			ms
P_{TP}	Test pulse period	$256 \times t_{TP}$			ms
Δf_{TP}	Test pulse frequency variation (out of capacitance variation)	-60		+60	%

Figure 6. Test Pulse parameters description

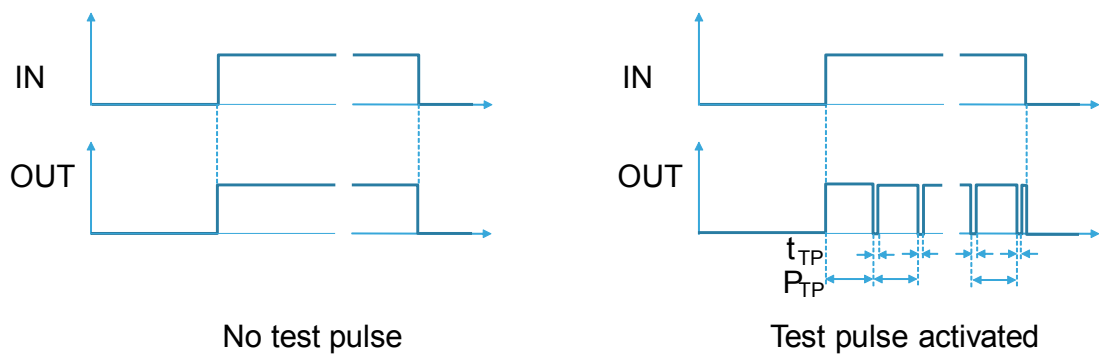
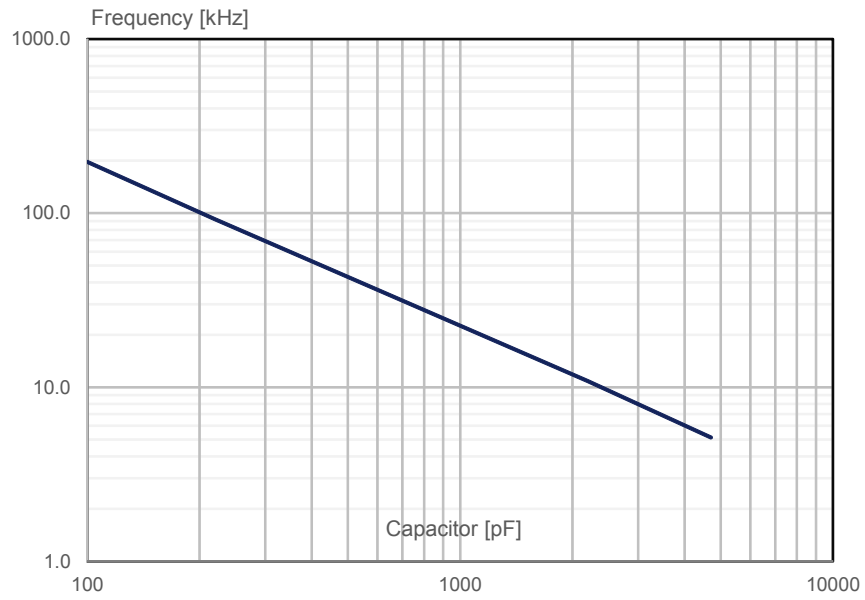
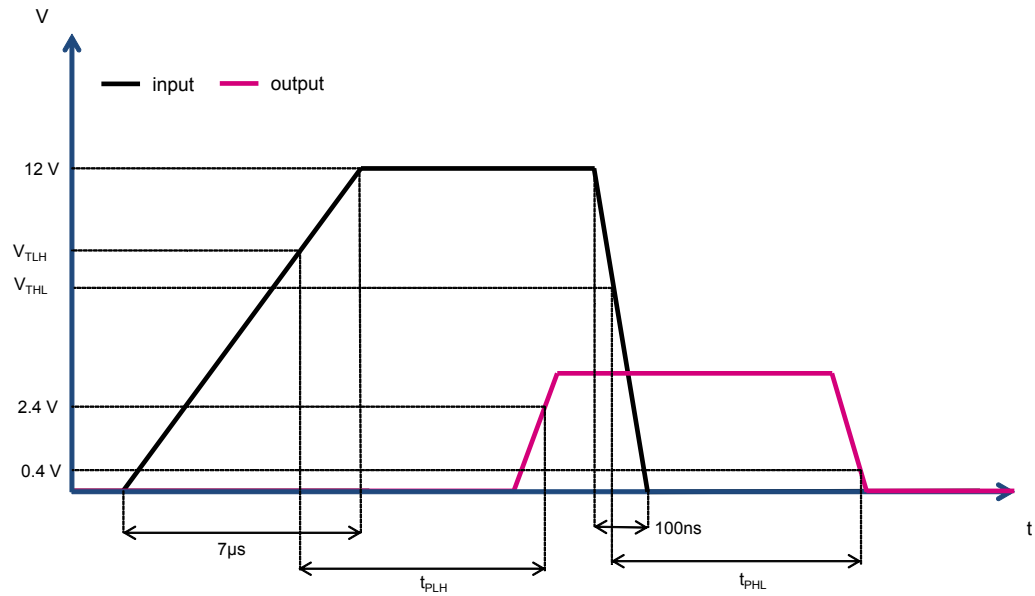

Figure 7. f_{TP} versus C_{TP} value



7 Propagation time measurement description

Figure 8. t_{PLH} and t_{PHL} test condition

Note: for t_{PLH} and t_{PHL} measurement, V_{TLH} and V_{THL} should be determined for each sample. Timing measurement should be done with these samples specific V_{TLH} and V_{THL} thresholds.

8 Simplified application schematic

Table 6. Configuration compatibility of CLT03-2Q3

Symbol	High Side	Low Side
Isolated	Yes	Yes
Non-isolated	Yes	No

Each circuit given in this section is given for 1 channel only.

Figure 9. High side – isolated configuration

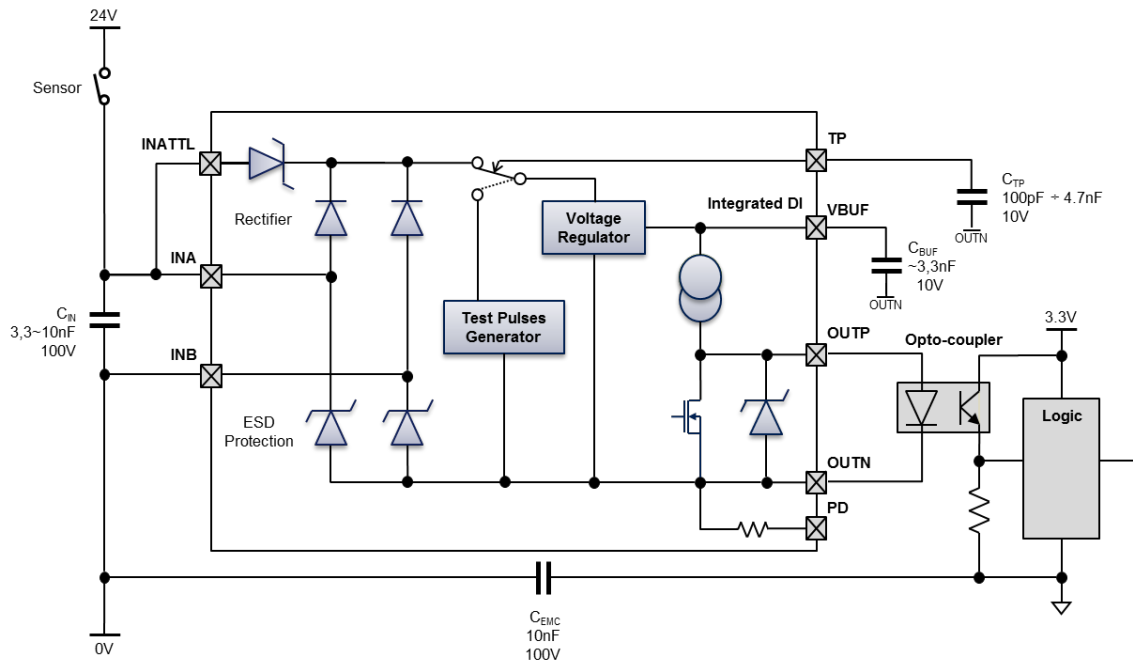
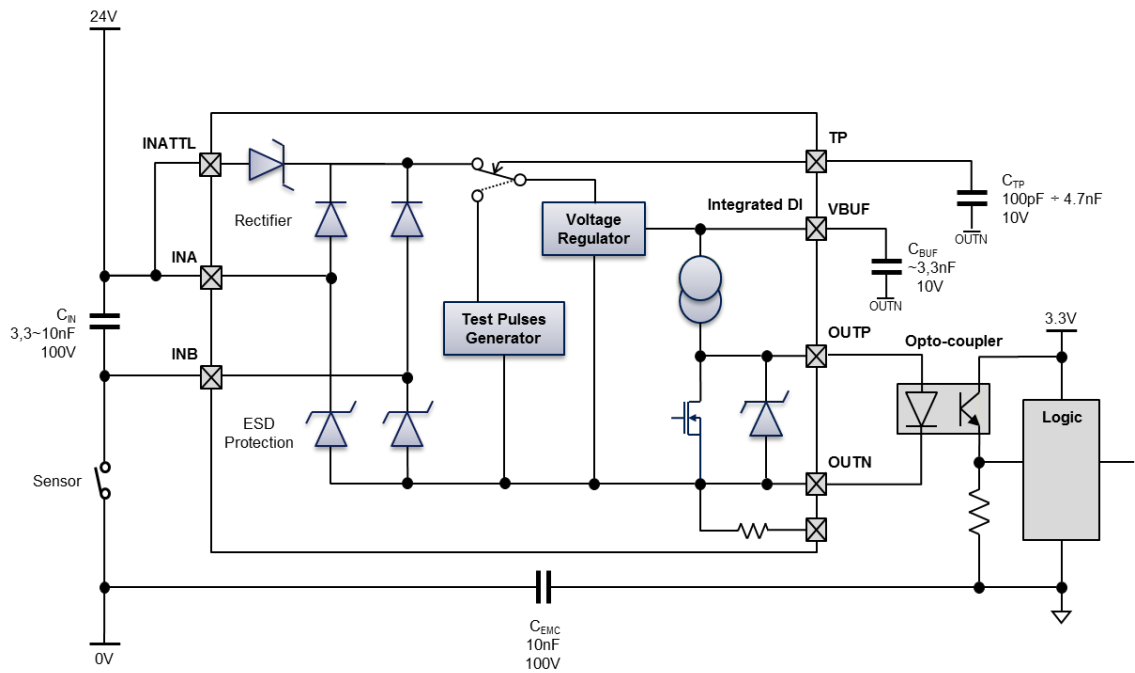
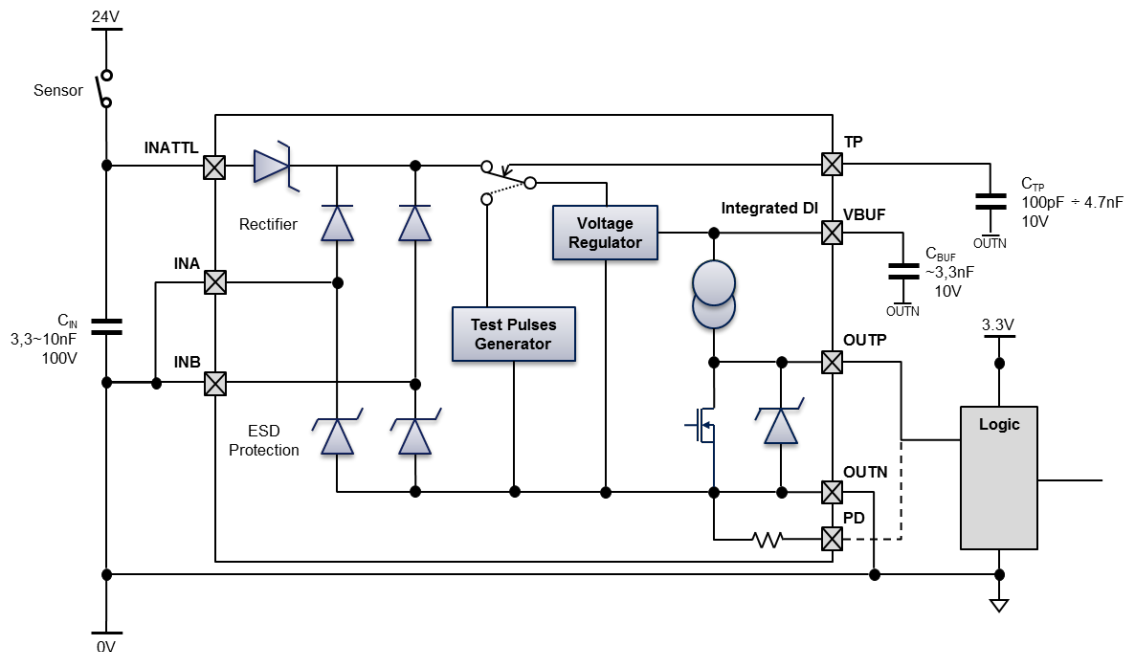

Figure 10. Low side – isolated configuration

Figure 11. High side – non-isolated configuration

Note: OUTP to PD connection is optional.

9 Package information

In order to meet environmental requirements, ST offers these devices in different grades of **ECOPACK** packages, depending on their level of environmental compliance. ECOPACK specifications, grade definitions and product status are available at: www.st.com. ECOPACK is an ST trademark.

9.1 QFN 2X4 -16L package information

Figure 12. QFN 2X4-16L package outline

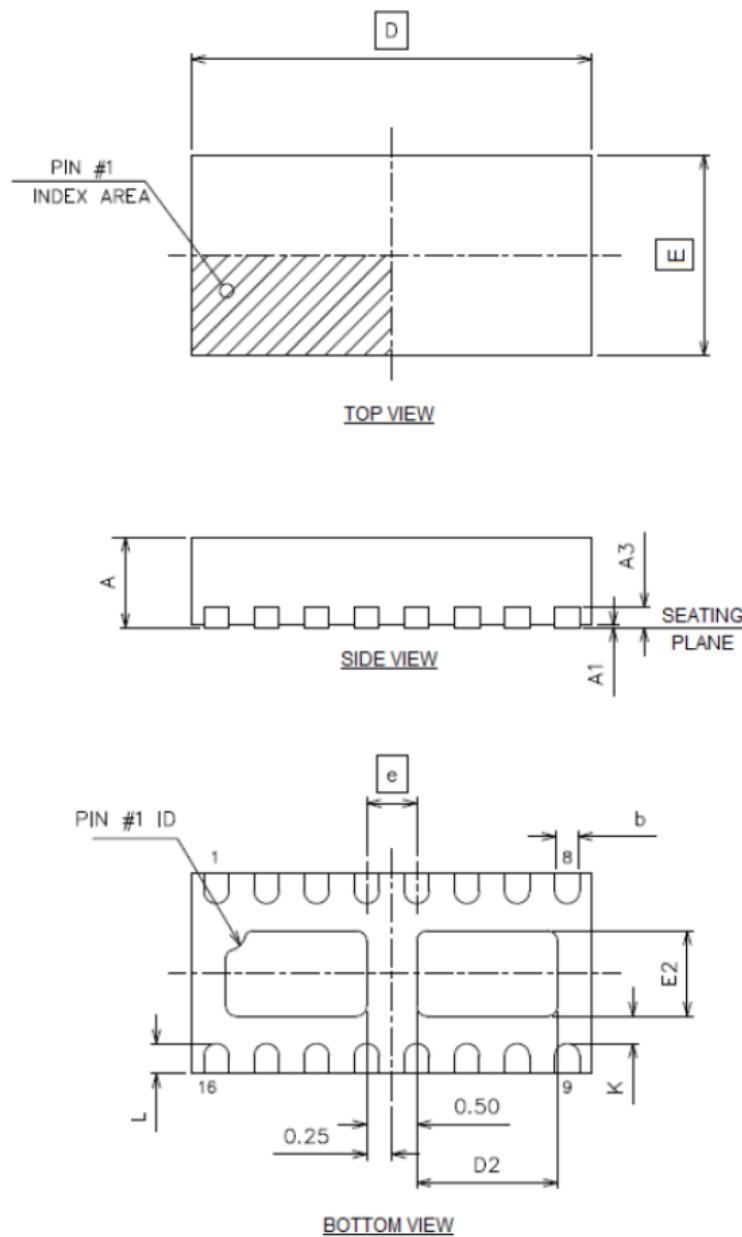

Table 7. QFN 2X4-16L package mechanical data

Ref.	Dimensions					
	Millimeters			Inches ⁽¹⁾		
	Min.	Typ.	Max.	Min.	Typ.	Max.
A	0.80	0.90	1.00	0.0315	0.0354	0.0394
A1		0.02	0.05		0.0008	0.0020
A3		0.20			0.008	
B	0.18	0.25	0.30	0.0071	0.0100	0.0118
D	3.95	4.00	4.05	0.1555	0.1574	0.1594
E	1.95	2.00	2.05	0.0768	0.0787	0.0807
D2	1.25	1.40	1.51	0.0492	0.0551	0.0594
E2	0.70	0.85	0.95	0.0276	0.0334	0.0374
e		0.50			0.0197	
K	0.15			0.0059		
L	0.20	0.30	0.40	0.0079	0.0118	0.0157

1. Values in inches are converted from mm and rounded to 4 decimal digits.

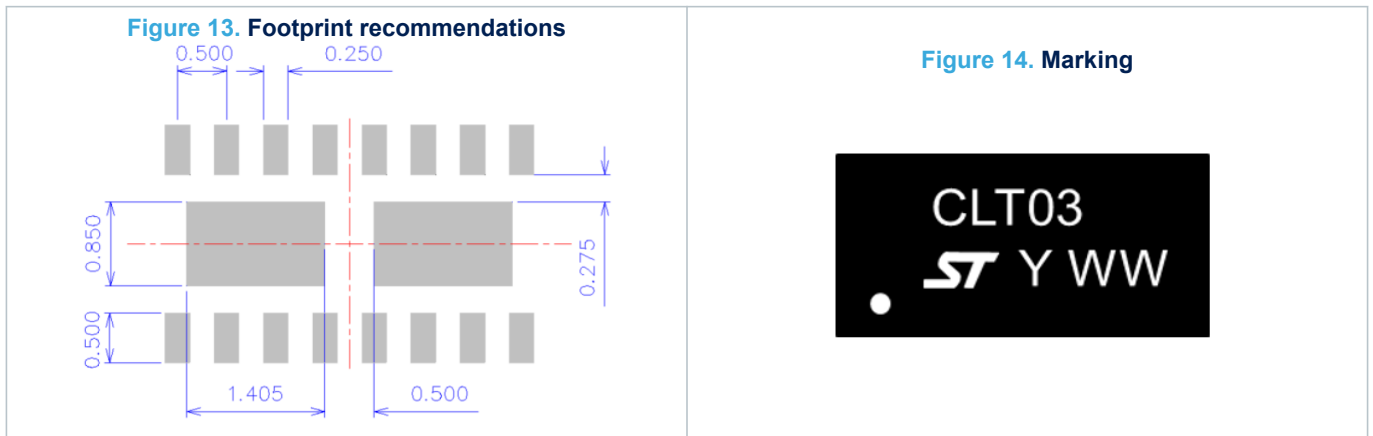
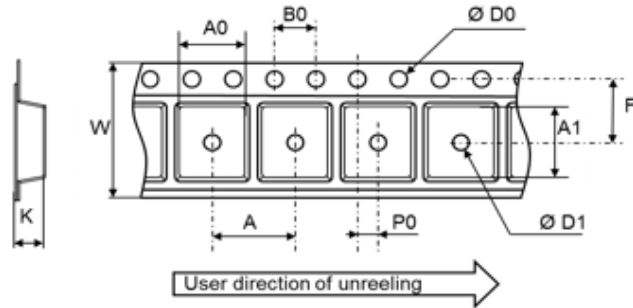

Figure 15. Tape and reel outline



Note: Pocket dimensions are not on scale
Pocket shape may vary depending on package

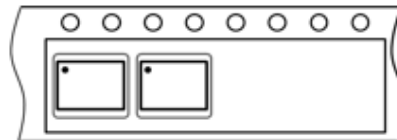
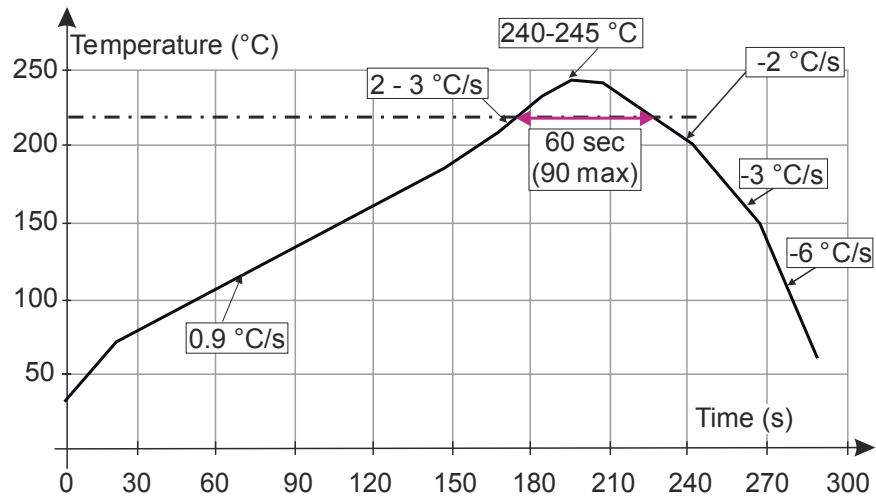

Table 8. Tape and reel mechanical data

Ref.	Dimensions		
	Millimeters		
	Min.	Typ.	Max.
A	3.90	4.00	4.10
A0	2.20	2.25	2.30
A1	4.20	4.25	4.30
B0	3.90	4.00	4.10
ØD0	1.50		1.60
ØD1	1.00		
F	1.65	1.75	1.85
K	1.10	1.15	1.20
P0	1.95	2.00	2.05
W	11.90	12.00	12.30

10 Reflow profile

Figure 16. ST ECOPACK® recommended soldering reflow profile for PCB mounting



Note: Minimize air convection currents in the reflow oven to avoid component movement.

Note: Maximum soldering profile corresponds to the latest IPC/JEDEC J-ST-020.

11 Ordering information

Figure 17. Ordering information scheme

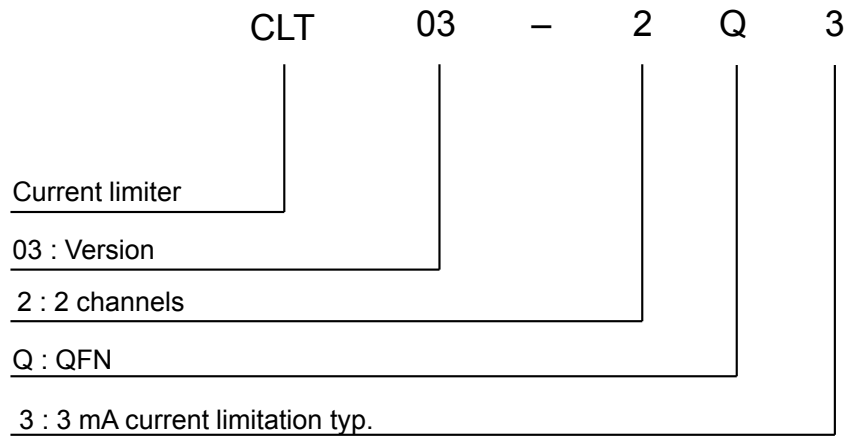

Table 9. Ordering information

Order code	Marking	Package	Weight	Base qty.	Delivery mode
CLT03-2Q3	CLT03	QFN 2 x 4 – 16L	20 mg	3000	Tape and reel

Revision history

Table 10. Document revision history

Date	Revision	Changes
18-Dec-2017	1	Initial release.
11-Dec-2018	2	Minor text change to improve readability.
23-Dec-2019	3	Updated Section Features, Table 4. Electrical characteristics (-30 °C < Tj < +125 °C, unless otherwise specified) (values), Section 8 Simplified application schematic and Figure 6. Test Pulse parameters description. Added Table 2. Thermal resistance parameter and Section 5 Deglitch filter.
06-Feb-2020	4	Updated Table 4. Electrical characteristics (-30 °C < Tj < +125 °C, unless otherwise specified) (values) and Figure 4. Output U-I operation..
04-Mar-2020	5	Updated Section Features, Section 2.1 Absolute ratings and Section 2.2 Electrical characteristics.

IMPORTANT NOTICE – PLEASE READ CAREFULLY

STMicroelectronics NV and its subsidiaries (“ST”) reserve the right to make changes, corrections, enhancements, modifications, and improvements to ST products and/or to this document at any time without notice. Purchasers should obtain the latest relevant information on ST products before placing orders. ST products are sold pursuant to ST’s terms and conditions of sale in place at the time of order acknowledgement.

Purchasers are solely responsible for the choice, selection, and use of ST products and ST assumes no liability for application assistance or the design of Purchasers’ products.

No license, express or implied, to any intellectual property right is granted by ST herein.

Resale of ST products with provisions different from the information set forth herein shall void any warranty granted by ST for such product.

ST and the ST logo are trademarks of ST. For additional information about ST trademarks, please refer to www.st.com/trademarks. All other product or service names are the property of their respective owners.

Information in this document supersedes and replaces information previously supplied in any prior versions of this document.

© 2020 STMicroelectronics – All rights reserved



Компания «ЭлектроПласт» предлагает заключение долгосрочных отношений при поставках импортных электронных компонентов на взаимовыгодных условиях!

Наши преимущества:

- Оперативные поставки широкого спектра электронных компонентов отечественного и импортного производства напрямую от производителей и с крупнейших мировых складов;
- Поставка более 17-ти миллионов наименований электронных компонентов;
- Поставка сложных, дефицитных, либо снятых с производства позиций;
- Оперативные сроки поставки под заказ (от 5 рабочих дней);
- Экспресс доставка в любую точку России;
- Техническая поддержка проекта, помощь в подборе аналогов, поставка прототипов;
- Система менеджмента качества сертифицирована по Международному стандарту ISO 9001;
- Лицензия ФСБ на осуществление работ с использованием сведений, составляющих государственную тайну;
- Поставка специализированных компонентов (Xilinx, Altera, Analog Devices, Intersil, Interpoint, Microsemi, Aeroflex, Peregrine, Syfer, Eurofarad, Texas Instrument, Miteq, Cobham, E2V, MA-COM, Hittite, Mini-Circuits, General Dynamics и др.);

Помимо этого, одним из направлений компании «ЭлектроПласт» является направление «Источники питания». Мы предлагаем Вам помощь Конструкторского отдела:

- Подбор оптимального решения, техническое обоснование при выборе компонента;
- Подбор аналогов;
- Консультации по применению компонента;
- Поставка образцов и прототипов;
- Техническая поддержка проекта;
- Защита от снятия компонента с производства.



Как с нами связаться

Телефон: 8 (812) 309 58 32 (многоканальный)

Факс: 8 (812) 320-02-42

Электронная почта: org@eplast1.ru

Адрес: 198099, г. Санкт-Петербург, ул. Калинина, дом 2, корпус 4, литера А.