

This document is the property of Amphenol Corporation and is delivered on the express condition that it is not to be disclosed, reproduced or used, in whole or in part, for manufacture or sale by anyone other than Amphenol Corporation without its prior consent, and that no right is granted to disclose or to use any information in this document.

The marking on this product doesn't contain environmental hazardous materials per Material Specification SS-00259 for Sony GP compliant or per directive 2011/65/EU for RoHS compliant.



ORIGINAL



REVISIONS				
SYM	ECN No.	DESCRIPTION	DATE	APPROVED
A	NE-14132	NON-RELEASE TO PRODUCTION	07/08/2014	Arron Lin

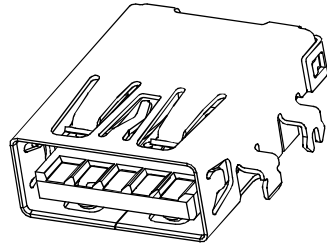
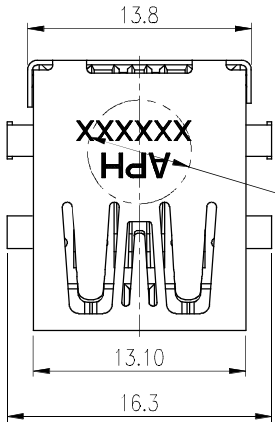

Pin Number	Signal Name
1	VBUS
2	D-
3	D+
4	GND
5	SSRX-
6	SSRX+
7	GND_DRAIN
8	SSTX-
9	SSTX+
Shell	Shield

NOTES:

- MATERIAL:
HOUSING: THERMOPLASTIC, OPTIONS (HALOGEN FREE), UL94V HB COLOR: OPTIONS.
USB2.0 TERMINAL (1~4POS.) : PHOSPHOR BRONZE.
USB3.0 TERMINAL (5~9POS) : BRASS.
SHELL: SUS.
- FINISH:
TERMINAL 2.0 & 3.0 :
CONTACT AREA: SELECTIVE GOLD PLATING.;
SOLDERING AREA: TIN PLATING 100 μ" THICKNESS MIN.;
UNDER PLATING: NICKEL PLATING 50 μ" THICKNESS MIN. OVERALL
SHELL:
NICKEL PLATING 30 μ" THICKNESS MIN. OVERALL.
- PACKING IS PER AMTA PACKING SPECIFICATION PKS-0001.
- THIS PRODUCT DOESN'T CONTAIN ENVIRONMENTAL HAZARDOUS PER DIRECTIVE 2011/65/EU FOR RoHS COMPLIANT.
- PRODUCT SPECIFICATION REFER TO : PS-7530.

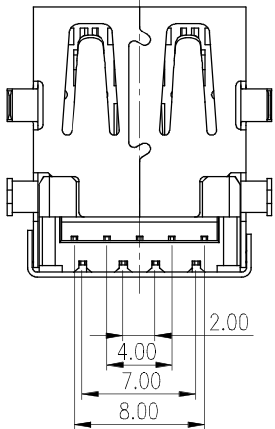
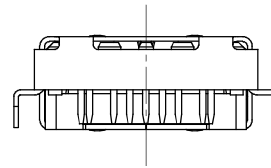
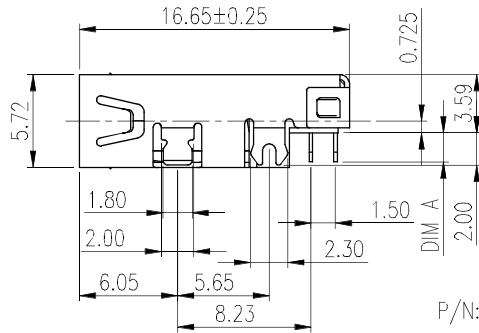
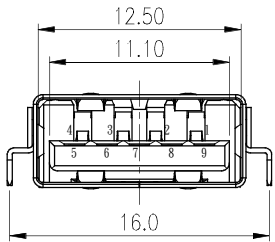

P/N: GSB411B X X X HR
CONTACT FINISH DIM A
1: FLASH GOLD 1: 1.80mm
3: 30u" GOLD 1: 3.00mm
HOUSING /COLOR
3: LCP (BLACK)
4: PA9T (BLUE 300C)

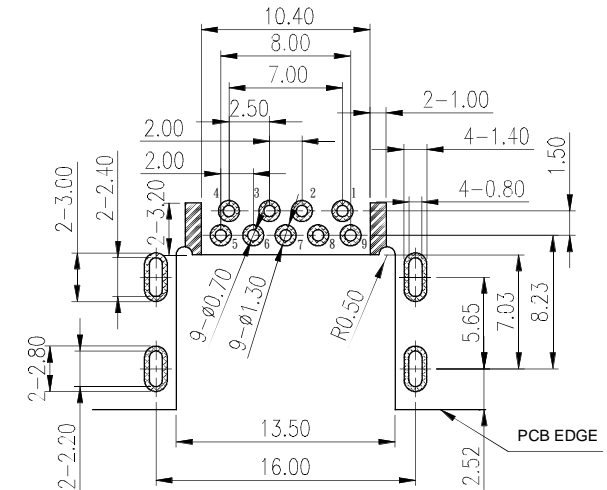

RECOMMENDED PCB LAYOUT
TOP VIEW
TOLERANCE: ±0.05mm
PCB THICKNESS: 1.20±0.05mm
KEEP OUT AREA
RECOMMENDED SOLDER PAD AREA

TOLERANCE	APPROVALS	DATE	TITLE		PART No.	
X. X.X X.XX X.XXX ±0.30 ±0.20 ±0.10	DRAWN Debby Hung	07/08/2014	USB 3.1 TYPE A R/A REVERSE CH=0.725mm SINK DIP TYPE		Amphenol® Amphenol Corporation Amphenol Taiwan Corporation	
ANGULAR ±1°	CHECKED Roger Tsai	07/08/2014	UNIT mm	SIZE A3	PART No. GSB411BXXXHR	
UNLESS OTHERWISE SPECIFIED	APPROVED Arron Lin	07/08/2014	SCALE NA	SHEET 1 OF 2	DWG No. GSB411BXXXHR	REV. A
	DWG TYPE CUST DWG	PROJECT CODE OTHER				

This document is the property of Amphenol Corporation and is delivered on the express condition that it not be disclosed, reproduced or used, in whole or in part, for manufacture or sale by anyone other than Amphenol Corporation without its prior consent, and that no right is granted to disclose or to use any information in this document.

The marking on this product doesn't contain environmental hazardous materials per Material Specification SS-00259 for Sony GP compliant or per directive 2011/65/EU for RoHS compliant.



ORIGINAL



REVISIONS				
SYM	ECN No.	DESCRIPTION	DATE	APPROVED
A	NE-14132	NON-RELEASE TO PRODUCTION	07/08/2014	Arron Lin

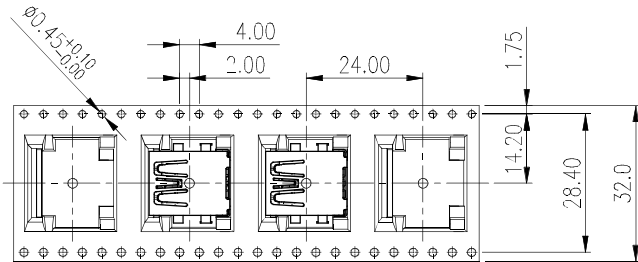

REEL SIZE	PARTS PER CARTON<S.P.Q>	PARTS PER REEL	TOTEL REEL PER CARTON
ø330	7200	450	16

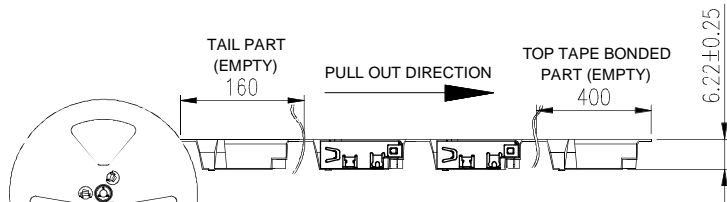

NOTES:

1. STAPLES SHOULD ONLY BE USED TO SET UP CARTON. ALL CARTON CLOSURES MUST BE DONE WITH TAPE.
2. FILL PACKAGING TRAYS WITH THE QUANTITIES AS INDICATED IN THE CHART.
3. SHIPPING CARTON DIMENSION: 690 X 360 X 325mm.
4. NET WEIGHT: 13.7 KG.
GROSS WEIGHT: 24.2 KG.

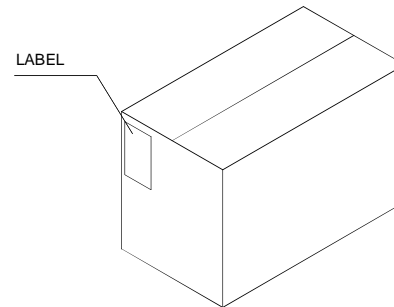
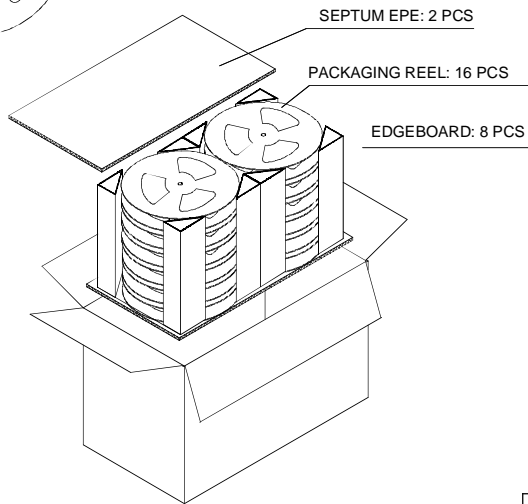

TOLERANCE	APPROVALS	DATE	TITLE		PART No.	
X. ±0.30	DRAWN Debby Hung	07/08/2014	USB 3.1 TYPE A R/A REVERSE CH=0.725mm SINK DIP TYPE		GSB411BXXXHR	
X.X ±0.20	CHECKED Roger Tsai	07/08/2014				
X.XX ±0.10	APPROVED Arron Lin	07/08/2014	UNIT mm	SIZE A3	REV. A	
ANGULAR ±1°	DWG TYPE CUST DWG	PROJECT CODE OTHER	SCALE NA	SHEET 2 OF 2	GSB411BXXXHR	
UNLESS OTHERWISE SPECIFIED						

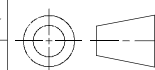



Компания «ЭлектроПласт» предлагает заключение долгосрочных отношений при поставках импортных электронных компонентов на взаимовыгодных условиях!

Наши преимущества:

- Оперативные поставки широкого спектра электронных компонентов отечественного и импортного производства напрямую от производителей и с крупнейших мировых складов;
- Поставка более 17-ти миллионов наименований электронных компонентов;
- Поставка сложных, дефицитных, либо снятых с производства позиций;
- Оперативные сроки поставки под заказ (от 5 рабочих дней);
- Экспресс доставка в любую точку России;
- Техническая поддержка проекта, помощь в подборе аналогов, поставка прототипов;
- Система менеджмента качества сертифицирована по Международному стандарту ISO 9001;
- Лицензия ФСБ на осуществление работ с использованием сведений, составляющих государственную тайну;
- Поставка специализированных компонентов (Xilinx, Altera, Analog Devices, Intersil, Interpoint, Microsemi, Aeroflex, Peregrine, Syfer, Eurofarad, Texas Instrument, Miteq, Cobham, E2V, MA-COM, Hittite, Mini-Circuits, General Dynamics и др.);

Помимо этого, одним из направлений компании «ЭлектроПласт» является направление «Источники питания». Мы предлагаем Вам помощь Конструкторского отдела:

- Подбор оптимального решения, техническое обоснование при выборе компонента;
- Подбор аналогов;
- Консультации по применению компонента;
- Поставка образцов и прототипов;
- Техническая поддержка проекта;
- Защита от снятия компонента с производства.



Как с нами связаться

Телефон: 8 (812) 309 58 32 (многоканальный)

Факс: 8 (812) 320-02-42

Электронная почта: org@eplast1.ru

Адрес: 198099, г. Санкт-Петербург, ул. Калинина, дом 2, корпус 4, литера А.