

## Application

- ✓ TV/Video, Audio, Home appliance, Precision apparatus, Automotive, Office equipment, Communication, Musical instruments, Industrial control, Others

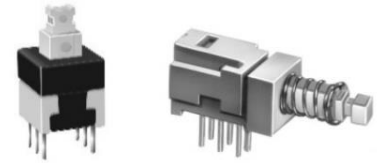

## Feature

- ✓ Small size push button switches with good feeling.

## ■Specification

Operating Temperature Range	-10 °C~70°C
Standard Contact Resistance	< 50 mΩ
Operating Life Cycle	10,000 cycles

## ■How to order

SP70018F - 0202 - 13F1 - N N - N

### Model

SP – Push Switch

### Number of Pole and Position

Ex. 0102 – 1 pole 2 positions  
0402 – 4 poles 2 positions

### Actuator

### Timing

Order Code	Description
N	Non-Shorting (break-before-make)
S	Shorting (make-before-break)

### Mechanical Configuration

Order Code	Description
N	Non-lock
Blank	Lock

### Plating of Casing



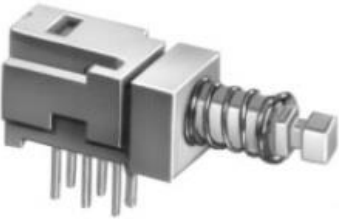
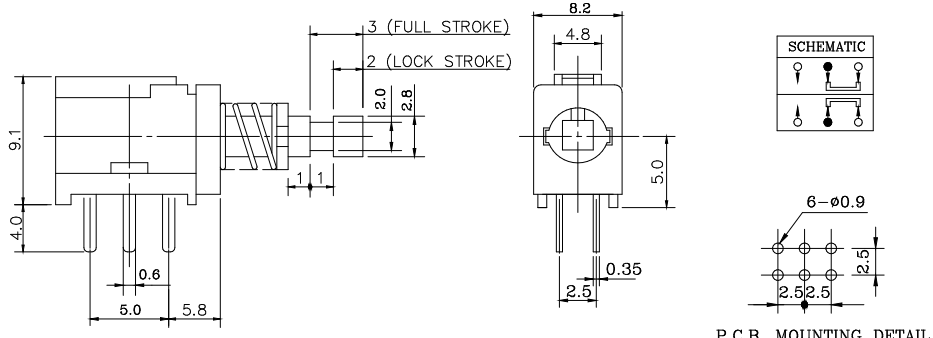

Order Code	Description
N	Nickel plated
Blank	Plastic case

## Model Description

Model	Pole / Position	Operation Force	Rating	Timing	Mechanical Configuration
<a href="#">SP70300F-0202</a>	2 poles, 2 positions	300±150gf.cm	DC30V, 0.1A	Non-Shorting	Lock /Non-lock
<a href="#">SP70300F-0402</a>	4 poles, 2 positions	300±150gf.cm	DC30V, 0.1A	Non-Shorting	Lock /Non-lock
<a href="#">SP70300F-0602</a>	6 poles, 2 positions	300±150gf.cm	DC30V, 0.1A	Non-Shorting	Lock /Non-lock
<a href="#">SP70018F-0202</a>	2 poles, 2 positions	300±150gf.cm	AC125V, 0.3A	Non-Shorting	Lock /Non-lock
<a href="#">SP70030F-0202</a>	2 poles, 2 positions	300±150gf.cm	AC125V, 0.3A	Non-Shorting / Shorting	Lock /Non-lock
<a href="#">SP80010F-0202</a>	2 poles, 2 positions	150±80gf.cm	DC30V, 0.1A	Non-Shorting	Lock /Non-lock
<a href="#">SP80050F-0202</a>	2 poles, 2 positions	200±80gf.cm	DC30V, 0.3A	Non-Shorting	Lock /Non-lock
<a href="#">SP8005BF-0202</a>	2 poles, 2 positions	200±80gf.cm	DC30V, 0.3A	Non-Shorting	Lock /Non-lock

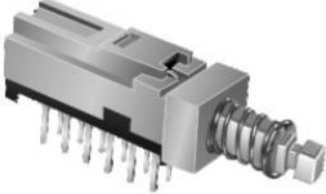
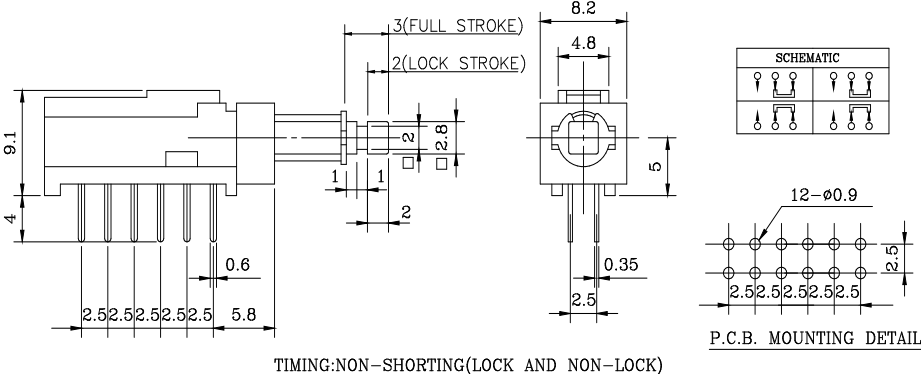
Order Code	Outline Drawing
SP70300F-0202-11F1-N SP70300F-0202-11F1-N-N	  <p>TIMING:NON-SHORTING(LOCK AND NON-LOCK)</p> <p>P.C.B. MOUNTING DETAIL</p>

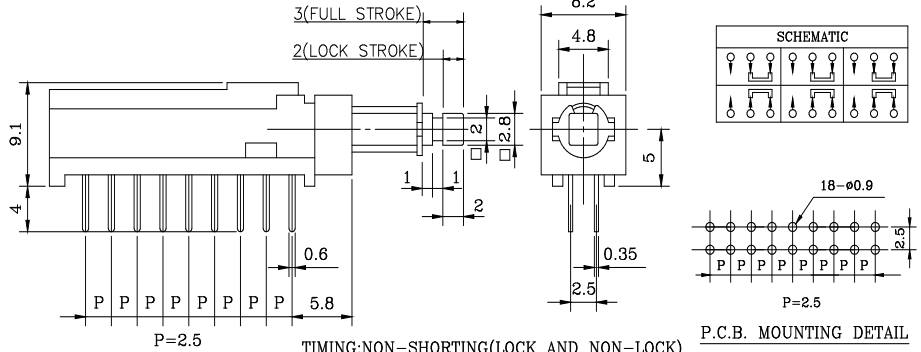
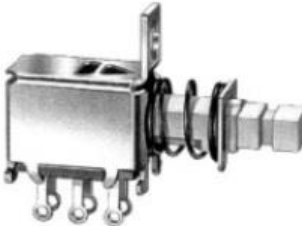
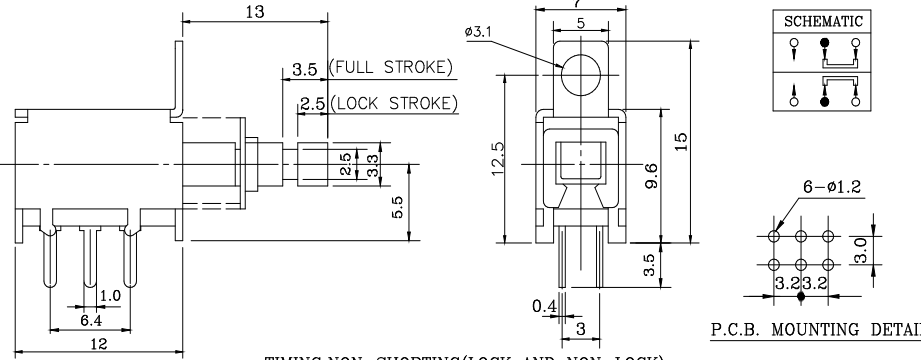

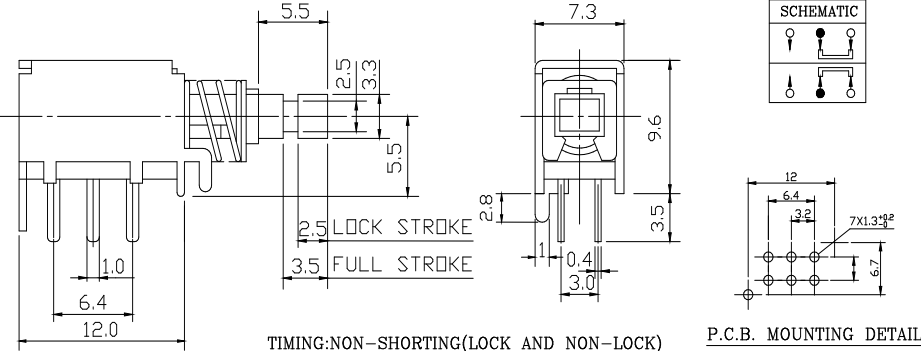

[Back to top](#)

Order Code	Outline Drawing
<p>SP70300F-0402-11F1-N SP70300F-0402-11F1-N-N</p> 	 <p>TIMING:NON-SHORTING(LOCK AND NON-LOCK)</p>
<p>SP70300F-0602-11F1-N SP70300F-0602-11F1-N-N</p> 	 <p>TIMING:NON-SHORTING(LOCK AND NON-LOCK)</p>
<p>SP70018F-0202-13F1-NN SP70018F-0202-13F1-NN-N</p> 	 <p>TIMING:NON-SHORTING(LOCK AND NON-LOCK)</p>
<p>SP70030F-0202-13F1-NN(-N) SP70030F-0202-13F1-SN(-N)</p> 	 <p>TIMING:NON-SHORTING(LOCK AND NON-LOCK) TIMING:SHORTING(LOCK AND NON-LOCK)</p>

[Back to top](#)

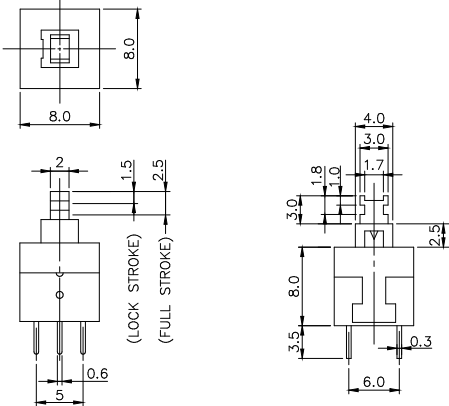
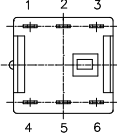
# PUSH SWITCH

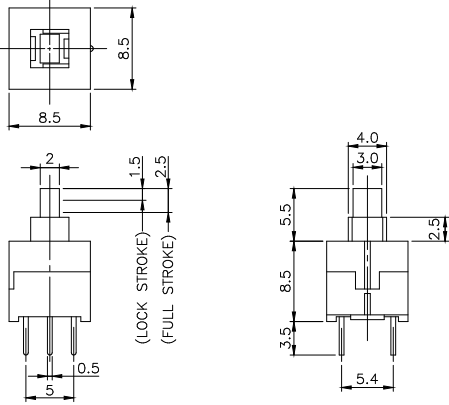
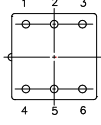
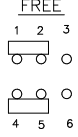
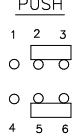

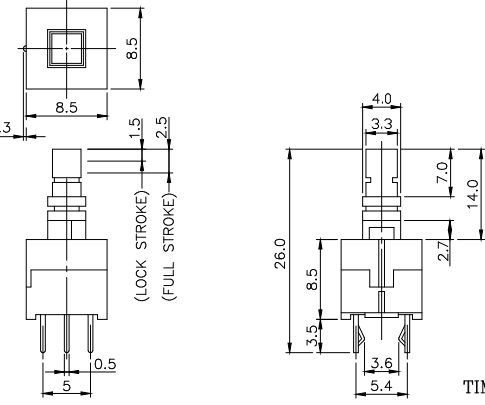
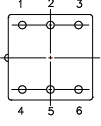
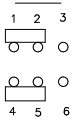
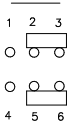
Order Code	Outline Drawing
<p>SP80010F-0202-10F5-N SP80010F-0202-10F5-N-N</p> 	  <p>PUSH 2-3 ON 4-5 ON</p> <p>FREE 1-3 ON 4-6 ON</p> <p>TIMING:NON-SHORTING(LOCK AND NON-LOCK)</p>
<p>SP80050F-0202-5.5F-N SP80050F-0202-5.5F-N-N</p> 	 <p>SCHMATIC</p>  <p>FREE</p>  <p>PUSH</p>  <p>TIMING:NON-SHORTING(LOCK AND NON-LOCK)</p>
<p>SP8005BF-0202-14F-N SP8005BF-0202-14F-N-N</p> 	 <p>SCHMATIC</p>  <p>FREE</p>  <p>PUSH</p>  <p>TIMING:NON-SHORTING(LOCK AND NON-LOCK)</p>

Design and specifications presented here are for the standard parts only. Please kindly contact us for your special requests and ask for the current technical specifications before purchase and/or use.

[Back to top](#)

# Mouser Electronics

Authorized Distributor

Click to View Pricing, Inventory, Delivery & Lifecycle Information:

[Alpha \(Taiwan\):](#)

[SP70030F-0202-13F1-01-NN](#)



Компания «ЭлектроПласт» предлагает заключение долгосрочных отношений при поставках импортных электронных компонентов на взаимовыгодных условиях!

Наши преимущества:

- Оперативные поставки широкого спектра электронных компонентов отечественного и импортного производства напрямую от производителей и с крупнейших мировых складов;
- Поставка более 17-ти миллионов наименований электронных компонентов;
- Поставка сложных, дефицитных, либо снятых с производства позиций;
- Оперативные сроки поставки под заказ (от 5 рабочих дней);
- Экспресс доставка в любую точку России;
- Техническая поддержка проекта, помощь в подборе аналогов, поставка прототипов;
- Система менеджмента качества сертифицирована по Международному стандарту ISO 9001;
- Лицензия ФСБ на осуществление работ с использованием сведений, составляющих государственную тайну;
- Поставка специализированных компонентов (Xilinx, Altera, Analog Devices, Intersil, Interpoint, Microsemi, Aeroflex, Peregrine, Syfer, Eurofarad, Texas Instrument, Miteq, Cobham, E2V, MA-COM, Hittite, Mini-Circuits, General Dynamics и др.);

Помимо этого, одним из направлений компании «ЭлектроПласт» является направление «Источники питания». Мы предлагаем Вам помощь Конструкторского отдела:

- Подбор оптимального решения, техническое обоснование при выборе компонента;
- Подбор аналогов;
- Консультации по применению компонента;
- Поставка образцов и прототипов;
- Техническая поддержка проекта;
- Защита от снятия компонента с производства.



#### Как с нами связаться

**Телефон:** 8 (812) 309 58 32 (многоканальный)

**Факс:** 8 (812) 320-02-42

**Электронная почта:** [org@eplast1.ru](mailto:org@eplast1.ru)

**Адрес:** 198099, г. Санкт-Петербург, ул. Калинина, дом 2, корпус 4, литера А.