



FEATURES

- Extended Power Range to 1300W
- 1.57" (1U) x 11.0" x 3.2"
- 92% efficiency at 50% FL
- 12VDC Main output
- 3.3VSB or 5VSB output (20W)
- >23W/in³ power density
- N+1 Redundancy Capable; hot plug/swap (up to 8 modules in parallel)
- Active current sharing on 12V main output; integral MOSFET ORING
- Over-Voltage, Over-Current; Over-Temperature Protection
- Internal variable speed cooling fans
- PMBus™ Power Management Bus
- RoHS Compliant



Available now at
www.murata-ps.com/en/3d/acdc.html

PRODUCT OVERVIEW

The D1U3CS-W-1300F-12-Hx4EC are high efficiency 1300W power factor corrected front end supplies with a 12V main output and a 5V or 3.3V (20W) standby. Active current sharing is provided to allow up to eight (8) supplies to be operated in parallel. The supplies may be hot plugged and include integral isolation devices.

The power modules are fully protected from overload and overvoltage and are able to auto-recover from overtemperature faults. Status LEDs are provided on the front panel and additional control and status reporting is provided by hardware logic signals and via a PMBus™ digital interface.

A low profile sub 1U height enclosure provides a power density of >23W/in³ that is ideal for delivering reliable, efficient power to servers, workstations, storage systems and other 12V distributed power systems.

ORDERING GUIDE

Model Number	Power Output		Main Output	Standby Output	Airflow
	AC Line & Temp (108-264V; 40°C)	AC Line & Temp (90-264V; 50°C)			
D1U3CS-W-1300F-12-HA4EC	1300W	1200W	12V	5V	Back to Front
D1U3CS-W-1300F-12-HC4EC				3.3V	

INPUT CHARACTERISTICS

Parameter	Conditions	Min	Typ	Max	Units
Voltage Operating Range		90	115/230	264	Vac
Input Frequency		47	50/60	63	Hz
Turn-on Input Voltage	Ramp Up	81	85	89	Vac
Turn-off Input Voltage	Ramp Down	70.5	74.3	78.0	
Maximum Current @ VIN = 200Vac	1300W @ 40°C (max)			8	Arms
Maximum Current @ VIN = 90Vac	1200W @ 50°C (max)			15	
Inrush Current	Cold start between 0 to 200ms			25	Apk
Power Factor	At 230Vac; FL		0.99		
Efficiency (230Vac) excluding fan load	20% FL	88			%
	50% FL	92			
	100% FL	92			

OUTPUT VOLTAGE CHARACTERISTICS

Output Voltage	Parameter	Conditions	Min	Typ	Max	Units
12V	Voltage Set Point Accuracy			12		Vdc
	Line & Load Regulation		11.4		12.6	
	Ripple & Noise ¹	20MHz Bandwidth			150	mV P-P
	Output Current (230Vac)		0		108.3	A
	Output Current (120Vac)				108.3	
	Output Current (90Vac)				100	
3.3VSB	Load Capacitance				30,000	µF
	Voltage Set Point			3.3		Vdc
	Line & Load Regulation		3.2		3.4	
	Ripple Voltage & Noise ¹	20MHz Bandwidth			100	mV P-P
5VSB	Output Current		0		6	A
	Load Capacitance				10,000	µF
	Voltage Set Point			5.0		Vdc
	Line & Load Regulation		4.85		5.1	
	Ripple Voltage & Noise ¹	20MHz Bandwidth			50	mV P-P
Output Current		0		4	A	
	Load Capacitance				10,000	µF

¹ Ripple and noise are measurements are to be performed with a parallel combination of a 0.1µF ceramic capacitor and 10µF tantalum capacitance on each of the power module output measurement nodes. A short coaxial cable shall be used.



OUTPUT CHARACTERISTICS					
Parameter	Conditions	Min	Typ	Max	Units
Remote Sense	Compensation at full load (total loop for positive & negative connections)			120	mV
Output Rise (Monotonic)	10% to 95% rise time	No voltage excursion			
Startup Time	AC Ramp Up		1.5	2.5	s
	PS_ON activation		150		ms
Transient Response	12V, 50-100% step load 1A/μs		600		mV
	3.3/5VSB 50-100% step load 1A/μs		165/250		
Current Sharing Accuracy (up to 8 in parallel)	At 100% load			±7	%
Hot Swap Transients				5	%
Hold Up Time	FL (Full Load)	12			ms

ENVIRONMENTAL CHARACTERISTICS					
Parameter	Conditions	Min	Typ	Max	Units
Storage Temperature Range	Non-Condensing	-40		70	°C
Operating Temperature Range	1200W	0		50	
	1300W	0		40	
Operating Humidity	Non-Condensing	5		90	%
Storage Humidity		5		95	
Altitude (no derating at 40°C)		3000			m
Shock	Operating			30	G
Sinusoidal Vibration	Operational, 2.0G; 5-500Hz				
MTBF	Telcordia SR-332 M1C1 @ 40°C	500			K Hours
Safety Approvals (Standards)	CSA/UL C22.2 No.60950-1-07, Amendment 1_2011 ANSI/UL 60950-1-2011 IEC 60950-1:2005, (2 nd Edition) + A1:2009 EN 60950-1:2006 + A11:2009 +A1 :2010 +A12:2011 CE Marking per LVD DIRECTIVE 2006/95/ECS				
Input Fusing	Internal 16A/250V rated fast blow in AC line				
Switching Frequency	90KHz for the PFC Boost Converter 130KHZ for the Main Output Converter				
Material Flammability	UL94-V0				
Weight				3.15/1.43	Lbs/kg

PROTECTION CHARACTERISTICS						
Output Voltage	Parameter	Conditions	Min.	Typ.	Max.	Units
N/A	Over-Temperature	Auto re-start	57	60	63	°C
	Over-Voltage	Latching	13.3		14.5	V
12V (Main)	Over-Current (1300W)	Latching	115		125	A
	Over-Current (1200W)	Latching	108		118	
3.3VSB	Over-Voltage	Latching	3.9		4.3	V
	Over-Current	Auto-recovery	6.5		9.0	A
5VSB	Over-Voltage	Latching	5.6		6.0	V
	Over-Current	Auto-recovery	5.0		6.5	A

ISOLATION CHARACTERISTICS					
Parameter	Conditions	Min.	Typ.	Max.	Units
Insulation Safety Rating/Test Voltage	Input to Output – Re-enforced	3000			Vrms
	Input to Chassis - Basic	1500			Vrms
Isolation	Output to Chassis (Ground)	500			Vdc

STATUS INDICATORS

Conditions	LED Status
Standby Rail ON; Main Output OFF; AC Present & correct	Blinking Green
Standby Rail ON; Main Output ON	Solid Green
Main Output overcurrent; undervoltage, overvoltage warning	Blinking Amber
FAN_FAULT; overtemperature; standby rail overcurrent, Main Output overcurrent or overvoltage	Red

EMISSIONS AND IMMUNITY

Characteristic	Standard	Compliance
Input Current Harmonics	IEC/EN 61000-3-2	Complies with Class A Limits
Voltage Fluctuation & Flicker	IEC/EN 61000-3-3	Complies
Conducted Emissions	FCC 47 CFR Part 15 CSIPR 22/EN55022	Class B
ESD Immunity	IEC/EN 61000-4-2;	Level 3; Criteria A
Radiated Field Immunity	IEC/EN 61000-4-3	Level 3; Criteria B
Electrical Fast Transients/Burst Immunity	IEC/EN 61000-4-4	Level 3; Criteria B
Surge Immunity	IEC/EN 61000-4-5	Level 3; Criteria A
RF Conducted Immunity	IEC/EN 61000-4-6	Level 3; Criteria A
Magnetic Field Immunity	IEC/EN 61000-4-8	3A/m; Criteria B
Voltage Dips & Interruptions	IEC/EN 61000-4-11	230V _{in} , 100% load, Phase 0°, Dip 100% Duration 10ms (A) 230V _{in} , 50% load, Phase 0°, Dip 100% Duration 20ms (VSB:A, V1:A) 230V _{in} , 100% load, Phase 0°, Dip 100% Duration > 12ms (VSB:A, V1:B)

OUTPUT CONNECTOR & SIGNAL INTERFACE

DC Output and Signal Connector: FCI# 51731-057-LF

D1	D2	D3	D4	D5	D6						
C1	C2	C3	C4	C5	C6	PB1	PB2	PB3	PB4	PB5	PB6
B1	B2	B3	B4	B5	B6						
A1	A2	A3	A4	A5	A6						

NB: B4 is the shortest "last make, first break" sequenced signal pin

Blade Assignment	Function	Description	Current (Amps per Pin)
PB1, PB2, PB3	+12V GND	Main Output Voltage, Return	30
PB4, PB5, PB6	+12V OUT	Main Output Voltage	30
Signal Pin Assignment	Signal Name	Description	
A1	PS_ON_L	An input pulled up via an internal 10K ohm to the Standby rail. When pulled low (via an open collector/drain drive or connection to GND) the Main Output will be turned on/enabled)	N/A
A2	+12VRS_RETURN	Main Output Remote Sense (-VE/Return)	N/A
A3	TEMP_OK	TTL compatible Logic HIGH provided when the temperature is within the allowable range of operation.	
A4	PS_SEATED	Internally connected to GND; when the power module is correctly seated the corresponding mating connector pin is grounded and therefore allows detection that the power module is in situ.	N/A
A5, B5, C5, D5	+VSB	Standby Voltage Output	2.0
A6, B6, C6, D6	+VSB GND	Standby Voltage Output, Return/GND	2.0
B1	AC_OK	Incoming AC Source voltage "OK" (present and within operational limits)	N/A
B2	+12VRS	Main 12V output remote sense line	N/A
B3	+12V_ISHARE	Main 12V output current share bus	N/A
B4	PS_INHIBIT/PS_KILL	This is the shortest "last make, first break" (last to mate in the sequence). If left open circuit then the main output will be inhibited (no output). When inserted in to the system slot this pin must be pulled "low" by the system to enable (turn on) the Main output and only after all other pins are connected and the power module is correctly seated.	N/A
C1	SDA	I ² C Serial Data Line	N/A
C2	SCL	I ² C Serial Clock Line	N/A

Signal Pin Assignment	Signal Name	Description	Current (Amps per Pin)
C3	PWR_GD	Power Good signal. An active TTL HIGH signifies when the output is within regulation limits.	N/A
C4	FAN_FAIL	Fan Fail signal (failure or locked rotor)	N/A
D1	A0	I ² C LSB (Least Significant Bit) Address Line	N/A
D2	A1	I ² C MSB (Most Significant Bit) Address Line	N/A
D3	S_INT	System Interrupt	N/A
D4	N/A	Reserved; no end user connection	N/A

MATING CONNECTOR

Supplier	Press Fit, Straight	Press Fit, Right Angle	Solder Straight	Solder Right Angle
FCI	---	51761-10002406AA	---	---

WIRING DIAGRAM FOR OUTPUT

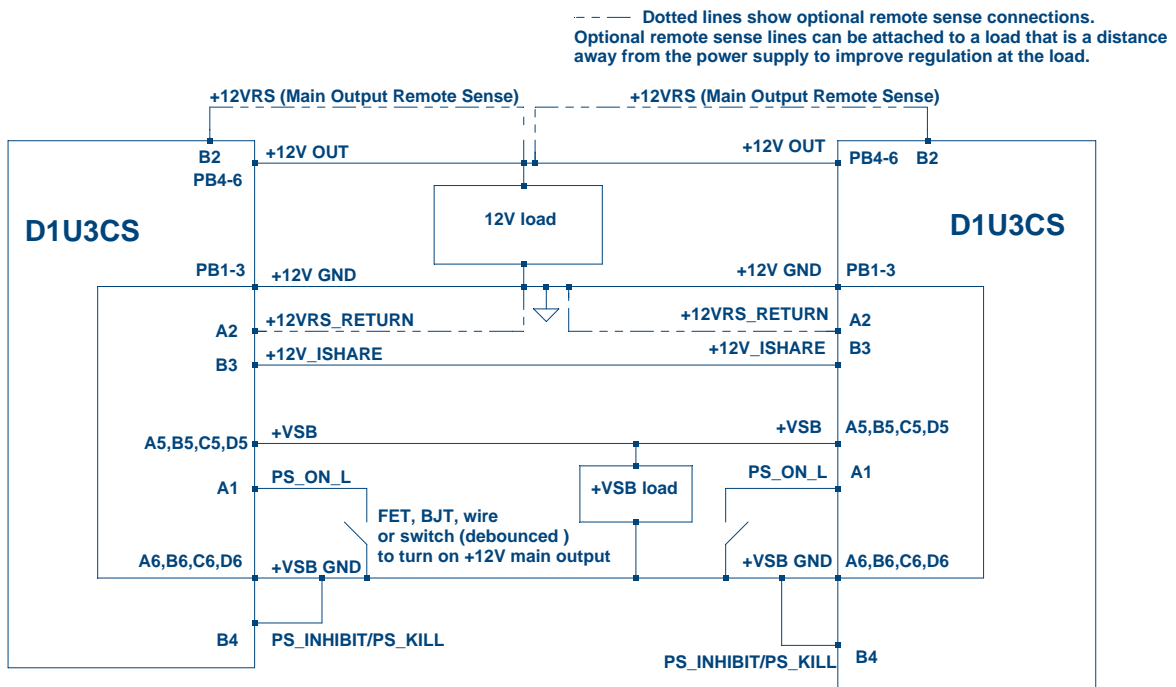

CURRENT SHARING NOTES

1. Main 12VDC Output: Analogue active share bus. The ISHARE bus (Pin B3) must be connected on all sharing modules. It is not required that the SENSE signals are connected to the remote load for current share to operate correctly.
2. Up to eight (8) power modules can be connected in parallel (non-redundant) or N+1 configuration. The current share bus is analogue bi-directional (can source or sink current from the ISHARE bus). The voltage of the bus would measure 8VDC for a single power module at 100% load; for two (2) modules sharing a common load the ISHARE bus voltage would be 4V for a perfect 50/50 current share scenario.
3. VSTANDBY output power modules can also be connected in parallel and have internal output isolation devices; however the combined available power is limited to that available from a single power module (3.3V or 5V; 20W) irrespective of the number of modules connected in parallel.

MECHANICAL DIMENSIONS

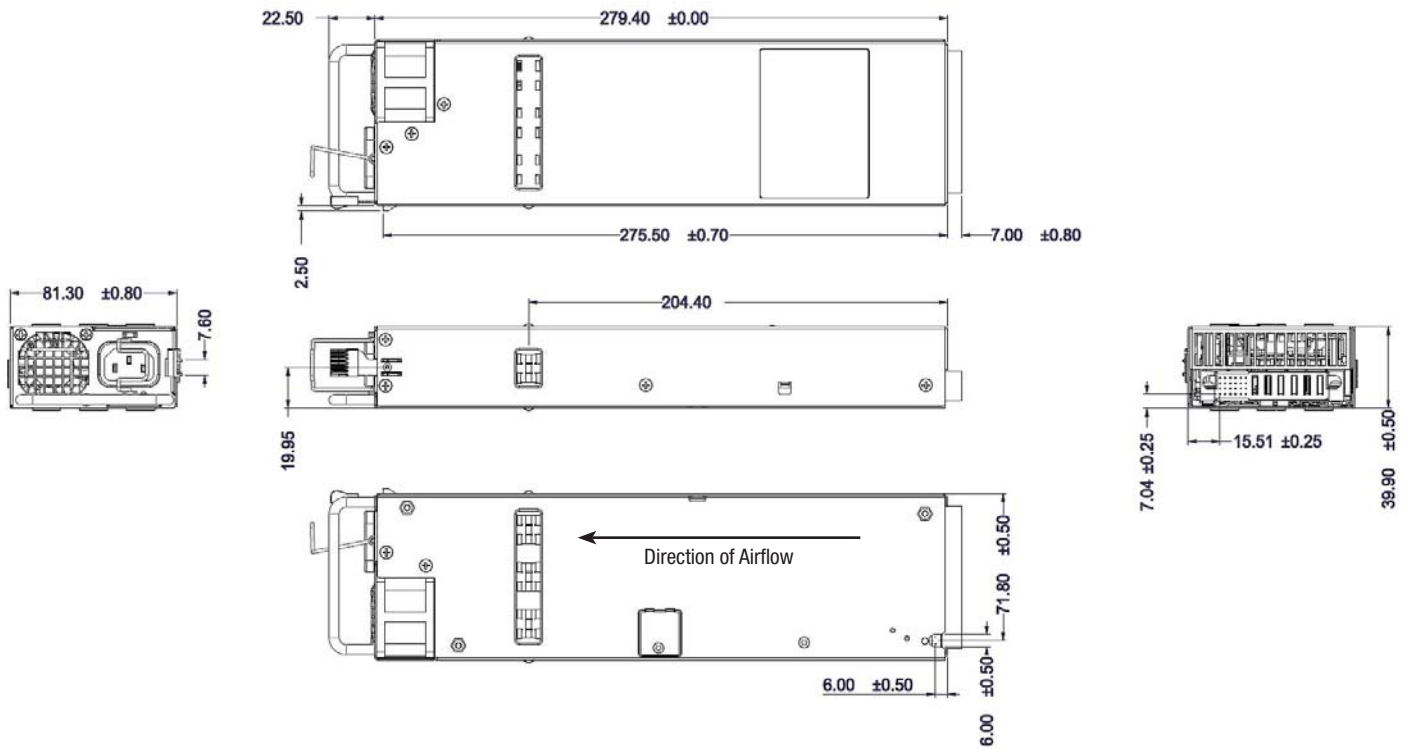

AC Input Connector/Inlet: IEC 60320-C14

Dimensions: 3.20" x 11.00" x 1.57" [81.3mm x 279.4mm x 39.9mm]

OPTIONAL ACCESSORIES

Description	Part Number
D1U3CS-12 Output Interface Connector Card	D1U3CS-12-CONC

APPLICATION NOTES

Document Number	Description	Link
ACAN-41	D1U3CS-12-CONC Output Interface Connector Card	www.murata-ps.com/data/apnotes/acan-41.pdf
ACAN-49	D1U3CS-12 Communications Protocol	www.murata-ps.com/data/apnotes/acan-49.pdf

Murata Power Solutions, Inc.
 11 Cabot Boulevard, Mansfield, MA 02048-1151 U.S.A.
 ISO 9001 and 14001 REGISTERED



This product is subject to the following operating requirements and the Life and Safety Critical Application Sales Policy:
 Refer to: <http://www.murata-ps.com/requirements/>

Murata Power Solutions, Inc. makes no representation that the use of its products in the circuits described herein, or the use of other technical information contained herein, will not infringe upon existing or future patent rights. The descriptions contained herein do not imply the granting of licenses to make, use, or sell equipment constructed in accordance therewith. Specifications are subject to change without notice. © 2014 Murata Power Solutions, Inc.



Компания «ЭлектроПласт» предлагает заключение долгосрочных отношений при поставках импортных электронных компонентов на взаимовыгодных условиях!

Наши преимущества:

- Оперативные поставки широкого спектра электронных компонентов отечественного и импортного производства напрямую от производителей и с крупнейших мировых складов;
- Поставка более 17-ти миллионов наименований электронных компонентов;
- Поставка сложных, дефицитных, либо снятых с производства позиций;
- Оперативные сроки поставки под заказ (от 5 рабочих дней);
- Экспресс доставка в любую точку России;
- Техническая поддержка проекта, помощь в подборе аналогов, поставка прототипов;
- Система менеджмента качества сертифицирована по Международному стандарту ISO 9001;
- Лицензия ФСБ на осуществление работ с использованием сведений, составляющих государственную тайну;
- Поставка специализированных компонентов (Xilinx, Altera, Analog Devices, Intersil, Interpoint, Microsemi, Aeroflex, Peregrine, Syfer, Eurofarad, Texas Instrument, Miteq, Cobham, E2V, MA-COM, Hittite, Mini-Circuits, General Dynamics и др.);

Помимо этого, одним из направлений компании «ЭлектроПласт» является направление «Источники питания». Мы предлагаем Вам помощь Конструкторского отдела:

- Подбор оптимального решения, техническое обоснование при выборе компонента;
- Подбор аналогов;
- Консультации по применению компонента;
- Поставка образцов и прототипов;
- Техническая поддержка проекта;
- Защита от снятия компонента с производства.



Как с нами связаться

Телефон: 8 (812) 309 58 32 (многоканальный)

Факс: 8 (812) 320-02-42

Электронная почта: org@eplast1.ru

Адрес: 198099, г. Санкт-Петербург, ул. Калинина, дом 2, корпус 4, литера А.