

MCR-SL-CUC-...-...

Universal current transducer

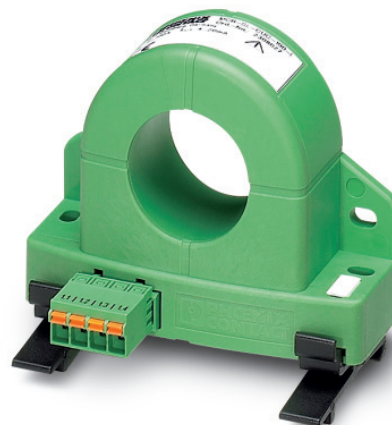

Data sheet
104059_en_05

© PHOENIX CONTACT 2011-03-09

1 Description

MCR-SL-CUC-...-I and **MCR-SL-CUC-...-U** active current transducers convert DC, AC, and distorted currents into standard analog signals.

Output signal: 4 ... 20 mA.

Designation	Input current	Order No.
MCR-SL-CUC-100-I	0 ... 100 A	2308027
MCR-SL-CUC-200-I	0 ... 200 A	2308030
MCR-SL-CUC-300-I	0 ... 300 A	2308043
MCR-SL-CUC-400-I	0 ... 400 A	2308072
MCR-SL-CUC-500-I	0 ... 500 A	2308085
MCR-SL-CUC-600-I	0 ... 600 A	2308098

Output signal: 0 ... 10 V

Designation	Input current	Order No.
MCR-SL-CUC-100-U	0 ... 100 A	2308108
MCR-SL-CUC-200-U	0 ... 200 A	2308205
MCR-SL-CUC-300-U	0 ... 300 A	2308302

Features

- Electrical isolation of input and output signals
- Contact-free measurement of live conductors
- Large input signal opening



Make sure you always use the latest documentation.
It can be downloaded at www.phoenixcontact.net/catalog.



This data sheet is valid for all products listed on the following page:

2 Table of contents

1	Description.....	1
2	Table of contents	2
3	Ordering data.....	3
4	Technical data	3
5	Safety notes and warning instructions	5
6	Block diagram.....	6
7	Structure	6
8	Mounting.....	6
9	Installation	7
	9.1 Power supply.....	7
	9.2 Connecting the cables.....	7
10	Current monitoring	7

3 Ordering data

Products

Description	Type	Order No.	Pcs./Pkt.
Universal current transducer for measuring DC, AC, and distorted currents, 0 ... 100 A input current, 4 ... 20 mA output current	MCR-SL-CUC-100-I	2308027	1
Universal current transducer for measuring DC, AC, and distorted currents, 0 ... 200 A input current, 4 ... 20 mA output current	MCR-SL-CUC-200-I	2308030	1
Universal current transducer for measuring DC, AC, and distorted currents, 0 ... 300 A input current, 4 ... 20 mA output current	MCR-SL-CUC-300-I	2308043	1
Universal current transducer for measuring DC, AC, and distorted currents, 0 ... 400 A input current, 4 ... 20 mA output current	MCR-SL-CUC-400-I	2308072	1
Universal current transducer for measuring DC, AC, and distorted currents, 0 ... 500 A input current, 4 ... 20 mA output current	MCR-SL-CUC-500-I	2308085	1
Universal current transducer for measuring DC, AC, and distorted currents, 0 ... 600 A input current, 4 ... 20 mA output current	MCR-SL-CUC-600-I	2308098	1
Universal current transducer for measuring DC, AC, and distorted currents, 0 ... 100 A input current, 0 ... 10 V output voltage	MCR-SL-CUC-100-U	2308108	1
Universal current transducer for measuring DC, AC, and distorted currents, 0 ... 200 A input current, 0 ... 10 V output voltage	MCR-SL-CUC-200-U	2308205	1
Universal current transducer for measuring DC, AC, and distorted currents, 0 ... 300 A input current, 0 ... 10 V output voltage	MCR-SL-CUC-300-U	2308302	1

Accessories

Description	Type	Order No.	Pcs./Pkt.
Flat zack marker strip marking material (without color print, white)	ZBF10:UNBEDRUCKT	0044187	1
DIN rail adapter for mounting the universal current transducer	PACT MCR-RA	2277598	12

4 Technical data

Input	MCR-SL-CUC-100-I	MCR-SL-CUC-200-I	MCR-SL-CUC-300-I
Nominal input current I_{IN}	0 ... 100 A	0 ... 200 A	0 ... 300 A
Overload capacity	6 x I_{IN} , maximum	3 x I_{IN} , maximum	3.33 x I_{IN} , maximum
	MCR-SL-CUC-400-I	MCR-SL-CUC-500-I	MCR-SL-CUC-600-I
Nominal input current I_{IN}	0 ... 400 A	0 ... 500 A	0 ... 600 A
Overload capacity	2.5 x I_{IN} , maximum	3.6 x I_{IN} , maximum	3 x I_{IN} , maximum
	MCR-SL-CUC-100-U	MCR-SL-CUC-200-U	MCR-SL-CUC-300-U
Nominal input current I_{IN}	0 ... 100 A	0 ... 200 A	0 ... 300 A
Overload capacity	6 x I_{IN} , maximum	3 x I_{IN} , maximum	3.33 x I_{IN} , maximum
Frequency range	DC, 20 ... 6000 Hz		
Signal form	Any		
Connection method	Through connection of 32 mm \varnothing		
Output	MCR-SL-CUC-...-I	MCR-SL-CUC-...-U	
Output signal I_{OUT}	4 ... 20 mA	0 ... 10 V	
Maximum output signal	< 25 mA	< 14 V	
Load	< 300 Ω	≥ 10 k Ω	
Connection method	FKCN 2.5/ 4-ST COMBICON connector		

Connection data

Outside diameter of input	32 mm Ø
Power supply/output conductor cross-section	
Solid (minimum/maximum)	0.2 ... 2.5 mm ²
Stranded (minimum/maximum)	0.2 ... 2.5 mm ²
Stranded with ferrule without plastic sleeve (minimum/maximum)	0.25 ... 2.5 mm ²
Stranded with ferrule with plastic sleeve (minimum/maximum)	0.25 ... 1.5 mm ²
AWG/kcmil (minimum/maximum)	24 ... 14
Stripping length (power supply/output)	10 mm

General data

Supply voltage	24 V DC
Supply voltage range U_B	20 ... 30 V DC
Current consumption	
MCR-SL-CUC-...-I	30 mA + I_{OUT}
MCR-SL-CUC-...-U	30 mA
Power consumption	
At $U_{Bmax} = 30$ V and $I_{OUT} = 25$ mA	1.65 W
Transmission error	
Under nominal conditions (25°C)	< ±1% of range final value (I_N)
Linearity error	< ±1% of range final value (I_N)
Temperature coefficient	
0 ... 60°C	±3.2 µA/K
-40 ... 65°C	±6.4 µA/K
Step response (90% of I_N)	150 ms
Ambient temperature range	
Operation	-40°C ... +65°C
Storage	-40°C ... +85°C
Safe isolation according to EN 61010	
Rated insulation voltage	300 V AC
Test voltage	
Input/output	3.5 kV, 50 Hz, 1 min.
Input/power supply	3.5 kV, 50 Hz, 1 min.
Surge voltage category (measurement category according to EN 61010)	III
Pollution degree	2
Degree of protection	IP20
Dimensions (W x H x D)	90 mm x 70 mm x 33.8 mm
Housing version	Frianyl B63 V0 GV30



The current transducer housing meets the requirements of UL94-V0 regarding inflammability characteristics.

Approvals

UL, USA / Canada



(does not apply to 2308085, 2308098)

Conformance with EMC Directive 2004/108/EC and Low Voltage Directive 2006/95/EC

EMC requirements regarding noise immunity and noise emission	EN 61326-1:2006
General requirements regarding electrical safety	EN 61010-1:2001

Dimensions (nominal sizes in mm)

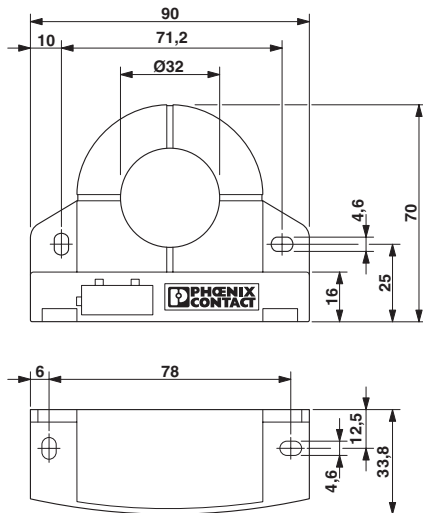

5 Safety notes and warning instructions



Installation and startup must only be carried out by qualified electricians. When installing and operating the device, the applicable safety directives (including national safety directives), accident prevention regulations, as well as general technical regulations, must be observed. In terms of these operating instructions, qualified personnel are electricians or persons with electrotechnical training as defined in VDE 0105 Part 1/DIN EN 50110-1.



WARNING:

Disregarding this warning may result in damage to equipment and/or serious personal injury.



NOTE:

Safe and error-free operation of this device can only be ensured if transport, storage, and assembly are carried out correctly and operation and maintenance are carried out with care.

6 Block diagram

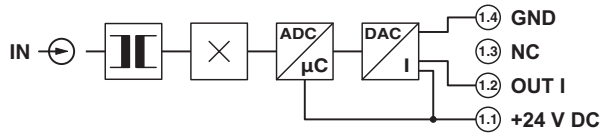

Figure 1 Block diagram for current output

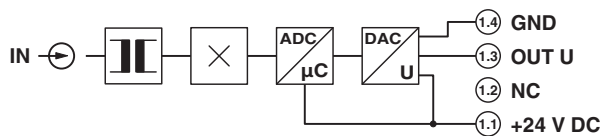

Figure 2 Block diagram for voltage output

7 Structure

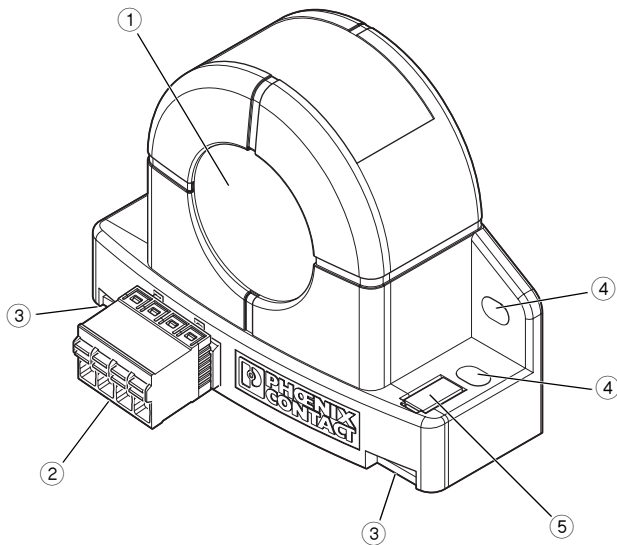

Figure 3 Structure

1. Input cable feed-through for the primary live conductor
2. Standard output signal and supply voltage (FKCN 2,5/ 4-ST COMBICON connector)
3. Connection option for DIN rail adapter
4. Fixing holes for wall mounting, \varnothing 4.5 mm
5. Marking option with flat zack marker strips

8 Mounting

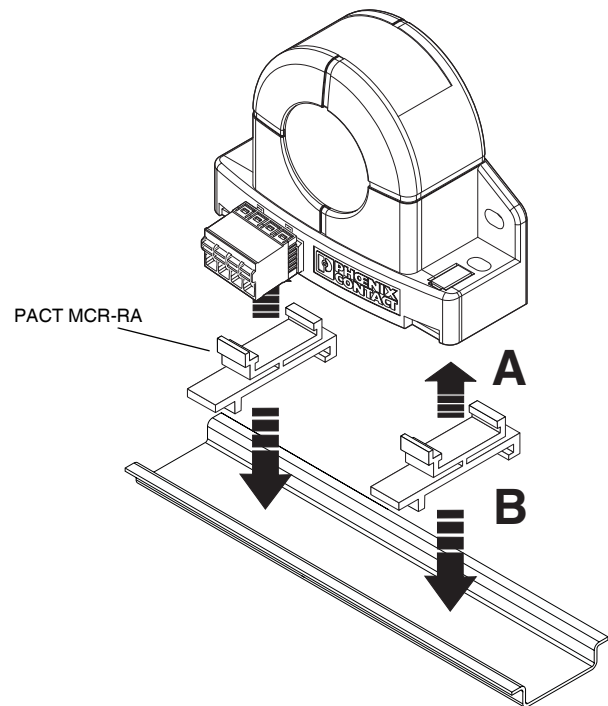

Figure 4 Mounting

The current transducers can be snapped onto all 35 mm DIN rails according to EN 60715 using the two PACT MCR-RA DIN rail adapters provided.

Alternatively, the current transducers can also be wall-mounted using the fixing holes (see Figure 3, "Structure").

Please use appropriate mounting material for this (e.g., M4 x 20 cylinder head screw).



Mounting material for wall mounting is not supplied as standard.



The requirements for the protection class must be met by means of installation in suitable housing.

9 Installation

9.1 Power supply



WARNING: Danger

Never carry out work when mains voltage is present.

Power supply via the connection terminal blocks

Power is supplied to the current transducers via connection terminal blocks 1.1 and 1.4 (see Section 6 "Block diagram", Figure 1).

9.2 Connecting the cables

Spring-cage connection

The supply voltage and standard output signal are connected using the spring-cage connection method.

:

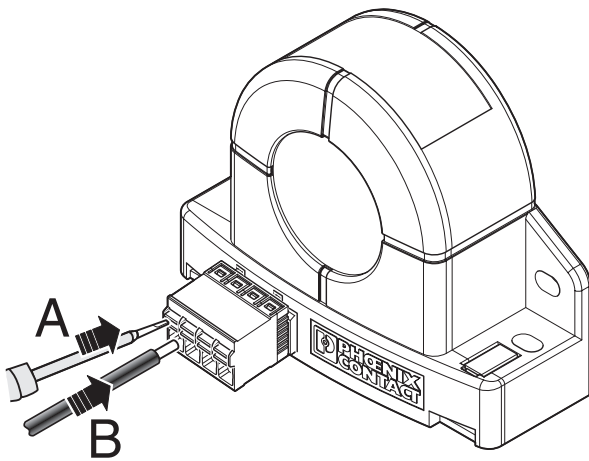

Figure 5 Spring-cage connection

- Insert a screwdriver into the opening above the connection terminal block.
- Insert the wire into the corresponding connection terminal block.

10 Current monitoring

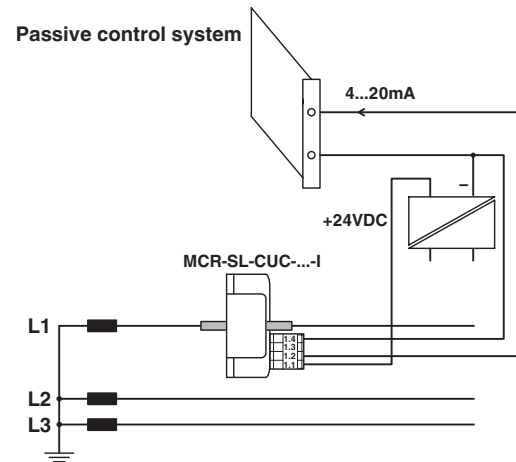

Figure 6 Current monitoring



Компания «ЭлектроПласт» предлагает заключение долгосрочных отношений при поставках импортных электронных компонентов на взаимовыгодных условиях!

Наши преимущества:

- Оперативные поставки широкого спектра электронных компонентов отечественного и импортного производства напрямую от производителей и с крупнейших мировых складов;
- Поставка более 17-ти миллионов наименований электронных компонентов;
- Поставка сложных, дефицитных, либо снятых с производства позиций;
- Оперативные сроки поставки под заказ (от 5 рабочих дней);
- Экспресс доставка в любую точку России;
- Техническая поддержка проекта, помощь в подборе аналогов, поставка прототипов;
- Система менеджмента качества сертифицирована по Международному стандарту ISO 9001;
- Лицензия ФСБ на осуществление работ с использованием сведений, составляющих государственную тайну;
- Поставка специализированных компонентов (Xilinx, Altera, Analog Devices, Intersil, Interpoint, Microsemi, Aeroflex, Peregrine, Syfer, Eurofarad, Texas Instrument, Miteq, Cobham, E2V, MA-COM, Hittite, Mini-Circuits, General Dynamics и др.);

Помимо этого, одним из направлений компании «ЭлектроПласт» является направление «Источники питания». Мы предлагаем Вам помощь Конструкторского отдела:

- Подбор оптимального решения, техническое обоснование при выборе компонента;
- Подбор аналогов;
- Консультации по применению компонента;
- Поставка образцов и прототипов;
- Техническая поддержка проекта;
- Защита от снятия компонента с производства.



Как с нами связаться

Телефон: 8 (812) 309 58 32 (многоканальный)

Факс: 8 (812) 320-02-42

Электронная почта: org@eplast1.ru

Адрес: 198099, г. Санкт-Петербург, ул. Калинина, дом 2, корпус 4, литера А.