

Description

Compact single pole thermal circuit breaker with push-to-reset, tease free, trip free, snap action mechanism and separate (colour coded) manual release. Combining full feature circuit breaker protection and convenience with low cost of ownership benefits. Fitted with blade terminals for plug-in mounting.

Type III to SAE J 553.

Version 1176 is available especially for the automotive industry (current ratings correspond to those of blade fuses).

Typical applications

Extra low voltage wiring systems on all types of vehicles and marine craft.

Ordering information

Type No.

1170 plug-in

Design standard

21 blade terminals for automotive fuse blocks (standard) with retaining clips, to DIN 72581, part 3

22 blade terminals for automotive fuse blocks, without retaining clips, to DIN 72581, part 3

Current ratings

3...25 A

1170 - 21 - 15 A ordering example

Please be informed that we have minimum ordering quantities to be observed.

Preferred types

Preferred types	Standard current ratings (A)										
	3	4	5	6	7.5	8	10	15	20	25	
1170-21-	x	x	x	x	x	x	x	x	x	x	x
1170-22-	x	x	x	x	x	x	x	x	x	x	x

Standard current ratings, typical voltage drop values and actuator colours (manual release)

Current rating (A)	Voltage drop (mV)	Actuator colour
3	< 300	violet
4	< 300	pink
5	< 300	light brown
6	< 150	mossy-green
7.5	< 150	brown
8	< 150	honey
10	< 150	red
15	< 150	blue
20	< 150	yellow
25	< 150	white



1170-...

Technical data

For further details please see: www.e-t-a.de/ti_e

Voltage rating (U_N)	DC 12 V / 24 V / 48 V				
Max. voltage (U_{smax})	DC 58 V				
Current ratings	3...25 A				
Typical life	at rated current:				
	U_N DC 24 V	3...25 A	6 000 operations	at $1 \times I_N$	
	U_N DC 24 V	3...20 A	3 000 operations	at $2 \times I_N$	
	U_N DC 24 V	25 A	1 000 operations	at $2 \times I_N$	
	U_N DC 48 V	3...25 A	500 operations	at $1 \times I_N$	
Ambient temperature	-40...85 °C (-40...+185 °F)				
Interrupting capacity I_{cn} to ISO10924	I_N	3...10 A	15 A	20 A	25 A
	U_N DC 24 V	400 A (0-C0-C0)			
	U_N DC 48 V	>100x at 75 A	>100x at 100 A	>100x at 135 A	>10x at 200 A
Absolute breaking capacity to ISO 10924	≥ 1 break operation at 2 000 A (L/R = 2,5 ms)				
Degree of protection (IEC 60529)	operating area IP40 terminal area IP00				
Vibration	10 g (57-500 Hz) ± 0.76 mm (10-57 Hz), to IEC 60068-2-6, test Fc, 10 frequency cycles/axis				
Shock	50 g (11 ms), to IEC 60068-2-27, test Ea				
Corrosion	96 hours at 5 % salt mist, to IEC 60068-2-11, test Ka				
Humidity	240 hours at 95 % RH to IEC 60068-2-78, test Cab				
Mass	approx. 10 g				

Dimensions

1170-21



1170-22



Internal connection diagram

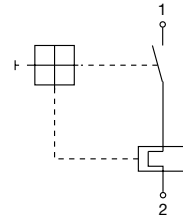

Typical time/current characteristics at +23°C/73.4°F

3...25 A



The time/current characteristic curve depends on the ambient temperature prevailing. In order to eliminate nuisance tripping, please multiply the circuit breaker current ratings by the derating factor shown below. See also section Technical information.

Ambient temperature °F	-40	-22	-4	+14	+32	+50
Ambient temperature °C	-40	-30	-20	-10	0	+10
Derating factor	0,77	0,80	0,84	0,89	0,94	0,96
Ambient temperature °F	+73.4	+104	+122	+140	+158	+185
Ambient temperature °C	+23	+40	+50	+60	+70	+85
Derating factor	1	1,08	1,16	1,24	1,33	1,42

This is a metric design and millimeter dimensions take precedence ($\frac{\text{mm}}{\text{inch}}$)

Accessories

Socket 12-P10



Socket 12-J20



Socket 12-A10

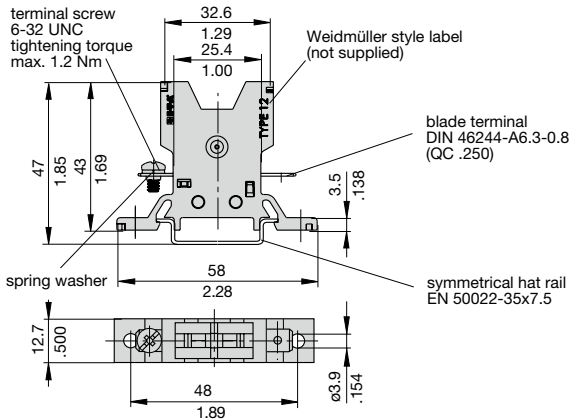

Dimensions for surface mounting



Other sockets available to special order
Labels: Weidmüller, D-33102 Paderborn

Ordering information Mounting socket 12

Type No.

12	Mounting socket
Terminal design	
P10	blade terminals A6.3-0.8 (QC .250)
J20	screw terminals 6-32 UNC
A10	1 blade terminal A6.3-0.8 (QC .250)/1 screw terminal 6-32 UNC
Version	
(blank)	single socket
20	two-way
30	three-way
40	four-way
60	six-way
12 - P10 - 20	ordering example

Accessories for mounting socket 12

Connector bus links -P10

- X 210 588 01/** 1.5 mm² (AWG 16), brown (up to 13 A max. load)
- X 210 588 02/** 2.5 mm² (AWG 14), black (up to 20 A max. load)
- X 210 588 03/** 2.5 mm² (AWG 14), red (up to 20 A max. load)
- X 210 588 04/** 2.5 mm² (AWG 14), blue (up to 20 A max. load)

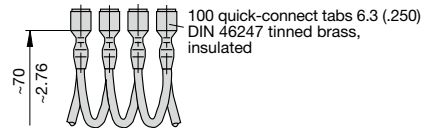

Bus bar (supplied as a complete package)
 (up to 100 A max. load)

- X 211 157 01** with terminal
- X 211 157 02** without terminal



This is a metric design and millimeter dimensions take precedence ($\frac{\text{mm}}{\text{inch}}$)

All dimensions without tolerances are for reference only. In the interest of improved design, performance and cost effectiveness the right to make changes in these specifications without notice is reserved. Product markings may not be exactly as the ordering codes. Errors and omissions excepted.





Компания «ЭлектроПласт» предлагает заключение долгосрочных отношений при поставках импортных электронных компонентов на взаимовыгодных условиях!

Наши преимущества:

- Оперативные поставки широкого спектра электронных компонентов отечественного и импортного производства напрямую от производителей и с крупнейших мировых складов;
- Поставка более 17-ти миллионов наименований электронных компонентов;
- Поставка сложных, дефицитных, либо снятых с производства позиций;
- Оперативные сроки поставки под заказ (от 5 рабочих дней);
- Экспресс доставка в любую точку России;
- Техническая поддержка проекта, помощь в подборе аналогов, поставка прототипов;
- Система менеджмента качества сертифицирована по Международному стандарту ISO 9001;
- Лицензия ФСБ на осуществление работ с использованием сведений, составляющих государственную тайну;
- Поставка специализированных компонентов (Xilinx, Altera, Analog Devices, Intersil, Interpoint, Microsemi, Aeroflex, Peregrine, Syfer, Eurofarad, Texas Instrument, Miteq, Cobham, E2V, MA-COM, Hittite, Mini-Circuits, General Dynamics и др.);

Помимо этого, одним из направлений компании «ЭлектроПласт» является направление «Источники питания». Мы предлагаем Вам помощь Конструкторского отдела:

- Подбор оптимального решения, техническое обоснование при выборе компонента;
- Подбор аналогов;
- Консультации по применению компонента;
- Поставка образцов и прототипов;
- Техническая поддержка проекта;
- Защита от снятия компонента с производства.



Как с нами связаться

Телефон: 8 (812) 309 58 32 (многоканальный)

Факс: 8 (812) 320-02-42

Электронная почта: org@eplast1.ru

Адрес: 198099, г. Санкт-Петербург, ул. Калинина, дом 2, корпус 4, литера А.