

SF2138B-1

**144.132 MHz
SAW Filter**

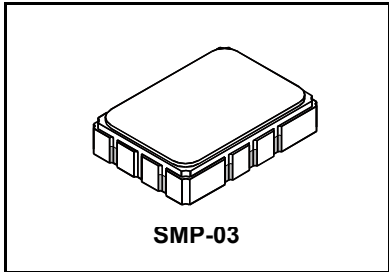

- **Designed for SDARS IF Receiver**
- **Low Insertion Loss**
- **5.0 x 7.0 mm Surface-mount Case**
- **Differential or Single-ended Input and Output**
- **Complies with Directive 2002/95/EC (RoHS)**



Absolute Maximum Ratings

Rating	Value	Units
Maximum Incident Power in Passband	+10	dBm
Maximum DC Voltage Between any Two Terminals	30	VDC
Storage Temperature Range	-40 to +85	°C
Operable Temperature Range	-45 to +125	°C
Max Soldering Profile	265 °C for 10 s	

Characteristic	Sym	Notes	Min	Typ	Max	Units
Nominal Center Frequency	f_C	1	144.132			MHz
Passband Width @ +25 °C			137.882		150.382	dB
B 1dB	BW ₁	1	12.5	13.3		MHz
B 15dB	BW ₁₅			15.9	16.2	MHz
B 30dB	BW ₃₀			16.9	18.2	MHz
Minimum Insertion Loss, including the Matching Network	IL _{MIN}			13.7	16.5	dB
Terminating source impedance			ZS = 200 ohms (differential)			
Terminating load impedance			ZL = 1.5K ohms (differential)			
Amplitude Ripple						
TDM1 (137.882 - 142.382 MHz)				1	1.7	dB _{P-P}
COFDM (141.882 - 146.182 MHz)				0.5	1.5	
TDM2 (145.882 - 150.382 MHz)				1	1.7	
Attenuation Relative to the Insertion Loss at Center Frequency:		1, 3				dBc
122.882 127.882 MHz			45	50		
127.882 132.882 MHz			43	47		
154.137 159.137 MHz			38	42		
159.137 162.882 MHz			43	47		
162.882 177.882 MHz			48	53		
Group Delay Ripple:						ns _{P-P}
TDM1 (137.882 - 142.382 MHz)				30	150	
COFDM (141.882 - 146.182 MHz)				28	100	
TDM2 (145.882 - 150.382 MHz)				30	150	
Specification Temperature Range	T _A	1	-40		+105	°C
Case Style			SMP-03 7 x 5 mm Nominal Footprint			
Lid Symbolization, YY=year, WW=week, S=shift		6	RFM SF2138B-1 YYWWSS			

Notes:

1. Unless noted otherwise, all specifications apply over the operating temperature range with filter soldered to the specified demonstration board with impedance matching to 50 Ω and measured with 50 Ω network analyzer.
2. Unless noted otherwise, all frequency specifications are referenced to the nominal center frequency, f_C .
3. Rejection is measured as attenuation below the minimum IL point in the passband. Rejection in final user application is dependent on PCB layout and external impedance matching design. See Application Note No. 42 for details.
4. "LRIP" or "L" after the part number indicates "low rate initial production" and "ENG" or "E" indicates "engineering prototypes."
5. The design, manufacturing process, and specifications of this filter are subject to change.
6. Tape and Reel Standard ANSI / EIA 481.
7. Either Port 1 or Port 2 may be used for either input or output in the design. However, impedances and impedance matching may vary between Port 1 and Port 2, so that the filter must always be installed in one direction per the circuit design.
8. US and international patents may apply.
9. Murata, stylized Murata logo, and Murata N.A., Inc. are registered trademarks of Murata Manufacturing Co., Ltd.
10. Electrostatic Sensitive Device. Observe precautions for handling.

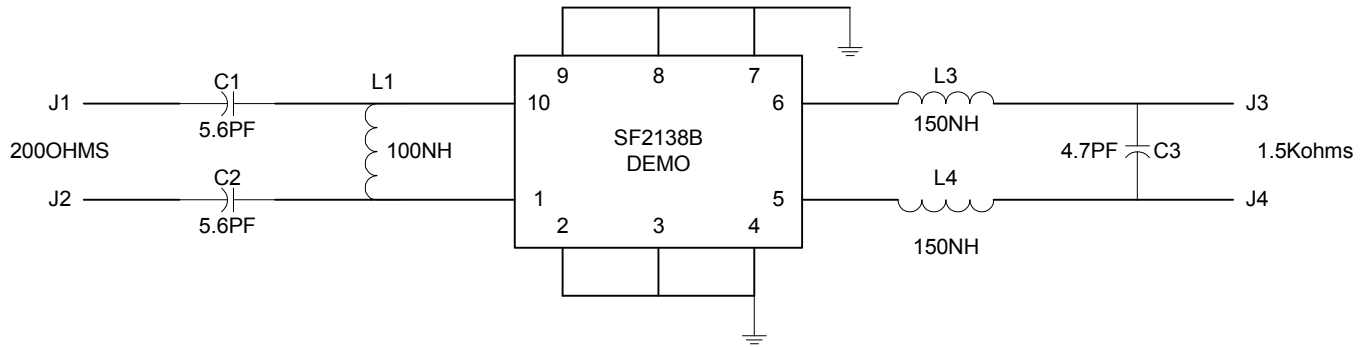

- | | | |
|--------------|------------------------|--------|
| 400-1749-001 | | |
| 501-0782-101 | 0805 COIL CRAFT, 100NH | L1 |
| 501-0782-151 | 0805 COIL CRAFT, 150NH | L2, L3 |
| 501-1275-056 | 0805, 5.6PF | C1, C2 |
| 501-1275-047 | 0805, 4.7PF | C3 |

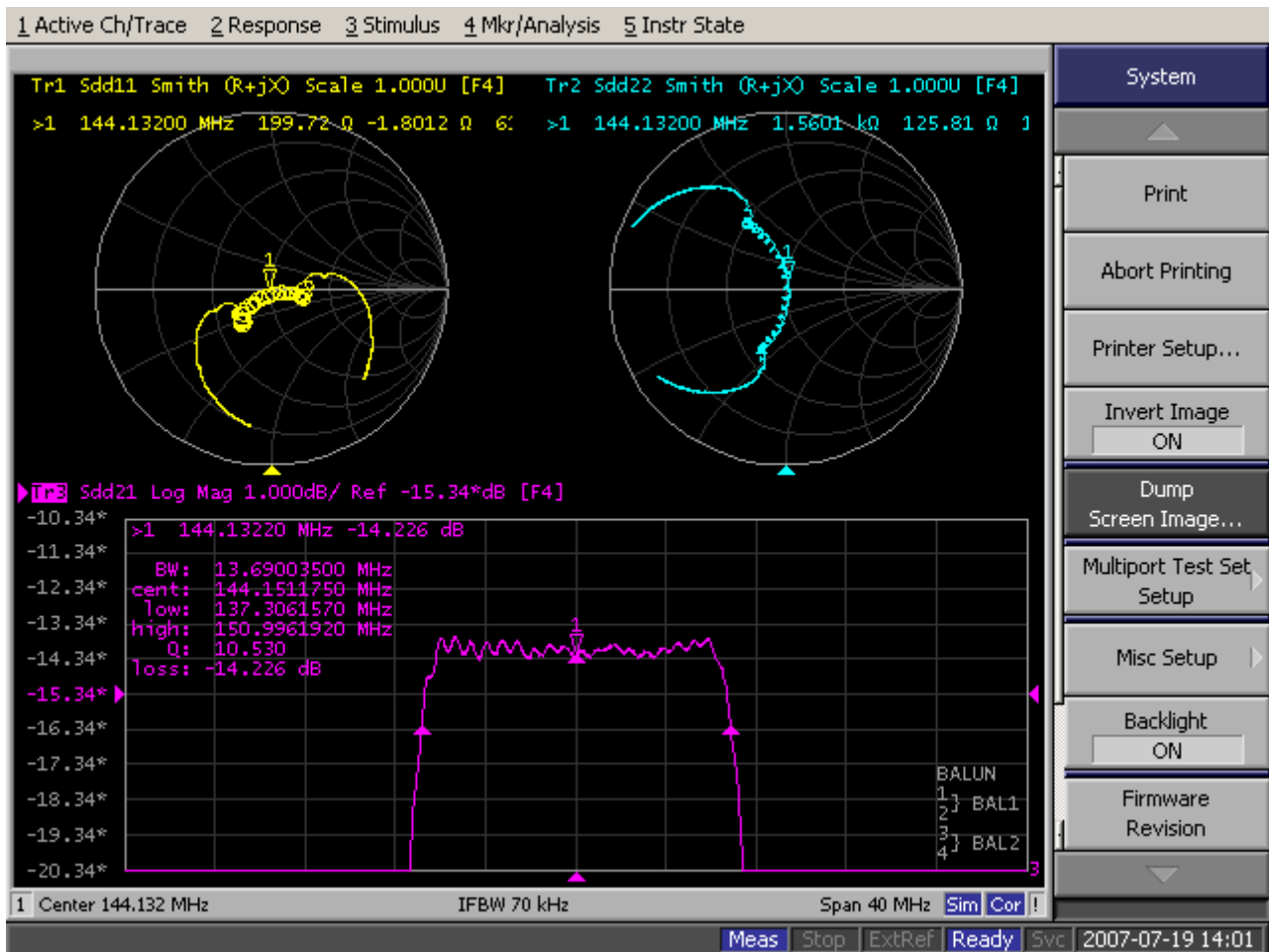

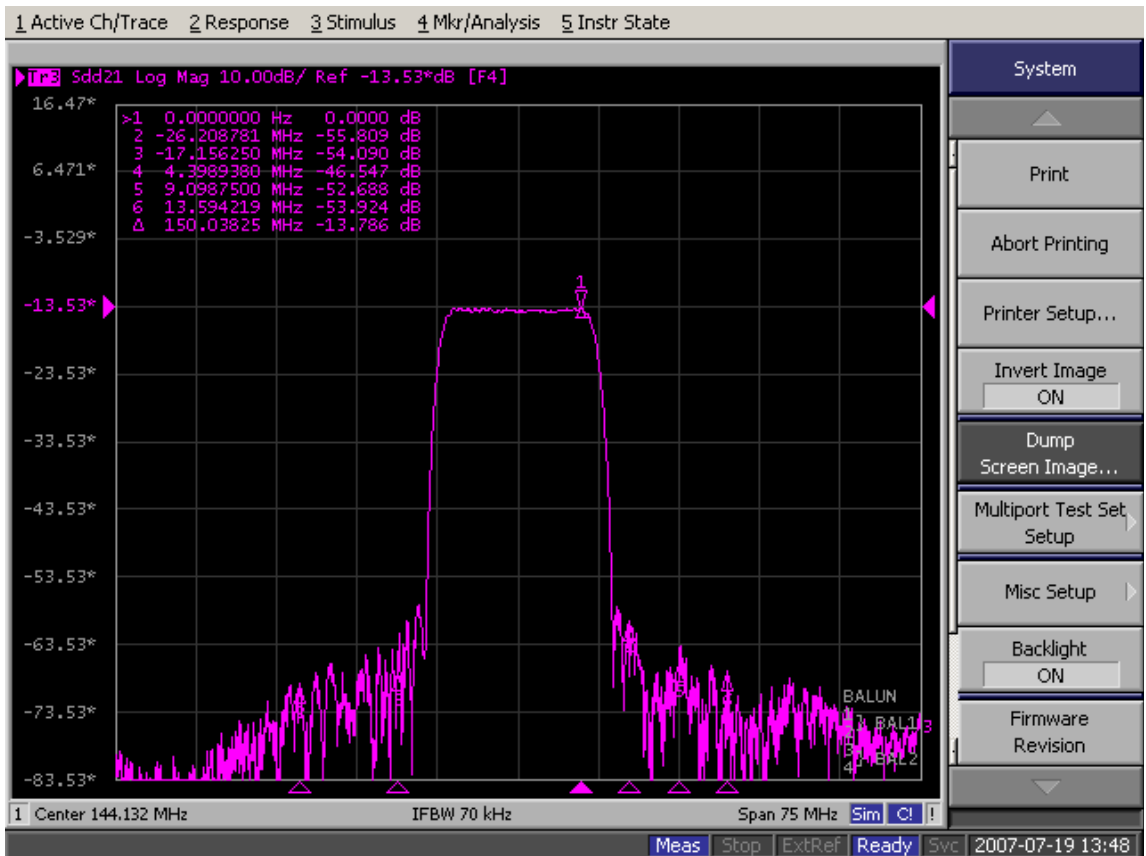
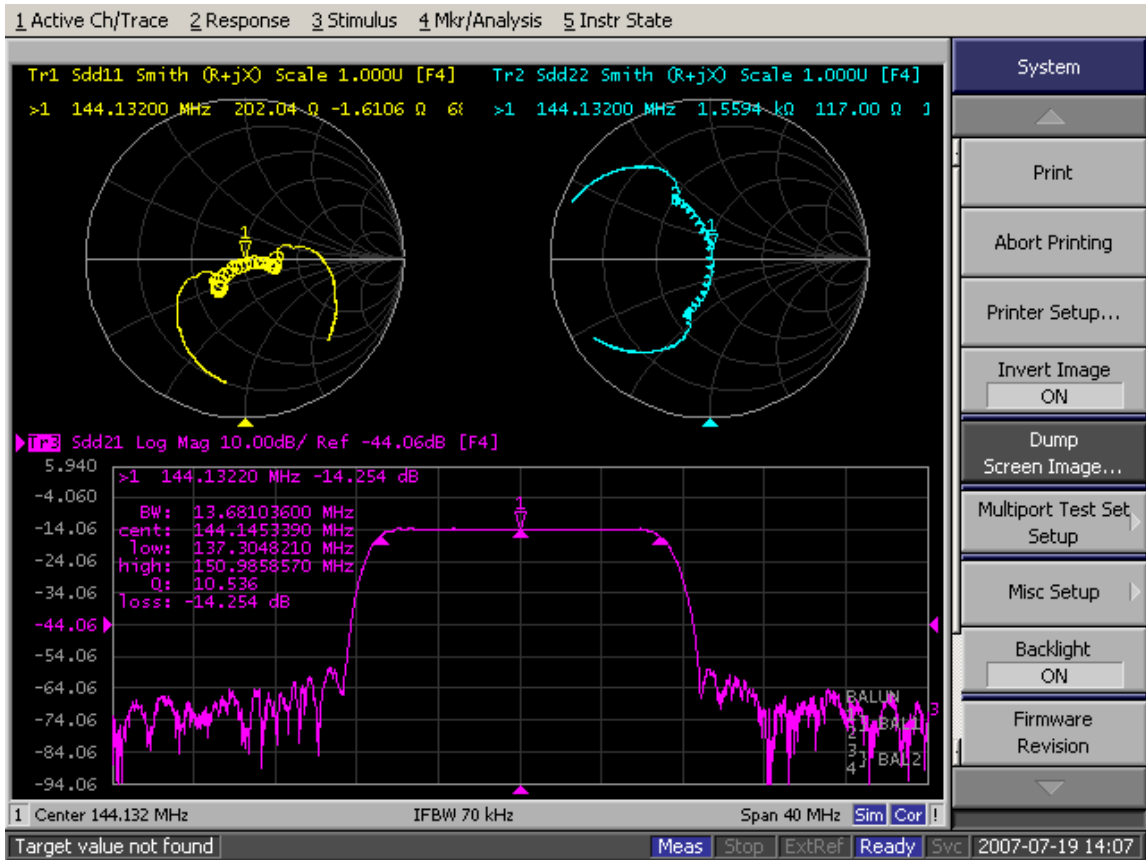

SMP-03 Case

10-Terminal Ceramic Surface-Mount Case

7 x 5 mm Nominal Footprint

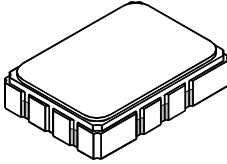

Recommended PCB Footprint

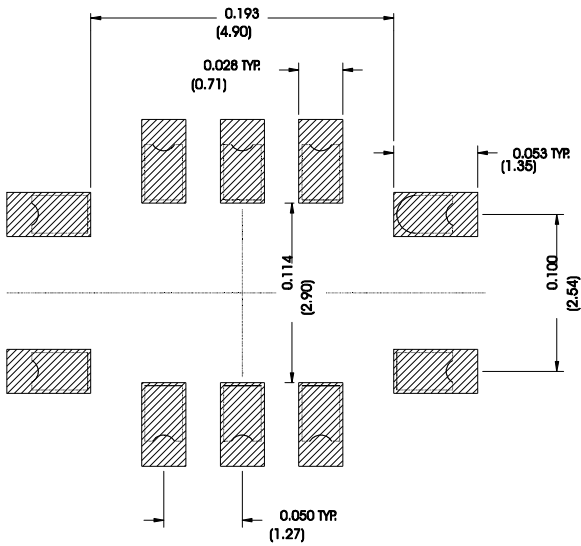

Case Dimensions						
Dimension	mm			Inches		
	Min	Nom	Max	Min	Nom	Max
A	6.80	7.00	7.20	0.268	0.276	0.283
B	4.80	5.00	5.20	0.189	0.197	0.205
C		1.65	2.00		0.065	0.079
D	.47	0.60	.73	0.019	0.024	0.029
E	2.41	2.54	2.67	0.095	0.100	0.105
H	0.87	1.0	1.13	0.034	0.039	0.044
J	4.87	5.00	5.13	0.192	0.197	0.202
K	2.87	3.00	3.13	0.113	0.118	0.123
P	1.14	1.27	1.40	0.045	0.050	0.055

Electrical Connections		
Connection		Terminals
Port 1	Input or Return	10
	Return or Input	1
Port 2	Output or Return	5
	Return or Output	6
Ground		All others
Single-ended Operation		Return is ground
Differential Operation		Return is hot

Materials	
Solder Pad Plating	0.3 to 1.0 μ m Gold over 1.27 to 8.89 μ m Nickel
Lid Plating	2.0 to 3.0 μ m Nickel
Body	Al ₂ O ₃ Ceramic
Pb Free	

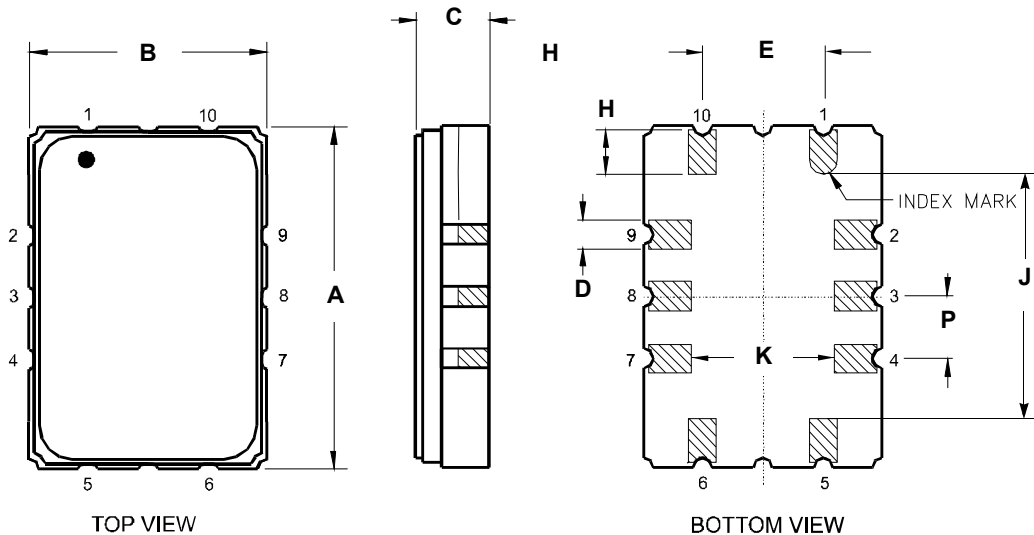

Tape and Reel Specifications

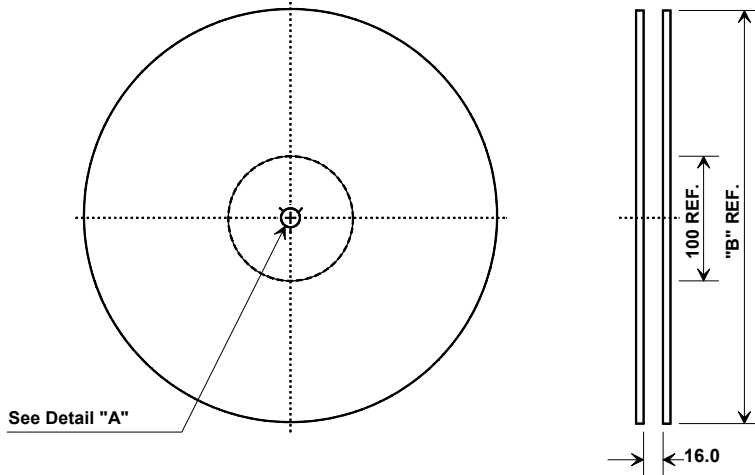

"B" Nominal Size		Quantity Per Reel
Inches	millimeters	
7	178	500
13	330	2000

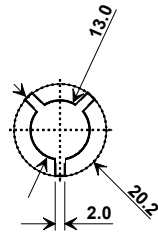

COMPONENT ORIENTATION and DIMENSIONS

Carrier Tape Dimensions	
Ao	5.5 mm
Bo	7.5 mm
Ko	2.0 mm
Pitch	8.0 mm
W	16.0 mm

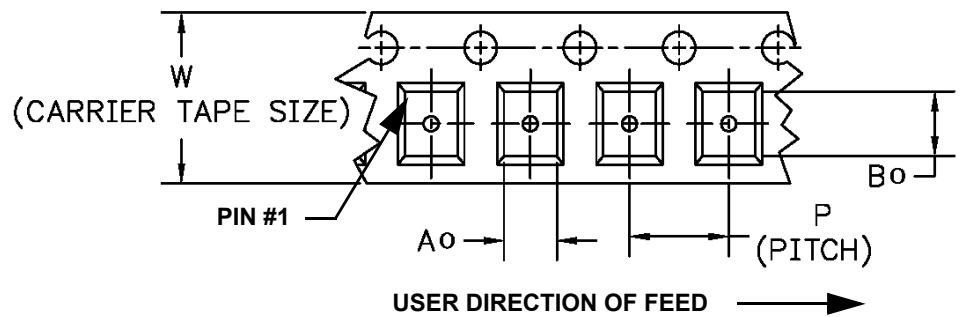
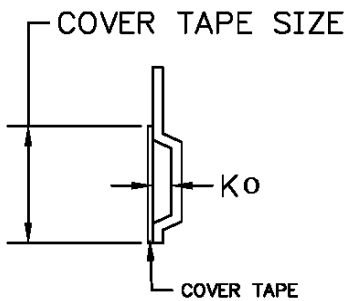



Компания «ЭлектроПласт» предлагает заключение долгосрочных отношений при поставках импортных электронных компонентов на взаимовыгодных условиях!

Наши преимущества:

- Оперативные поставки широкого спектра электронных компонентов отечественного и импортного производства напрямую от производителей и с крупнейших мировых складов;
- Поставка более 17-ти миллионов наименований электронных компонентов;
- Поставка сложных, дефицитных, либо снятых с производства позиций;
- Оперативные сроки поставки под заказ (от 5 рабочих дней);
- Экспресс доставка в любую точку России;
- Техническая поддержка проекта, помощь в подборе аналогов, поставка прототипов;
- Система менеджмента качества сертифицирована по Международному стандарту ISO 9001;
- Лицензия ФСБ на осуществление работ с использованием сведений, составляющих государственную тайну;
- Поставка специализированных компонентов (Xilinx, Altera, Analog Devices, Intersil, Interpoint, Microsemi, Aeroflex, Peregrine, Syfer, Eurofarad, Texas Instrument, Miteq, Cobham, E2V, MA-COM, Hittite, Mini-Circuits, General Dynamics и др.);

Помимо этого, одним из направлений компании «ЭлектроПласт» является направление «Источники питания». Мы предлагаем Вам помощь Конструкторского отдела:

- Подбор оптимального решения, техническое обоснование при выборе компонента;
- Подбор аналогов;
- Консультации по применению компонента;
- Поставка образцов и прототипов;
- Техническая поддержка проекта;
- Защита от снятия компонента с производства.



Как с нами связаться

Телефон: 8 (812) 309 58 32 (многоканальный)

Факс: 8 (812) 320-02-42

Электронная почта: org@eplast1.ru

Адрес: 198099, г. Санкт-Петербург, ул. Калинина, дом 2, корпус 4, литера А.