

PULL OUT DIRECTION

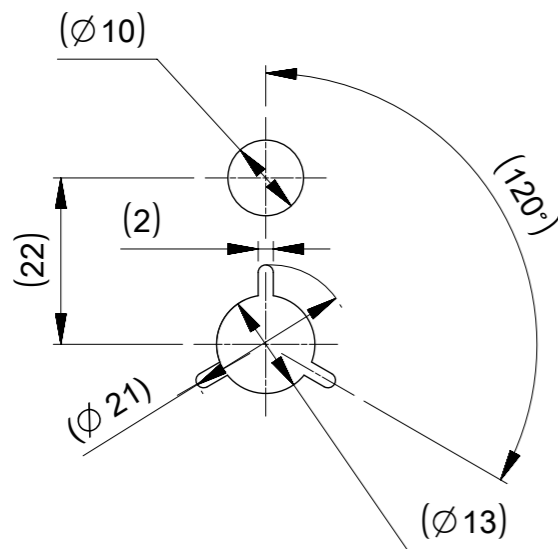
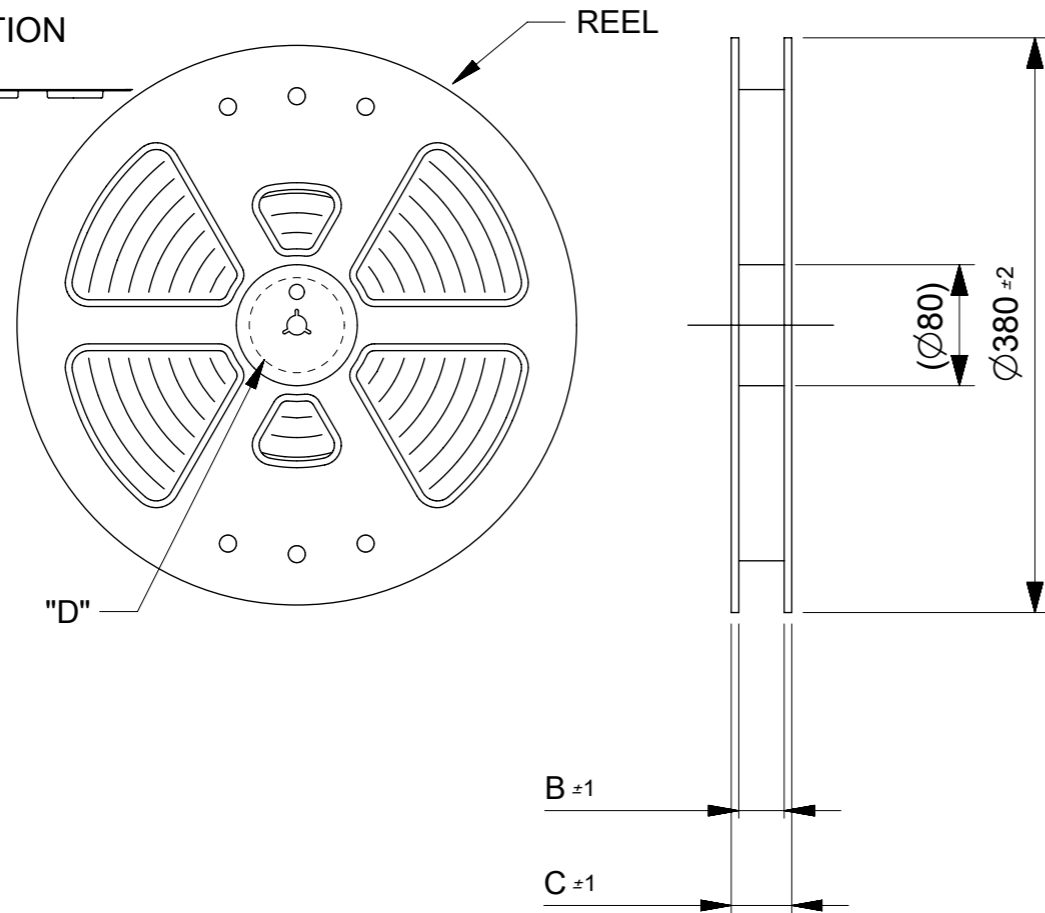

DETAIL "D"

NOTES

1. RE DETAILED DIMENSION, SEE PRODUCT DRAWING.
2. NUMBER OF CONNECTORS : 8000 PCS/REEL.
3. LEAD TAPE LENGTH.

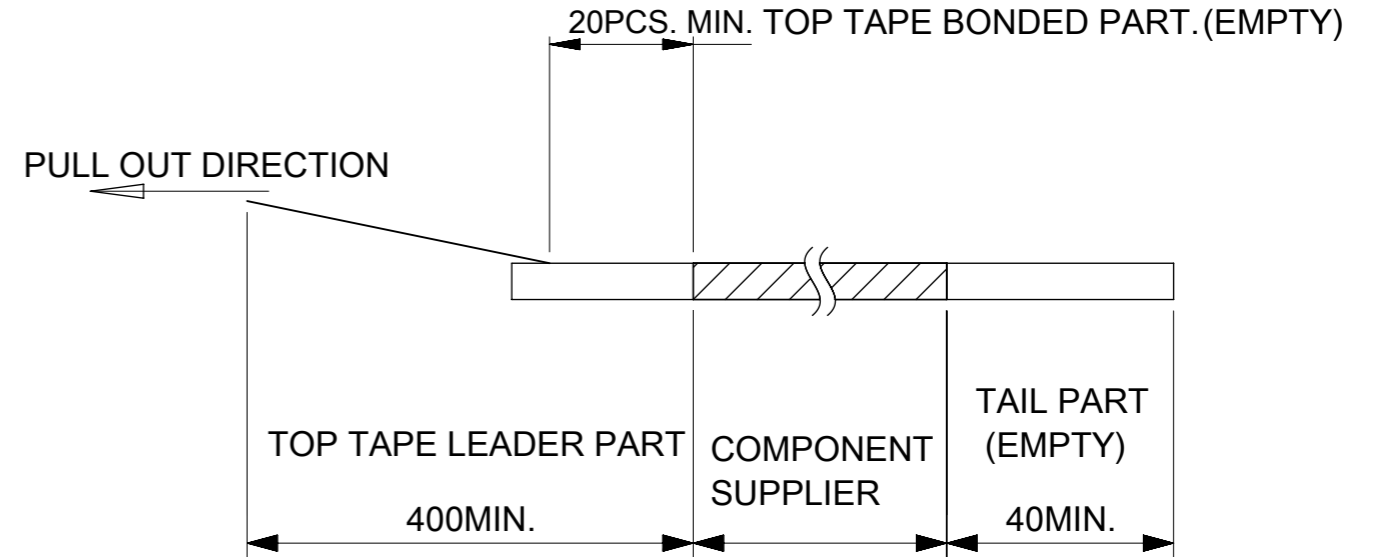

4. TOP TAPE PEEL FORCE IS DEFINED BY IEC60286-3
5. MATERIAL
CARRER TAPE :POLYSTYRENE
TOP TAPE :PET , OTHER
REEL :POLYSTYRENE(PS)(RECYCLE MATERIAL CONTAINED)
- △ ONLY 6 CIRCUIT IS DIFFERENT IN THIS DIMENSION.

MODEL NO. 505070-**42

THIS DRAWING CONTAINS INFORMATION THAT IS PROPRIETARY TO MOLEX ELECTRONIC TECHNOLOGIES, LLC AND SHOULD NOT BE USED WITHOUT WRITTEN PERMISSION		CURRENT REV DESC: REVISED		molex	
DIMENSION UNITS	SCALE				
mm	1:5			PRODUCT CUSTOMER DRAWING	
GENERAL TOLERANCES (UNLESS SPECIFIED)		EC NO: 612826		DOCUMENT NUMBER	
ANGULAR TOL	± 1.0 °	DRWN: GSHARMA 2019/02/22		5050700000	
4 PLACES	± 0.01	CHK'D: MSASAO 2019/02/27		DOC TYPE	DOC PART
3 PLACES	± 0.03	APPR: MSASAO 2019/02/27		PSD	008
2 PLACES	± 0.05	INITIAL REVISION:		REVISION	C
1 PLACE	± 0.1	DRWN: TNISHIDA02 2017/03/28			
0 PLACES	± 0.2	APPR: TKUSUHARA01 2017/04/03			
DRAFT WHERE APPLICABLE MUST REMAIN WITHIN DIMENSIONS		THIRD ANGLE PROJECTION	DRAWING	SERIES	MATERIAL NUMBER
			A3-SIZE	505070	CUSTOMER
				GENERAL	SHEET NUMBER
				1 OF 3	

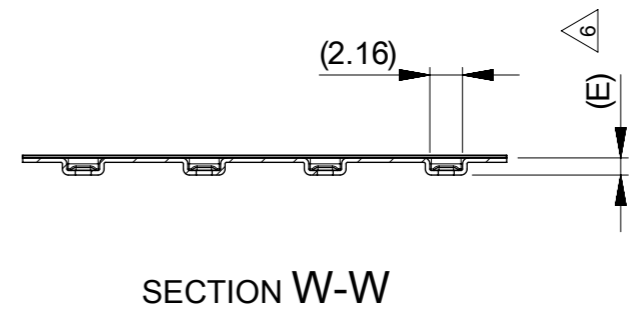
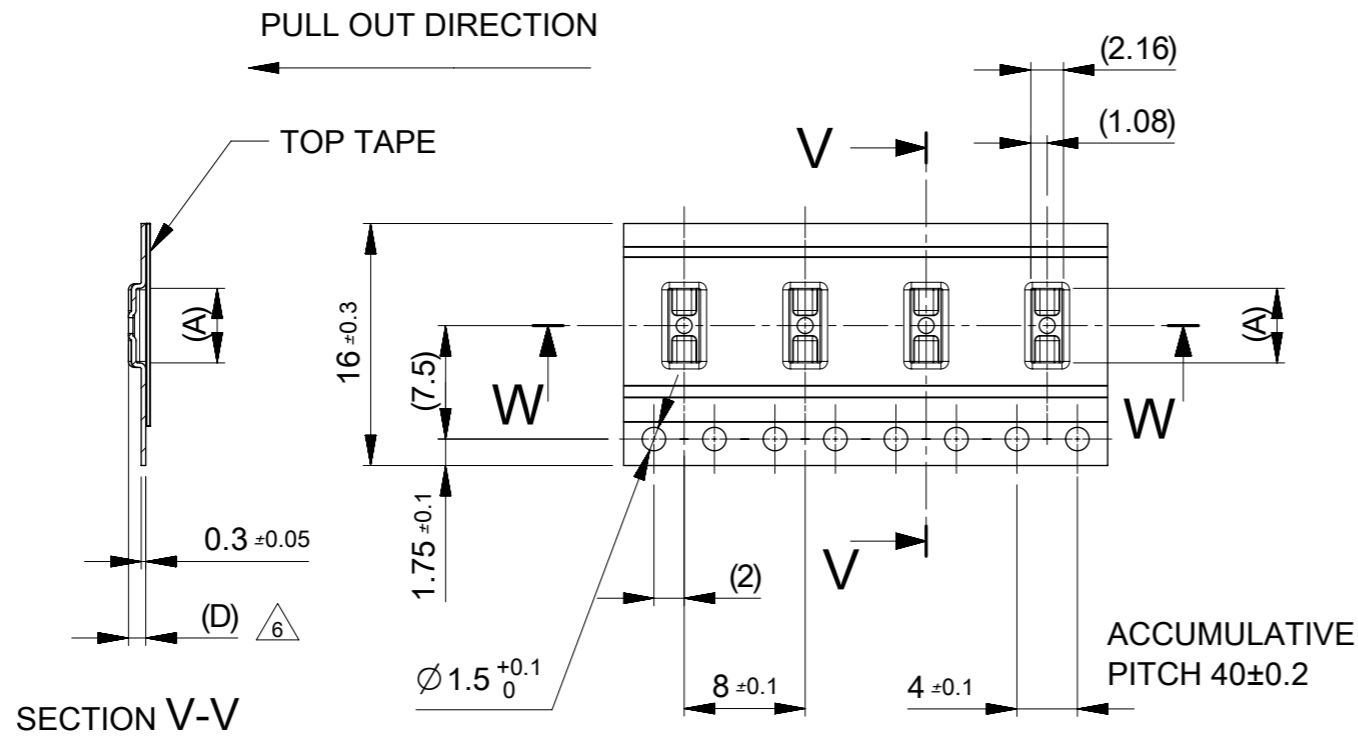

16	0.64	1.14	21.4	17.4	6.68	505070-3042	○	---	30				
					5.63	505070-2442	○	---	24				
					5.28	505070-2242	○	---	22				
					4.93	505070-2042	○	---	20				
					4.58	505070-1842	---	---	18				
					4.23	505070-1642	○	---	16				
					3.88	505070-1442	○	---	14				
					3.53	505070-1242	○	---	12				
					3.18	505070-1042	○	---	10				
					2.78	505070-0842	○	---	8				
					2.43	505070-0642	○	---	6				
キャリアテープ幅 CARRIER TAPE WIDTH					(E)	(D)	C	B	(A)	MATERIAL No.	HIGH VOL. TOOL	LOW VOL. TOOL	CIRCUIT
SAMPLE PREPARATION													

THIS DRAWING CONTAINS INFORMATION THAT IS PROPRIETARY TO MOLEX ELECTRONIC TECHNOLOGIES, LLC AND SHOULD NOT BE USED WITHOUT WRITTEN PERMISSION

DIMENSION UNITS mm	SCALE 2:1	CURRENT REV DESC: REVISED					
GENERAL TOLERANCES (UNLESS SPECIFIED)		<p style="text-align: center;">molex</p> <p style="text-align: center;">0.35 BB CONN. H=0.6 SSB6 RP PLUG ASSY</p> <p style="text-align: center;">PRODUCT CUSTOMER DRAWING</p>					
ANGULAR TOL	± 1.0 °						
4 PLACES	± 0.01						
3 PLACES	± 0.03						
2 PLACES	± 0.05						
1 PLACE	± 0.1						
0 PLACES	± 0.2	EC NO: 612826 DRWN: GSHARMA 2019/02/22 CHK'D: MSASAO 2019/02/27 APPR: MSASAO 2019/02/27 INITIAL REVISION: DRWN: TNISHIDA02 2017/03/28 APPR: TKUSUHARA01 2017/04/03					
DRAFT WHERE APPLICABLE MUST REMAIN WITHIN DIMENSIONS		THIRD ANGLE PROJECTION	DRAWING	SERIES	MATERIAL NUMBER	CUSTOMER	SHEET NUMBER
			A3-SIZE	505070	5050700000	GENERAL	2 OF 3

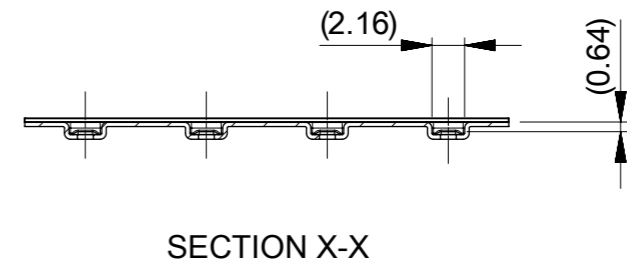
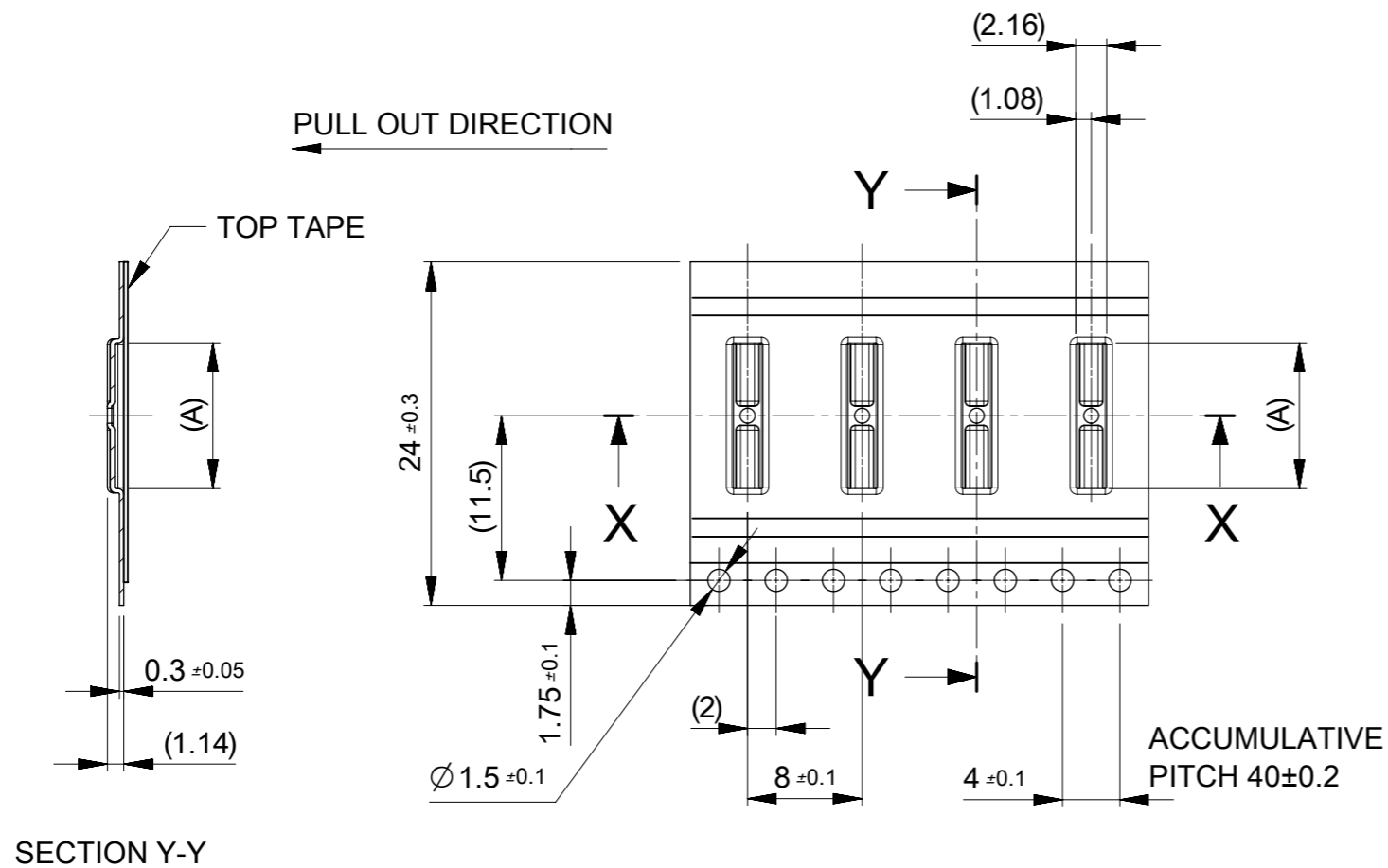

24	29.4	25.4	12.63	505070-6442	---	---	64
			11.93	505070-6042	---	---	60
			10.88	505070-5442	○	---	54
			10.18	505070-5042	○	---	50
			9.83	505070-4842	○	---	48
			9.48	505070-4642	---	---	46
			8.78	505070-4242	○	---	42
			8.43	505070-4042	○	---	40
			7.38	505070-3442	○	---	34
7.03	505070-3242	---	---	32			
キャリアテープ幅 CARRIER TAPE WIDTH	C	B	(A)	MATERIAL No.	HIGH VOL TOOL	LOW VOL TOOL	CIRCUIT
					SAMPLE PREPARATION		

THIS DRAWING CONTAINS INFORMATION THAT IS PROPRIETARY TO MOLEX ELECTRONIC TECHNOLOGIES, LLC AND SHOULD NOT BE USED WITHOUT WRITTEN PERMISSION

DIMENSION UNITS mm	SCALE 2:1	CURRENT REV DESC: REVISED		molex			
GENERAL TOLERANCES (UNLESS SPECIFIED)		EC NO: 612826					0.35 BB CONN. H=0.6 SSB6 RP PLUG ASSY
ANGULAR TOL	± 1.0°	DRWN: GSHARMA 2019/02/22		PRODUCT CUSTOMER DRAWING			
4 PLACES	± 0.01	CHK'D: MSASAO 2019/02/27		DOCUMENT NUMBER			
3 PLACES	± 0.03	APPR: MSASAO 2019/02/27		5050700000			
2 PLACES	± 0.05	INITIAL REVISION:		DOC TYPE	DOC PART	REVISION	
1 PLACE	± 0.1	DRWN: TNISHIDA02 2017/03/28		PSD	008	C	
0 PLACES	± 0.2	APPR: TKUSUHARA01 2017/04/03		SHEET NUMBER			
DRAFT WHERE APPLICABLE MUST REMAIN WITHIN DIMENSIONS		THIRD ANGLE PROJECTION	DRAWING	SERIES	MATERIAL NUMBER	CUSTOMER	SHEET NUMBER
			A3-SIZE	505070		GENERAL	3 OF 3

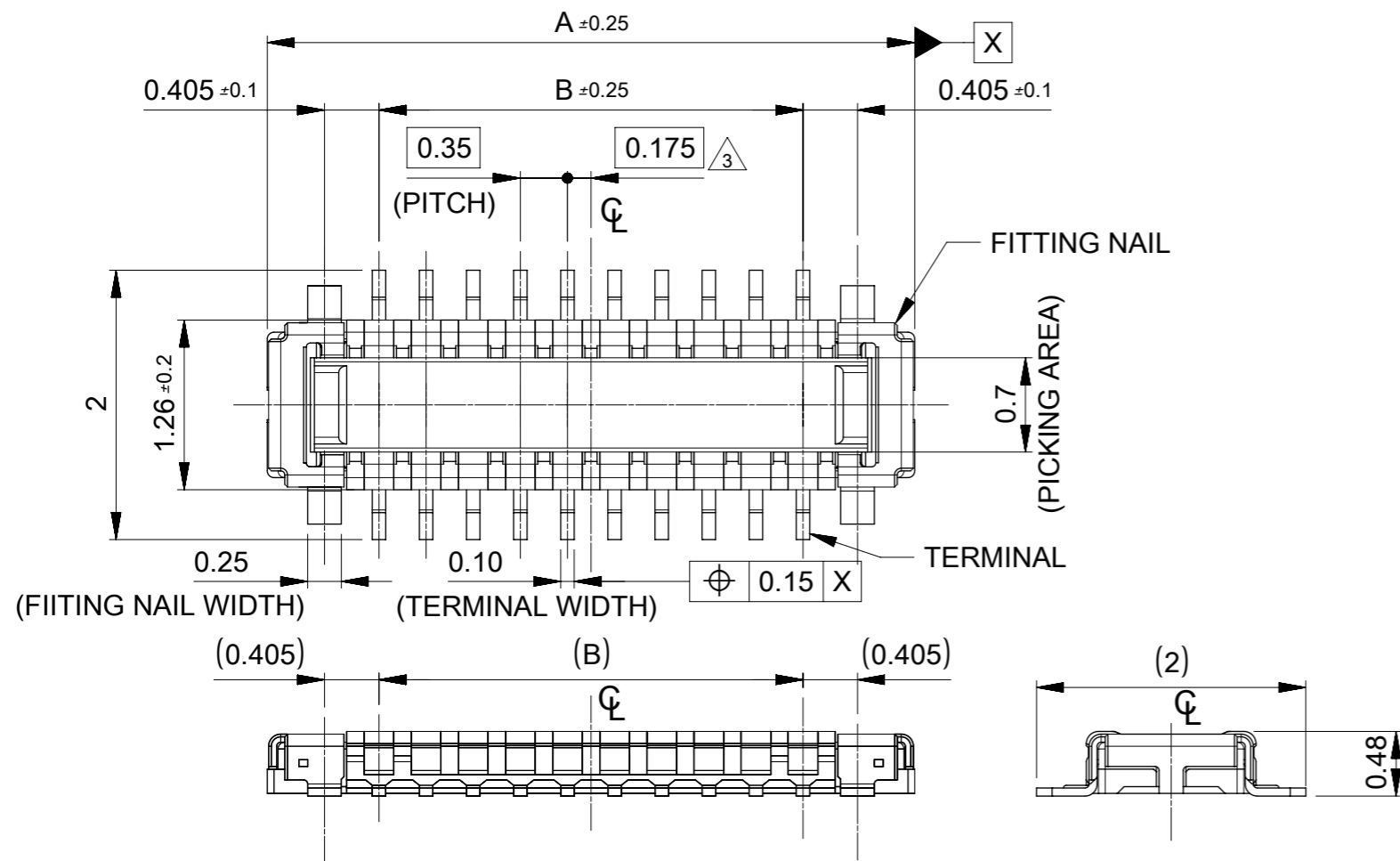

- 1 MATERIAL
 WAFER: LIQUID CRYSTAL POLYMER UL94V-0 (COLOR: BLACK)
 TERMINAL: COPPER ALLOY
 FITTING NAIL: COPPER ALLOY
- 2 PLATING
 TERMINAL:
 CONTACT AREA: SEPARATED GOLD PLATING (0.1 MICROMETER MINIMUM).
 SOLDER TAIL AREA: SEPARATED GOLD PLATING.
 UNDERPLATE: NICKEL OVERALL.
 *DIVIDE INTO PARTS THE GOLD PLATING OF THE CONTACT AND THE TAIL PART BY THE NICKEL PLATING.
 FITTING NAIL:
 CONTACT AREA: SEPARATED GOLD PLATING (0.1 MICROMETER MINIMUM).
 SOLDER TAIL AREA: SEPARATED GOLD PLATING.
 UNDERPLATE: NICKEL OVERALL.
 *DIVIDE INTO PARTS THE GOLD PLATING OF THE CONTACT AND THE TAIL PART BY THE NICKEL PLATING.
 *EVEN THOUGH GOLD PLATING ON THE TOP SURFACE OF NAIL MIGHT BE THIN, NO FUNCTIONAL PROBLEM.
- 3 APPLY FOR (CIRCUIT/2)=EVEN.
- 4 MATE WITH: 505066-**22
- 5 TAIL AND FITTING NAIL COPLANARITY TO BE 0.08 MAXIMUM.
- 6 PROHIBITED AREA OF PATTERN WIRING AND SOLDER. (FOR EACH AREA, THE WIRING THAT TOUCHES ON THE SOLDER CAN BE ATTACHED, THEN COVERED WITH A FILM TO KEEP SOLDER OUT).

14.76	14.16	11.90	13.56	505070-7042	---	---	70
13.71	13.11	10.85	12.51	505070-6442	---	---	64
13.01	12.41	10.15	11.81	505070-6042	---	---	60
12.66	12.06	9.80	11.46	505070-5842	---	---	58
11.96	11.36	9.10	10.76	505070-5442	○	---	54
11.26	10.66	8.40	10.06	505070-5042	○	---	50
10.91	10.31	8.05	9.71	505070-4842	○	---	48
10.56	9.96	7.70	9.36	505070-4642	---	---	46
9.86	9.26	7.00	8.66	505070-4242	○	---	42
9.51	8.91	6.65	8.31	505070-4042	○	---	40
9.16	8.56	6.30	7.96	505070-3842	---	---	38
8.46	7.86	5.60	7.26	505070-3442	○	---	34
8.11	7.51	5.25	6.91	505070-3242	---	---	32
7.76	7.16	4.90	6.56	505070-3042	○	---	30
7.41	6.81	4.55	6.21	505070-2842	---	---	28
6.71	6.11	3.85	5.51	505070-2442	○	---	24
6.36	5.76	3.50	5.16	505070-2242	○	---	22
6.01	5.41	3.15	4.81	505070-2042	○	---	20
5.66	5.06	2.80	4.46	505070-1842	---	---	18
5.31	4.71	2.45	4.11	505070-1642	○	---	16
4.96	4.36	2.10	3.76	505070-1442	○	---	14
4.61	4.01	1.75	3.41	505070-1242	○	---	12
4.26	3.66	1.40	3.06	505070-1042	○	---	10
3.91	3.31	1.05	2.71	505070-0842	○	---	8
3.56	2.96	0.70	2.36	505070-0642	○	---	6

D	C	B	A	EMBOSSED TAPE PACKAGE	HIGH VOL. TOOL	LOW VOL. TOOL	CIRCUIT
				ORDER NO.	SAMPLE PREPARATION ○ : TOOLED △ : WORK IN PROCESS ---: TOOLING TO BE CONFIRMED		

CONNECTOR SERIES NO. : 505070-**39

THIS DRAWING CONTAINS INFORMATION THAT IS PROPRIETARY TO MOLEX ELECTRONIC TECHNOLOGIES, LLC AND SHOULD NOT BE USED WITHOUT WRITTEN PERMISSION

CURRENT REV DESC: REVISED

molex

0.35 BB CONN. SSB6 RP PLUG ASSY

PRODUCT CUSTOMER DRAWING

DOCUMENT NUMBER: 5050701000 | DOC TYPE: PSD | DOC PART: 020 | REVISION: C

INITIAL REVISION:
 DRWN: TNISHIDA02 2017/03/28
 APPR: TKUSUHARA01 2017/04/03

DRAFT WHERE APPLICABLE MUST REMAIN WITHIN DIMENSIONS

THIRD ANGLE PROJECTION

DRAWING: A3-SIZE | SERIES: 505070

MATERIAL NUMBER: | CUSTOMER: GENERAL | SHEET NUMBER: 1 OF 2

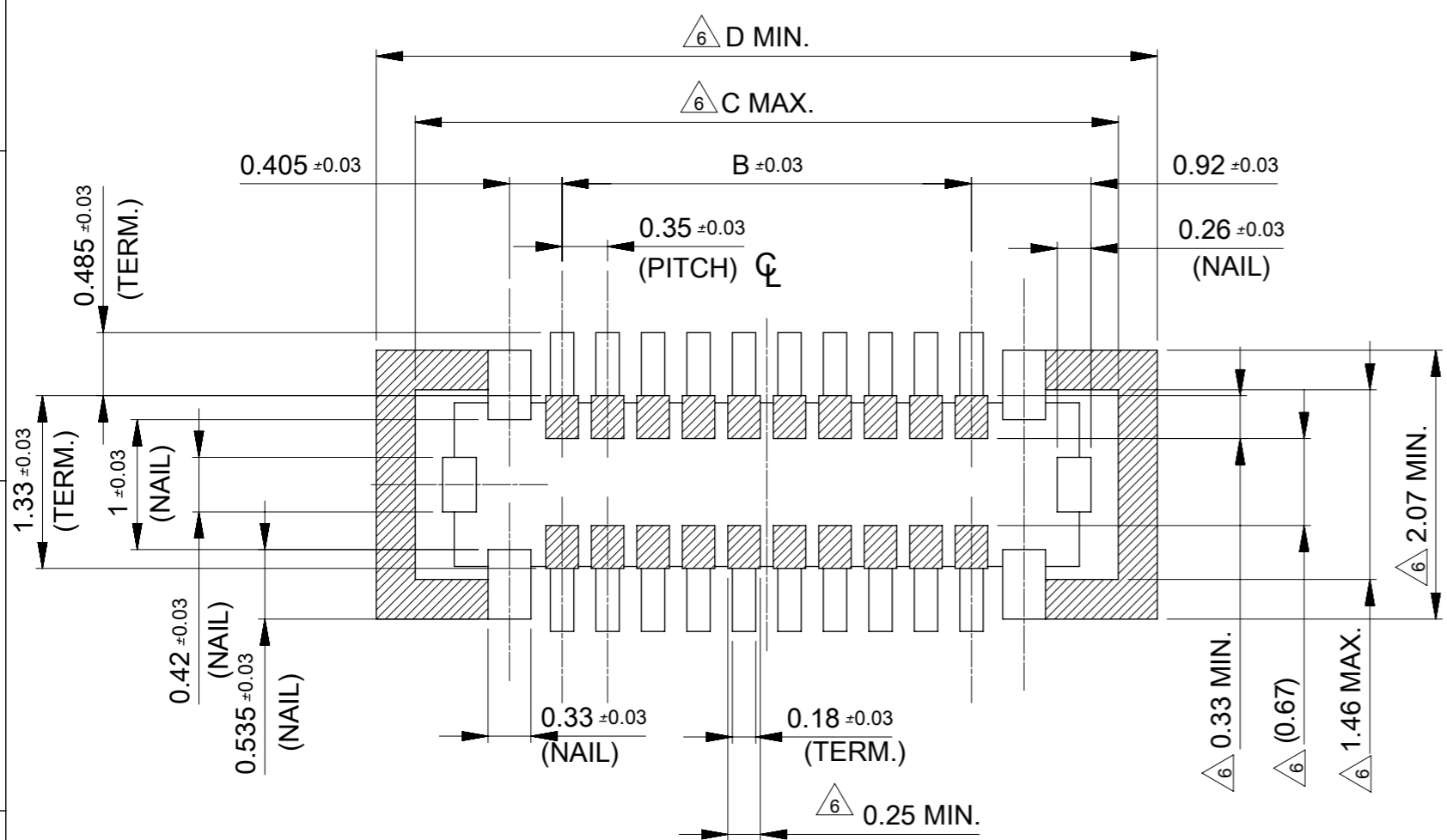

RECOMENDED P.W.BOARD PATTERN LAYOUT(REFFRECE)

$\triangle 6$ PROHIBITED AREA OF PATTERN WIRING AND SOLDER.
(FOR EACH AREA, THE WIRING THAT TOUCHES ON THE SOLDER CAN BE ATTACHED, THEN COVERED WITH A FILM TO KEEP SOLDER OUT.)

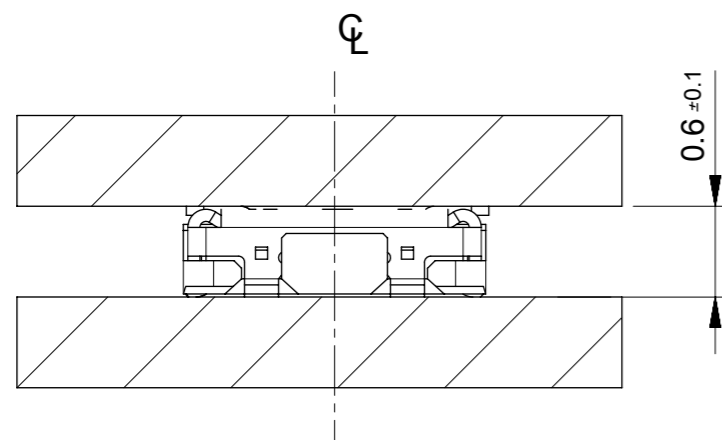

MATED CONDITION

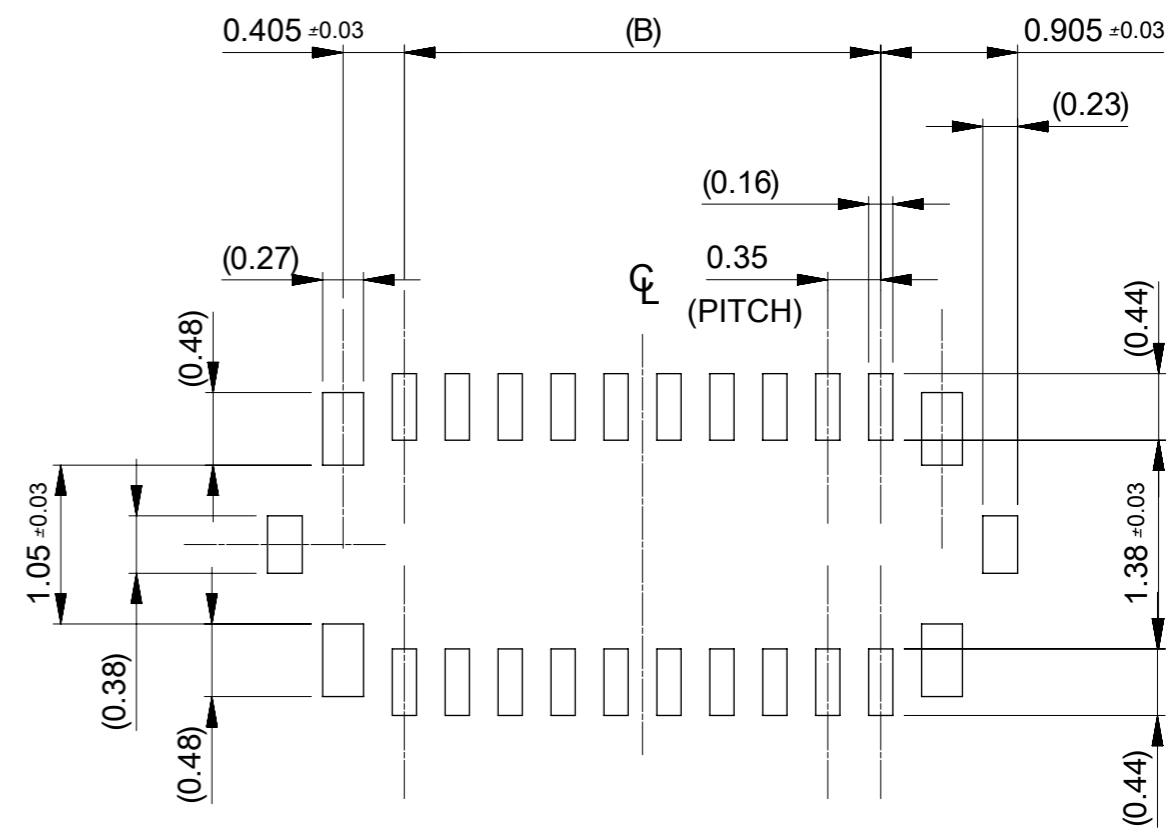

RECOMENDED METAL MASK LAYOUT(REFFRECE)

RECOMMENDED THICKNESS OF METAL MASK : $t=0.08\text{MM}$
RECOMMENDED OPEN APERTURE RATIO OF METAL MASK : 80%

THIS DRAWING CONTAINS INFORMATION THAT IS PROPRIETARY TO MOLEX ELECTRONIC TECHNOLOGIES, LLC AND SHOULD NOT BE USED WITHOUT WRITTEN PERMISSION		CURRENT REV DESC: REVISED		molex	
DIMENSION UNITS	SCALE				
mm	20:1			0.35 BB CONN. SSB6 RP PLUG ASSY	
GENERAL TOLERANCES (UNLESS SPECIFIED)				PRODUCT CUSTOMER DRAWING	
ANGULAR TOL	± 1.0 °	EC NO:	612826	DOCUMENT NUMBER	
4 PLACES	± 0.01	DRWN:	GSHARMA 2019/02/22	5050701000	
3 PLACES	± 0.03	CHK'D:	MSASAO 2019/02/27	DOC TYPE	DOC PART
2 PLACES	± 0.05	APPR:	MSASAO 2019/02/27	PSD	020
1 PLACE	± 0.1	INITIAL REVISION:		REVISION	C
0 PLACES	± 0.2	DRWN:	TNISHIDA02 2017/03/28		
DRAFT WHERE APPLICABLE MUST REMAIN WITHIN DIMENSIONS		APPR:	TKUSUHARA01 2017/04/03		
THIRD ANGLE PROJECTION		DRAWING	SERIES	MATERIAL NUMBER	CUSTOMER
		A3-SIZE	505070	GENERAL	SHEET NUMBER
				2 OF 2	



Компания «ЭлектроПласт» предлагает заключение долгосрочных отношений при поставках импортных электронных компонентов на взаимовыгодных условиях!

Наши преимущества:

- Оперативные поставки широкого спектра электронных компонентов отечественного и импортного производства напрямую от производителей и с крупнейших мировых складов;
- Поставка более 17-ти миллионов наименований электронных компонентов;
- Поставка сложных, дефицитных, либо снятых с производства позиций;
- Оперативные сроки поставки под заказ (от 5 рабочих дней);
- Экспресс доставка в любую точку России;
- Техническая поддержка проекта, помощь в подборе аналогов, поставка прототипов;
- Система менеджмента качества сертифицирована по Международному стандарту ISO 9001;
- Лицензия ФСБ на осуществление работ с использованием сведений, составляющих государственную тайну;
- Поставка специализированных компонентов (Xilinx, Altera, Analog Devices, Intersil, Interpoint, Microsemi, Aeroflex, Peregrine, Syfer, Eurofarad, Texas Instrument, Miteq, Cobham, E2V, MA-COM, Hittite, Mini-Circuits, General Dynamics и др.);

Помимо этого, одним из направлений компании «ЭлектроПласт» является направление «Источники питания». Мы предлагаем Вам помощь Конструкторского отдела:

- Подбор оптимального решения, техническое обоснование при выборе компонента;
- Подбор аналогов;
- Консультации по применению компонента;
- Поставка образцов и прототипов;
- Техническая поддержка проекта;
- Защита от снятия компонента с производства.



Как с нами связаться

Телефон: 8 (812) 309 58 32 (многоканальный)

Факс: 8 (812) 320-02-42

Электронная почта: org@eplast1.ru

Адрес: 198099, г. Санкт-Петербург, ул. Калинина, дом 2, корпус 4, литера А.