

REFERENCE SPECIFICATIONS

-NFC 93425 (in compliance with HE 507)

PHYSICAL CHARACTERISTICS

- INSULATOR MATERIAL: THERMOPLASTIC .UL94V0
- ACCESSORIES: BRASS
- SHELLS: STEEL

ELECTRICAL CHARACTERISTICS

- CONTACT/CONTACT : >=1000 V
- CONTACT/GROUND : >=1200 V
- INSULATION RESISTANCE: >=5000 MOhms

ENVIRONMENTAL CHARACTERISTICS

- CLIMATIC CATEGORY: 55/125/21
- TEMPERATURE RANGE -55°C TO +125°C
- DAMP HEAT STEADY STATE 21 DAYS
- SALT SPRAY 24 HOURS

MECHANICAL CHARACTERISTICS

- RETENTION AGAINST TORQUE:
 - Threaded insert: 0.7 N.m minimum
 - Female screw : 0.5 N.m minimum

NOTE RoHS INFORMATION

- The "LF" products meet european union Directives and other country regulations as described in GS-22-008.
- Shell plating :2 to 4 μm Cu+ Ni + 3 to 10 μm Sn(pure bright)
- Accessories: Sn pure bright + nickel
- Packaging spec: See GS-14-920

Series **DBL5W5SA00LF**

Shell size: E A B C
see sheet 2

Front accessory definition
see sheet 2

- Blank :without accessory
- L : Threaded insert M3
- 0 : Threaded insert UNC 4-40
- V : Female screw UNC 4-40

Layout of contacts (see sheet 3)

Contacts
S :Socket

PCB accessory definition
A witout accessory on PCB

Power contacts
00 without power contact

See note RoHS

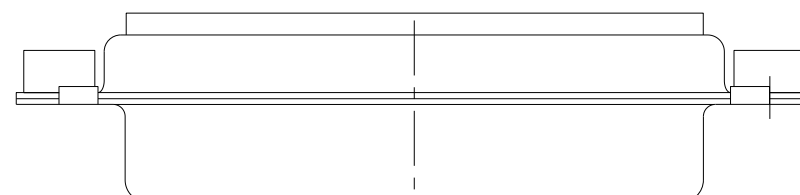

spec ref	dr	Pro Engineer 1	2015/06/16	projection	mm	size	A2	scale	2:1
tolerance std	eng	J Dalbard	2016/09/13			ecn no	ECN-ELXF-24942-1	rel level	Released
TOLERANCES UNLESS OTHERWISE SPECIFIED	chr	J Dalbard	2016/09/19						
	appr	Aymeric Soudy	2016/09/20						
surface	linear	0.X	±0.3	Amphenol FCI		product family	SUB FEMALE DW	diag no	C01-8639-2311
		0.XX	±0.10				full power without contact	rev	E
	angular	0°	±2°			cat. no.	Product - Customer Drw	sheet 1 of 4	

FIRST ANGLE PROJECTION

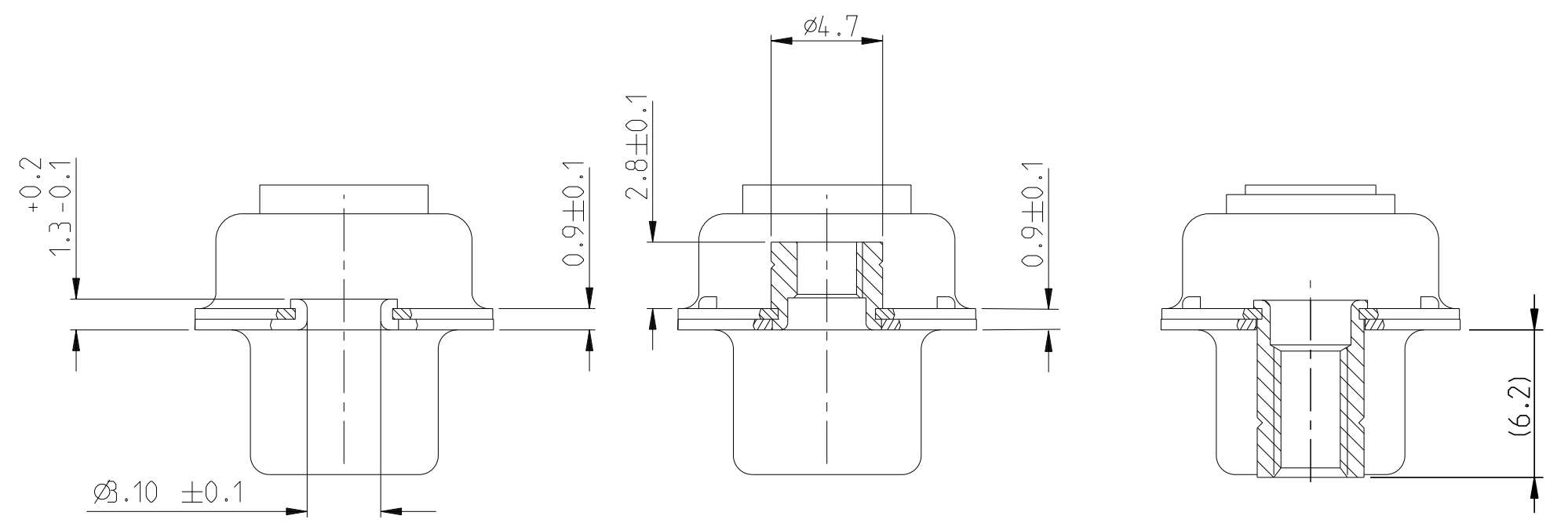

FRONT ACCESSORY	Blank without	L insert M3 O insert UNC 4.40	V Female screw UNC 4-40
PCB ACCESSORIES	A without	A without	A without

PART NUMBER	FRONT ACCESSORY	PCB ACCESSORY
D*xW xSA00LF	WITHOUT	WITHOUT
D*VxW xSA00LF	Female screw UNC 4-40	WITHOUT
D*LxW xSA00LF	Insert M3	WITHOUT
D*OxW xSA00LF	Insert UNC 4-40	WITHOUT

shell size LAYOUTS

E	2V2
A	3V3
A	3W3
B	5W5
C	8W8

SCALE:4

Amphenol
FCi

spec ref	dr Pro Engineer 1	2015/06/16	projection	mm	size A2	scale 2:1
tolerance std	eng J Dalbard	2016/09/13			ecn no	ECN-ELX-F-24942-1
TOLERANCES UNLESS OTHERWISE SPECIFIED	chr J Dalbard	2016/09/19				
	appr Aymeric Soudy	2016/09/20				
surface				Amphenol FCI	SUB FEMALE DW	dwg no C01-8639-2311
	linear	0.X ±0.3	0.XX ±0.10	0.XXX ±0.05	full power without contact	rev E
	angular	0°	±2°		cat. no.	Product - Customer Drw

PDS: Rev :E

STATUS:Released

Printed: Sep 28, 2016

© 2016 AFCI

FIRST ANGLE PROJECTION

2V2

3V3

3W3

FIRST ANGLE PROJECTION

B

C

D

E

F

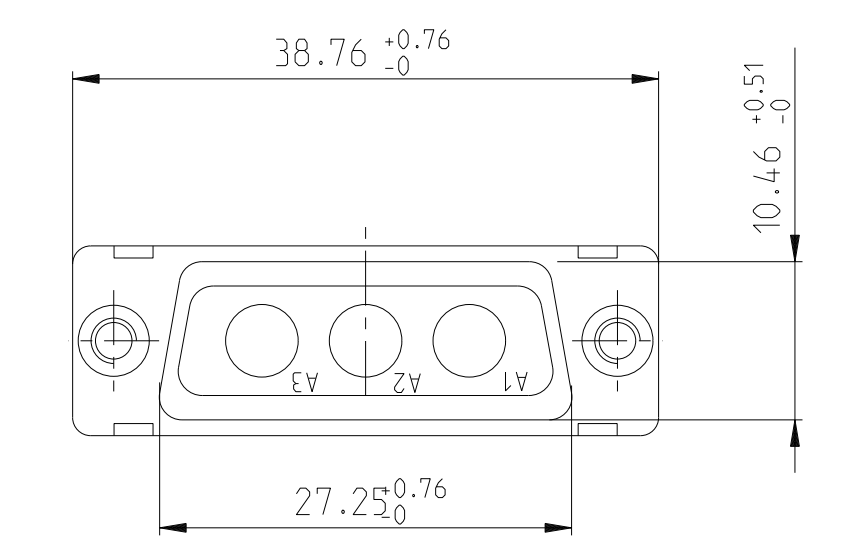
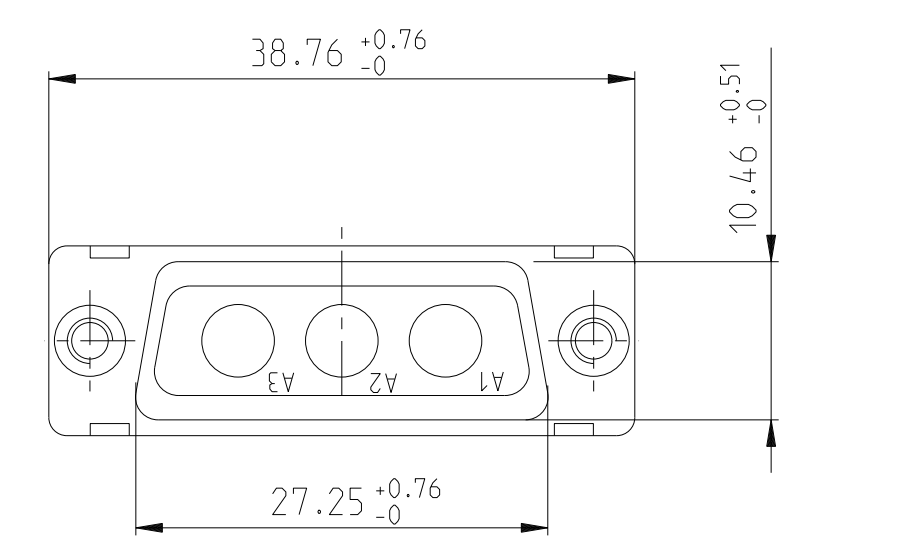
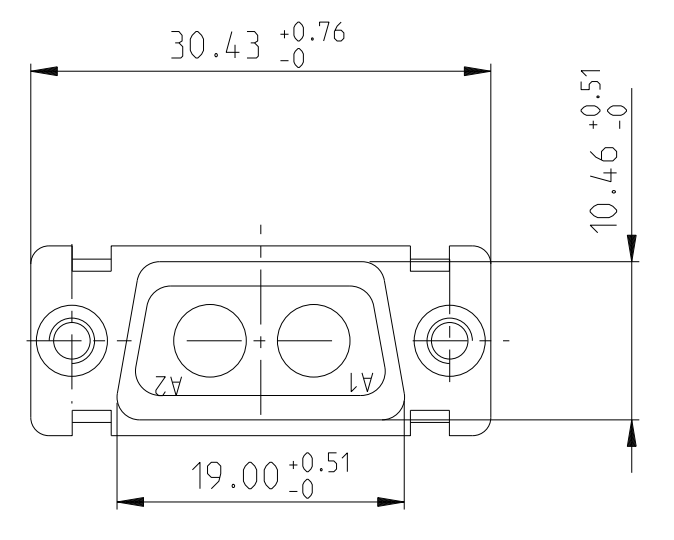
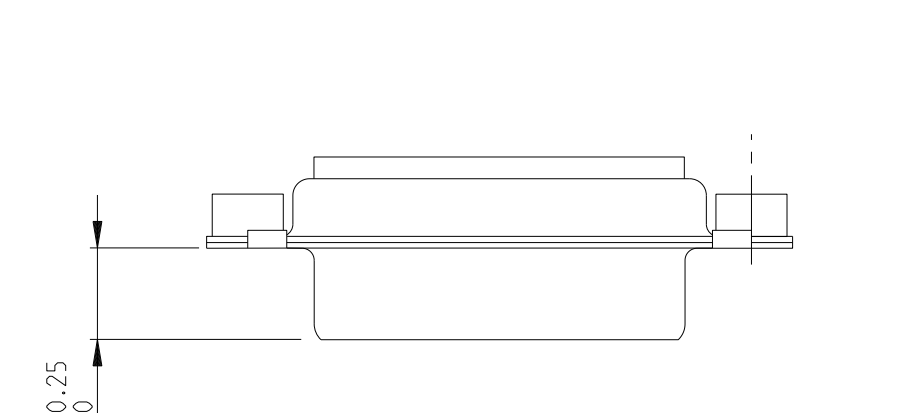
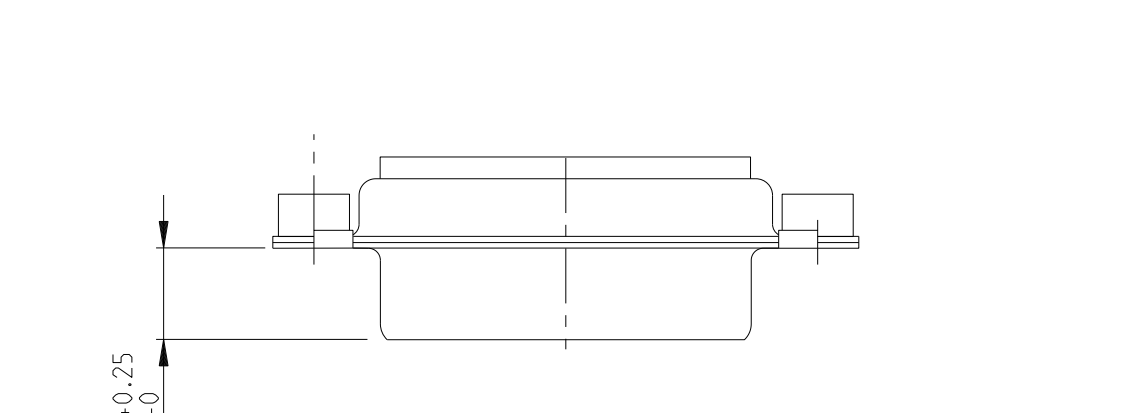
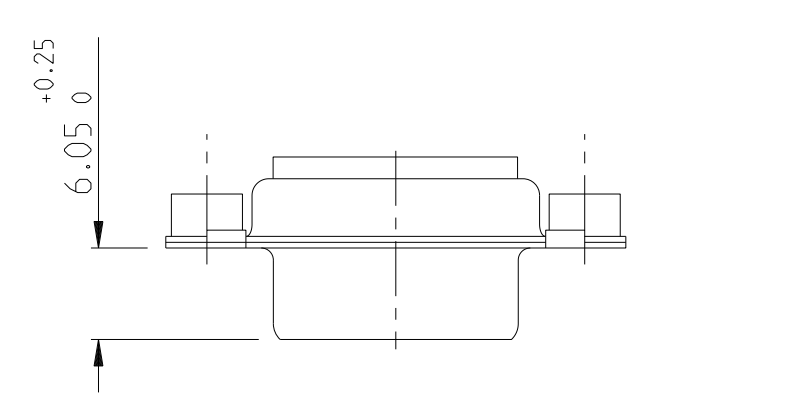
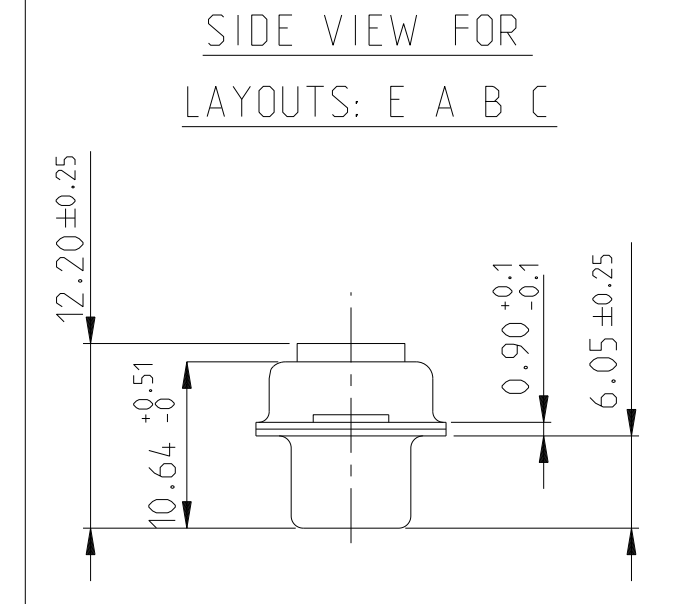
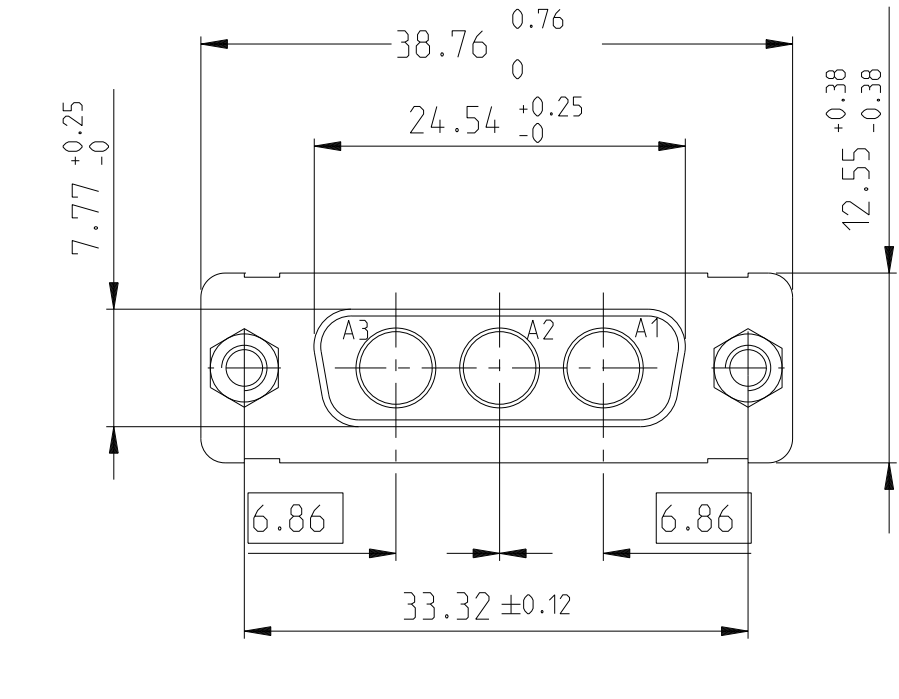
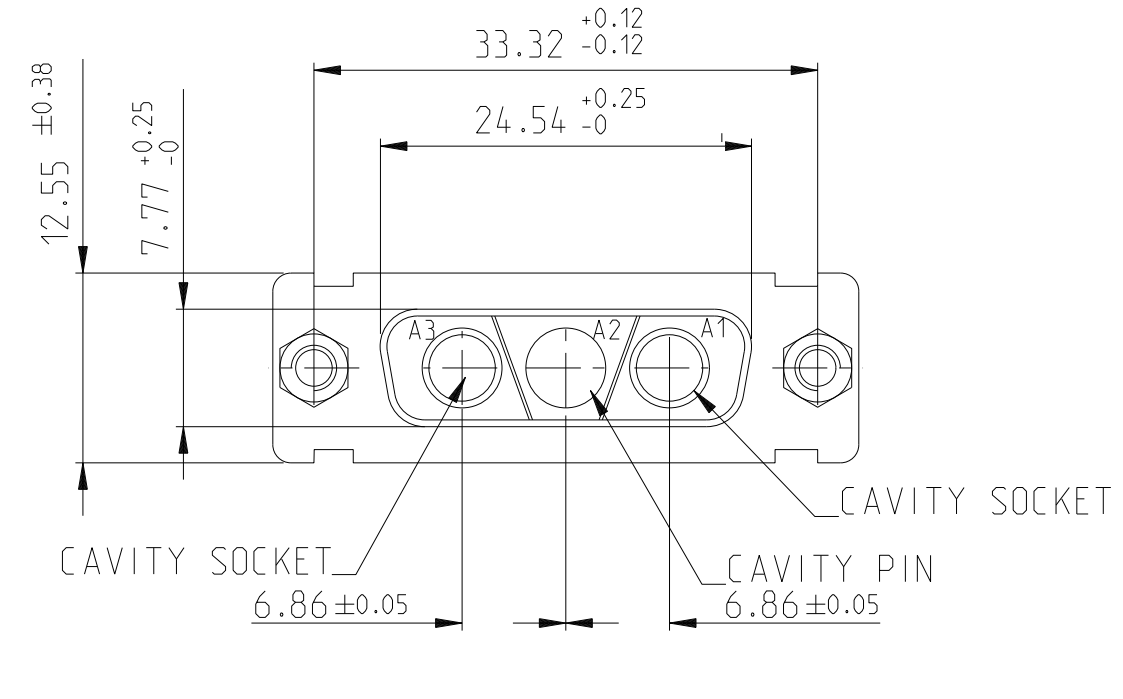
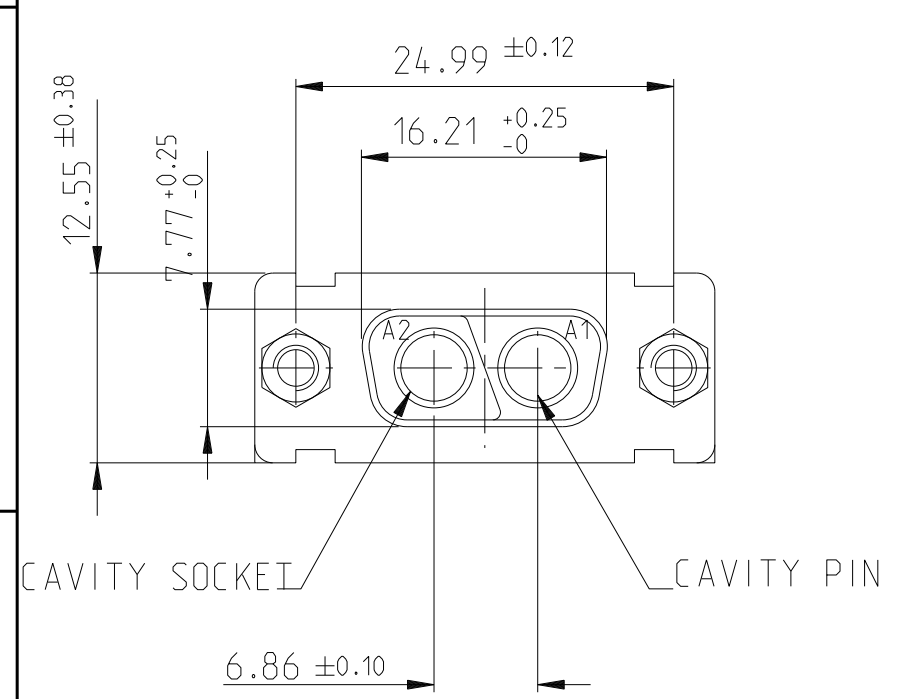

A

B

C

D

E

FIRST ANGLE PROJECTION

Amphenol FCI

© 2016 AFCI

spec ref	dr	Pro Engineer 1	2015/06/16	projection	mm	size	A2	scale	2:1	
tolerance std	eng	J Dalbard	2016/09/13	FIRST ANGLE PROJECTION	←	ecn no	ECN-ELX-F-24942-1			
TOLERANCES UNLESS OTHERWISE SPECIFIED	chr	J Dalbard	2016/09/19			rel level	Released			
	appr	Aymeric Soudy	2016/09/20			product family	-			
surface	linear	0.X	±0.3	Amphenol FCI	SUB FEMALE DW	cat. no.	-	Product - Customer Drw	sheet 3 of 4	
		0.XX	±0.10							
		0.XXX	±0.05							
	angular	0°	±2°							

PDS: Rev :E

STATUS:Released

Printed: Sep 28, 2016

FIRST ANGLE PROJECTION

B

C

D

E

F

5W5

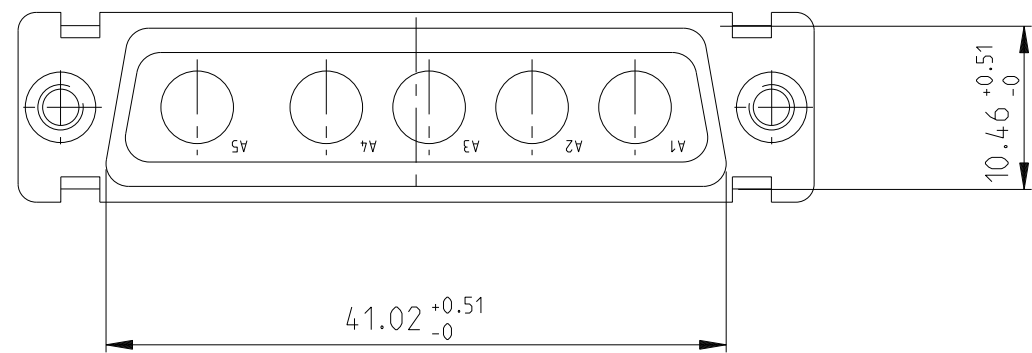
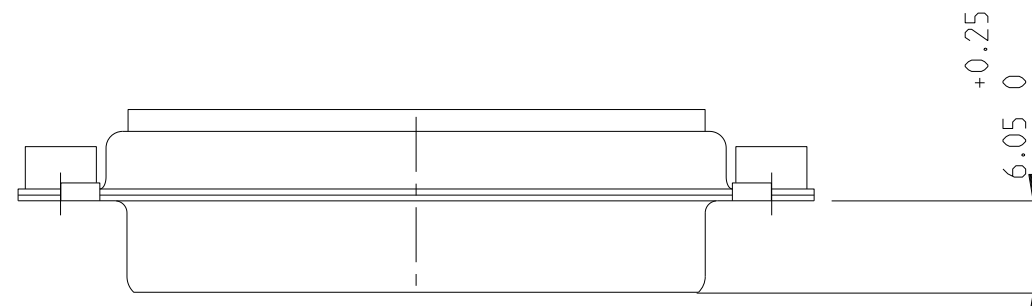
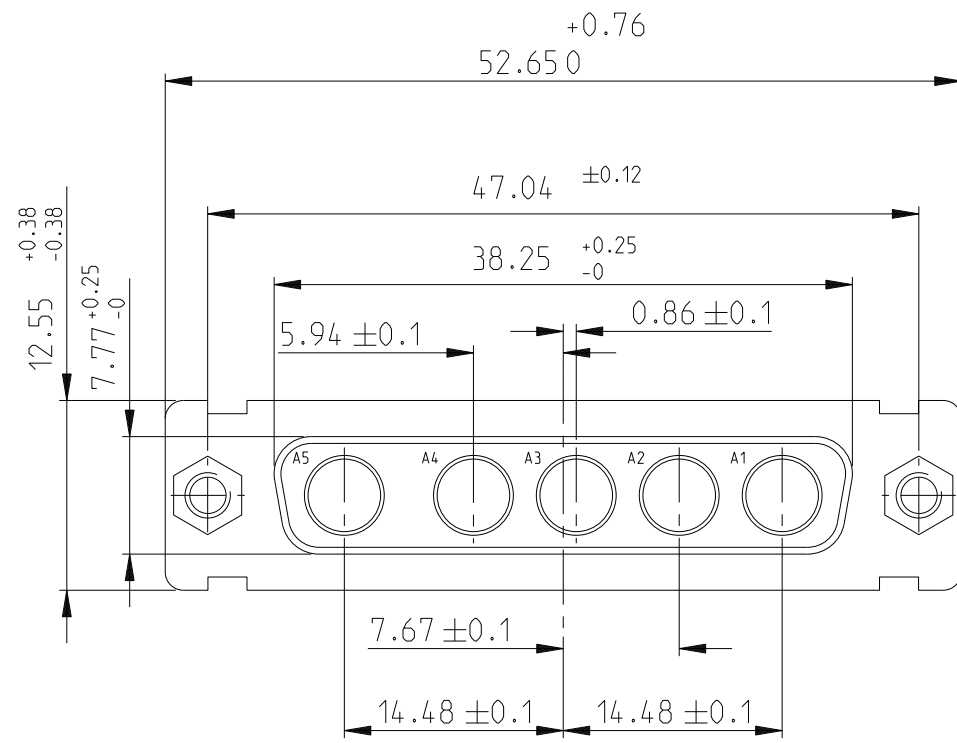

8W8

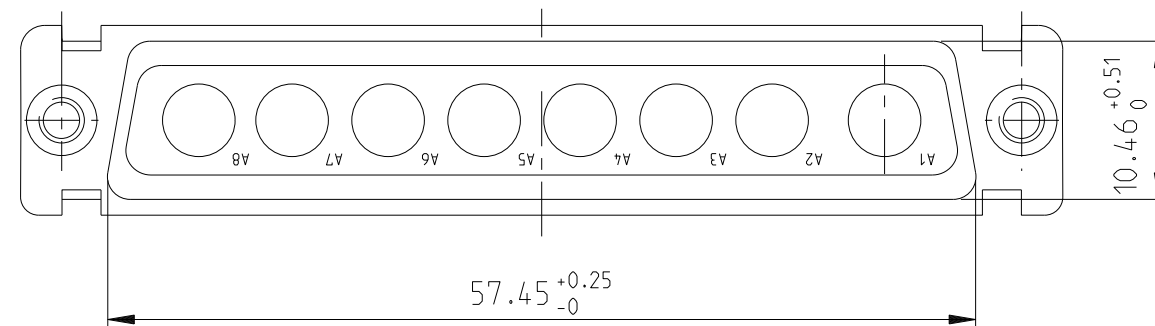
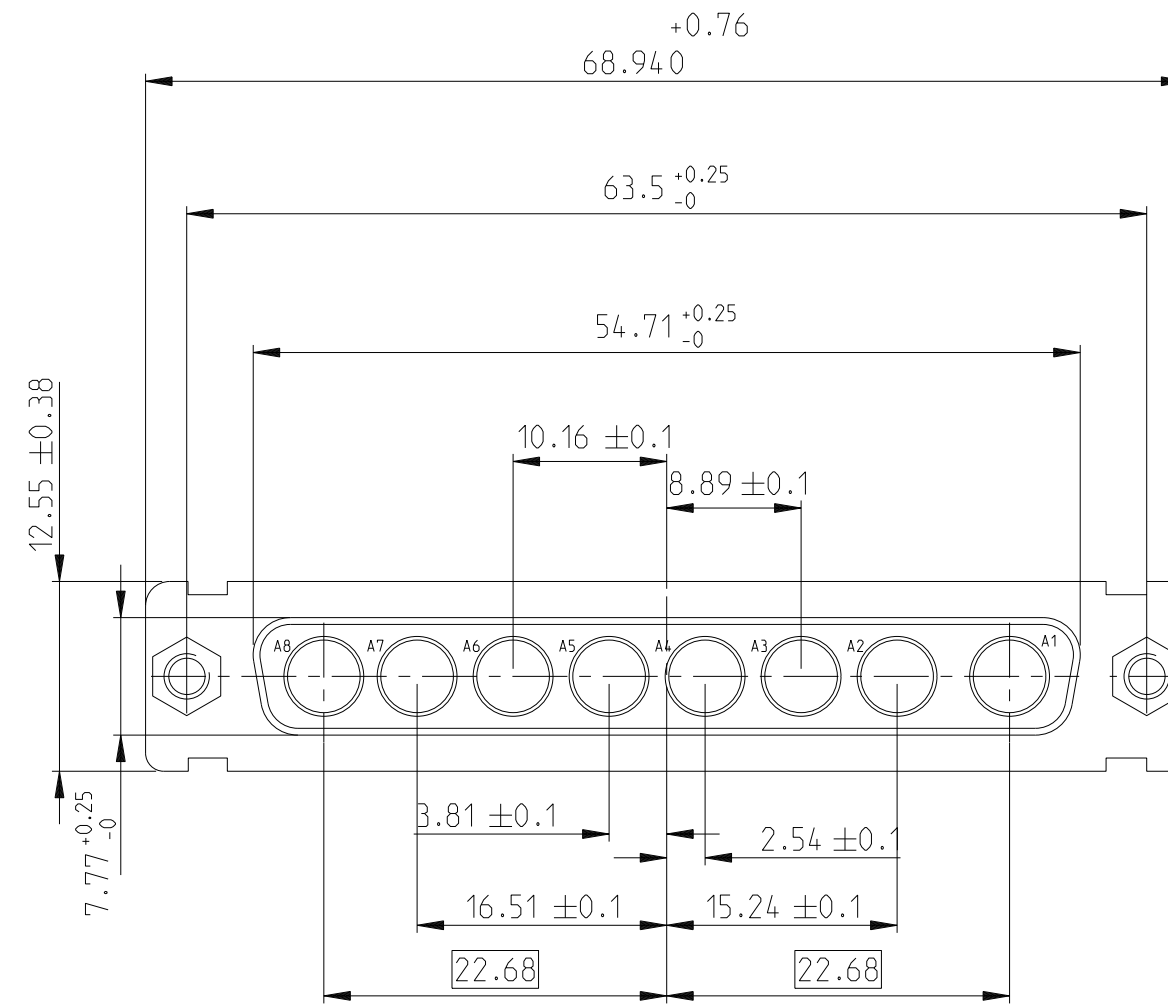

A

B

C

D

E

FIRST ANGLE PROJECTION

Amphenol FCI

© 2016 AFCI

spec ref	dr	Pro Engineer 1	2015/06/16	projection	mm	size	A2	scale	2:1
tolerance std	eng	J Dalbard	2016/09/13			ecn no	ECN-ELXF-24942-1	rel level	Released
TOLERANCES UNLESS OTHERWISE SPECIFIED	chr	J Dalbard	2016/09/19						
	appr	Aymeric Soudy	2016/09/20						
surface	linear	0.X	±0.3	product family	-	cat. no.	-	Product - Customer Drw	sheet 4 of 4
		0.XX	±0.10	Amphenol FCI	SUB FEMALE DW	dwg no	C01-8639-2311	rev	E
	angular	0.XXX	±0.05		full power without contact				
		0°	±2°						

PDS: Rev :E

STATUS:Released

Printed: Sep 28, 2016



Компания «ЭлектроПласт» предлагает заключение долгосрочных отношений при поставках импортных электронных компонентов на взаимовыгодных условиях!

Наши преимущества:

- Оперативные поставки широкого спектра электронных компонентов отечественного и импортного производства напрямую от производителей и с крупнейших мировых складов;
- Поставка более 17-ти миллионов наименований электронных компонентов;
- Поставка сложных, дефицитных, либо снятых с производства позиций;
- Оперативные сроки поставки под заказ (от 5 рабочих дней);
- Экспресс доставка в любую точку России;
- Техническая поддержка проекта, помощь в подборе аналогов, поставка прототипов;
- Система менеджмента качества сертифицирована по Международному стандарту ISO 9001;
- Лицензия ФСБ на осуществление работ с использованием сведений, составляющих государственную тайну;
- Поставка специализированных компонентов (Xilinx, Altera, Analog Devices, Intersil, Interpoint, Microsemi, Aeroflex, Peregrine, Syfer, Eurofarad, Texas Instrument, Miteq, Cobham, E2V, MA-COM, Hittite, Mini-Circuits, General Dynamics и др.);

Помимо этого, одним из направлений компании «ЭлектроПласт» является направление «Источники питания». Мы предлагаем Вам помощь Конструкторского отдела:

- Подбор оптимального решения, техническое обоснование при выборе компонента;
- Подбор аналогов;
- Консультации по применению компонента;
- Поставка образцов и прототипов;
- Техническая поддержка проекта;
- Защита от снятия компонента с производства.



Как с нами связаться

Телефон: 8 (812) 309 58 32 (многоканальный)

Факс: 8 (812) 320-02-42

Электронная почта: org@eplast1.ru

Адрес: 198099, г. Санкт-Петербург, ул. Калинина, дом 2, корпус 4, литера А.