LTC6363-1, LTC6363-2, LTC6363-0.5 Fully Differential Amplifier

DESCRIPTION

The LTC[®]6363-1, LTC6363-2, LTC6363-0.5 are low power, low noise differential op amps with built-in precision resistors to establish accurate gains of 1, 2 or 0.5 respectively.

The DC2655A is a small-size demo circuit that minimizes trace resistance in series with the IC, so that the precise gain and CMRR can be maintained. The board's inputs can be driven single-ended or differentially. The signal path from inputs to outputs is DC-coupled. An onboard jumper

configures the DC2655A for dual or single power supply. To minimize PCB layout parasitics, the configurability of this board has been minimized. For a more flexible board refer to the DC2319A.

Design files for this circuit board are available at <http://www.analog.com/DC2655A>

All registered trademarks and trademarks are the property of their respective owners.

Table 1. DC2655A Versions

PART NUMBER	DEMO CIRCUIT NUMBER	DESCRIPTION
LTC6363-1	DC2655A-A	Internal Gain Resistors G = 1
LTC6363-2	DC2655A-B	Internal Gain Resistors G = 2
LTC6363-05	DC2655A-C	Internal Gain Resistors G = 0.5

QUICK START PROCEDURE

Refer to Figure 1a. Check to ensure that jumper JP1 is set as shown (single supply). Power-up the DC2655A from a single power supply, $V^+ = 5V$ and $GND = 0V$. Connect V_{IN}^- to ground using E8. Connect an input voltage to V_{IN}^+ using E7. The differential output voltage can then be measured on V_{OUT}^- and V_{OUT}^+ (E9 and E10). The outputs will be level-shifted to be balanced symmetrical around

approximately 2.5V. The difference between the outputs will be the gain times the difference between the inputs.

For a similar setup using a split supply, change the setting of JP1 to dual supply, and connect a negative supply to V^- . See Figure 1b.

QUICK START PROCEDURE

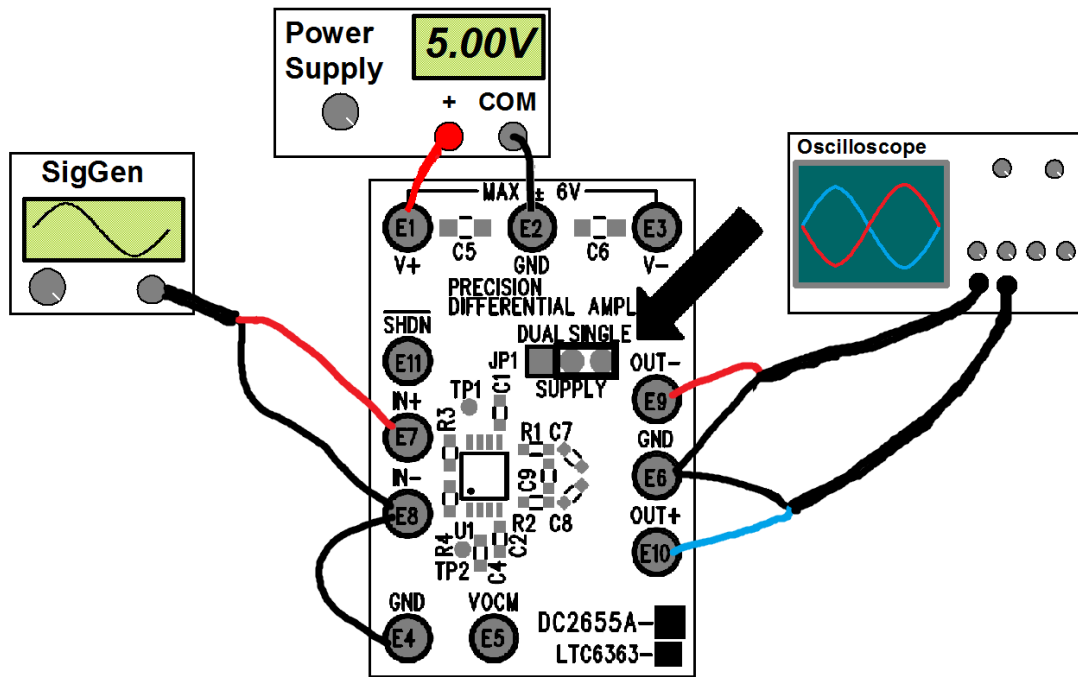

Figure 1a: DC2655A Connection Diagram (Single Supply)

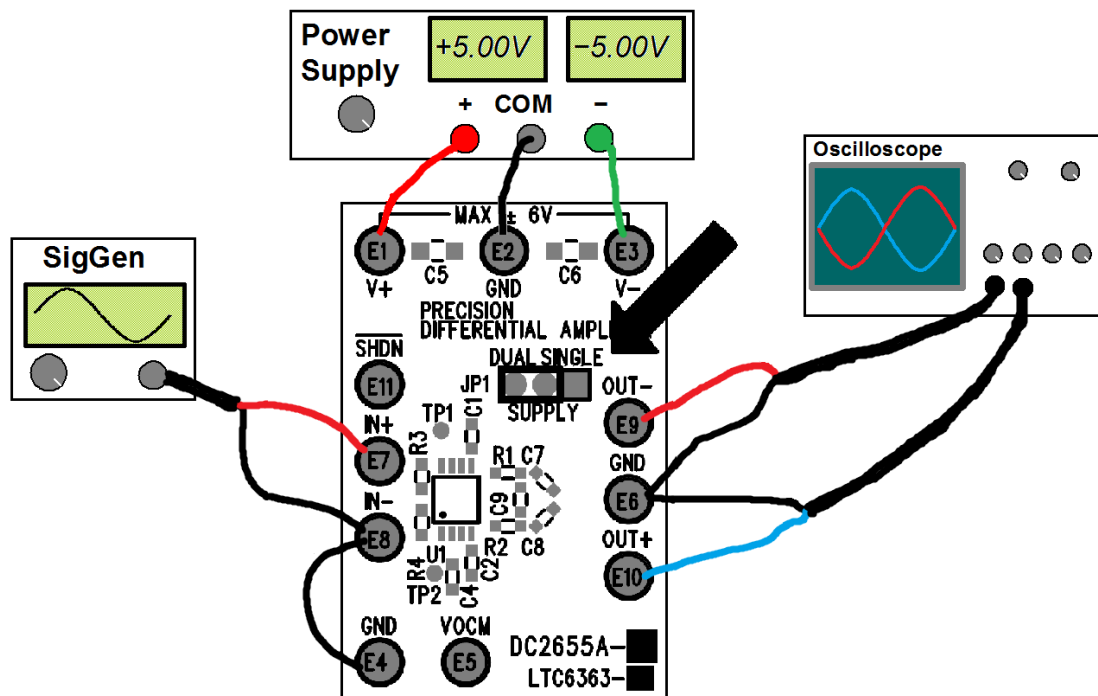

Figure 1b: DC2655A Connection Diagram (Dual Supply)

QUICK START PROCEDURE

Single-Ended Input to Differential Output

To configure the DC2655A for single-ended input to differential output, simply connect a DC bias (such as ground) to V_{IN}^- and connect the input signal to V_{IN}^+ . The differential output is measured on V_{OUT}^+ and V_{OUT}^- . The unused input can also be grounded on the board by populating R3 or R4.

Differential Input to Differential Output

To configure the DC2655A for differential input to differential output, simply connect the differential input signal to V_{IN}^+ and V_{IN}^- respectively. The differential output is measured on V_{OUT}^+ and V_{OUT}^- .

External Output Common Mode Adjust

The DC2655A is by default configured to bias the output common mode at the voltage determined by the LTC6363 IC, which is at approximately the mid-point between the amplifier's V^+ and V^- pins. (For example, if single supply is used, the output common mode will be at half the V^+ voltage).

To set a different value for the output common mode voltage, apply the desired DC bias to the VOCM pin at E5. This will overdrive the on-chip resistor dividers.

Output Filter

The DC2655A is configured by default without filtering at the input or output. To install an onboard lowpass filter, populate C7, C8, and/or C9 and replace the 0Ω R1/R2 with appropriate resistor values.

Layout

The DC2655A PCB layout demonstrates the known best-practices of pcb layout to get the best performance out of the LTC6363. A ground plane is used, and supply bypass capacitors are close to the supply pins. Use a symmetrical layout around the analog inputs and outputs to minimize

the effects of parasitic elements. However, the DC2655A is designed to accommodate both single supply and dual supply circuits. A PCB design for a single supply application would connect the amplifier's V^- pin directly to the copper ground plane and use only one supply bypass capacitor directly between V^+ and ground.

Connectors and Jumpers

JP1: Jumper toggles the SUPPLY between DUAL and SINGLE power supplies. If set to dual supply, connect a negative supply voltage to V^- .

V^+ : Connect to Positive Power Supply.

GND: Connect to Ground. Available at multiple turrets on the board, all shorted together internally. Only need to connect one, others can be used as ground point for measurements.

V^- : Negative Power Supply voltage. No need to connect if JP2 is set to single supply.

SHDN: Externally drives the SHDN pin. No need to connect, unless desired to turn the amplifier ON and OFF with a logic signal. (See LTC6363 data sheet for logic levels.)

VOCM: Externally drives the VOCM pin. The voltage on this pin sets the output common mode voltage level. If left floating (default setting), then an internal resistor divider develops a voltage that is approximately midway between the LTC6363 V^+ and V^- supply rails.

IN $^+$: Connect noninverting input signal voltage to the amplifier circuit.

IN $^-$: Connect inverting input signal voltage to the amplifier circuit.

OUT $^-$: Measure inverting output signal voltage from the amplifier circuit.

OUT $^+$: Measure noninverting output signal voltage from the amplifier circuit.



ESD Caution

ESD (electrostatic discharge) sensitive device. Charged devices and circuit boards can discharge without detection. Although this product features patented or proprietary protection circuitry, damage may occur on devices subjected to high energy ESD. Therefore, proper ESD precautions should be taken to avoid performance degradation or loss of functionality.

Legal Terms and Conditions

By using the evaluation board discussed herein (together with any tools, components documentation or support materials, the "Evaluation Board"), you are agreeing to be bound by the terms and conditions set forth below ("Agreement") unless you have purchased the Evaluation Board, in which case the Analog Devices Standard Terms and Conditions of Sale shall govern. Do not use the Evaluation Board until you have read and agreed to the Agreement. Your use of the Evaluation Board shall signify your acceptance of the Agreement. This Agreement is made by and between you ("Customer") and Analog Devices, Inc. ("ADI"), with its principal place of business at One Technology Way, Norwood, MA 02062, USA. Subject to the terms and conditions of the Agreement, ADI hereby grants to Customer a free, limited, personal, temporary, non-exclusive, non-sublicensable, non-transferable license to use the Evaluation Board FOR EVALUATION PURPOSES ONLY. Customer understands and agrees that the Evaluation Board is provided for the sole and exclusive purpose referenced above, and agrees not to use the Evaluation Board for any other purpose. Furthermore, the license granted is expressly made subject to the following additional limitations: Customer shall not (i) rent, lease, display, sell, transfer, assign, sublicense, or distribute the Evaluation Board; and (ii) permit any Third Party to access the Evaluation Board. As used herein, the term "Third Party" includes any entity other than ADI, Customer, their employees, affiliates and in-house consultants. The Evaluation Board is NOT sold to Customer; all rights not expressly granted herein, including ownership of the Evaluation Board, are reserved by ADI. CONFIDENTIALITY. This Agreement and the Evaluation Board shall all be considered the confidential and proprietary information of ADI. Customer may not disclose or transfer any portion of the Evaluation Board to any other party for any reason. Upon discontinuation of use of the Evaluation Board or termination of this Agreement, Customer agrees to promptly return the Evaluation Board to ADI. ADDITIONAL RESTRICTIONS. Customer may not disassemble, decompile or reverse engineer chips on the Evaluation Board. Customer shall inform ADI of any occurred damages or any modifications or alterations it makes to the Evaluation Board, including but not limited to soldering or any other activity that affects the material content of the Evaluation Board. Modifications to the Evaluation Board must comply with applicable law, including but not limited to the RoHS Directive. TERMINATION. ADI may terminate this Agreement at any time upon giving written notice to Customer. Customer agrees to return to ADI the Evaluation Board at that time. LIMITATION OF LIABILITY. THE EVALUATION BOARD PROVIDED HEREUNDER IS PROVIDED "AS IS" AND ADI MAKES NO WARRANTIES OR REPRESENTATIONS OF ANY KIND WITH RESPECT TO IT. ADI SPECIFICALLY DISCLAIMS ANY REPRESENTATIONS, ENDORSEMENTS, GUARANTEES, OR WARRANTIES, EXPRESS OR IMPLIED, RELATED TO THE EVALUATION BOARD INCLUDING, BUT NOT LIMITED TO, THE IMPLIED WARRANTY OF MERCHANTABILITY, TITLE, FITNESS FOR A PARTICULAR PURPOSE OR NON-INFRINGEMENT OF INTELLECTUAL PROPERTY RIGHTS. IN NO EVENT WILL ADI AND ITS LICENSORS BE LIABLE FOR ANY INCIDENTAL, SPECIAL, INDIRECT, OR CONSEQUENTIAL DAMAGES RESULTING FROM CUSTOMER'S POSSESSION OR USE OF THE EVALUATION BOARD, INCLUDING BUT NOT LIMITED TO LOST PROFITS, DELAY COSTS, LABOR COSTS OR LOSS OF GOODWILL. ADI'S TOTAL LIABILITY FROM ANY AND ALL CAUSES SHALL BE LIMITED TO THE AMOUNT OF ONE HUNDRED US DOLLARS (\$100.00). EXPORT. Customer agrees that it will not directly or indirectly export the Evaluation Board to another country, and that it will comply with all applicable United States federal laws and regulations relating to exports. GOVERNING LAW. This Agreement shall be governed by and construed in accordance with the substantive laws of the Commonwealth of Massachusetts (excluding conflict of law rules). Any legal action regarding this Agreement will be heard in the state or federal courts having jurisdiction in Suffolk County, Massachusetts, and Customer hereby submits to the personal jurisdiction and venue of such courts. The United Nations Convention on Contracts for the International Sale of Goods shall not apply to this Agreement and is expressly disclaimed.



Компания «ЭлектроПласт» предлагает заключение долгосрочных отношений при поставках импортных электронных компонентов на взаимовыгодных условиях!

Наши преимущества:

- Оперативные поставки широкого спектра электронных компонентов отечественного и импортного производства напрямую от производителей и с крупнейших мировых складов;
- Поставка более 17-ти миллионов наименований электронных компонентов;
- Поставка сложных, дефицитных, либо снятых с производства позиций;
- Оперативные сроки поставки под заказ (от 5 рабочих дней);
- Экспресс доставка в любую точку России;
- Техническая поддержка проекта, помощь в подборе аналогов, поставка прототипов;
- Система менеджмента качества сертифицирована по Международному стандарту ISO 9001;
- Лицензия ФСБ на осуществление работ с использованием сведений, составляющих государственную тайну;
- Поставка специализированных компонентов (Xilinx, Altera, Analog Devices, Intersil, Interpoint, Microsemi, Aeroflex, Peregrine, Syfer, Eurofarad, Texas Instrument, Miteq, Cobham, E2V, MA-COM, Hittite, Mini-Circuits, General Dynamics и др.);

Помимо этого, одним из направлений компании «ЭлектроПласт» является направление «Источники питания». Мы предлагаем Вам помощь Конструкторского отдела:

- Подбор оптимального решения, техническое обоснование при выборе компонента;
- Подбор аналогов;
- Консультации по применению компонента;
- Поставка образцов и прототипов;
- Техническая поддержка проекта;
- Защита от снятия компонента с производства.



Как с нами связаться

Телефон: 8 (812) 309 58 32 (многоканальный)

Факс: 8 (812) 320-02-42

Электронная почта: org@eplast1.ru

Адрес: 198099, г. Санкт-Петербург, ул. Калинина, дом 2, корпус 4, литера А.