

SUBMINIATURE DB Series

Features

- High-precision switch with high repeat accuracy
- Models available for operating temperatures up to 120°C
- Rated for currents up to 10 amp at 250VAC
- Range of auxiliary actuators available (can also be retrofitted); two mounting positions
- Variety of contact materials available to suit your application
- Mechanical life: up to 15 x 10⁶ operations
- Wide variety of terminal types available
- Numerous approvals



Electrical Ratings

Switch Series	EN61058 Rating	UL1054 Rating	Electrical Life at Rated Load	
			According to EN (Min. Operations)	According to UL (Min. Operations)
DB1	6A, 250V~	5A, 125/250VAC	10,000	6,000
DB2	10(1.5)A, 250V~	10.1A, 125/250VAC; 1/4HP, 125VAC	10,000	6,000
DB3	0.1A, 250V~	0.1A, 125/250VAC	50,000	6,000
DB5*	1A, 250V~	1A, 125/250VAC	50,000	6,000
DB6*	6A, 250V~	5A, 125/250VAC	50,000	6,000
DB7*	10(1.5A), 400V~	10.1A, 125/250VAC; 1/4HP, 125VAC	50,000	6,000

*85°C

Specifications

Electrical

Temperature Rating: -40°C to +85°C / +120°C

Flammability Rating: UL94V-O (PBT, PET)
UL94HB (POM)

Materials

Base: PET

Cover: PBT

Actuator: PBT, POM

Auxiliary Actuator: Stainless Steel or Plastic

Terminals: Silver-Plated Copper-Zinc

Contacts: Silver Alloy
Gold Crosspoint

PBT = Polybutyleneterephthalate • PET = Polyethyleneterephthalate • POM = Polyacetal



Dimensions inches (mm)

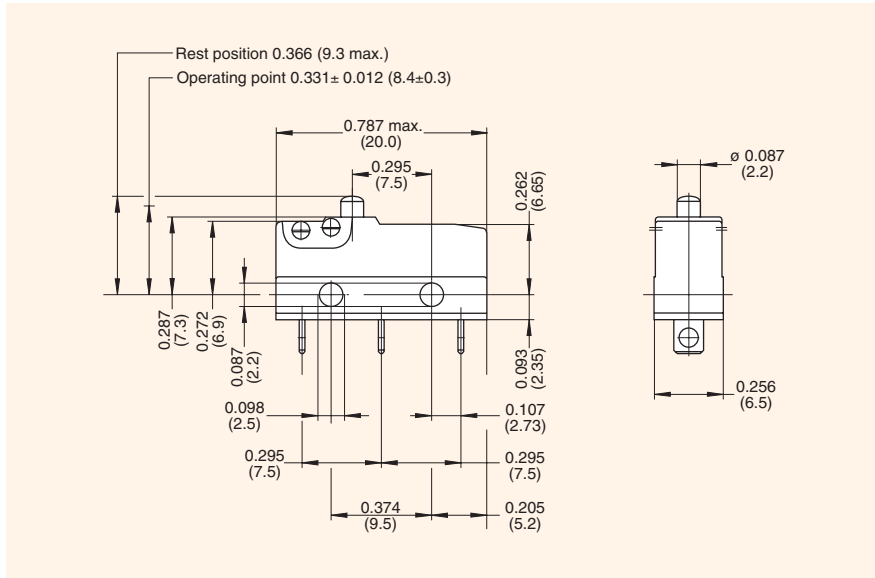

Terminal Options inches (mm)

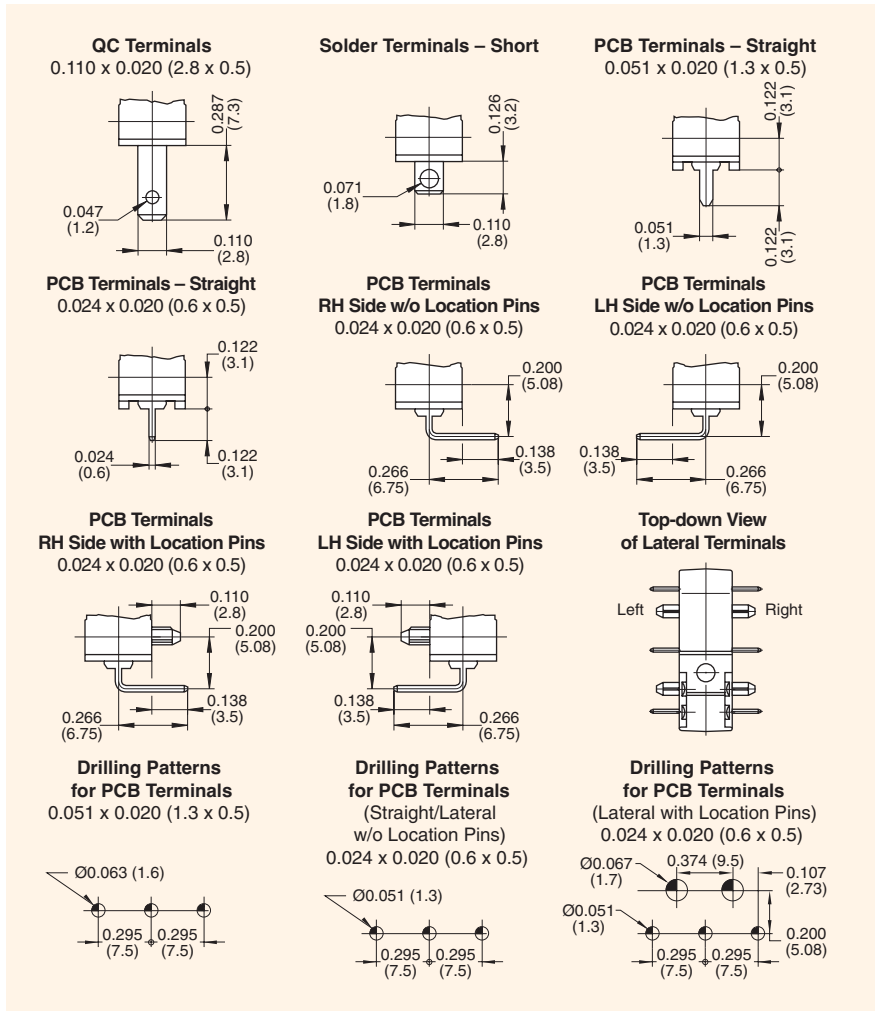

Auxiliary Actuator inches (mm)

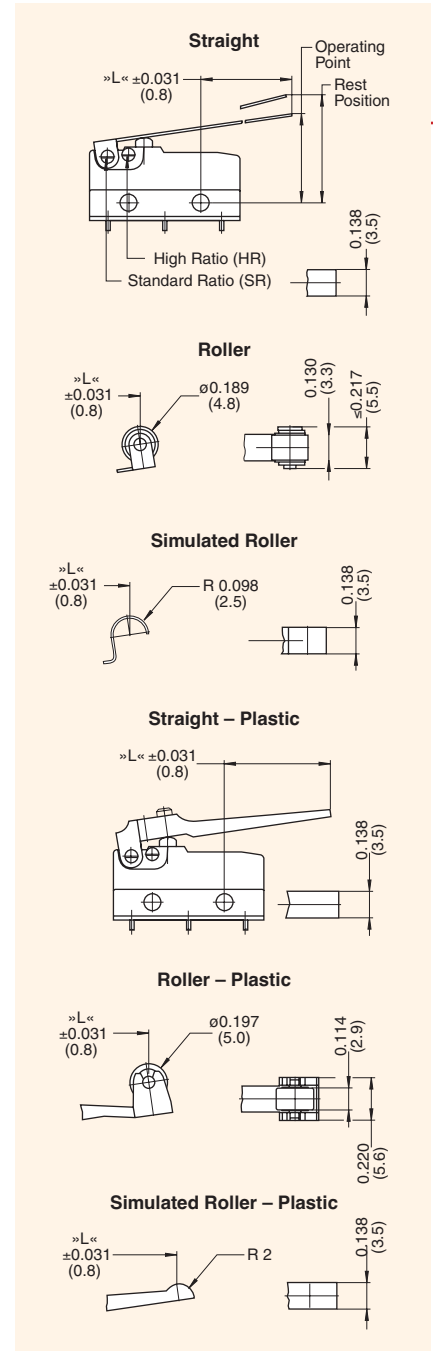

Contact Ratings at Direct Voltage

Switching Voltage	Switched Current Resistive Load		Inductive Load L/R=3ms	
	DB1	DB2	DB1	DB2
12V	6A	10A	6A	10A
24V	3A	5A	2A	4A
60V	1A	1A	0.5A	0.5A
110V	0.5A	0.5A	0.2A	0.2A
220V	0.25A	0.25A	0.1A	0.1A

Actuator Specifications — Standard Ratio

Actuator Code	Switch Type	Maximum Operating Force (gms.)	Maximum Pre-Travel inches (mm)	Operating Point inches (mm)	Minimum Over-Travel inches (mm)	Max. Movement Differential inches (mm)	Max. Rest Position inches (mm)	Actuation Length inches (mm)	
AA		DB5	70	0.039 (1.0)	0.331±0.012 (8.4±0.3)	0.024 (0.6)	0.004 (0.10)	0.366 (9.3)	—
		DB1/3	150	0.039 (1.0)	0.331±0.012 (8.4±0.3)	0.024 (0.6)	0.004 (0.10)	0.366 (9.3)	—
		DB6	150	0.039 (1.0)	0.331±0.012 (8.4±0.3)	0.024 (0.6)	0.006 (0.15)	0.366 (9.3)	—
		DB2	250	0.039 (1.0)	0.331±0.012 (8.4±0.3)	0.024 (0.6)	0.004 (0.10)	0.366 (9.3)	—
		DB7	280	0.039 (1.0)	0.331±0.012 (8.4±0.3)	0.024 (0.6)	0.006 (0.15)	0.366 (9.3)	—
BA		DB5	70	0.039 (1.0)	0.331±0.012 (8.4±0.3)	0.024 (0.6)	0.004 (0.10)	0.366 (9.3)	—
		DB1/3	150	0.039 (1.0)	0.331±0.012 (8.4±0.3)	0.024 (0.6)	0.004 (0.10)	0.366 (9.3)	—
		DB6	250	0.039 (1.0)	0.331±0.012 (8.4±0.3)	0.024 (0.6)	0.006 (0.15)	0.366 (9.3)	—
		DB2	250	0.039 (1.0)	0.331±0.012 (8.4±0.3)	0.024 (0.6)	0.004 (0.10)	0.366 (9.3)	—
		DB7	280	0.039 (1.0)	0.331±0.012 (8.4±0.3)	0.024 (0.6)	0.006 (0.15)	0.366 (9.3)	—
<i>Auxiliary actuator, rear-mounted (RM)</i>									
LB		DB5	30	0.157 (4.0)	0.421±0.051 (10.7±1.3)	0.079 (2.0)	0.020 (0.5)	0.551 (14.0)	0.189 (4.8)
		DB1/3	60	0.157 (4.0)	0.421±0.051 (10.7±1.3)	0.079 (2.0)	0.020 (0.5)	0.551 (14.0)	0.189 (4.8)
		DB6	60	0.157 (4.0)	0.421±0.051 (10.7±1.3)	0.079 (2.0)	0.030 (0.75)	0.551 (14.0)	0.189 (4.8)
		DB2	100	0.177 (4.5)	0.421±0.063 (10.7±1.6)	0.059 (1.5)	0.028 (0.70)	0.551 (14.0)	0.189 (4.8)
		DB7	115	0.177 (4.5)	0.421±0.063 (10.7±1.6)	0.059 (1.5)	0.030 (0.75)	0.551 (14.0)	0.189 (4.8)
LC		DB5	25	0.177 (4.5)	0.437±0.059 (11.1±1.5)	0.079 (2.0)	0.024 (0.6)	0.591 (15.0)	0.276 (7.0)
		DB1/3	50	0.177 (4.5)	0.437±0.059 (11.1±1.5)	0.079 (2.0)	0.024 (0.6)	0.591 (15.0)	0.276 (7.0)
		DB6	50	0.177 (4.5)	0.437±0.059 (11.1±1.5)	0.079 (2.0)	0.047 (1.2)	0.591 (15.0)	0.276 (7.0)
		DB2	85	0.197 (5.0)	0.437±0.071 (11.1±1.8)	0.059 (1.5)	0.039 (1.0)	0.591 (15.0)	0.276 (7.0)
		DB7	100	0.197 (5.0)	0.437±0.071 (11.1±1.8)	0.059 (1.5)	0.047 (1.2)	0.591 (15.0)	0.276 (7.0)
LD		DB5	9	0.591 (15.0)	0.512±0.138 (13.0±3.5)	0.157 (4.0)	0.177 (4.5)	1.063 (27.0)	1.654 (42.0)
		DB1/3	18	0.591 (15.0)	0.512±0.138 (13.0±3.5)	0.157 (4.0)	0.177 (4.5)	1.063 (27.0)	1.654 (42.0)
		DB6	18	0.591 (15.0)	0.512±0.138 (13.0±3.5)	0.157 (4.0)	0.268 (6.8)	1.063 (27.0)	1.654 (42.0)
		DB2/7	—	—	—	—	—	—	on request
SB		DB5	30	0.157 (4.0)	0.630±0.051 (16.0±1.3)	0.079 (2.0)	0.020 (0.5)	0.748 (19.0)	0.098 (2.5)
		DB1/3	65	0.157 (4.0)	0.630±0.051 (16.0±1.3)	0.079 (2.0)	0.020 (0.5)	0.748 (19.0)	0.098 (2.5)
		DB6	65	0.157 (4.0)	0.630±0.051 (16.0±1.3)	0.079 (2.0)	0.043 (1.1)	0.748 (19.0)	0.098 (2.5)
		DB2	110	0.177 (4.5)	0.630±0.063 (16.0±1.6)	0.059 (1.5)	0.028 (0.7)	0.748 (19.0)	0.098 (2.5)
		DB7	125	0.177 (4.5)	0.630±0.063 (16.0±1.6)	0.059 (1.5)	0.043 (1.1)	0.748 (19.0)	0.098 (2.5)
SC		DB5	25	0.177 (4.5)	0.646±0.059 (16.4±1.5)	0.079 (2.0)	0.024 (0.6)	0.787 (20.0)	0.185 (4.7)
		DB1/3	55	0.177 (4.5)	0.646±0.059 (16.4±1.5)	0.079 (2.0)	0.024 (0.6)	0.787 (20.0)	0.185 (4.7)
		DB6	55	0.177 (4.5)	0.646±0.059 (16.4±1.5)	0.079 (2.0)	0.047 (1.2)	0.787 (20.0)	0.185 (4.7)
		DB2	95	0.197 (5.0)	0.646±0.071 (16.4±1.8)	0.059 (1.5)	0.039 (1.0)	0.787 (20.0)	0.185 (4.7)
		DB7	110	0.197 (5.0)	0.646±0.071 (16.4±1.8)	0.059 (1.5)	0.047 (1.2)	0.787 (20.0)	0.185 (4.7)
SD		DB5	9	0.591 (15.0)	0.720±0.138 (18.3±3.5)	0.157 (4.0)	0.177 (4.5)	1.260 (32.0)	1.563 (39.7)
		DB1/3	20	0.591 (15.0)	0.720±0.138 (18.3±3.5)	0.157 (4.0)	0.177 (4.5)	1.260 (32.0)	1.563 (39.7)
		DB6	20	0.591 (15.0)	0.720±0.138 (18.3±3.5)	0.157 (4.0)	0.268 (6.8)	1.260 (32.0)	1.563 (39.7)
		DB2/7	—	—	—	—	—	—	on request
RB		DB5	30	0.157 (4.0)	0.622±0.051 (15.8±1.3)	0.079 (2.0)	0.020 (0.5)	0.748 (19.0)	0.098 (2.5)
		DB1/3	65	0.157 (4.0)	0.622±0.051 (15.8±1.3)	0.079 (2.0)	0.020 (0.5)	0.748 (19.0)	0.098 (2.5)
		DB6	65	0.157 (4.0)	0.622±0.051 (15.8±1.3)	0.079 (2.0)	0.030 (0.75)	0.748 (19.0)	0.098 (2.5)
		DB2	110	0.177 (4.5)	0.622±0.063 (15.8±1.6)	0.059 (1.5)	0.028 (0.7)	0.748 (19.0)	0.098 (2.5)
		DB7	125	0.177 (4.5)	0.622±0.063 (15.8±1.6)	0.059 (1.5)	0.030 (0.75)	0.748 (19.0)	0.098 (2.5)
RC		DB5	25	0.177 (4.5)	0.638±0.059 (16.2±1.5)	0.079 (2.0)	0.024 (0.6)	0.787 (20.0)	0.185 (4.7)
		DB1/3	55	0.177 (4.5)	0.638±0.059 (16.2±1.5)	0.079 (2.0)	0.024 (0.6)	0.787 (20.0)	0.185 (4.7)
		DB6	55	0.177 (4.5)	0.638±0.059 (16.2±1.5)	0.079 (2.0)	0.047 (1.2)	0.787 (20.0)	0.185 (4.7)
		DB2	95	0.197 (5.0)	0.638±0.071 (16.2±1.8)	0.059 (1.5)	0.039 (1.0)	0.787 (20.0)	0.185 (4.7)
		DB7	110	0.197 (5.0)	0.638±0.071 (16.2±1.8)	0.059 (1.5)	0.047 (1.2)	0.787 (20.0)	0.185 (4.7)
RD		DB5	9	0.591 (15.0)	0.713±0.138 (18.1±3.5)	0.157 (4.0)	0.177 (4.5)	1.260 (32.0)	1.563 (39.7)
		DB1/3	20	0.591 (15.0)	0.713±0.138 (18.1±3.5)	0.157 (4.0)	0.177 (4.5)	1.260 (32.0)	1.563 (39.7)
		DB6	20	0.591 (15.0)	0.713±0.138 (18.1±3.5)	0.157 (4.0)	0.268 (6.8)	1.260 (32.0)	1.563 (39.7)
		DB2/7	—	—	—	—	—	—	on request
WB*		DB5	24	0.177 (4.5)	0.437±0.059 (11.1±1.5)	0.079 (2.0)	0.024 (0.6)	0.591 (15.0)	0.276 (7.0)
		DB1/3	50	0.177 (4.5)	0.437±0.059 (11.1±1.5)	0.079 (2.0)	0.024 (0.6)	0.591 (15.0)	0.276 (7.0)
		DB6	50	0.177 (4.5)	0.437±0.059 (11.1±1.5)	0.079 (2.0)	0.035 (0.9)	0.591 (15.0)	0.276 (7.0)
		DB2	85	0.177 (4.5)	0.437±0.059 (11.1±1.5)	0.079 (2.0)	0.024 (0.6)	0.591 (15.0)	0.276 (7.0)
		DB7	100	0.177 (4.5)	0.437±0.059 (11.1±1.5)	0.079 (2.0)	0.035 (0.9)	0.591 (15.0)	0.276 (7.0)
WC*		DB5	18	0.236 (6.0)	0.480±0.071 (12.2±1.8)	0.118 (3.0)	0.031 (0.8)	0.669 (17.0)	0.551 (14.0)
		DB1/3	38	0.236 (6.0)	0.480±0.071 (12.2±1.8)	0.118 (3.0)	0.031 (0.8)	0.669 (17.0)	0.551 (14.0)
		DB6	38	0.236 (6.0)	0.480±0.071 (12.2±1.8)	0.118 (3.0)	0.047 (1.2)	0.669 (17.0)	0.551 (14.0)
		DB2	63	0.236 (6.0)	0.480±0.071 (12.2±1.8)	0.118 (3.0)	0.031 (0.8)	0.669 (17.0)	0.551 (14.0)
		DB7	75	0.236 (6.0)	0.480±0.071 (12.2±1.8)	0.118 (3.0)	0.047 (1.2)	0.669 (17.0)	0.551 (14.0)
VB*		DB5	25	0.177 (4.5)	0.469±0.055 (11.9±1.4)	0.079 (2.0)	0.024 (0.6)	0.591 (15.0)	0.220 (5.6)
		DB1/3	55	0.177 (4.5)	0.469±0.055 (11.9±1.4)	0.079 (2.0)	0.024 (0.6)	0.591 (15.0)	0.220 (5.6)
		DB6	55	0.177 (4.5)	0.469±0.055 (11.9±1.4)	0.079 (2.0)	0.035 (0.9)	0.591 (15.0)	0.220 (5.6)
		DB2	90	0.177 (4.5)	0.469±0.055 (11.9±1.4)	0.079 (2.0)	0.024 (0.6)	0.591 (15.0)	0.220 (5.6)
		DB7	105	0.177 (4.5)	0.469±0.055 (11.9±1.4)	0.079 (2.0)	0.035 (0.9)	0.591 (15.0)	0.220 (5.6)
ZB*		DB5	25	0.177 (4.5)	0.630±0.055 (16.0±1.4)	0.059 (1.5)	0.024 (0.6)	0.748 (19.0)	0.205 (5.2)
		DB1/3	55	0.177 (4.5)	0.630±0.055 (16.0±1.4)	0.059 (1.5)	0.024 (0.6)	0.748 (19.0)	0.205 (5.2)
		DB6	55	0.177 (4.5)	0.630±0.055 (16.0±1.4)	0.059 (1.5)	0.035 (0.9)	0.748 (19.0)	0.205 (5.2)
		DB2	90	0.177 (4.5)	0.630±0.055 (16.0±1.4)	0.059 (1.5)	0.024 (0.6)	0.748 (19.0)	0.205 (5.2)
		DB7	105	0.177 (4.5)	0.630±0.055 (16.0±1.4)	0.059 (1.5)	0.035 (0.9)	0.748 (19.0)	0.205 (5.2)

*For 85°C only

Actuator Specifications — High Ratio

Actuator Code	Switch Type	Maximum Operating Force (gms.)	Maximum Pre-Travel inches (mm)	Operating Point inches (mm)	Minimum Over-Travel inches (mm)	Max. Movement Differential inches (mm)	Max. Rest Position inches (mm)	Actuation Length inches (mm)
<i>Auxiliary actuator, front-mounted (FM)</i>								
 MB	DB5	12	0.354 (9.0)	0.472±0.098 (12.0±2.5)	0.138 (3.5)	0.047 (1.2)	0.709 (18.0)	0.276 (7.0)
	DB1/3	25	0.354 (9.0)	0.472±0.098 (12.0±2.5)	0.138 (3.5)	0.047 (1.2)	0.709 (18.0)	0.276 (7.0)
	DB6	25	0.354 (9.0)	0.472±0.098 (12.0±2.5)	0.138 (3.5)	0.071 (1.8)	0.709 (18.0)	0.276 (7.0)
	DB2	40	0.354 (9.0)	0.472±0.118 (12.0±3.0)	0.138 (3.5)	0.059 (1.5)	0.709 (18.0)	0.276 (7.0)
	DB7	45	0.354 (9.0)	0.472±0.118 (12.0±3.0)	0.138 (3.5)	0.071 (1.8)	0.709 (18.0)	0.276 (7.0)
 MC	DB5	10	0.394 (10.0)	0.492±0.118 (12.5±3.0)	0.157 (4.0)	0.055 (1.4)	0.787 (20.0)	0.370 (9.4)
	DB1/3	22	0.394 (10.0)	0.492±0.118 (12.5±3.0)	0.157 (4.0)	0.055 (1.4)	0.787 (20.0)	0.370 (9.4)
	DB6	22	0.394 (10.0)	0.492±0.118 (12.5±3.0)	0.157 (4.0)	0.083 (2.1)	0.787 (20.0)	0.370 (9.4)
	DB2	35	0.394 (10.0)	0.492±0.138 (12.5±3.5)	0.157 (4.0)	0.071 (1.8)	0.787 (20.0)	0.370 (9.4)
	DB7	40	0.394 (10.0)	0.492±0.138 (12.5±3.5)	0.157 (4.0)	0.083 (2.1)	0.787 (20.0)	0.370 (9.4)
 MD	DB5	4	1.063 (27.0)	0.709±0.315 (18.0±8.0)	0.394 (10.0)	0.236 (6.0)	1.575 (40.0)	1.713 (43.5)
	DB1/3	9	1.063 (27.0)	0.709±0.315 (18.0±8.0)	0.394 (10.0)	0.236 (6.0)	1.575 (40.0)	1.713 (43.5)
	DB6	9	1.063 (27.0)	0.709±0.315 (18.0±8.0)	0.394 (10.0)	0.354 (9.0)	1.575 (40.0)	1.713 (43.5)
	DB2/7	—	—	—	—	—	—	<i>on request</i>
 UB	DB5	14	0.354 (9.0)	0.677±0.098 (17.2±2.5)	0.138 (3.5)	0.047 (1.2)	0.866 (22.0)	0.185 (4.7)
	DB1/3	30	0.354 (9.0)	0.677±0.098 (17.2±2.5)	0.138 (3.5)	0.047 (1.2)	0.866 (22.0)	0.185 (4.7)
	DB6	30	0.354 (9.0)	0.677±0.098 (17.2±2.5)	0.138 (3.5)	0.071 (1.8)	0.866 (22.0)	0.185 (4.7)
	DB2	50	0.354 (9.0)	0.677±0.118 (17.2±3.0)	0.138 (3.5)	0.059 (1.5)	0.866 (22.0)	0.185 (4.7)
	DB7	56	0.354 (9.0)	0.677±0.118 (17.2±3.0)	0.138 (3.5)	0.071 (1.8)	0.866 (22.0)	0.185 (4.7)
 UC	DB5	12	0.394 (10.0)	0.697±0.118 (17.7±3.0)	0.157 (4.0)	0.055 (1.4)	0.945 (24.0)	0.280 (7.1)
	DB1/3	25	0.394 (10.0)	0.697±0.118 (17.7±3.0)	0.157 (4.0)	0.055 (1.4)	0.945 (24.0)	0.280 (7.1)
	DB6	25	0.394 (10.0)	0.697±0.118 (17.7±3.0)	0.157 (4.0)	0.083 (2.1)	0.945 (24.0)	0.280 (7.1)
	DB2	40	0.394 (10.0)	0.697±0.138 (17.7±3.5)	0.157 (4.0)	0.071 (1.8)	0.945 (24.0)	0.280 (7.1)
	DB7	45	0.394 (10.0)	0.697±0.138 (17.7±3.5)	0.157 (4.0)	0.083 (2.1)	0.945 (24.0)	0.280 (7.1)
 UD	DB5	4	1.063 (27.0)	0.913±0.315 (23.2±8.0)	0.394 (10.0)	0.236 (6.0)	1.732 (44.0)	1.622 (41.2)
	DB1/3	9	1.063 (27.0)	0.913±0.315 (23.2±8.0)	0.394 (10.0)	0.236 (6.0)	1.732 (44.0)	1.622 (41.2)
	DB6	9	1.063 (27.0)	0.913±0.315 (23.2±8.0)	0.394 (10.0)	0.354 (9.0)	1.732 (44.0)	1.622 (41.2)
	DB2/7	—	—	—	—	—	—	<i>on request</i>
 TB	DB5	14	0.354 (9.0)	0.669±0.098 (17.0±2.5)	0.138 (3.5)	0.047 (1.2)	0.866 (22.0)	0.185 (4.7)
	DB1/3	30	0.354 (9.0)	0.669±0.098 (17.0±2.5)	0.138 (3.5)	0.047 (1.2)	0.866 (22.0)	0.185 (4.7)
	DB6	30	0.354 (9.0)	0.669±0.098 (17.0±2.5)	0.138 (3.5)	0.071 (1.8)	0.866 (22.0)	0.185 (4.7)
	DB2	50	0.354 (9.0)	0.669±0.118 (17.0±3.0)	0.138 (3.5)	0.059 (1.5)	0.866 (22.0)	0.185 (4.7)
	DB7	56	0.354 (9.0)	0.669±0.118 (17.0±3.0)	0.138 (3.5)	0.071 (1.8)	0.866 (22.0)	0.185 (4.7)
 TC	DB5	12	0.394 (10.0)	0.689±0.118 (17.5±3.0)	0.157 (4.0)	0.055 (1.4)	0.945 (24.0)	0.280 (7.1)
	DB1/3	25	0.394 (10.0)	0.689±0.118 (17.5±3.0)	0.157 (4.0)	0.055 (1.4)	0.945 (24.0)	0.280 (7.1)
	DB6	25	0.394 (10.0)	0.689±0.118 (17.5±3.0)	0.157 (4.0)	0.083 (2.1)	0.945 (24.0)	0.280 (7.1)
	DB2	40	0.394 (10.0)	0.689±0.138 (17.5±3.5)	0.157 (4.0)	0.071 (1.8)	0.945 (24.0)	0.280 (7.1)
	DB7	45	0.394 (10.0)	0.689±0.138 (17.5±3.5)	0.157 (4.0)	0.083 (2.1)	0.945 (24.0)	0.280 (7.1)
 TD	DB5	4	1.063 (27.0)	0.906±0.315 (23.0±8.0)	0.394 (10.0)	0.236 (6.0)	1.732 (44.0)	1.622 (41.2)
	DB1/3	9	1.063 (27.0)	0.906±0.315 (23.0±8.0)	0.394 (10.0)	0.236 (6.0)	1.732 (44.0)	1.622 (41.2)
	DB6	9	1.063 (27.0)	0.906±0.315 (23.0±8.0)	0.394 (10.0)	0.354 (9.0)	1.732 (44.0)	1.622 (41.2)
	DB2/7	—	—	—	—	—	—	<i>on request</i>
 GB*	DB5	10	0.394 (10.0)	0.508±0.102 (12.9±2.6)	0.118 (3.0)	0.055 (1.4)	0.787 (20.0)	0.370 (9.4)
	DB1/3	21	0.394 (10.0)	0.508±0.102 (12.9±2.6)	0.118 (3.0)	0.055 (1.4)	0.787 (20.0)	0.370 (9.4)
	DB6	21	0.394 (10.0)	0.508±0.102 (12.9±2.6)	0.118 (3.0)	0.083 (2.1)	0.787 (20.0)	0.370 (9.4)
	DB2	36	0.394 (10.0)	0.508±0.102 (12.9±2.6)	0.118 (3.0)	0.055 (1.4)	0.787 (20.0)	0.370 (9.4)
	DB7	42	0.394 (10.0)	0.508±0.102 (12.9±2.6)	0.118 (3.0)	0.083 (2.1)	0.787 (20.0)	0.370 (9.4)
 GC*	DB5	7	0.512 (13.0)	0.571±0.142 (14.5±3.6)	0.157 (4.0)	0.071 (1.8)	0.945 (24.0)	0.638 (16.2)
	DB1/3	16	0.512 (13.0)	0.571±0.142 (14.5±3.6)	0.157 (4.0)	0.071 (1.8)	0.945 (24.0)	0.638 (16.2)
	DB6	16	0.512 (13.0)	0.571±0.142 (14.5±3.6)	0.157 (4.0)	0.083 (2.1)	0.945 (24.0)	0.638 (16.2)
	DB2	26	0.512 (13.0)	0.571±0.142 (14.5±3.6)	0.157 (4.0)	0.071 (1.8)	0.945 (24.0)	0.638 (16.2)
	DB7	30	0.512 (13.0)	0.571±0.142 (14.5±3.6)	0.157 (4.0)	0.094 (2.4)	0.945 (24.0)	0.638 (16.2)
 HB*	DB5	11	0.354 (9.0)	0.531±0.098 (13.5±2.5)	0.098 (2.5)	0.055 (1.4)	0.787 (20.0)	0.311 (7.9)
	DB1/3	23	0.354 (9.0)	0.531±0.098 (13.5±2.5)	0.098 (2.5)	0.055 (1.4)	0.787 (20.0)	0.311 (7.9)
	DB6	23	0.354 (9.0)	0.531±0.098 (13.5±2.5)	0.098 (2.5)	0.083 (2.1)	0.787 (20.0)	0.311 (7.9)
	DB2	29	0.354 (9.0)	0.531±0.098 (13.5±2.5)	0.098 (2.5)	0.055 (1.4)	0.787 (20.0)	0.311 (7.9)
	DB7	45	0.354 (9.0)	0.531±0.098 (13.5±2.5)	0.098 (2.5)	0.083 (2.1)	0.787 (20.0)	0.311 (7.9)
 OB*	DB5	11	0.354 (9.0)	0.693±0.098 (17.6±2.5)	0.079 (2.0)	0.055 (1.4)	0.906 (23.0)	0.287 (7.3)
	DB1/3	23	0.354 (9.0)	0.693±0.098 (17.6±2.5)	0.079 (2.0)	0.055 (1.4)	0.906 (23.0)	0.287 (7.3)
	DB6	23	0.354 (9.0)	0.693±0.098 (17.6±2.5)	0.079 (2.0)	0.083 (2.1)	0.906 (23.0)	0.287 (7.3)
	DB2	39	0.354 (9.0)	0.693±0.098 (17.6±2.5)	0.079 (2.0)	0.055 (1.4)	0.906 (23.0)	0.287 (7.3)
	DB7	45	0.354 (9.0)	0.693±0.098 (17.6±2.5)	0.079 (2.0)	0.083 (2.1)	0.906 (23.0)	0.287 (7.3)

*For 85°C only

Ordering Information

DB			B		B1		AA		
Series/Prefix			Code	Contact Configuration	Code	Terminal Type inches (mm)	Code	Actuator Type*	
Code	UL Rating 1054	EN 61058 Rating	+120°C Operating Temp			B1	0.110 x 0.020 (2.8 x 0.5) QC, Straight	AA	Spherical-head w/o Auxiliary Actuator
1	5A, 125/250VAC	6A, 250V~	A	SPST NO	A1	Solder, Short	BA	Radius w/o Auxiliary Actuator	
2	10.1A, 125/250VAC 1/4HP, 125VAC	10(1.5)A, 250V~	B	SPST NC	C1	0.051 x 0.020 (1.3 x 0.5) PCB, Straight	*For further actuators see Actuation Specifications table.		
3	0.1A, 125/250VAC	0.1A, 250V	C	SPDT	D1	0.024 x 0.020 (0.6 x 0.5) PCB, Straight			
5*	1A, 125/250VAC	1A, 250V	+85°C Operating Temp*			D2			0.024 x 0.020 (0.6 x 0.5) PCB, RH Side with Location Pins
6*	5A, 125/250VAC	6A, 250V	E	SPST NO	D3	0.024 x 0.020 (0.6 x 0.5) PCB, LH Side with Location Pins			
7*	10.1A, 125/250VAC 1/4 HP, 125VAC	10 (1.5)A, 250V~	F	SPST NC	D4	0.024 x 0.020 (0.6 x 0.5) PCB, RH Side			
			G	SPDT	D5	0.024 x 0.020 (0.6 x 0.5) PCB, LH Side			

*85°C versions use plastic levers

*85°C only

Specifications subject to change without notice.



Компания «ЭлектроПласт» предлагает заключение долгосрочных отношений при поставках импортных электронных компонентов на взаимовыгодных условиях!

Наши преимущества:

- Оперативные поставки широкого спектра электронных компонентов отечественного и импортного производства напрямую от производителей и с крупнейших мировых складов;
- Поставка более 17-ти миллионов наименований электронных компонентов;
- Поставка сложных, дефицитных, либо снятых с производства позиций;
- Оперативные сроки поставки под заказ (от 5 рабочих дней);
- Экспресс доставка в любую точку России;
- Техническая поддержка проекта, помощь в подборе аналогов, поставка прототипов;
- Система менеджмента качества сертифицирована по Международному стандарту ISO 9001;
- Лицензия ФСБ на осуществление работ с использованием сведений, составляющих государственную тайну;
- Поставка специализированных компонентов (Xilinx, Altera, Analog Devices, Intersil, Interpoint, Microsemi, Aeroflex, Peregrine, Syfer, Eurofarad, Texas Instrument, Miteq, Cobham, E2V, MA-COM, Hittite, Mini-Circuits, General Dynamics и др.);

Помимо этого, одним из направлений компании «ЭлектроПласт» является направление «Источники питания». Мы предлагаем Вам помощь Конструкторского отдела:

- Подбор оптимального решения, техническое обоснование при выборе компонента;
- Подбор аналогов;
- Консультации по применению компонента;
- Поставка образцов и прототипов;
- Техническая поддержка проекта;
- Защита от снятия компонента с производства.



Как с нами связаться

Телефон: 8 (812) 309 58 32 (многоканальный)

Факс: 8 (812) 320-02-42

Электронная почта: org@eplast1.ru

Адрес: 198099, г. Санкт-Петербург, ул. Калинина, дом 2, корпус 4, литера А.