

3M

Scotch-Weld™ Hot Melt Applicator PG II LT Owner's Manual

Aplicador por fusión al calor de Scotch-Weld™ PG II LT de 3M™ Manual del usuario

Manuel de l'utilisateur – Applicateur d'adhésif thermo-fusible PG II LT 3M™ Scotch-Weld™

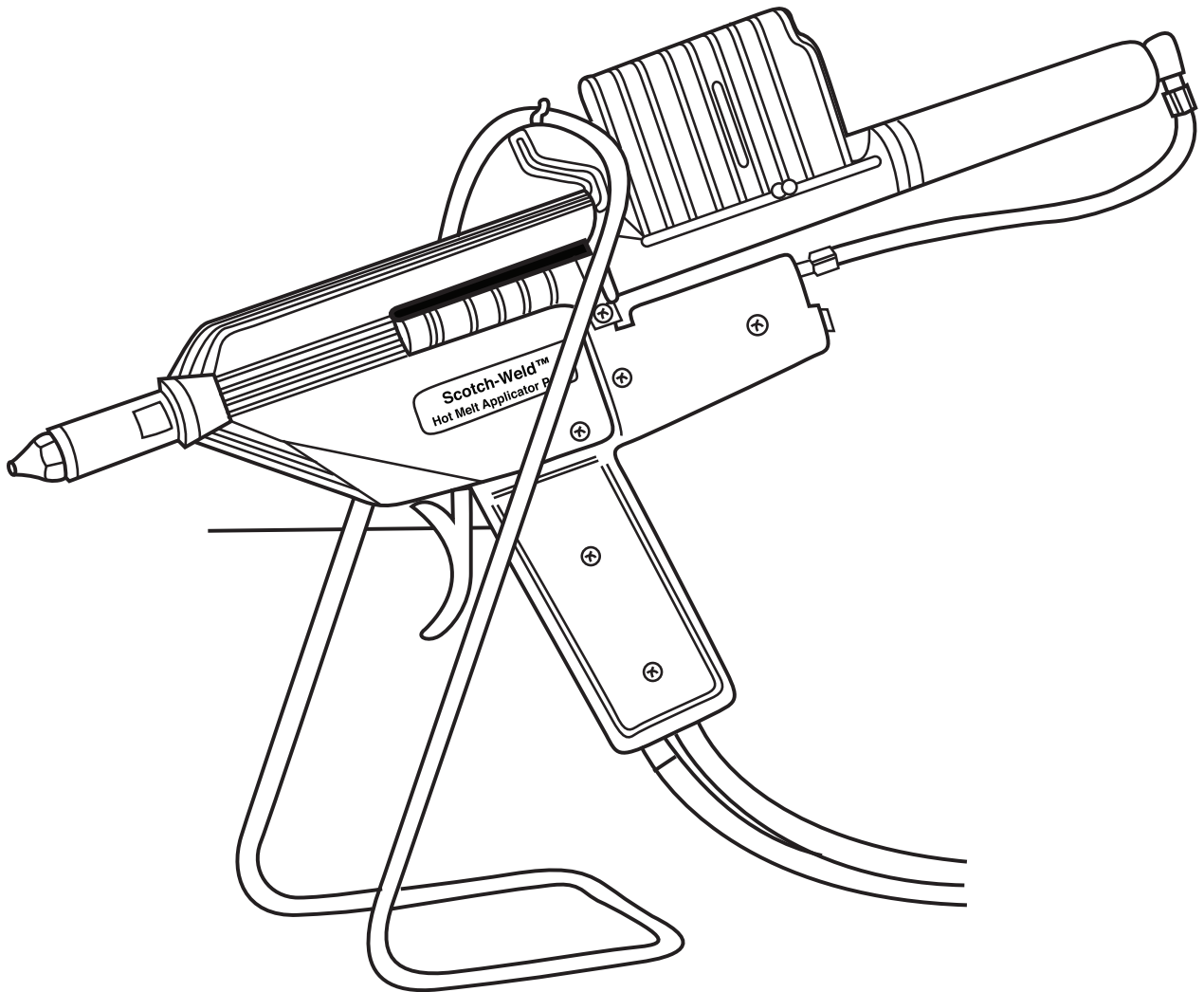

Use only with 3M™ Scotch-Weld™ Hot Melt LM Adhesives

Úselo sólomente con adhesivos de fusión al calor Scotch-Weld™ LM de 3M™

À utiliser uniquement avec les adhésifs thermo-fusibles LM 3M™ Scotch-Weld™

General Information

- Important Safety Instructions.....1
- General Information.....2
- Set Up and Installation.....3
- Operation.....5
- Preventive Maintenance7
- Troubleshooting9
 - Repair Part Kits11
- Repair Procedures13
- General Assembly (Schematic).....20
- Electrical Control/Wiring Arrangement.....21
- Flow Control22
- Accessories.....23
- Repair Service24
- Important Notice24
- Warranty and Limitation of Remedies.....24
- Limitation of Liability.....24
- 3M Sales Branches.....Back Cover

Important Safety Instructions

SAVE THESE INSTRUCTIONS

Read instructions thoroughly before operating or performing any maintenance on 3M™ Scotch-Weld™ Hot Melt Applicator PG II LT.

Danger

Do not modify the plug provided with the 3M Scotch-Weld Hot Melt Applicator PG II LT. Improper grounding connection of the plug may cause electrical shock. Check with a qualified electrician or service person to determine whether the plug is properly grounded.

Caution

Use only an approved extension cord with 3M Scotch-Weld Hot Melt Applicator PG II LT. Use of improper extension cord may cause electrical shock. Use an extension cord that complies with NEC requirements and state and local electrical requirements.

Caution

Disconnect air and electrical power and make sure applicator is at room temperature before servicing 3M Scotch-Weld Hot Melt Applicator PG II LT. Failure to disconnect air and electrical power before servicing may cause electrical shock or damage to the applicator.

Caution

Contact with molten adhesive or hot applicator tip or metal components may cause burns. Wear heat-resistant gloves and safety glasses when operating or repairing the 3M Scotch-Weld Hot Melt Applicator PG II LT.

Important

Do not connect 3M Scotch-Weld Hot Melt Applicator PG II LT to air supply with air pressure greater than 80 psi. Damage to the applicator may result.

Important

Use 3M™ Scotch-Weld™ Hot Melt LM Adhesives only. Use of other adhesives may damage the applicator or result in hazardous conditions.

READ INSTRUCTIONS THOROUGHLY BEFORE OPERATING OR PERFORMING ANY MAINTENANCE ON 3M™ SCOTCH-WELD™ HOT MELT APPLICATOR PG II LT.

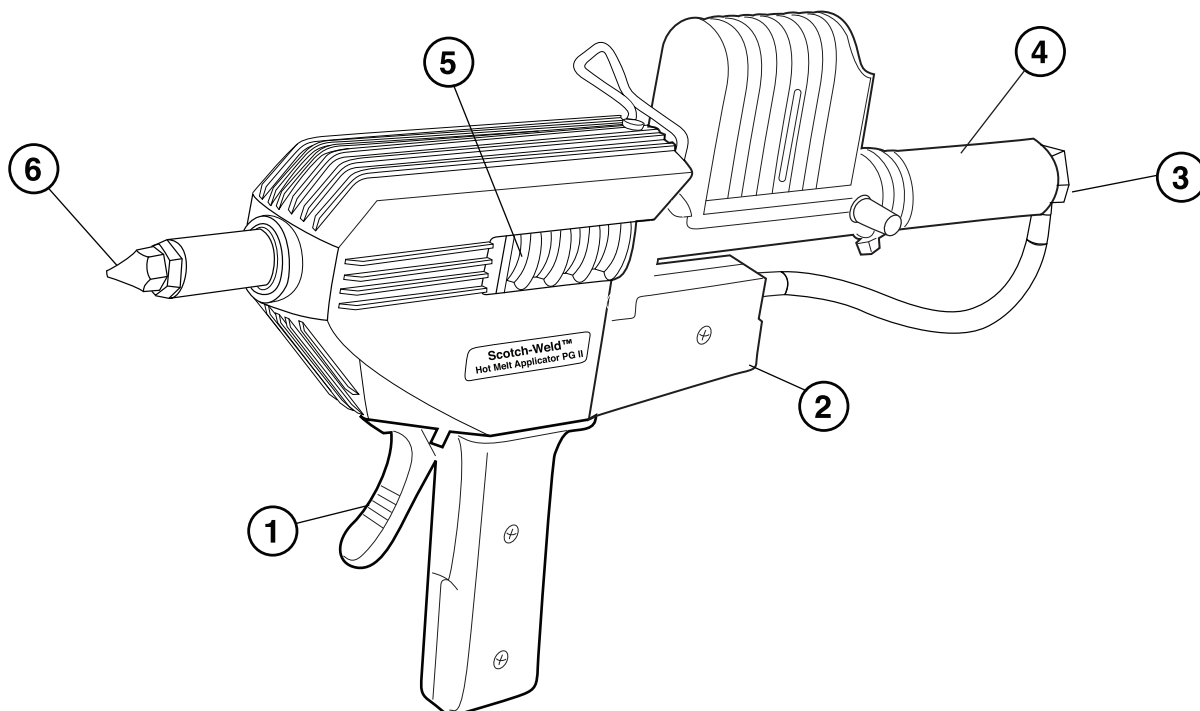

The 3M™ Scotch-Weld™ Hot Melt Applicator PG II LT is designed to be a simple, reliable tool for dispensing 3M™ Scotch-Weld™ Hot Melt LM Adhesive Sticks.

⚠ Important

Use 3M Scotch-Weld Hot Melt LM Adhesives only. Use of other adhesives may damage the applicator or result in hazardous conditions.

It is self-contained and hand held, designed for multi-station or intermittent manual adhesive application.

The 3M Scotch-Weld Hot Melt Applicator PG II LT uses electric heat to melt the adhesive, and air pressure to deliver the adhesive. Adhesive temperature is automatically maintained by a fixed thermostat on the heat block. The system is further protected by a thermal cutout (TCO), which acts as a thermal fuse.

Please take time to properly fill out and return your 3M Scotch-Weld Hot Melt Applicator PG II LT Warranty Card.

When trigger (1) is pulled, the variable regulator (2) allows air pressure into rear of the Speedloader stick feed (3). Air pushes the piston (4), which advances adhesive stick through applicator. As adhesive advances, it passes through hard plastic insulating sleeve (5) which acts as thermal barrier to keep molten adhesive and heat in forward portion of the applicator. The rest of the applicator stays cool.

As adhesive advances into the heat block, it is melted and liquefied. With pressure from the solid adhesive sticks and the piston, the liquid adhesive is forced out of the applicator through the nozzle tip (6). When the trigger is released, air pressure is released from the rear of the loading chamber. Pressure on the molten adhesive in the front of the applicator is then also relieved. Spring tension in the nozzle valve retracts the valve, neatly cutting off the adhesive flow.

The delivery rate of molten adhesive for the 3M Scotch-Weld Hot Melt Applicator PG II LT is approximately six pounds per hour with 3M™ Scotch-Weld™ Hot Melt Adhesive 3762-LM utilizing the standard tip 9921. Adhesive flow rates will vary with the different 3M adhesives in the line and the nozzle tip you choose.

Setup and Installation

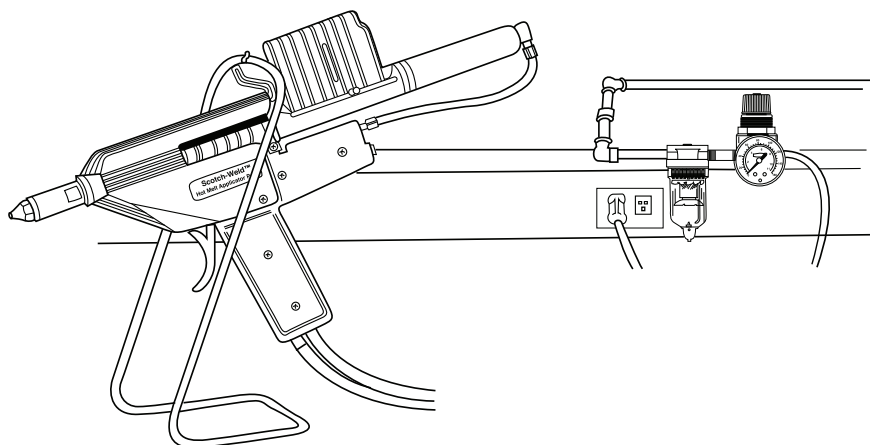

1. Remove the 3M™ Scotch-Weld™ Hot Melt Applicator PG II LT from its shipper and inspect for obvious damage.

2. Connect Air and Electrical Service

Select a work station where 120 VAC grounded receptacle and compressed air service are available.

Grounding Instructions

The 3M Scotch-Weld Hot Melt Applicator PG II LT must be grounded. If it should malfunction or break down, grounding provides a path of least resistance for electric current to help reduce the risk of electrical shock. This applicator is equipped with a cord having an equipment-grounding conductor and grounding plug. This plug must be used with appropriate outlets that are properly installed and grounded in accordance with all local codes and ordinances.

The 3M Scotch-Weld Hot Melt Applicator PG II LT is designed for use on a nominal 120-volt circuit and has a grounding plug as shown in illustration above. Make sure the applicator is connected to an outlet having the same configuration as the plug. No adaptor should be used.

⚠ Danger

Do not modify the plug provided with the 3M Scotch-Weld Hot Melt Applicator PG II LT. Improper grounding connection of the plug may cause electrical shock. Check with a qualified electrician or service person to determine whether the plug is properly grounded.

Electrical outlet should be as close to air supply as possible. **Filtered air regulated to 80 psi maximum is vital to optimum operation.**

⚠ Important

Do not connect 3M Scotch-Weld Hot Melt Applicator PG II LT to air supply with air pressure greater than 80 psi. Damage to the applicator may result.

Refer to step 3 on page 4 for air filter and regulator installation procedure.

Connect air hose using two 1/2" open-end wrenches. Remove the steel swivel portion of the connector and insert the steel swivel into 1/8" female pipe thread air source. Insert and tighten the brass fitting into the swivel and snug up all fittings.

Setup and Installation

3. Install Air Filter and Regulator

An air filter and moisture trap must be installed at the applicator connection point of the air system. Install an air filter WATTS #602-2S Model M4 or equivalent at the air outlet or as close as possible to it. The hose connection at the end of the 3M™ Scotch-Weld™ Hot Melt Applicator PG II LT air hose is 1/8" standard male pipe fitting.

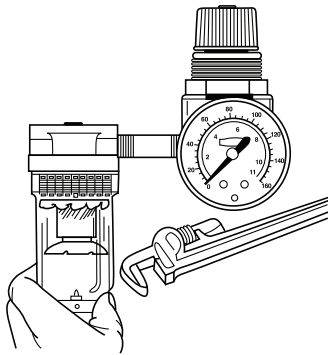

4. Install Bench Stand

Prior to start up in operation, set the bench stand on work surface so that tip of the applicator points away from work area when applicator is not in use. When bench stand is in most desirable position, fasten permanently using the screws provided. (If portability of the bench stand is desired, simply attach the stand to a piece of scrap wood approximately 7" x 16" using either screws or by adhering the stand to the wood.)

Operation

Warm Up

Set the off/on switch to the “on” position and set the 3M™ Scotch-Weld™ Hot Melt Applicator PG II LT in the bench stand for approximately 15 minutes. During this warm-up period you may note a slight dripping from the nozzle tip. This dripping is due to expansion of the adhesive during warm-up.

Caution

Contact with molten adhesive or hot applicator tip or metal components may cause burns. Wear heat-resistant gloves and safety glasses when operating or repairing the 3M Scotch-Weld Hot Melt Applicator PG II LT.

Loading

Important

Use 3M™ Scotch-Weld™ Hot Melt LM Adhesives only. Use of other adhesives may damage the applicator or result in hazardous conditions.

After warm-up, load applicator with the 3M Scotch-Weld Hot Melt LM Adhesive you'll be using on the job.

To do this, fully retract the Speedloader piston by pulling one of the retract knobs located on either side of the loading chamber. Insert up to three 3M Scotch-Weld Hot Melt LM Adhesive Sticks into the chamber through the rear loading port. The applicator is now ready for operation.

Note

Do not depress trigger on the applicator unless there is adhesive in the loading chamber. Damage to the applicator may result.

As adhesive is extruded, the piston will move forward. This will be visually evident by the forward movement of the retract knobs. As the piston approaches the front of the chamber, a whistling sound will be heard. At this point the piston may be retracted and another adhesive stick will fall into place. The applicator is again ready for operation. Adhesive may be loaded into the chamber via the rear port at any time during operation thus saving time and increasing productivity.

If it is desired to remove adhesive once it is in the loading chamber, simply roll the applicator to one side and then point up. This will allow the adhesive to roll up and out of the chamber.

In order to keep the Speedloader stick feed operating at maximum efficiency, the chamber should be sprayed inside while the piston is in the full forward position with 3M™ Silicone Lubricant or equivalent once a week.

Application

Get a feel for your new 3M Scotch-Weld Hot Melt Applicator PG II LT. Start by applying small amounts of adhesive in puddles on a piece of scrap or paper. Try feathering the trigger. The 3M Scotch-Weld Hot Melt Applicator PG II is unique in this respect. Pull the trigger back slowly and note a small discharge of adhesive; pull the trigger back more and note increasing adhesive flow. When the trigger is fully depressed; you will get maximum flow. If more or less flow is desired, refer to page 22 of this manual.

Note

Do not operate the applicator without a nozzle tip. Damage to the applicator may result.

Changing Tips

Caution

Contact with molten adhesive or hot applicator tip or metal components may cause burns. Wear heat-resistant gloves and safety glasses when operating or repairing the 3M™ Scotch-Weld™ Hot Melt Applicator PG II LT.

The 3M Scotch-Weld Hot Melt Applicator PG II LT includes a 9921 (.093") tip as standard equipment. Other tips, available from your 3M Scotch-Weld Hot Melt Adhesive distributor, are shown on page 22 of this manual.

Note

Disconnect air supply before changing tips.

Tips can be changed only when the applicator is hot. You will need a 5/8" and a 1/2" open-end wrench. Hold the nozzle valve hex firmly with the 5/8" wrench, while removing the nozzle tip with the 1/2" wrench. The accessory tip is mounted using the reverse procedure. Snug the tip lightly.

Note

Do not tighten the tip. Overtightening could damage the valve assembly.

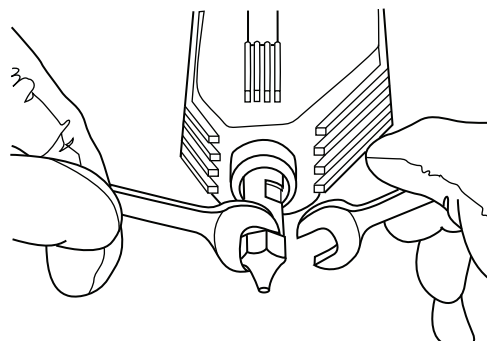

Preventive Maintenance

Before Operation

1. Make sure **filtered** compressed air is available, regulated to a maximum of 80 psi or to a minimum of 40 psi. **DO NOT OPERATE 3M™ SCOTCH-WELD™ HOT MELT APPLICATOR PG II LT BELOW 40 PSI.** If low flow is experienced at 40 psi see page 9, Troubleshooting.

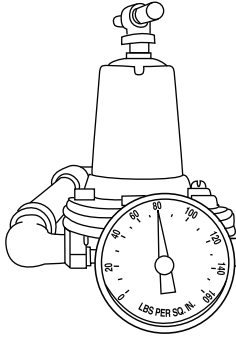

2. Make sure that the 3M Scotch-Weld Hot Melt Applicator PG II LT is plugged into 120 VAC and that the switch is in the “on” position.

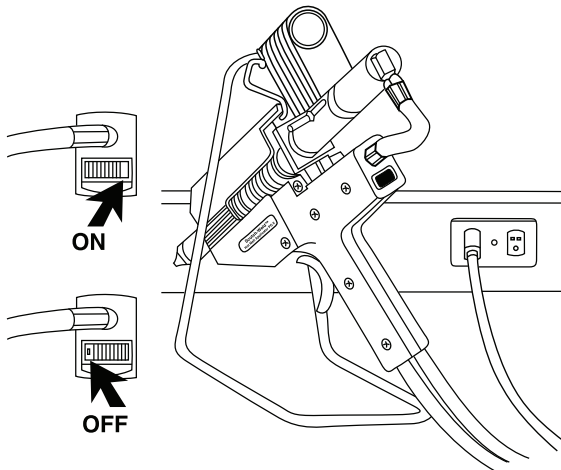

3. Inspect nozzle tip daily. Make sure tip is clean and clear of foreign matter. Using a coarse cloth, wipe off any accumulated adhesive or other foreign matter on the tip.



⚠ Caution

Contact with molten adhesive or hot applicator tip or metal components may cause burns. Wear heat-resistant gloves and safety glasses when operating or repairing the 3M Scotch-Weld Hot Melt Applicator PG II LT.

4. Be sure there is adhesive in the loading chamber.
5. Under normal conditions, allow at least 15 minutes for the applicator to warm up.

Note

If proper shutdown procedure has not been followed (see Preventive Maintenance, "After Operation," page 8), up to one hour heat up prior to use may be required.

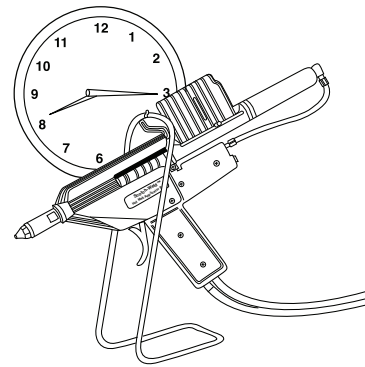

6. Under normal operations the in-line air filter should be removed and cleaned every six months (some air systems may require more periodic changing). Simply remove the filter from the air supply line and blow compressed air through the filter in reverse of normal air flow to remove particular matter.
7. Periodically inspect the applicator to ensure that assembly is proper (i.e. watch for loose screws, worn pins, etc). See page 9 through 19 for Troubleshooting and Repair Procedures.

During Operation

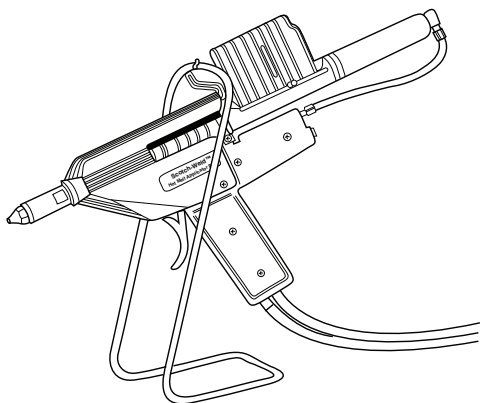

Always use the bench stand provided when 3M™ Scotch-Weld™ Hot Melt Applicator PG II LT is not in use. Do not lay the applicator on its side. This impedes cooling process and may cause plugging problems.

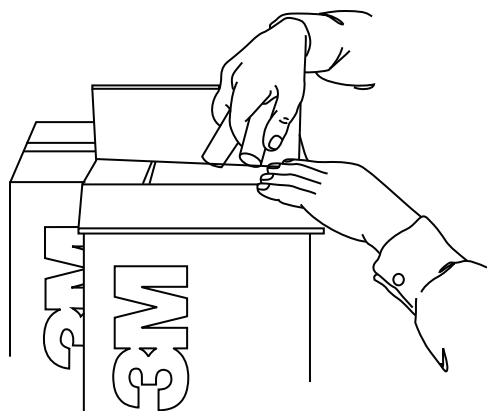

Open adhesive cartridge stick only when necessary. Keep sticks clean and free from airborne contaminants.

After Operation

Before shutting down the 3M Scotch-Weld Hot Melt Applicator PG II LT, put the electrical switch in the “off” position. Continue using the applicator until approximately one adhesive stick has been discharged.

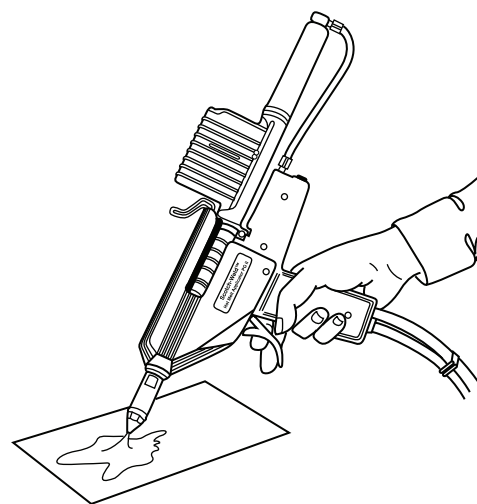

Note

If proper shutdown procedure has not been followed, up to one hour heat up prior to use may be required.



Lubricate inside loading chamber with 3M™ Silicone Lubricant or equivalent once a week.

Troubleshooting

Problem	Probable Cause (In order of priority)	Correction
Low or no adhesive flow	1. Hung adhesive stick	<p>Turn on the 3M™ Scotch-Weld™ Hot Melt Applicator PG II LT and allow it to heat for at least 60 minutes.</p> <div data-bbox="1046 365 1506 678" style="border: 1px solid black; padding: 5px;"> <p style="text-align: center;"> Caution</p> <p>Contact with molten adhesive or hot applicator tip or metal components may cause burns. Wear heat-resistant gloves and safety glasses when operating or repairing the 3M Scotch-Weld Hot Melt Applicator PG II LT.</p> </div> <p>With incoming air at 80 psi extrude adhesive. If unsuccessful remove nozzle assembly and extrude one stick of adhesive. Readjust incoming air to desired pressure.</p>
	2. Low air pressure	<p>Check to see if there is sufficient air pressure. Test by setting pressure at 80 psi. Check in-line filter to ensure that it is not plugged with contaminants. Disconnect in-line filter from air hose. Using a compressed air line, blow compressed air through the filter in the reverse flow position. If this does not increase air flow through the filter, swivel filter should be replaced.</p>
	3. No electricity	<p>Check to see that electrical service is live, and that lighted switch is in “on” position.</p>
	4. Dirty nozzle valve assembly	<p>Remove nozzle valve and clean. Run one adhesive stick out. Replace cleaned valve assembly. This step should only be done while tip is hot</p> <div data-bbox="1046 1521 1506 1834" style="border: 1px solid black; padding: 5px;"> <p style="text-align: center;"> Caution</p> <p>Contact with molten adhesive or hot applicator tip or metal components may cause burns. Wear heat-resistant gloves and safety glasses when operating or repairing the 3M Scotch-Weld Hot Melt Applicator PG II LT.</p> </div>
	5. Regulator malfunction	<p>Squeeze trigger and try to pull retract knobs. If they can be pulled back easily, install new regulator kit.</p>

Troubleshooting

Problem	Probable Cause (In order of priority)	Correction
Low or no adhesive flow (cont.)	6. Burned out heater(s)	<p>With Volt/Ohm Meter, run electrical continuity check on each heater (see page 17 for repair procedure). If open circuit exists, install new heater kit.</p> <div style="border: 1px solid black; padding: 5px; margin: 10px 0;"> <p style="text-align: center;"> Caution</p> <p>Disconnect air and electrical power and make sure applicator is at room temperature before servicing 3M™ Scotch-Weld™ Hot Melt Applicator PG II LT. Failure to disconnect air and electrical power before servicing may cause electrical shock or damage to the applicator.</p> </div>
	7. Jammed adhesive sticks	<p>If the piston is retracted before reaching the point where the whistle is heard, a jam-up of the adhesive may occur. To free this, simply retract the piston fully and roll the applicator to one side so that the adhesive in the magazine will free itself. Now push the knobs forward until the adhesive stick still in the chamber is contacted by the piston. Roll the applicator back to its normal operating position and continue extruding adhesive until the whistle is heard or until the piston has traveled its full length as indicated by the orange retract knobs.</p>
No heat	1. Blown thermal cutoff	<p>Replace with new Thermostat/TCO kit. Refer to page 18, paragraph J.</p>
Dripping Nozzle	<p>1. Regulator malfunction</p> <p>2. Expanded adhesive stick</p> <p>3. Worn nozzle valve</p>	<p>With finger off of trigger, attempt to retract piston. If piston is very difficult to pull back, air regulator may not be shutting off entirely. Replace regulator.</p> <p>Extrude one adhesive stick.</p> <p>Replace with new nozzle valve assembly. Refer to page 14, paragraph C.</p>

Troubleshooting

Repair Parts Kit

For ease and convenience in repair, 3M™ Scotch-Weld™ Hot Melt Applicator PG II LT repair part kits are available from your authorized 3M Scotch-Weld Adhesive distributor. When ordering part kits, provide the name and number of the repair part kit.

Part kits can also be ordered directly from the nearest 3M Sales Branch listed on the back cover.

Kit #	Repair Part Kit	# of Items/Kit	Kit #	Repair Part Kit	# of Items/Kit	Kit #	Repair Part Kit	# of Items/Kit
9200	Trigger Kit		9221	Handle Kit		9224	Miscellaneous Parts Kit	
	a. Trigger Pin	1		a. Right Handle Sub-Assembly	1		a. Heat Shield Screw, Top	1
	b. Trigger Assembly	1		b. Left- Handle Sub-Assembly	1		b. Heat Shield Screw, Side	2
9932	Heat Shield Kit			c. Machine Screw	4		c. Heat Shield Screw	4
	a. Heat Shield	1		d. Machine Screw	3		d. Shim	2
9204	Regulator Kit		9219	Switch Kit			e. Electrical Connector Screw	9
	a. Regulator Assembly	1		a. Switch Sub-Assembly	1		f. Connector Strip	2
9220	Regulator Hose Sub-Assembly Kit		9220	Hose Kit, Main			g. Handle Screw	4
	a. Hose Assembly	1		a. Hose Sub-Assembly	1		h. Regulator Screw	3
9207	Power Cord Kit			b. Cable Ties	5		i. Ground Wire Screw	2
	a. Power Cord Assembly	1	9220	Hose Kit			j. Hinge Pin	3
	b. Cable Ties	5		a. Hose	1		k. Bail Screw	2
9931	Thermostat/TCO Kit			b. Elbow	1		l. Lock Washer for Bail	2
	a. Thermal Cutout Assembly	1		c. Swivel Filter	1		m. Bail	2
	b. Machine Screw Large	1	9222	Heater Kit		9226	Dump Valve	
	c. Machine Screw Small	2		a. 125 W Heater	4		a. Valve	1
	d. Thermostat Sub-Assembly	1		b. Machine Screw	8	9260	Speedloader Hose Assembly	
				c. Cable Tie	1		a. Hose Assembly	1
			9223	Valve Kit		9936	Scotch-Weld SL Magazine Extension Kit	
				a. Nozzle Tip	1		a. Magazine Extension	1
				b. Valve Assembly	1	9935	Speedloader Assembly	
							a. Speedloader	1
							b. Hose	1
							c. Pin	1
							d. Bail	1

Your 3M™ Scotch-Weld™ Hot Melt Applicator PG II LT has been engineered for durability and reliability. However, as with any electrical-mechanical device, parts will wear with use and require replacement for optimum performance. We have listed below certain part kits that you may want to have available in case the immediate need for

replacement arises. All part kits listed are available from your authorized 3M Scotch-Weld Hot Melt Adhesive distributor or from the nearest 3M Sales Branch location listed on the back cover of this manual. **Please note the serial number of your 3M Scotch-Weld Hot Melt Applicator PG II LT before ordering part kits.**

Kit Number	Name	No. of Scotch-Weld Hot Melt Applicators in Use			
		2-5	6-10	11-15	16-20
9200	Trigger Kit 62-9200-6921-8	0	0	1	1
9932	Heat Shield Kit 62-9783-9932-7	0	1	1	2
9204	Regulator Kit 62-9204-6922-8	1	1	2	2
9207	Power Cord Kit 62-9207-6947-8	0	0	0	1
9931	Thermostat/TCO Kit 62-9783-9931-9	1	2	2	3
9219	Switch Kit 62-9219-2798-4	0	0	1	1
9220	Hose Kit 62-9220-2797-4	0	0	0	1
9221	Handle Kit 62-9221-2651-1	0	0	0	1
9222	Heater Kit 62-9222-6930-3	0	0	1	1
9223	Valve Kit 62-9223-6930-1	1	2	3	4
9226	Dump Valve Kit 62-9226-6990-8	0	0	1	1
9260	S/L Hose Assem. Kit 62-9260-2945-5	0	0	1	1

Repair Procedures

Caution

Disconnect air and electrical power and make sure applicator is at room temperature before servicing 3M™ Scotch-Weld™ Hot Melt Applicator PG II LT. Failure to disconnect air and electrical power before servicing may cause electrical shock or damage to the applicator.

Procedure	Part Kit
A.	Handle Kit
B.	Regulator Kit
C.	Valve Kit
D.	Hose Kit
E.	Power Cord Kit
F.	Switch Kit
G.	Trigger Kit
H.	Heat Shield Kit
I.	Heater Kit
J.	Thermostat/TCO Kit
K.	Heat Block Kit

Handle Disassembly Instructions

A. Handle Kit

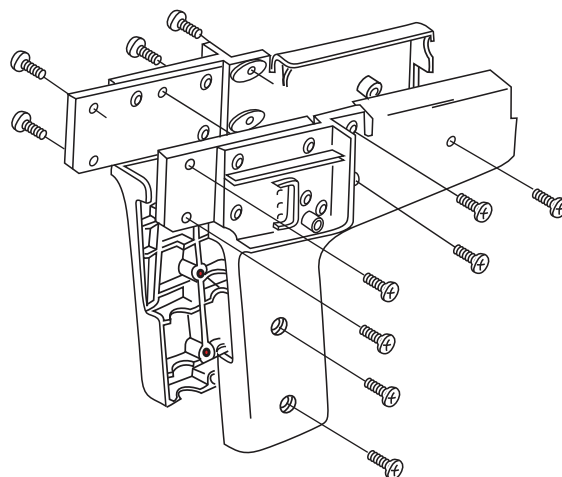

Remove heat shield (see procedure H, page 16). With the nozzle of the applicator pointing away from you, remove the seven Phillips head cap screws in the handle. These screws are located in the left hand side of the handle grip, two in the pistol grip itself, two just forward of the wire terminal and three to the rear of the wire terminal. Without removing the wires from the wire terminals, lift the handle up and to the front of the applicator. This operation will allow for subsequent repair steps.

To replace applicator handles, first follow “Handle Disassembly Instructions.” Next remove the electrical wiring from the terminal strip on the left handle, replacing them to the same terminals on the replacement. The right half of the handle is removed by removing the four Phillips head cap screws. Next remove the electrical wiring from the terminal strip and re-assemble these to the replacement right half handle. Lift the switch out of its slot in the handle and replace it in the new handle. Replace the trigger and trigger pin at this time. Using reverse procedure, reassemble the right handle half, then the left. Be sure all the electrical wires are in place and are not being pinched.

B. Regulator Kit

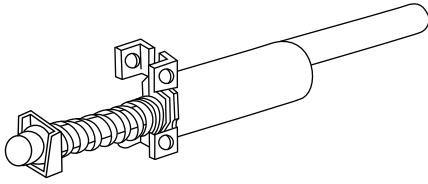

⚠ Caution

Disconnect air and electrical power and make sure applicator is at room temperature before servicing 3M™ Scotch-Weld™ Hot Melt Applicator PG II LT. Failure to disconnect air and electrical power before servicing may cause electrical shock or damage to the applicator.

First follow “Handle Disassembly Instructions,” Procedure A on page 13. Then remove the two large Phillips head screws to the rear of the wire terminals on the right hand side of the handle. This allows the regulator assembly to swing free, connected only by the hose going from the brass rear of the regulator to the loading chamber assembly, and then main hose assembly. Remove the main hose by unscrewing the elbow fitting from the regulator. Use a 5/16” wrench to remove the loading chamber hose from the regulator. Reassemble with a new regulator using reverse procedure. Be sure hose fittings are quite snug. Check for air leaks by activating the regulator. Once this is done, reassemble the handle and heat shield.

C. Valve Kit

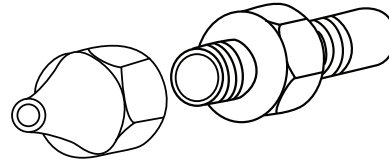

⚠ Caution

Contact with molten adhesive or hot applicator tip or metal components may cause burns. Wear heat-resistant gloves and safety glasses when operating or repairing the 3M Scotch-Weld Hot Melt Applicator PG II LT.

3M Scotch-Weld Hot Melt Applicator PG II LT must be warm prior to repairing nozzle valve.

Nozzle valve assembly consists of the nozzle tip and the nozzle valve. Remove the old valve assembly using a 5/8” open-end wrench. Replace with new assembly. Gently snug up the valve assembly. With a 1/2” wrench, also snug up the new tip.

D. Hose Kit

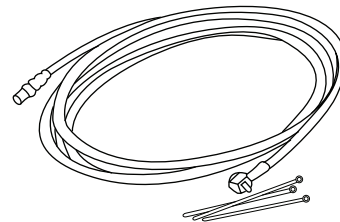

⚠ Caution

Disconnect air and electrical power and make sure applicator is at room temperature before servicing 3M Scotch-Weld Hot Melt Applicator PG II LT. Failure to disconnect air and electrical power before servicing may cause electrical shock or damage to the applicator.

Follow “Handle Disassembly Instructions,” Procedure A on page 13. Remove the main hose by unscrewing the elbow fitting from the air regulator. Cut the cable ties holding the power cord and hose assembly together. Remove the hose and reconnect the new hose using reverse procedure. Add new cable ties to the hose and power cord.

Repair Procedures

E. Power Cord Kit

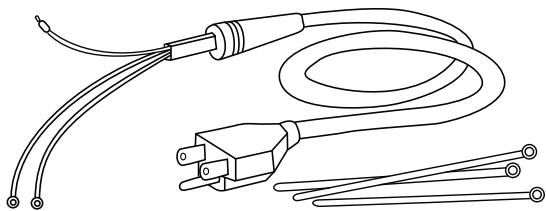

⚠ Caution

Disconnect air and electrical power and make sure applicator is at room temperature before servicing 3M™ Scotch-Weld™ Hot Melt Applicator PG II LT. Failure to disconnect air and electrical power before servicing may cause electrical shock or damage to the applicator.

Follow “Handle Disassembly Instructions,” Procedure A on page 13. The power cord wire from the switch is removed from the bayonet connector. The black and white wires are removed from their respective terminals. Remember which wire came off which terminal for reassembly. Consult the electrical wiring arrangement on page 21. Reassemble, following reverse procedure.

F. Switch Kit

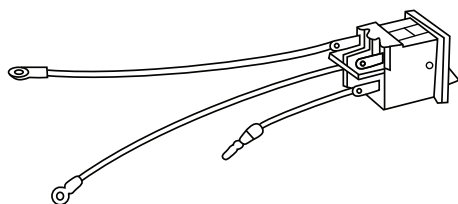

⚠ Caution

Disconnect air and electrical power and make sure applicator is at room temperature before servicing 3M Scotch-Weld Hot Melt Applicator PG II LT. Failure to disconnect air and electrical power before servicing may cause electrical shock or damage to the applicator.

Follow “Handle Disassembly Instructions,” Procedure A on page 13. Lift the switch from the slot in the right half of the handle. The power lead can be unplugged from the power cord receptacle. The other wires terminating in ring lugs should be removed from their respective terminals, noting that the black lead is connected to the Thermal Cut Out Assembly and the white lead to the heaters. Install the new switch using reverse procedure.

G. Trigger Kit

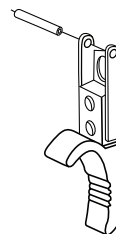

⚠ Caution

Disconnect air and electrical power and make sure applicator is at room temperature before servicing 3M Scotch-Weld Hot Melt Applicator PG II LT. Failure to disconnect air and electrical power before servicing may cause electrical shock or damage to the applicator.

Follow “Handle Disassembly Procedures,” Procedure A on page 13. Lift the trigger assembly off the trigger pin and replace. Reassemble, following reverse procedure.

Heat Shield Disassembly

H. Heat Shield Kit

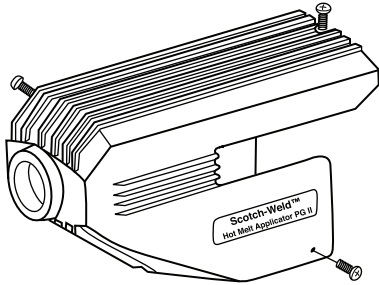

⚠ Caution

Disconnect air and electrical power and make sure applicator is at room temperature before servicing 3M™ Scotch-Weld™ Hot Melt Applicator PG II LT. Failure to disconnect air and electrical power before servicing may cause electrical shock or damage to the applicator.

Remove the heat shield assembly by removing the two Phillips head screws from either side of the heat shield and the one Phillips head screw on the heat shield immediately above the loading chamber. Reassemble, following reverse procedure.

I. Heater Kit

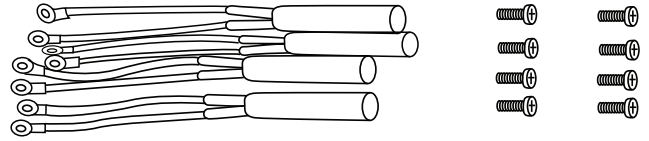

⚠ Caution

Disconnect air and electrical power and make sure applicator is at room temperature before servicing 3M Scotch-Weld Hot Melt Applicator PG II LT. Failure to disconnect air and electrical power before servicing may cause electrical shock or damage to the applicator.

Follow “Heat Shield Disassembly, “per procedure H. All heater wires must be disconnected from their respective terminal strips. With a suitable drift punch, drive the old heaters out through the top of the heat block.

All four heaters should be replaced making sure to reconnect the wires in the proper places. Refer to the “Wiring Arrangement” and “Electrical Control” diagrams, page 21. Be sure that heaters are bottomed out in the heat block. They should not stick out above the block more than 1/4”. It may be necessary to gently tap the heaters into place, but be careful not to crack the ceramic.

To ensure that heaters remain in place, gather all the wires together approximately 1/2” below the heat block and tightly attach the cable tie provided with the kit.

Repair Procedures

Heater Check-Out

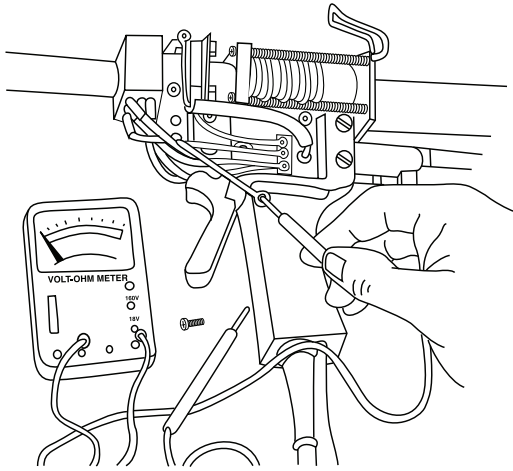

⚠ Caution

Disconnect air and electrical power and make sure applicator is at room temperature before servicing 3M™ Scotch-Weld™ Hot Melt Applicator PG II LT. Failure to disconnect air and electrical power before servicing may cause electrical shock or damage to the applicator.

Use Volt/Ohm Meter to check electrical continuity of each heater. If continuity exists, heater is okay. First remove heat shield. Heaters need not be removed from the block. Check in the following sequence: left front, right front, right rear, left rear. To start the check, remove only one wire from its connection on the terminal strip.

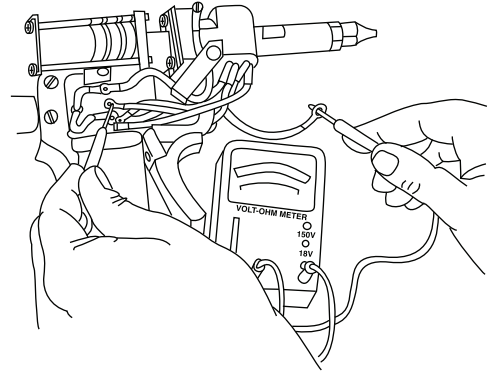

Place one probe from the meter on the connector of the wire that has been removed, and with the other probe, touch the matching connector on opposite side of the applicator. If needle on Volt/Ohm Meter swings, heater is okay.

Reconnect wire that was removed first, and continue sequence. If one or more heaters are burned out, refer to Repair Procedure, pages 13 through 19.

Repair Procedures

J. Thermostat/TCO Kit

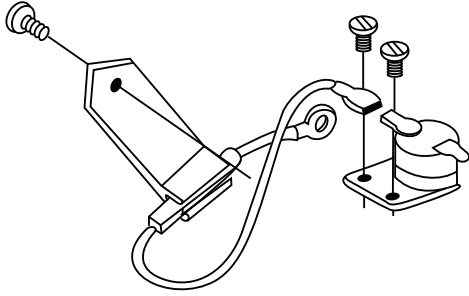

Caution

Disconnect air and electrical power and make sure applicator is at room temperature before servicing 3M™ Scotch-Weld™ Hot Melt Applicator PG II LT. Failure to disconnect air and electrical power before servicing may cause electrical shock or damage to the applicator.

Remove the heat shield assembly by removing the two Phillips head screws from either side of the heat shield and the one Phillips head screw on the heat shield immediately above the loading chamber.

The thermostat and TCO are assembled as a unit and are replaced as such no matter which component has failed.

The Quick-Slide clips should be removed from the thermostat. Remove the two screws holding the thermostat, and pry the thermostat from the block.

Insert new thermostat. **Make sure the rear rim of the thermostat is slipped into the slot in the heat block before affixing screws.**

The thermal cutout assembly is then removed by disconnecting the Phillips head screw, holding the thermal cutout to the head block on the stand off strip. Remove the other end of the thermal cutout from the terminal strip with a small Phillips screwdriver. Procedure is reversed to replace the thermal cutout.

Repair Procedures

K. Heat Block Kit

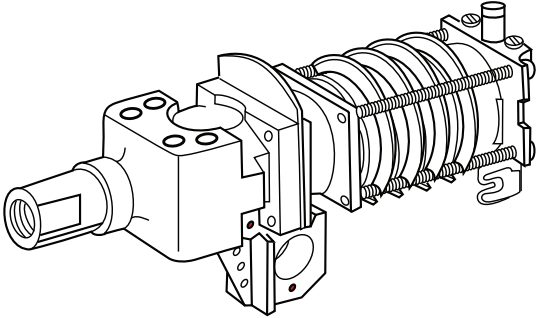

⚠ Caution

Disconnect air and electrical power and make sure applicator is at room temperature before servicing 3M™ Scotch-Weld™ Hot Melt Applicator PG II LT. Failure to disconnect air and electrical power before servicing may cause electrical shock or damage to the applicator.

If the original heat block is broken or needs replacement, you may use the 3M factory refurbish program. Please contact your distributor for information on our PG II LT equipment refurbish program.

General Assembly

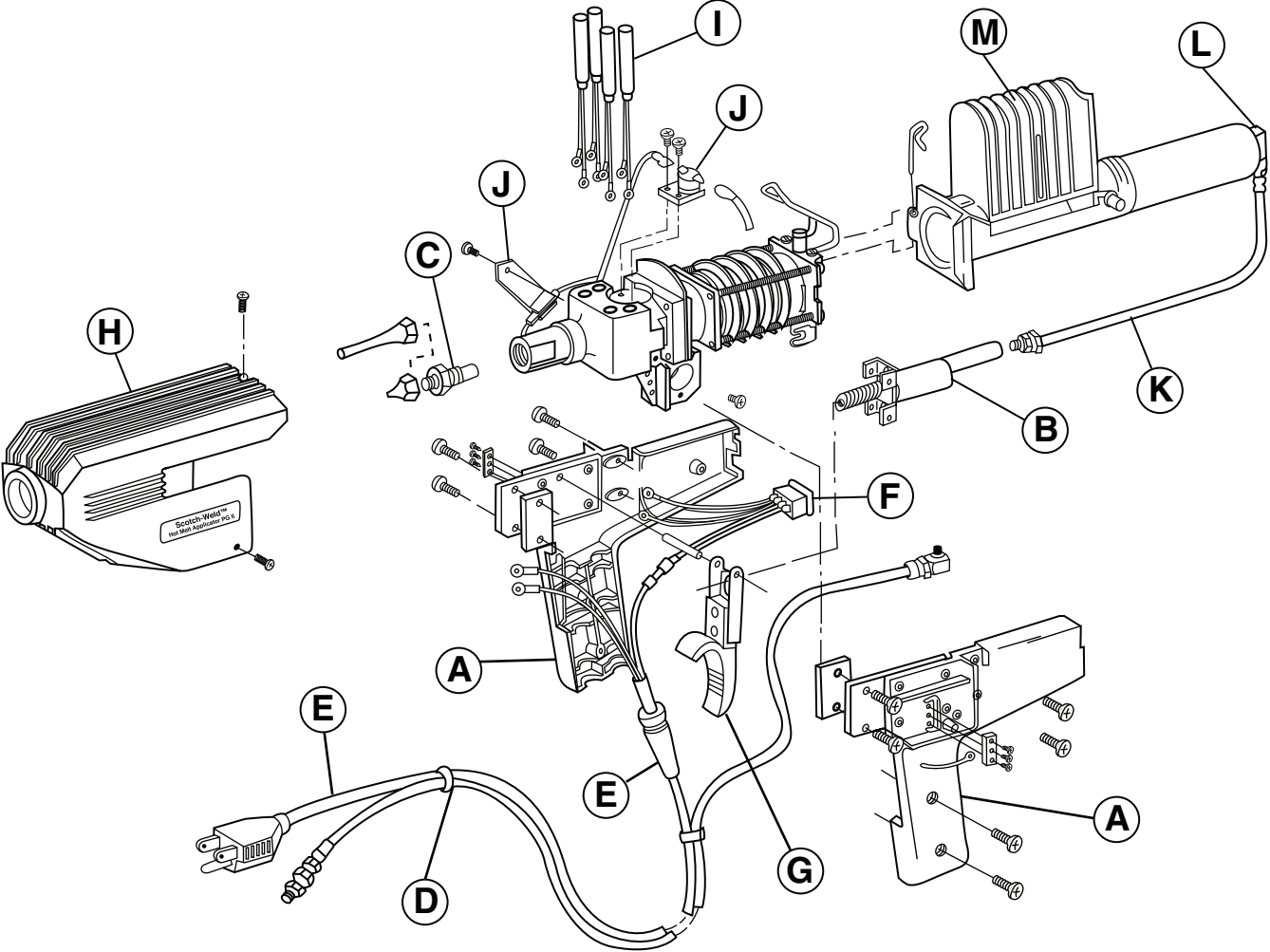

- A. 9221 Handle Kit
- B. 9204 Regulator Kit
- C. 9223 Valve Kit
- D. 9220 Hose Kit
- E. 9207 Power Cord Kit

- F. 9219 Switch Kit
- G. 9220 Trigger Kit
- H. 9932 Heat Shield Kit
- I. 9222 Heater Kit
- J. 9931 Thermostat/TCO Kit

- K. 9260 Speedloader Hose Assembly
- L. 9226 Dump Valve Kit
- M. 9935 Speedloader Chamber Assembly

General Assembly

Electrical Control

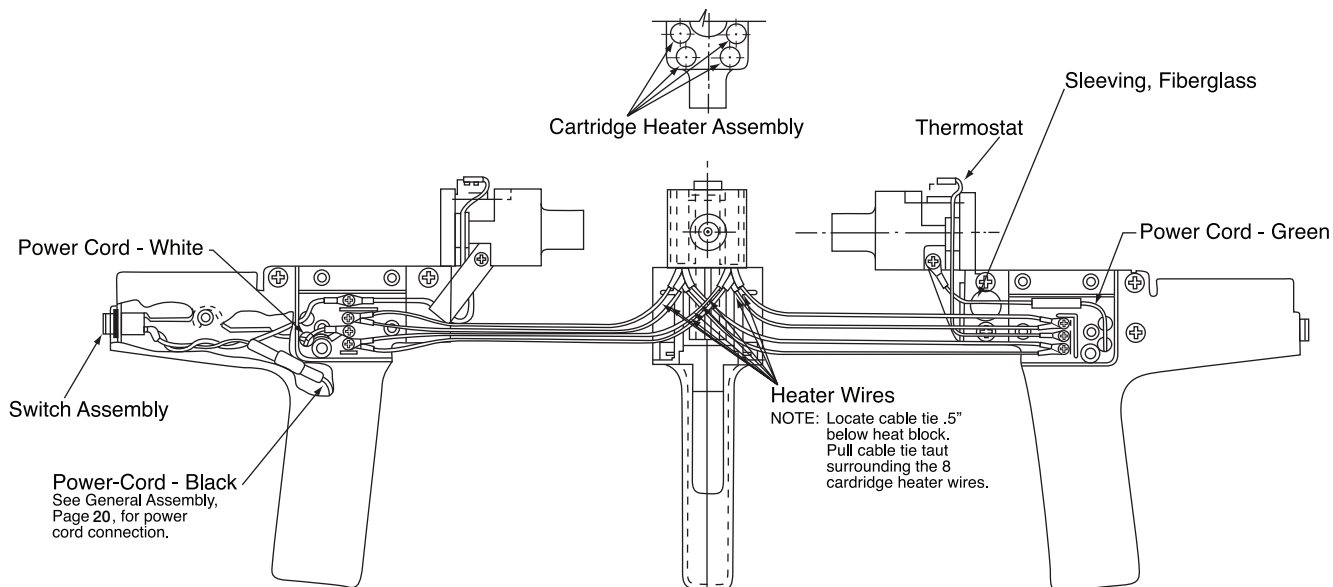

Wiring System

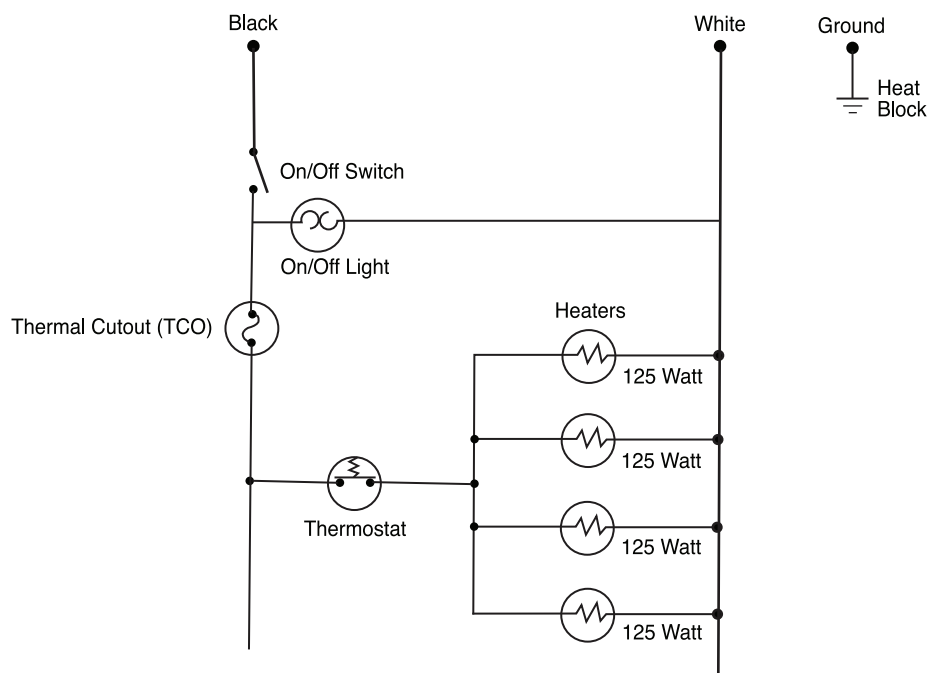

Flow control of adhesive with your new 3M™ Scotch-Weld™ Hot Melt Applicator PG II LT is easy. Any operator familiar with the control devices should be able to adjust the applicator for desired flow. To adjust adhesive flow, a combination of these control methods can be used.

The four control devices are:

1. Speed of 3M Scotch-Weld Hot Melt Applicator PG II LT movement.
2. The trigger.
3. The applicator tip.
4. Air pressure.

The trigger of the applicator is uniquely designed to allow for variable adhesive control. By pulling the trigger slowly to the rear, you can observe the start of adhesive flow. As you continue to pull the trigger rearward, increasing amounts of adhesive are dispensed.

Your 3M Scotch-Weld Hot Melt Applicator PG II LT is equipped with a 9921 (.093”) tip as a standard equipment. This tip will provide maximum flow for all 3M™ Scotch-Weld™ Hot Melt LM Adhesives. The brass extension tip (9946) will allow for maximum **control** of all the 3M Scotch-Weld Hot Melt LM Adhesives and substantially reduce initial surge. This is accomplished at a **decrease** in flow rate. Speed of movement is the preferred means to control flow. In the event that this is inappropriate for your operation, additional accessory tips are available.

Note

DO NOT REDUCE AIR PRESSURE BELOW 40 PSI. If low adhesive flow occurs when operating at reduced air pressure, return to maximum (80 psi) and run at least one cartridge of adhesive through the applicator and then return to the lower pressure.

3M Scotch-Weld Hot Melt Applicator PG II LT Tips

Tip No.	Description
9913	2 Hole Spreader
9916	3 Hole Spreader
9917	3 Hole 1” Spreader
9921	.093” Fluted
9922	.063” Fluted
9726	“T” Tip P/G II
9940	.125” Fluted Tip
9946	.072” Brass Extension
9727	“L” Tip P/G II

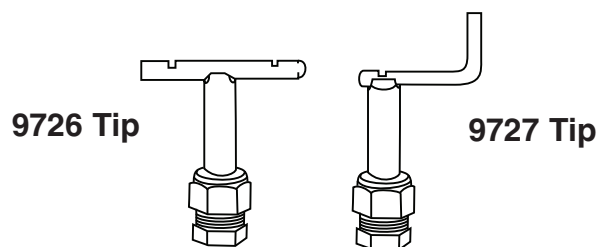

9726 “T” tip for RSC carton closing and other uses.
9727 “L” tip for FOL carton closing and other uses.

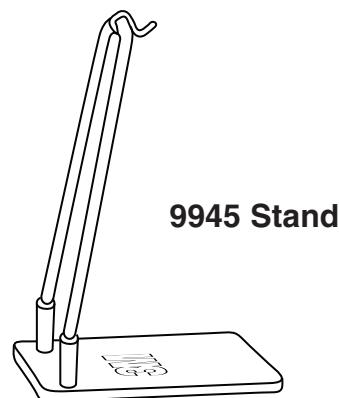

9945 heavy-duty bench stand holds 3M Scotch-Weld Hot Melt Applicator PG II LT in proper position when the applicator is not in use.

Accessories

Bench Mounted Systems for 3M™ Scotch-Weld™ Hot Melt Applicator PG II LT

A special bench mount assembly is available which allows the 3M Scotch-Weld Hot Melt Applicator PG II LT to be mounted in a 45° position and operated with a foot pedal. It is adjustable to allow positioning of the nozzle tip from a minimum of 9 1/2" to a maximum of 15 1/2" from the bench top. A nozzle adapter that directs adhesive flow straight down is included in addition to the foot pedal unit.

Speedloader Magazine Feed for 3M Scotch-Weld Hot Melt Applicator PG II LT

The 3M Scotch-Weld Hot Melt Applicator PG II LT can be modified into a semi-automatic loading mode by the addition of the Speedloader Magazine Feed. By simply pushing a lever to the rear, the magazine feeds a new stick of adhesive into the melt chamber. The magazine holds 12 3M™ Scotch-Weld™ Hot Melt LM Adhesives Sticks, reduces the need for frequent reloading and helps increase production. It is ideal for hands-free benchtop applications in packaging and assembly.

Bench mounted 3M Scotch-Weld Hot Melt Applicator PG II LT with Speedloader Magazine Feed.

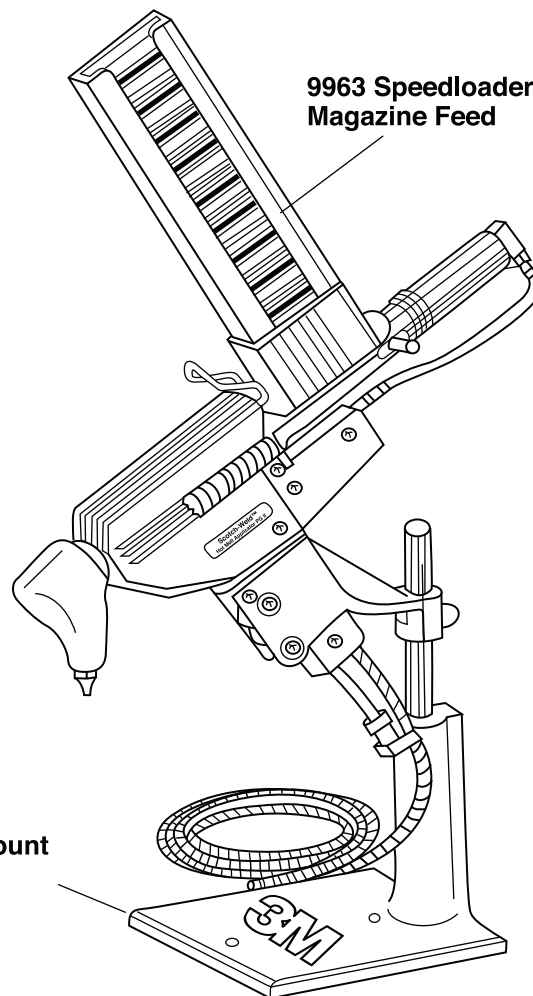

9276 Benchmount

9277 Foot Pedal Assembly (place on floor)

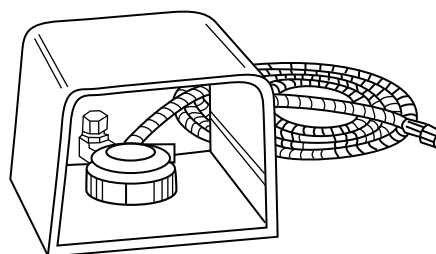

During warranty period

Contact your nearest 3M Sales Branch or 3M™ Scotch-Weld™ Hot Melt Adhesives distributor

After warranty period

The 3M™ Scotch-Weld™ Hot Melt Applicator PG II LT has been engineered to be durable and reliable. Recognizing that it will eventually need maintenance, we have made it easy to disassemble and repair. Step by step repair instructions are detailed in this manual, pages 13 thru 19. Also provided are simple line drawings and exploded views.

Should your 3M Scotch-Weld Hot Melt Applicator PG II LT require repair, you can order repair part kits from your local 3M Scotch-Weld Hot Melt Adhesives distributor or from the nearest 3M Sales Branch listed on the back cover.

If you do not wish to make your own repair, check with your local distributor. Many of our 3M Scotch-Weld Hot Melt Adhesives distributors have in-house repair capability.

3M offers a “Refurbish Program.” Information on costs and details on 3M’s Refurbishing Program can be obtained by contacting your nearest 3M Sales Branch.



RoHS compliant means that the product or part does not contain any of the substances in excess of the maximum concentration values in EU Directive 2002/95/EC, as amended by Commission Decision 2005/618/EC, unless the substance is in an application that is exempt under RoHS. Unless otherwise stated by 3M in writing, this information represents 3M’s knowledge and belief based on information provided by third party suppliers to 3M.

Important Notice: User is responsible for determining whether the 3M Scotch-Weld Hot Melt Applicator PG II LT is fit for a particular purpose and suitable for user’s method of application.

Warranty: 3M warrants for a period of 12 months from the date of use or purchase, whichever occurs first, that the 3M Scotch-Weld Hot Melt Applicator PG II LT will be free of defects in material and workmanship. 3M MAKES NO OTHER WARRANTIES, EXPRESS OR IMPLIED, INCLUDING, BUT NOT LIMITED TO, ANY IMPLIED WARRANTY OF MERCHANTABILITY OR FITNESS FOR A PARTICULAR PURPOSE OR ANY IMPLIED WARRANTY ARISING OUT OF A COURSE OF DEALING, CUSTOM, OR USAGE OF TRADE. This warranty does not cover routine maintenance, normal wear and tear, or damage resulting from accident, misuse, alteration, corrosion, lack of reasonable care, service performed by an unauthorized repair service, use of unauthorized replacement parts or accessories, installation, use, operation, or maintenance not in accordance with 3M recommended procedures, or use of adhesive cartridges not manufactured by 3M or not subject to 3M quality standards.

Limitation of Remedies: If the 3M Scotch-Weld Hot Melt Applicator PG II LT is proved to be defective within the warranty period stated above, THE EXCLUSIVE REMEDY, AT 3M’S OPTION, SHALL BE TO REFUND THE PURCHASE PRICE OF OR TO REPAIR OR REPLACE THE DEFECTIVE 3M APPLICATOR, provided that the defective applicator is, at 3M’s choice, returned immediately to 3M or an authorized service representative designated by 3M, or made available at user’s premises in a location suitable for servicing.

Limitation of Liability

3M shall not otherwise be liable for any losses or damages, whether direct, indirect, special, incidental or consequential, regardless of the legal or equitable theory asserted, including contract, negligence, warranty, or strict liability.



Компания «ЭлектроПласт» предлагает заключение долгосрочных отношений при поставках импортных электронных компонентов на взаимовыгодных условиях!

Наши преимущества:

- Оперативные поставки широкого спектра электронных компонентов отечественного и импортного производства напрямую от производителей и с крупнейших мировых складов;
- Поставка более 17-ти миллионов наименований электронных компонентов;
- Поставка сложных, дефицитных, либо снятых с производства позиций;
- Оперативные сроки поставки под заказ (от 5 рабочих дней);
- Экспресс доставка в любую точку России;
- Техническая поддержка проекта, помощь в подборе аналогов, поставка прототипов;
- Система менеджмента качества сертифицирована по Международному стандарту ISO 9001;
- Лицензия ФСБ на осуществление работ с использованием сведений, составляющих государственную тайну;
- Поставка специализированных компонентов (Xilinx, Altera, Analog Devices, Intersil, Interpoint, Microsemi, Aeroflex, Peregrine, Syfer, Eurofarad, Texas Instrument, Miteq, Cobham, E2V, MA-COM, Hittite, Mini-Circuits, General Dynamics и др.);

Помимо этого, одним из направлений компании «ЭлектроПласт» является направление «Источники питания». Мы предлагаем Вам помощь Конструкторского отдела:

- Подбор оптимального решения, техническое обоснование при выборе компонента;
- Подбор аналогов;
- Консультации по применению компонента;
- Поставка образцов и прототипов;
- Техническая поддержка проекта;
- Защита от снятия компонента с производства.



Как с нами связаться

Телефон: 8 (812) 309 58 32 (многоканальный)

Факс: 8 (812) 320-02-42

Электронная почта: org@eplast1.ru

Адрес: 198099, г. Санкт-Петербург, ул. Калинина, дом 2, корпус 4, литера А.