



# PCA9575

16-bit I<sup>2</sup>C-bus and SMBus, level translating, low voltage GPIO with reset and interrupt

Rev. 4.4 — 28 October 2019

Product data sheet

## 1. General description

The PCA9575 is a CMOS device that provides 16 bits of General Purpose parallel Input/Output (GPIO) expansion in low voltage processor and handheld battery powered mobile applications and was developed to enhance the NXP family of I<sup>2</sup>C-bus I/O expanders. The improvements include lower supply current, lower operating voltage of 1.1 V to 3.6 V, separate supply rails to allow voltage level translation anywhere between 1.1 V and 3.6 V, 400 kHz clock frequency, and smaller packaging. Any of the 16 I/O ports can be configured as an input or output independent of each other and default on start-up to inputs.

I/O expanders provide a simple solution when additional I/Os are needed while keeping interconnections to a minimum; for example in battery powered mobile applications and clamshell devices for interfacing to sensors, push buttons, keypad, etc. In addition to providing a flexible set of GPIOs, it simplifies interconnection of a processor running at one voltage level to I/O devices operating at a different (usually higher) voltage level. PCA9575 has built-in level shifting feature that makes these devices extremely flexible in mixed signal environments where communication between incompatible I/Os is required. The core of PCA9575 can operate at a voltage as low as 1.1 V while each I/O bank can operate in the range 1.1 V to 3.6 V. Bus hold with programmable on-chip pull-up or pull-down feature for I/Os is also provided.

The output stage consists of two banks each of 8-bit configuration registers, input registers, interrupt mask registers, output registers, bus-hold and pull-up/pull-down registers and polarity inversion registers. These registers allow the system master to program and configure 16 GPIOs through the I<sup>2</sup>C-bus.

The system master can enable the I/Os as either inputs or outputs by writing to the I/O configuration register bits. The data for each input or output is kept in the corresponding Input or Output register. The polarity of the read registers can be inverted with the Polarity Inversion register (active HIGH or active LOW operation). Either a bus-hold function or pull-up/pull-down feature can be selected by programming corresponding registers. The bus-hold provides a valid logic level when the I/O bus is not actively driven. When bus-hold feature is not selected, the I/O ports can be configured to have pull-up or pull-down by programming the pull-up/pull-down configuration register.

An open-drain interrupt output pin ( $\overline{\text{INT}}$ ) allows monitoring of the input pins and is asserted each time a change occurs on an input port unless that port is masked (default = masked). A 'GPIO All Call' command allows programming multiple PCA9575s at the same time even if they have different individual I<sup>2</sup>C-bus addresses. This command allows optimal code programming when more than one device must be programmed with the same instruction or if all outputs must be turned on or off at the same time. The



internal Power-On Reset (POR) or hardware reset pin ( $\overline{\text{RESET}}$ ) initializes the two banks of 8 I/Os as inputs, sets the registers to their default values and initializes the device state machine. The I/O banks are held in its default state when the logic supply ( $V_{DD}$ ) is off.

The PCA9575 is available in 24-pin TSSOP, 28-pin TSSOP and HWQFN24 packages, and is specified over the  $-40\text{ }^{\circ}\text{C}$  to  $+85\text{ }^{\circ}\text{C}$  industrial temperature range, with HWQFN24 up to  $+105\text{ }^{\circ}\text{C}$ .

The 28-pin package provides four address select pins, allowing up to 16 PCA9575 devices to be connected with 16 different addresses on the same I<sup>2</sup>C-bus.

## 2. Features and benefits

- Separate supply rails for core logic and each of the two I/O banks provides voltage level shifting
- 1.1 V to 3.6 V operation with level shifting feature
- Very low standby current:  $< 2\text{ }\mu\text{A}$
- 16 configurable I/O pins organized as 2 banks that default to inputs at power-up
- Outputs:
  - ◆ Totem pole: 1 mA source and 3 mA sink
  - ◆ Independently programmable  $100\text{ k}\Omega$  pull-up or pull-down for each I/O pin
  - ◆ Open-drain active LOW interrupt ( $\overline{\text{INT}}$ ) output pin allows monitoring of logic level change of pins programmed as inputs
- Inputs:
  - ◆ Programmable bus hold provides valid logic level when inputs are not actively driven
  - ◆ Programmable Interrupt Mask Control for input pins that do not require an interrupt when their states change or to prevent spurious interrupts default to mask at power-up
  - ◆ Polarity Inversion register allows inversion of the polarity of the I/O pins when read
- 400 kHz I<sup>2</sup>C-bus serial interface
- Compliant with I<sup>2</sup>C-bus Standard-mode (100 kHz)
- Active LOW reset ( $\overline{\text{RESET}}$ ) input pin resets device to power-up default state
- GPIO All Call address allows programming of more than one device at the same time with the same parameters
- 16 programmable slave addresses using 4 address pins (28-pin TSSOP only)
- $-40\text{ }^{\circ}\text{C}$  to  $+85\text{ }^{\circ}\text{C}$  operation, with HWQFN24 up to  $+105\text{ }^{\circ}\text{C}$
- ESD protection exceeds 6000 V HBM per JESD22-A114 and 1000 V CDM per JESD22-C101
- Latch-up testing is done to JEDEC Standard JESD78 which exceeds 100 mA
- Packages offered: TSSOP28, TSSOP24, HWQFN24

### 3. Applications

- Cell phones
- Media players
- Multi-voltage environments
- Battery operated mobile gadgets
- Motherboards
- Servers
- RAID systems
- Industrial control
- Medical equipment
- PLCs
- Gaming machines
- Instrumentation and test measurement

### 4. Ordering information

Table 1. Ordering information

| Type number | Topside marking | Package |   |          |
|-------------|-----------------|---------|---|----------|
|             |                 | Name    | Description   | Version  |
| PCA9575PW2  | PA9575PW2       | TSSOP28 | plastic thin shrink small outline package; 28 leads; body width 4.4 mm                                  | SOT361-1 |
| PCA9575PW1  | PA9575PW1       | TSSOP24 | plastic thin shrink small outline package; 24 leads; body width 4.4 mm                                  | SOT355-1 |
| PCA9575HF   | 575F            | HWQFN24 | plastic thermal enhanced very very thin quad flat package; no leads; 24 terminals; body 4 × 4 × 0.75 mm | SOT994-1 |

#### 4.1 Ordering options

Table 2. Ordering options

| Type number | Orderable part number | Package | Packing method                       | Minimum order quantity | Temperature                          |
|-------------|-----------------------|---------|--------------------------------------|------------------------|--------------------------------------|
| PCA9575PW2  | PCA9575PW2,118        | TSSOP28 | Reel 13" Q1/T1<br>*Standard mark SMD | 2500                   | T <sub>amb</sub> = -40 °C to +85 °C  |
| PCA9575PW1  | PCA9575PW1,118        | TSSOP24 | Reel 13" Q1/T1<br>*Standard mark SMD | 2500                   | T <sub>amb</sub> = -40 °C to +85 °C  |
| PCA9575HF   | PCA9575HF,118         | HWQFN24 | Reel 13" Q1/T1<br>*Standard mark SMD | 6000                   | T <sub>amb</sub> = -40 °C to +105 °C |

5. Block diagram

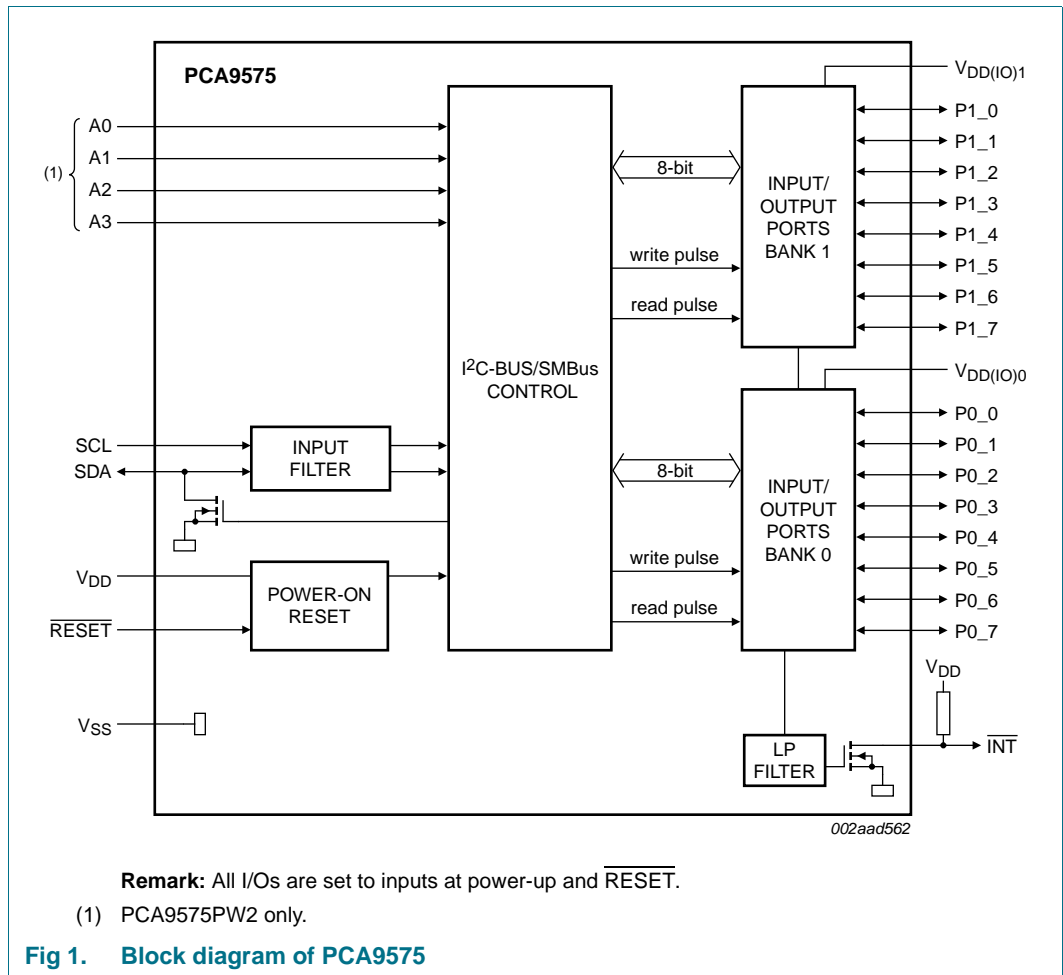

Fig 1. Block diagram of PCA9575

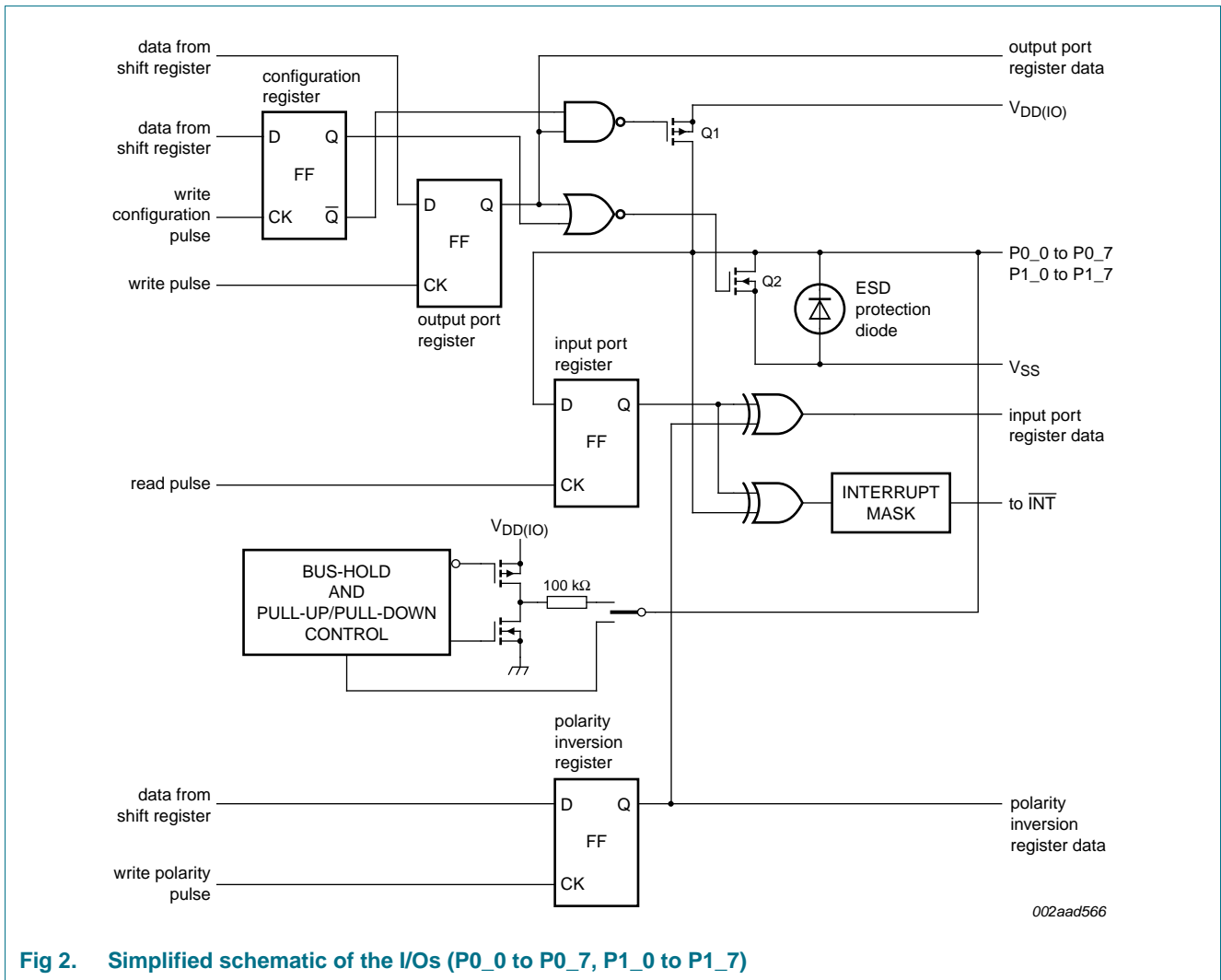
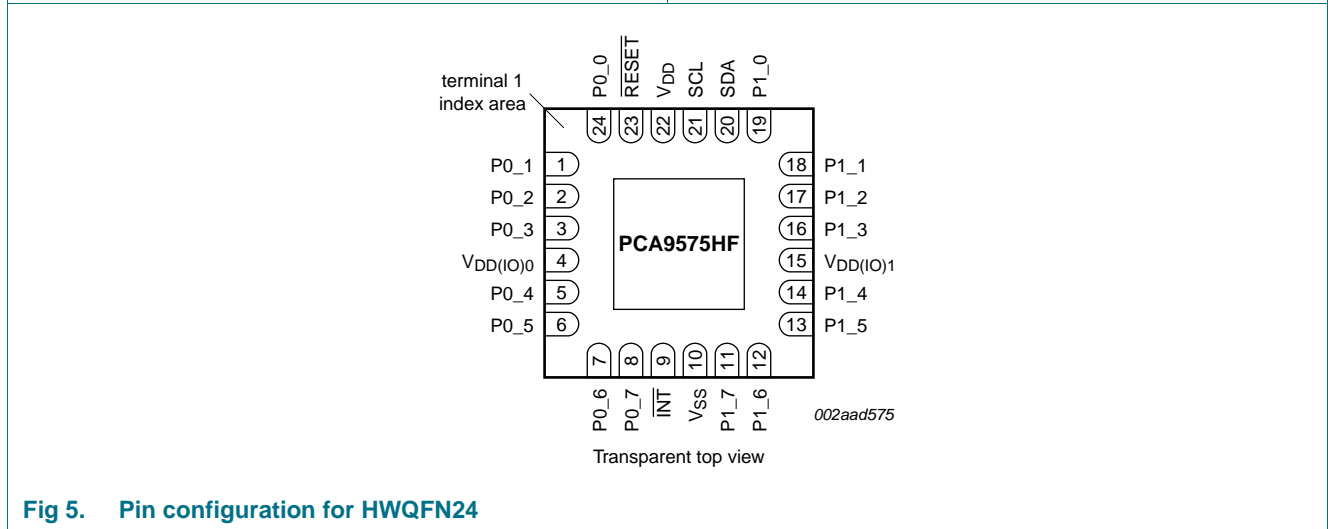
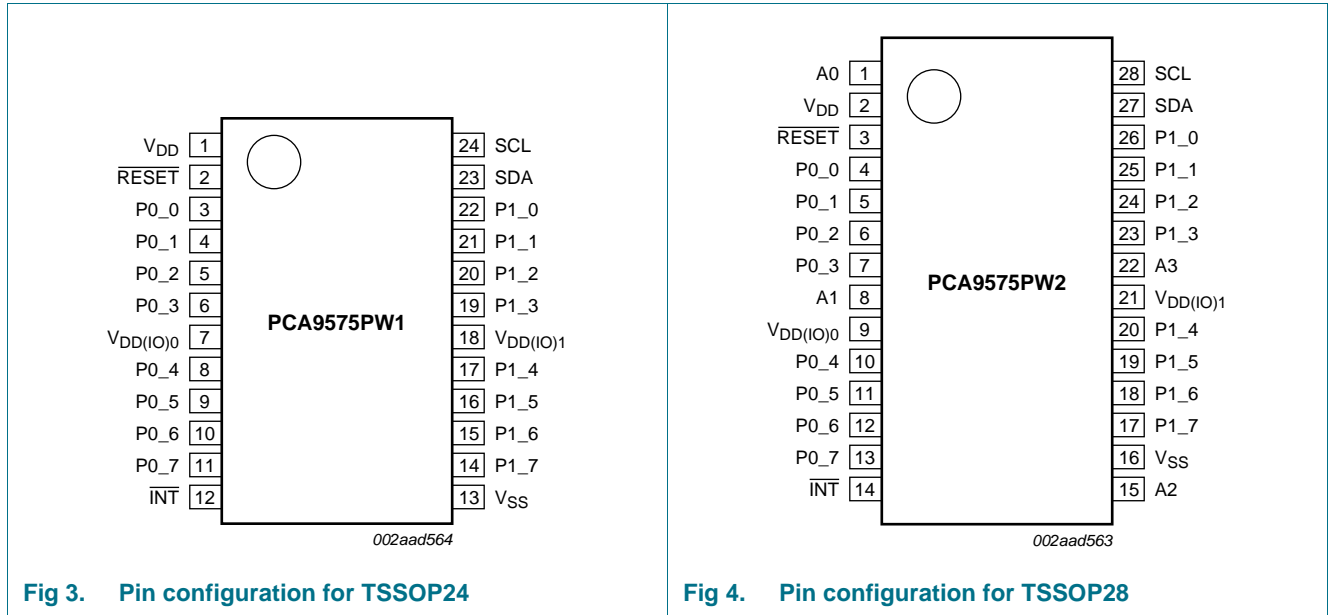

Fig 2. Simplified schematic of the I/Os (P0\_0 to P0\_7, P1\_0 to P1\_7)

## 6. Pinning information

### 6.1 Pinning



## 6.2 Pin description

Table 3. Pin description

| Symbol                    | Pin     |         |                   | Type         | Description                               |
|---------------------------|---------|---------|-------------------|--------------|---|
|                           | TSSOP28 | TSSOP24 | HWQFN24           |              |   |
| A0                        | 1       | -       | -                 | I            | address input 0                           |
| V <sub>DD</sub>           | 2       | 1       | 22                | power supply | supply voltage                            |
| $\overline{\text{RESET}}$ | 3       | 2       | 23                | I            | active LOW reset input                    |
| P0_0                      | 4       | 3       | 24                | I/O          | port 0 input/output 0                     |
| P0_1                      | 5       | 4       | 1                 | I/O          | port 0 input/output 1                     |
| P0_2                      | 6       | 5       | 2                 | I/O          | port 0 input/output 2                     |
| P0_3                      | 7       | 6       | 3                 | I/O          | port 0 input/output 3                     |
| A1                        | 8       | -       | -                 | I            | address input 1                           |
| V <sub>DD(I/O)0</sub>     | 9       | 7       | 4                 | power supply | I/O supply voltage for bank 0             |
| P0_4                      | 10      | 8       | 5                 | I/O          | port 0 input/output 0                     |
| P0_5                      | 11      | 9       | 6                 | I/O          | port 0 input/output 1                     |
| P0_6                      | 12      | 10      | 7                 | I/O          | port 0 input/output 2                     |
| P0_7                      | 13      | 11      | 8                 | I/O          | port 0 input/output 3                     |
| $\overline{\text{INT}}$   | 14      | 12      | 9                 | O            | interrupt output (open-drain; active LOW) |
| A2                        | 15      | -       | -                 | I            | address input 2                           |
| V <sub>SS</sub>           | 16      | 13      | 10 <sup>[1]</sup> | ground       | supply ground                             |
| P1_7                      | 17      | 14      | 11                | I/O          | port 1 input/output 4                     |
| P1_6                      | 18      | 15      | 12                | I/O          | port 1 input/output 5                     |
| P1_5                      | 19      | 16      | 13                | I/O          | port 1 input/output 6                     |
| P1_4                      | 20      | 17      | 14                | I/O          | port 1 input/output 7                     |
| V <sub>DD(I/O)1</sub>     | 21      | 18      | 15                | power supply | I/O supply voltage for bank 1             |
| A3                        | 22      | -       | -                 | I            | address input 3                           |
| P1_3                      | 23      | 19      | 16                | I/O          | port 1 input/output 3                     |
| P1_2                      | 24      | 20      | 17                | I/O          | port 1 input/output 2                     |
| P1_1                      | 25      | 21      | 18                | I/O          | port 1 input/output 1                     |
| P1_0                      | 26      | 22      | 19                | I/O          | port 1 input/output 0                     |
| SDA                       | 27      | 23      | 20                | I/O          | serial data line                          |
| SCL                       | 28      | 24      | 21                | I            | serial clock line                         |

- [1] HWQFN24 package die supply ground is connected to both V<sub>SS</sub> pin and exposed center pad. V<sub>SS</sub> pin must be connected to supply ground for proper device operation. For enhanced thermal, electrical, and board level performance, the exposed pad must be soldered to the board using a corresponding thermal pad on the board and for proper heat conduction through the board, thermal vias must be incorporated in the PCB in the thermal pad region.

## 7. Functional description

### 7.1 I/O ports

The 16 I/O ports are organized as two banks of 8 ports each. The system master can enable the I/Os as either inputs or outputs by writing to the I/O configuration register bits. The data for each input or output is kept in the corresponding Input or Output register. The polarity of the read register can be inverted with the Polarity Inversion register. Either a bus-hold function or pull-up/pull-down feature can be selected by programming corresponding registers. A bus-hold provides a valid logic level when the I/O bus is not actively driven. It consists of a pair of buffers, one being weak (low drive-strength), that latch the input at the last driven value. This prevents the input from floating while it is being driven by a 3-state output. Latching the last valid logic state of input prevents it from settling at a midpoint between  $V_{DD}$  and ground that in turn consumes power. An active bus driver can easily override the logic level set by the bus-keeper.

When bus-hold feature is not selected, the I/O ports can be configured to have pull-up or pull-down by programming the pull-up/pull-down configuration register.

### 7.2 Device address

Following a START condition, the bus master must send the address of the slave it is accessing and the operation it wants to perform (read or write). Address configuration for the device depends on the package type chosen. The device offered in a 24-pin package has a fixed slave address for the PCA9575 as shown in [Figure 6](#).

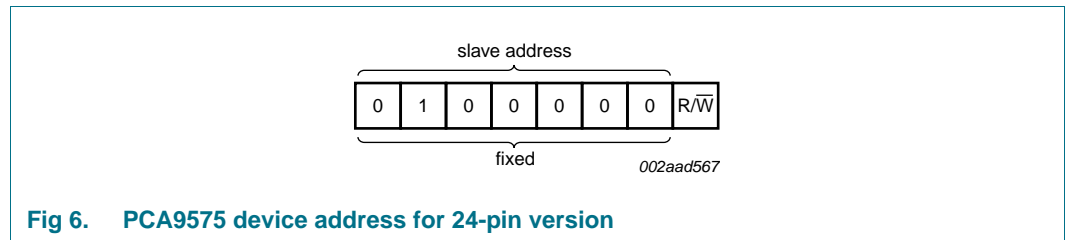

**Fig 6. PCA9575 device address for 24-pin version**

The last bit of the first byte defines the operation to be performed. When set to logic 1 a read is selected, while logic 0 selects a write operation.

The slave address for the 28-pin version of the PCA9575 is shown in [Figure 7](#).

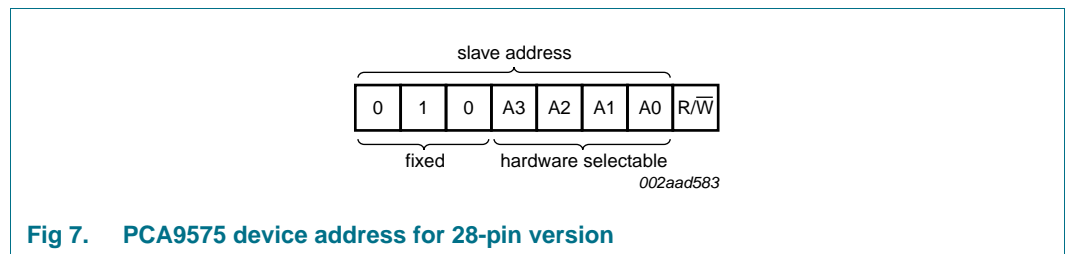
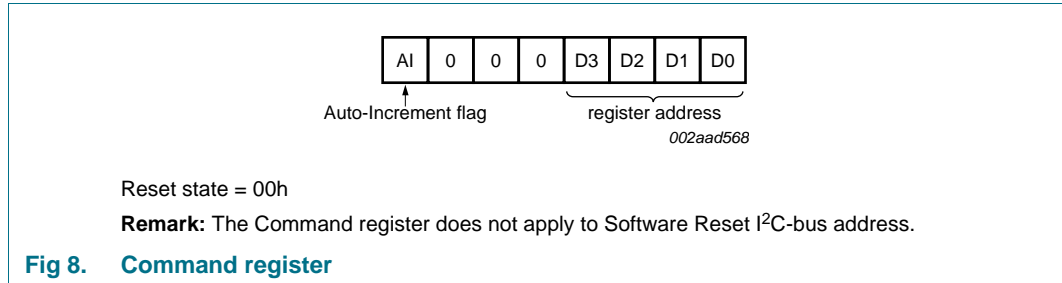

**Fig 7. PCA9575 device address for 28-pin version**



### 7.3 Command register

Following the successful acknowledgement of the slave address + R/W bit, the bus master sends a byte to the PCA9575, which is stored in the Command register.



The lowest 4 bits are used as a pointer to determine which register is accessed. Only a Command register code with the 4 least significant bits equal to the 16 allowable values as defined in [Table 4 “Register summary”](#) is acknowledged. Reserved or undefined command codes are not acknowledged. At power-up, this register defaults to 00h, with the AI bit set to logic 0, and the lowest 4 bits set to logic 0.

If the Auto-Increment flag is set (AI = 1), the 4 least significant bits of the Command register are automatically incremented after a read or write. This allows the user to program and/or read the 16 command registers (listed in [Table 4](#)) sequentially. It will then roll over to register 00h after the last register is accessed and the selected registers are overwritten or re-read.

If the Auto-Increment flag is cleared (AI = 0), the 4 least significant bits are not incremented after data is read or written, only one register will be repeatedly read or written.

### 7.4 Register definitions

**Table 4. Register summary**

| Register number | D3 | D2 | D1 | D0 | Name   | Type       | Function                                   |
|-----------------|----|----|----|----|--------|------------|--|
| 00h             | 0  | 0  | 0  | 0  | IN0    | read only  | Input port 0 register                      |
| 01h             | 0  | 0  | 0  | 1  | IN1    | read only  | Input port 1 register                      |
| 02h             | 0  | 0  | 1  | 0  | INVRT0 | read/write | Polarity inversion port 0 register         |
| 03h             | 0  | 0  | 1  | 1  | INVRT1 | read/write | Polarity inversion port 1 register         |
| 04h             | 0  | 1  | 0  | 0  | BKEN0  | read/write | Bus-hold enable 0 register                 |
| 05h             | 0  | 1  | 0  | 1  | BKEN1  | read/write | Bus-hold enable 1 register                 |
| 06h             | 0  | 1  | 1  | 0  | PUPD0  | read/write | Pull-up/pull-down selector port 0 register |
| 07h             | 0  | 1  | 1  | 1  | PUPD1  | read/write | Pull-up/pull-down selector port 1 register |
| 08h             | 1  | 0  | 0  | 0  | CFG0   | read/write | Configuration port 0 register              |
| 09h             | 1  | 0  | 0  | 1  | CFG1   | read/write | Configuration port 1 register              |
| 0Ah             | 1  | 0  | 1  | 0  | OUT0   | read/write | Output port 0 register                     |
| 0Bh             | 1  | 0  | 1  | 1  | OUT1   | read/write | Output port 1 register                     |
| 0Ch             | 1  | 1  | 0  | 0  | MSK0   | read/write | Interrupt mask port 0 register             |

Table 4. Register summary ...continued

| Register number | D3 | D2 | D1 | D0 | Name  | Type       | Function                         |
|-----------------|----|----|----|----|-------|------------|----------------------------------|
| 0Dh             | 1  | 1  | 0  | 1  | MSK1  | read/write | Interrupt mask port 1 register   |
| 0Eh             | 1  | 1  | 1  | 0  | INTS0 | read only  | Interrupt status port 0 register |
| 0Fh             | 1  | 1  | 1  | 1  | INTS1 | read only  | Interrupt status port 1 register |

## 7.5 Writing to port registers

Data is transmitted to the PCA9575 by sending the device address and setting the least significant bit to logic 0 (see [Figure 6](#) or [Figure 7](#) for device address). The command byte is sent after the address and determines which register receives the data following the command byte. Each 8-bit register may be updated independently of the other registers.

## 7.6 Reading the port registers

In order to read data from the PCA9575, the bus master must first send the PCA9575 address with the least significant bit set to a logic 0 (see [Figure 6](#) or [Figure 7](#) for device address). The command byte is sent after the address and determines which register is accessed. After a restart, the device address is sent again but this time, the least significant bit is set to logic 1. Data from the register defined by the command byte will then be sent by the PCA9575. Data is clocked into the register on the falling edge of the acknowledge clock pulse. After the first byte is read, additional bytes may be read using the auto-increment feature.

### 7.6.1 Register 0 - Input port 0 register

This register is read-only. It reflects the incoming logic levels of the pins, regardless of whether the pin is defined as an input or an output by the Configuration register. Writes to this register are acknowledged but have no effect.

The default 'X' is determined by the externally applied logic level.

Table 5. Register 0 - Input port 0 register (address 00h) bit description

| Bit | Symbol | Access    | Value | Description                                  |
|-----|--------|-----------|-------|--|
| 7   | IO0.7  | read only | X     | determined by externally applied logic level |
| 6   | IO0.6  | read only | X     |  |
| 5   | IO0.5  | read only | X     |  |
| 4   | IO0.4  | read only | X     |  |
| 3   | IO0.3  | read only | X     |  |
| 2   | IO0.2  | read only | X     |  |
| 1   | IO0.1  | read only | X     |  |
| 0   | IO0.0  | read only | X     |  |

### 7.6.2 Register 1 - Input port 1 register

This register is read-only. It reflects the incoming logic levels of the pins, regardless of whether the pin is defined as an input or an output by the Configuration register. Writes to this register are acknowledged but have no effect.

The default 'X' is determined by the externally applied logic level.

**Table 6. Register 1 - Input port 1 register (address 01h) bit description**

| Bit | Symbol | Access    | Value | Description                                  |
|-----|--------|-----------|-------|--|
| 7   | IO1.7  | read only | X     | determined by externally applied logic level |
| 6   | IO1.6  | read only | X     |  |
| 5   | IO1.5  | read only | X     |  |
| 4   | IO1.4  | read only | X     |  |
| 3   | IO1.3  | read only | X     |  |
| 2   | IO1.2  | read only | X     |  |
| 1   | IO1.1  | read only | X     |  |
| 0   | IO1.0  | read only | X     |  |

### 7.6.3 Register 2 - Polarity inversion port 0 register

This register allows the user to invert the polarity of the Input port register data. If a bit in this register is set (written with '1'), the corresponding Input port data is inverted. If a bit in this register is cleared (written with a '0'), the Input port data polarity is retained.

**Table 7. Register 2 - Polarity Inversion port 0 register (address 02h) bit description**

Legend: \* default value.

| Bit | Symbol | Access | Value | Description  |
|-----|--------|--------|-------|--|
| 7   | N0.7   | R/W    | 0*    | inverts polarity of Input port 0 register data<br>0 = Input port 0 register data retained (default value)<br>1 = Input port 0 register data inverted |
| 6   | N0.6   | R/W    | 0*    |  |
| 5   | N0.5   | R/W    | 0*    |  |
| 4   | N0.4   | R/W    | 0*    |  |
| 3   | N0.3   | R/W    | 0*    |  |
| 2   | N0.2   | R/W    | 0*    |  |
| 1   | N0.1   | R/W    | 0*    |  |
| 0   | N0.0   | R/W    | 0*    |  |

### 7.6.4 Register 3 - Polarity inversion port 1 register

This register allows the user to invert the polarity of the Input port register data. If a bit in this register is set (written with '1'), the corresponding Input port data is inverted. If a bit in this register is cleared (written with a '0'), the Input port data polarity is retained.

**Table 8. Register 3 - Polarity Inversion port 1 register (address 03h) bit description**

Legend: \* default value.

| Bit | Symbol | Access | Value | Description  |
|-----|--------|--------|-------|--|
| 7   | N1.7   | R/W    | 0*    | inverts polarity of Input port 1 register data<br>0 = Input port 1 register data retained (default value)<br>1 = Input port 1 register data inverted |
| 6   | N1.6   | R/W    | 0*    |  |
| 5   | N1.5   | R/W    | 0*    |  |
| 4   | N1.4   | R/W    | 0*    |  |
| 3   | N1.3   | R/W    | 0*    |  |
| 2   | N1.2   | R/W    | 0*    |  |
| 1   | N1.1   | R/W    | 0*    |  |
| 0   | N1.0   | R/W    | 0*    |  |

### 7.6.5 Register 4 - Bus-hold/pull-up/pull-down enable 0 register

Bit 0 of this register allows the user to enable/disable the bus-hold feature for the I/O pins. Setting the bit 0 to logic 1 enables bus-hold feature for the I/O bank 0. In this mode, the pull-up/pull-downs are disabled for I/O bank 0. Setting the bit 0 to logic 0 disables bus-hold feature.

Bit 1 of this register allows the user to enable/disable pull-up/pull-downs on the I/O pins. Setting the bit 1 to logic 1 enables selection of pull-up/pull-down using Register 6. Setting the bit 1 to logic 0 disables pull-up/pull-downs on the I/O bank 0 pins and contents of Register 6 have no effect on the I/O.

**Table 9. Register 4 - Bus-hold/pull-up/pull-down enable 0 register (address 04h) bit description**

Legend: \* default value.

| Bit | Symbol | Access | Value | Description  |
|-----|--------|--------|-------|--|
| 7   | E0.7   | R/W    | X     | not used   |
| 6   | E0.6   | R/W    | X     |  |
| 5   | E0.5   | R/W    | X     |  |
| 4   | E0.4   | R/W    | X     |  |
| 3   | E0.3   | R/W    | X     |  |
| 2   | E0.2   | R/W    | X     |  |
| 1   | E0.1   | R/W    | 0*    | allows the user to enable/disable pull-up/pull-downs on the I/O bank 0 pins<br>0 = disables pull-up/pull-downs on the I/O bank 0 pins and contents of Register 6 have no effect on the I/O bank 0 (default value)<br>1 = enables selection of pull-up/pull-down using Register 6 |
| 0   | E0.0   | R/W    | 0*    | allows user to enable/disable the bus-hold feature for the I/O bank 0 pins<br>0 = disables bus-hold feature (default value)<br>1 = enables bus-hold feature  |

### 7.6.6 Register 5 - Bus-hold/pull-up/pull-down enable 1 register

Bit 0 of this register allows the user to enable/disable the bus-hold feature for the I/O pins. Setting the bit 0 to logic 1 enables bus-hold feature for the I/O bank 1. In this mode, the pull-up/pull-downs are disabled for I/O bank 1. Setting the bit 0 to logic 0 disables bus-hold feature.

Bit 1 of this register allows the user to enable/disable pull-up/pull-downs on the I/O pins. Setting the bit 1 to logic 1 enables selection of pull-up/pull-down using Register 7. Setting the bit 1 to logic 0 disables pull-up/pull-downs on the I/O bank 1 pins and contents of Register 7 have no effect on the I/O.

**Table 10. Register 5 - Bus-hold/pull-up/pull-down enable 1 register (address 05h) bit description**

Legend: \* default value.

| Bit | Symbol | Access | Value | Description  |
|-----|--------|--------|-------|--|
| 7   | E1.7   | R/W    | X     | not used   |
| 6   | E1.6   | R/W    | X     |  |
| 5   | E1.5   | R/W    | X     |  |
| 4   | E1.4   | R/W    | X     |  |
| 3   | E1.3   | R/W    | X     |  |
| 2   | E1.2   | R/W    | X     |  |
| 1   | E1.1   | R/W    | 0*    | allows the user to enable/disable pull-up/pull-downs on the I/O bank 1 pins<br>0 = disables pull-up/pull-downs on the I/O bank 1 pins and contents of Register 7 have no effect on the I/O bank 0 (default value)<br>1 = enables selection of pull-up/pull-down using Register 7 |
| 0   | E1.0   | R/W    | 0*    | allows user to enable/disable the bus-hold feature for the I/O bank 1 pins<br>0 = disables bus-hold feature (default value)<br>1 = enables bus-hold feature  |

### 7.6.7 Register 6 - Pull-up/pull-down select port 0 register

When bus-hold feature is not selected and bit 1 of Register 4 is set to logic 1, the I/O port 0 can be configured to have pull-up or pull-down by programming the pull-up/pull-down register. Setting a bit to logic 1 selects a 100 k $\Omega$  pull-up resistor for that I/O pin. Setting a bit to logic 0 selects a 100 k $\Omega$  pull-down resistor for that I/O pin. If the bus-hold feature is enabled, writing to this register has no effect on pull-up/pull-down selection.

**Table 11. Register 6 - Pull-up/pull-down select port 0 register (address 06h) bit description**  
Legend: \* default value.

| Bit | Symbol | Access | Value | Description  |
|-----|--------|--------|-------|--|
| 7   | P0.7   | R/W    | 1*    | configures I/O port 0 pin to have pull-up or pull-down when bus-hold feature not selected and bit 1 of Register 4 is logic 1<br>0 = selects a 100 k $\Omega$ pull-down resistor for that I/O pin<br>1 = selects a 100 k $\Omega$ pull-up resistor for that I/O pin (default value) |
| 6   | P0.6   | R/W    | 1*    |  |
| 5   | P0.5   | R/W    | 1*    |  |
| 4   | P0.4   | R/W    | 1*    |  |
| 3   | P0.3   | R/W    | 1*    |  |
| 2   | P0.2   | R/W    | 1*    |  |
| 1   | P0.1   | R/W    | 1*    |  |
| 0   | P0.0   | R/W    | 1*    |  |

### 7.6.8 Register 7 - Pull-up/pull-down select port 1 register

When bus-hold feature is not selected and bit 1 of Register 5 is set to logic 1, the I/O port 1 can be configured to have pull-up or pull-down by programming the pull-up/pull-down register. Setting a bit to logic 1 selects a 100 k $\Omega$  pull-up resistor for that I/O pin. Setting a bit to logic 0 selects a 100 k $\Omega$  pull-down resistor for that I/O pin. If the bus-hold feature is enabled, writing to this register has no effect on pull-up/pull-down selection.

**Table 12. Register 7 - Pull-up/pull-down select port 1 register (address 07h) bit description**  
Legend: \* default value.

| Bit | Symbol | Access | Value | Description  |
|-----|--------|--------|-------|--|
| 7   | P1.7   | R/W    | 1*    | configures I/O port 1 pin to have pull-up or pull-down when bus-hold feature not selected and bit 1 of Register 5 is logic 1<br>0 = selects a 100 k $\Omega$ pull-down resistor for that I/O pin<br>1 = selects a 100 k $\Omega$ pull-up resistor for that I/O pin (default value) |
| 6   | P1.6   | R/W    | 1*    |  |
| 5   | P1.5   | R/W    | 1*    |  |
| 4   | P1.4   | R/W    | 1*    |  |
| 3   | P1.3   | R/W    | 1*    |  |
| 2   | P1.2   | R/W    | 1*    |  |
| 1   | P1.1   | R/W    | 1*    |  |
| 0   | P1.0   | R/W    | 1*    |  |

### 7.6.9 Register 8 - Configuration port 0 register

This register configures the direction of the I/O pins. If a bit in this register is set (written with logic 1), the corresponding port 0 pin is enabled as an input with high-impedance output driver. If a bit in this register is cleared (written with logic 0), the corresponding port 0 pin is enabled as an output. At reset, the device ports are inputs.

**Table 13. Register 8 - Configuration port 0 register (address 08h) bit description**

Legend: \* default value.

| Bit | Symbol | Access | Value | Description   |
|-----|--------|--------|-------|---|
| 7   | C0.7   | R/W    | 1*    | configures the direction of the I/O pins<br>0 = corresponding port pin enabled as an output<br>1 = corresponding port pin configured as input (default value) |
| 6   | C0.6   | R/W    | 1*    |   |
| 5   | C0.5   | R/W    | 1*    |   |
| 4   | C0.4   | R/W    | 1*    |   |
| 3   | C0.3   | R/W    | 1*    |   |
| 2   | C0.2   | R/W    | 1*    |   |
| 1   | C0.1   | R/W    | 1*    |   |
| 0   | C0.0   | R/W    | 1*    |   |

### 7.6.10 Register 9 - Configuration port 1 register

This register configures the direction of the I/O pins. If a bit in this register is set (written with logic 1), the corresponding port 1 pin is enabled as an input with high-impedance output driver. If a bit in this register is cleared (written with logic 0), the corresponding port 1 pin is enabled as an output. At reset, the device ports are inputs.

**Table 14. Register 9 - Configuration port 1 register (address 09h) bit description**

Legend: \* default value.

| Bit | Symbol | Access | Value | Description   |
|-----|--------|--------|-------|---|
| 7   | C1.7   | R/W    | 1*    | configures the direction of the I/O pins<br>0 = corresponding port pin enabled as an output<br>1 = corresponding port pin configured as input (default value) |
| 6   | C1.6   | R/W    | 1*    |   |
| 5   | C1.5   | R/W    | 1*    |   |
| 4   | C1.4   | R/W    | 1*    |   |
| 3   | C1.3   | R/W    | 1*    |   |
| 2   | C1.2   | R/W    | 1*    |   |
| 1   | C1.1   | R/W    | 1*    |   |
| 0   | C1.0   | R/W    | 1*    |   |

### 7.6.11 Register 10 - Output port 0 register

This register is an output-only port. It reflects the outgoing logic levels of the pins defined as outputs by Register 8. Bit values in this register have no effect on pins defined as inputs. In turn, reads from this register reflect the value that is in the flip-flop controlling the output selection, **not** the actual pin value.

**Table 15. Register 10 - Output port 0 register (address 0Ah) bit description**

Legend: \* default value.

| Bit | Symbol | Access | Value | Description   |
|-----|--------|--------|-------|---|
| 7   | O0.7   | R/W    | 0*    | reflects outgoing logic levels of pins defined as outputs by Register 8 |
| 6   | O0.6   | R/W    | 0*    |   |
| 5   | O0.5   | R/W    | 0*    |   |
| 4   | O0.4   | R/W    | 0*    |   |
| 3   | O0.3   | R/W    | 0*    |   |
| 2   | O0.2   | R/W    | 0*    |   |
| 1   | O0.1   | R/W    | 0*    |   |
| 0   | O0.0   | R/W    | 0*    |   |

### 7.6.12 Register 11 - Output port 1 register

This register is an output-only port. It reflects the outgoing logic levels of the pins defined as outputs by Register 9. Bit values in this register have no effect on pins defined as inputs. In turn, reads from this register reflect the value that is in the flip-flop controlling the output selection, **not** the actual pin value.

**Table 16. Register 11 - Output port 1 register (address 0Bh) bit description**

Legend: \* default value.

| Bit | Symbol | Access | Value | Description   |
|-----|--------|--------|-------|---|
| 7   | O1.7   | R/W    | 0*    | reflects outgoing logic levels of pins defined as outputs by Register 9 |
| 6   | O1.6   | R/W    | 0*    |   |
| 5   | O1.5   | R/W    | 0*    |   |
| 4   | O1.4   | R/W    | 0*    |   |
| 3   | O1.3   | R/W    | 0*    |   |
| 2   | O1.2   | R/W    | 0*    |   |
| 1   | O1.1   | R/W    | 0*    |   |
| 0   | O1.0   | R/W    | 0*    |   |



### 7.6.13 Register 12 - Interrupt mask port 0 register

All the bits of Interrupt mask port 0 register are set to logic 1 upon power-on or software reset, thus disabling interrupts. Interrupts may be enabled by setting corresponding mask bits to logic 0.

**Table 17. Register 12 - Interrupt mask port 0 register (address 0Ch) bit description**

Legend: \* default value.

| Bit | Symbol | Access | Value | Description   |
|-----|--------|--------|-------|---|
| 7   | M0.7   | R/W    | 1*    | enable or disable interrupts<br>0 = enable interrupt<br>1 = disable interrupt (default value) |
| 6   | M0.6   | R/W    | 1*    |   |
| 5   | M0.5   | R/W    | 1*    |   |
| 4   | M0.4   | R/W    | 1*    |   |
| 3   | M0.3   | R/W    | 1*    |   |
| 2   | M0.2   | R/W    | 1*    |   |
| 1   | M0.1   | R/W    | 1*    |   |
| 0   | M0.0   | R/W    | 1*    |   |

### 7.6.14 Register 13 - Interrupt mask port 1 register

All the bits of Interrupt mask port 1 register are set to logic 1 upon power-on or software reset, thus disabling interrupts. Interrupts may be enabled by setting corresponding mask bits to logic 0.

**Table 18. Register 13 - Interrupt mask port 1 register (address 0Dh) bit description**

Legend: \* default value.

| Bit | Symbol | Access | Value | Description   |
|-----|--------|--------|-------|---|
| 7   | M1.7   | R/W    | 1*    | enable or disable interrupts<br>0 = enable interrupt<br>1 = disable interrupt (default value) |
| 6   | M1.6   | R/W    | 1*    |   |
| 5   | M1.5   | R/W    | 1*    |   |
| 4   | M1.4   | R/W    | 1*    |   |
| 3   | M1.3   | R/W    | 1*    |   |
| 2   | M1.2   | R/W    | 1*    |   |
| 1   | M1.1   | R/W    | 1*    |   |
| 0   | M1.0   | R/W    | 1*    |   |

### 7.6.15 Register 14 - Interrupt status port 0 register

This register is read-only. It is used to identify the source of interrupt.

**Remark:** If the interrupts are masked, this register returns all zeros.

**Table 19. Register 14 - Interrupt status port 0 register (address 0Eh) bit description**

Legend: \* default value.

| Bit | Symbol | Access    | Value | Description                    |
|-----|--------|-----------|-------|--------------------------------|
| 7   | S0.7   | read only | 0*    | identifies source of interrupt |
| 6   | S0.6   | read only | 0*    |                                |
| 5   | S0.5   | read only | 0*    |                                |
| 4   | S0.4   | read only | 0*    |                                |
| 3   | S0.3   | read only | 0*    |                                |
| 2   | S0.2   | read only | 0*    |                                |
| 1   | S0.1   | read only | 0*    |                                |
| 0   | S0.0   | read only | 0*    |                                |

### 7.6.16 Register 15 - Interrupt status port 1 register

This register is read-only. It is used to identify the source of interrupt.

**Remark:** If the interrupts are masked, this register returns all zeros.

**Table 20. Register 15 - Interrupt status port 1 register (address 0Fh) bit description**

Legend: \* default value.

| Bit | Symbol | Access    | Value | Description                    |
|-----|--------|-----------|-------|--------------------------------|
| 7   | S1.7   | read only | 0*    | identifies source of interrupt |
| 6   | S1.6   | read only | 0*    |                                |
| 5   | S1.5   | read only | 0*    |                                |
| 4   | S1.4   | read only | 0*    |                                |
| 3   | S1.3   | read only | 0*    |                                |
| 2   | S1.2   | read only | 0*    |                                |
| 1   | S1.1   | read only | 0*    |                                |
| 0   | S1.0   | read only | 0*    |                                |

## 7.7 Power-on reset

When power is applied to  $V_{DD}$ , an internal Power-On Reset (POR) holds the PCA9575 in a reset condition until  $V_{DD}$  has reached  $V_{POR}$ . At that point, the reset condition is released and the PCA9575 registers and state machine initialize to their default states. The power-on reset typically completes the reset and enables the part by the time the power supply is above  $V_{POR}$ . However, when it is required to reset the part by lowering the power supply, it is necessary to lower it below 0.2 V.

## 7.8 RESET input

A reset can be accomplished by holding the  $\overline{\text{RESET}}$  pin LOW for a minimum of  $t_{w(\text{rst})}$ . The PCA9575 registers and I<sup>2</sup>C-bus state machine are held in their default state until the  $\overline{\text{RESET}}$  input is once again HIGH.

## 7.9 Software reset

The Software Reset Call allows all the devices in the I<sup>2</sup>C-bus to be reset to the power-up state value through a specific formatted I<sup>2</sup>C-bus command. To be performed correctly, it implies that the I<sup>2</sup>C-bus is functional and that there is no device hanging the bus.

The Software Reset sequence is defined as following:

1. A START command is sent by the I<sup>2</sup>C-bus master.
2. The reserved General Call I<sup>2</sup>C-bus address '0000 000' with the R/ $\overline{W}$  bit set to 0 (write) is sent by the I<sup>2</sup>C-bus master.
3. The PCA9575 device(s) acknowledge(s) after seeing the General Call address '0000 0000' (00h) only. If the R/ $\overline{W}$  bit is set to logic 1 (read), no acknowledge is returned to the I<sup>2</sup>C-bus master.
4. Once the General Call address has been sent and acknowledged, the master sends 1 byte. The value of the byte must be equal to 06h (1000 0011). The PCA9575 acknowledges this value only. If the byte is not equal to 06h, the PCA9575 does not acknowledge it. If more than 1 byte of data is sent, the PCA9575 does not acknowledge anymore.
5. Once the right byte has been sent and correctly acknowledged, the master sends a STOP command to end the Software Reset sequence: the PCA9575 then resets to the default value (power-up value) and is ready to be addressed again within the specified bus free time. If the master sends a Repeated START instead, no reset is performed. The I<sup>2</sup>C-bus master must interpret a non-acknowledge from the PCA9575 (at any time) as a 'Software Reset Abort'. The PCA9575 does not initiate a software reset.

## 7.10 Interrupt output ( $\overline{INT}$ )

The open-drain active LOW interrupt is activated when one of the port pins changes state and the port pin is configured as an input and the interrupt on it is not masked. The interrupt is deactivated when the port pin input returns to its previous state or the Input Port register is read. It is highly recommended to program the MSK register, and the CFG registers during the initialization sequence after power-up, since any change to them during Normal mode operation may cause undesirable interrupt events to happen.

**Remark:** Changing an I/O from an output to an input may cause a false interrupt to occur if the state of the pin does not match the contents of the Input Port register. Only a Read of the Input Port register that contains the bit(s) image of the input(s) that generated the interrupt clears the interrupt condition.

## 7.11 Standby

The PCA9575 goes into standby when the I<sup>2</sup>C-bus is idle. Standby supply current is lower than 2.0  $\mu$ A (typical).

## 8. Characteristics of the I<sup>2</sup>C-bus

The I<sup>2</sup>C-bus is for 2-way, 2-line communication between different ICs or modules. The two lines are a serial data line (SDA) and a serial clock line (SCL). Both lines must be connected to a positive supply via a pull-up resistor when connected to the output stages of a device. Data transfer may be initiated only when the bus is not busy.

### 8.1 Bit transfer

One data bit is transferred during each clock pulse. The data on the SDA line must remain stable during the HIGH period of the clock pulse as changes in the data line at this time are interpreted as control signals (see [Figure 9](#)).

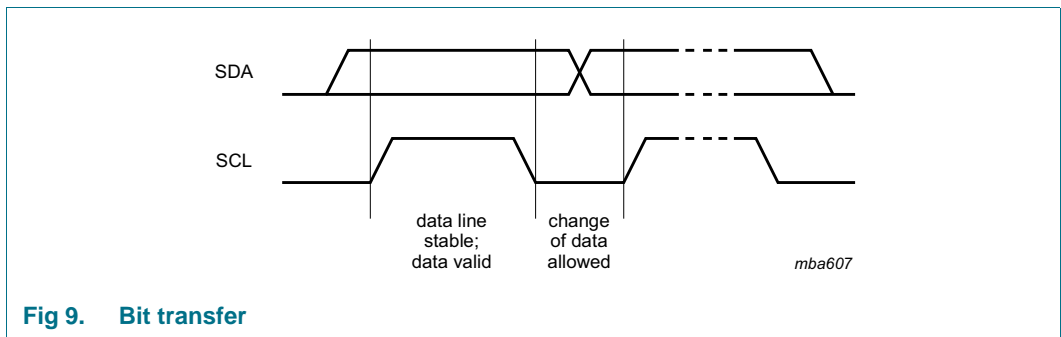

Fig 9. Bit transfer

#### 8.1.1 START and STOP conditions

Both data and clock lines remain HIGH when the bus is not busy. A HIGH-to-LOW transition of the data line while the clock is HIGH is defined as the START condition (S). A LOW-to-HIGH transition of the data line while the clock is HIGH is defined as the STOP condition (P) (see [Figure 10](#)).

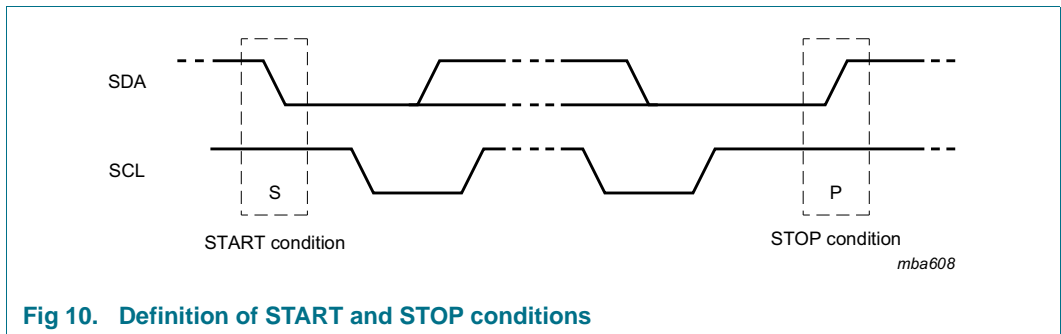

Fig 10. Definition of START and STOP conditions

### 8.2 System configuration

A device generating a message is a 'transmitter'; a device receiving is the 'receiver'. The device that controls the message is the 'master' and the devices which are controlled by the master are the 'slaves' (see [Figure 11](#)).

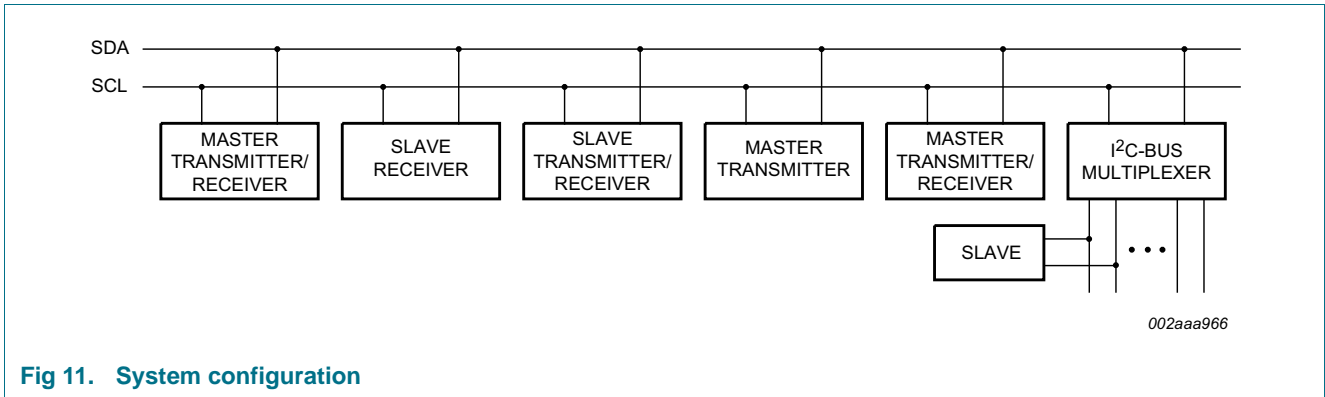

Fig 11. System configuration

### 8.3 Acknowledge

The number of data bytes transferred between the START and the STOP conditions from transmitter to receiver is not limited. Each byte of 8 bits is followed by one acknowledge bit. The acknowledge bit is a HIGH level put on the bus by the transmitter, whereas the master generates an extra acknowledge related clock pulse.

A slave receiver which is addressed must generate an acknowledge after the reception of each byte. Also a master must generate an acknowledge after the reception of each byte that has been clocked out of the slave transmitter. The device that acknowledges has to pull down the SDA line during the acknowledge clock pulse, so that the SDA line is stable LOW during the HIGH period of the acknowledge related clock pulse; set-up time and hold time must be taken into account.

A master receiver must signal an end of data to the transmitter by not generating an acknowledge on the last byte that has been clocked out of the slave. In this event, the transmitter must leave the data line HIGH to enable the master to generate a STOP condition.

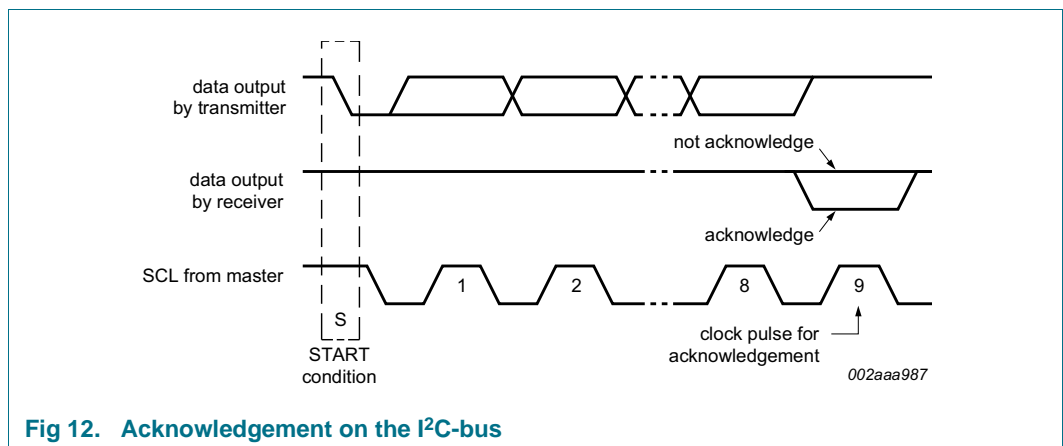
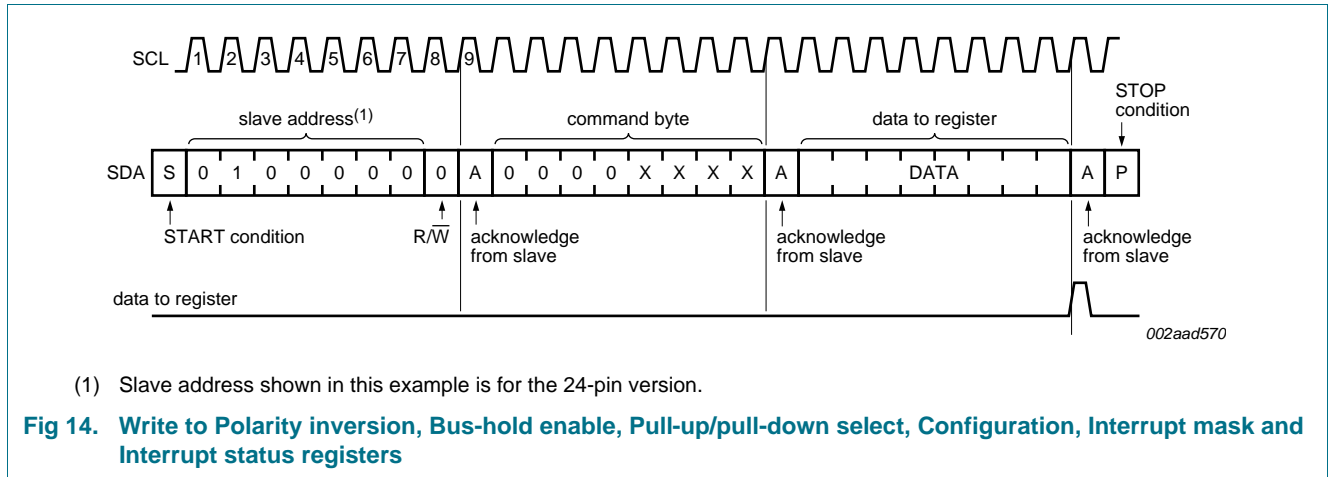
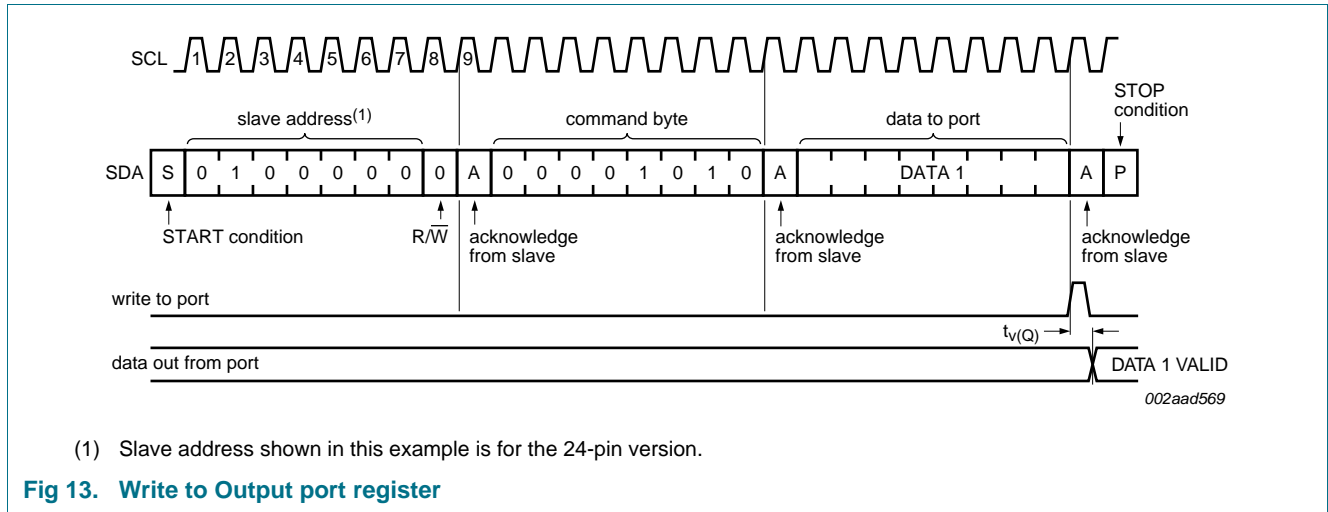

Fig 12. Acknowledgement on the I<sup>2</sup>C-bus

## 9. Bus transactions

Data is transmitted to the PCA9575 registers using 'Write Byte' transfers (see [Figure 13](#) and [Figure 14](#)).

Data is read from the PCA9575 registers using 'Read Byte' transfers (see [Figure 15](#) and [Figure 16](#)).



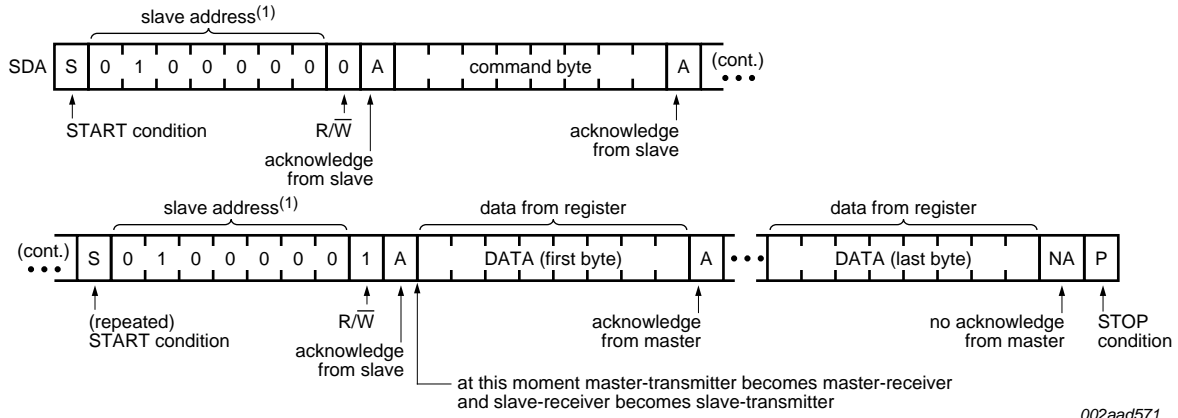

(1) Slave address shown in this example is for the 24-pin version.

**Fig 15. Read from register**

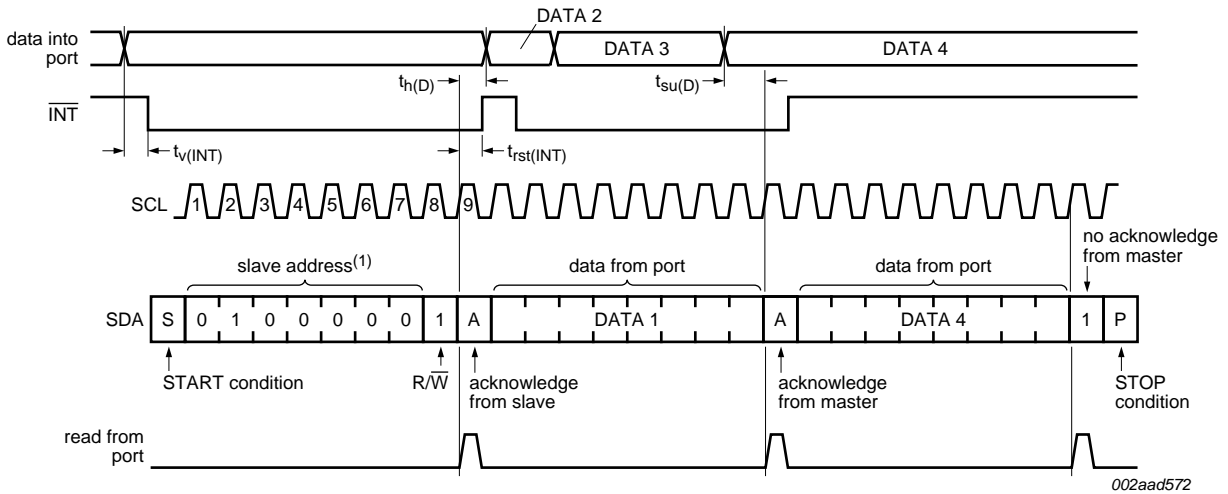

This figure assumes the command byte has previously been programmed with 00h.

Transfer of data can be stopped at any moment by a STOP condition.

(1) Slave address shown in this example is for the 24-pin version.

**Fig 16. Read input port register**

## 10. Application design-in information

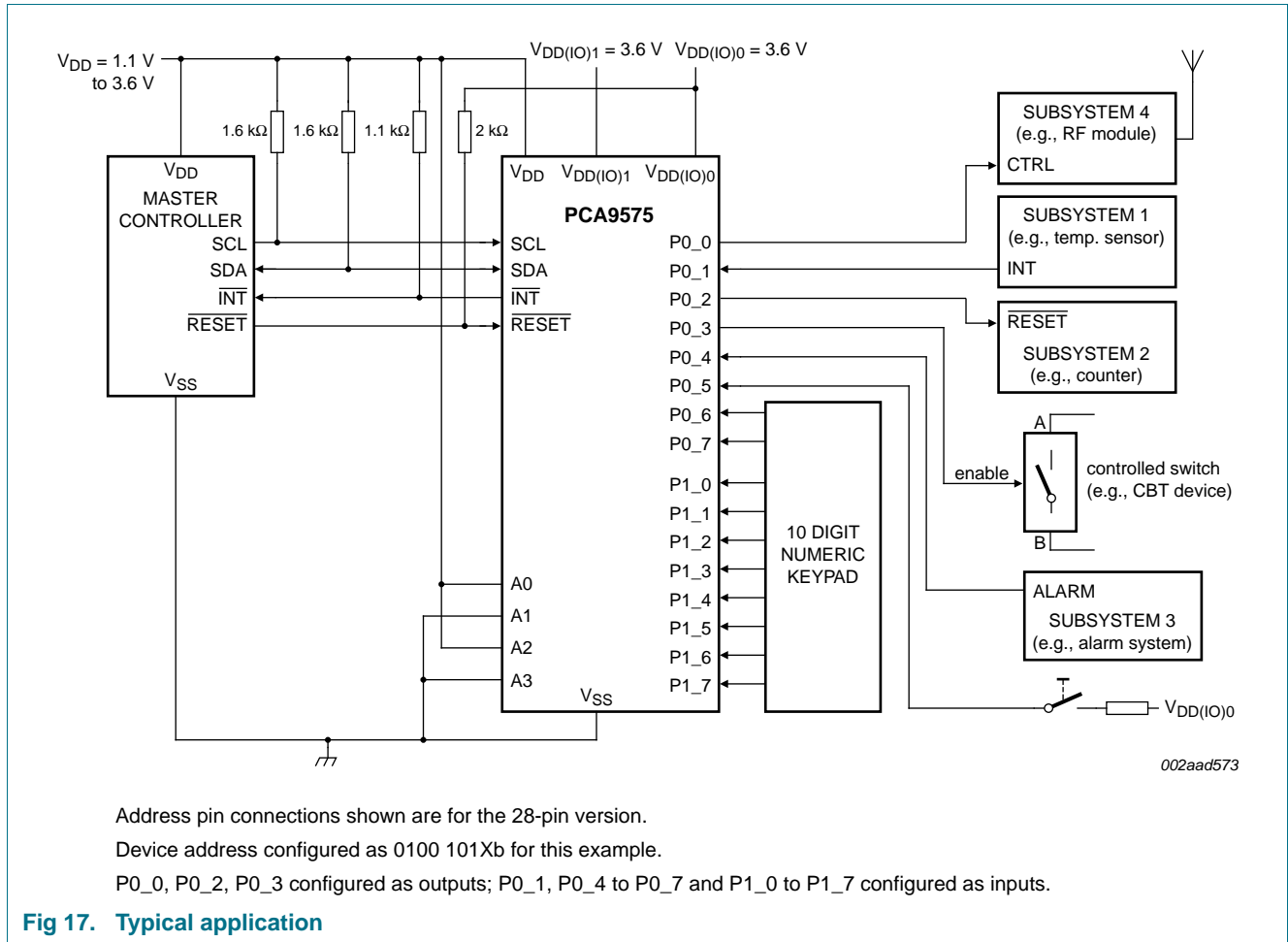

## 11. Limiting values

**Table 21. Limiting values**

*In accordance with the Absolute Maximum Rating System (IEC 60134).*

| Symbol                            | Parameter                     | Conditions | Min                   | Max       | Unit |
|-----------------------------------|-------------------------------|------------|-----------------------|-----------|------|
| V <sub>DD</sub>                   | supply voltage                |            | -0.5                  | +4.0      | V    |
| V <sub>DD</sub> (IO) <sub>0</sub> | input/output supply voltage 0 |            | V <sub>SS</sub> - 0.5 | 4.0 + 0.5 | V    |
| V <sub>DD</sub> (IO) <sub>1</sub> | input/output supply voltage 1 |            | V <sub>SS</sub> - 0.5 | 4.0 + 0.5 | V    |
| I <sub>I/O</sub>                  | input/output current          |            | -                     | ±5        | mA   |
| I <sub>I</sub>                    | input current                 |            | -                     | ±20       | mA   |
| I <sub>DD</sub>                   | supply current                |            | -                     | 90        | mA   |
| I <sub>SS</sub>                   | ground supply current         |            | -                     | 90        | mA   |
| P <sub>tot</sub>                  | total power dissipation       |            | -                     | 75        | mW   |
| T <sub>stg</sub>                  | storage temperature           |            | -65                   | +150      | °C   |
| T <sub>amb</sub>                  | ambient temperature           |            | -40                   | +85       | °C   |



## 12. Static characteristics

**Table 22. Static characteristics**

$V_{DD} = 1.1\text{ V to }3.6\text{ V}$ ;  $V_{DD(I/O)0} = 1.1\text{ V to }3.6\text{ V}$ ;  $V_{DD(I/O)1} = 1.1\text{ V to }3.6\text{ V}$ ;  $V_{SS} = 0\text{ V}$ ;  $T_{amb} = -40\text{ °C to }+85\text{ °C}$ , with HWQFN24 up to  $+105\text{ °C}$ ; unless otherwise specified.

| Symbol                             | Parameter                        | Conditions   | Min               | Typ  | Max                | Unit             |
|------------------------------------|----------------------------------|--|-------------------|------|--------------------|------------------|
| <b>Supplies</b>                    |                                  |  |                   |      |                    |                  |
| $V_{DD}$                           | supply voltage                   |  | 1.1               | -    | 3.6                | V                |
| $V_{DD(I/O)0}$                     | input/output supply voltage 0    |  | 1.1               | -    | 3.6 + 0.5          | V                |
| $V_{DD(I/O)1}$                     | input/output supply voltage 1    |  | 1.1               | -    | 3.6 + 0.5          | V                |
| $I_{DD}$                           | supply current                   | operating mode; $V_{DD} = 3.6\text{ V}$ ;<br>no load; $f_{SCL} = 100\text{ kHz}$ ; I/O = inputs                                      | -                 | 135  | 200                | $\mu\text{A}$    |
| $I_{stbL}$                         | LOW-level standby current        | Standby mode; $V_{DD} = 3.6\text{ V}$ ; no load;<br>$V_I = V_{SS}$ ; $f_{SCL} = 0\text{ kHz}$ ; I/O = inputs                         | -                 | 0.25 | 2 <sup>[1]</sup>   | $\mu\text{A}$    |
| $I_{stbH}$                         | HIGH-level standby current       | Standby mode; $V_{DD} = 3.6\text{ V}$ ; no load;<br>$V_I = V_{DD(I/O)0} = V_{DD(I/O)1}$ ;<br>$f_{SCL} = 0\text{ kHz}$ ; I/O = inputs | -                 | 0.25 | 2 <sup>[1]</sup>   | $\mu\text{A}$    |
| $V_{POR}$                          | power-on reset voltage           | no load; $V_I = V_{DD}$ or $V_{SS}$ (rising $V_{DD}$ )   | -                 | 0.7  | 1.0                | V                |
| <b>Input SCL; input/output SDA</b> |                                  |  |                   |      |                    |                  |
| $V_{IL}$                           | LOW-level input voltage          |  | -0.5              | -    | +0.3 $V_{DD}$      | V                |
| $V_{IH}$                           | HIGH-level input voltage         |  | 0.7 $V_{DD}$      | -    | 3.6                | V                |
| $I_{OL}$                           | LOW-level output current         | $V_{OL} = 0.2\text{ V}$ ; $V_{DD} = 1.1\text{ V}$  | 1                 | -    | -                  | $\text{mA}$      |
|                                    |                                  | $V_{OL} = 0.4\text{ V}$ ; $V_{DD} = 2.3\text{ V}$  | 3                 | -    | -                  | $\text{mA}$      |
| $I_L$                              | leakage current                  | $V_I = V_{DD}$ or $V_{SS}$   | -1                | -    | +1                 | $\mu\text{A}$    |
| $C_i$                              | input capacitance                | $V_I = V_{SS}$   | -                 | 6    | 10                 | $\text{pF}$      |
| <b>I/Os</b>                        |                                  |  |                   |      |                    |                  |
| $V_{IL}$                           | LOW-level input voltage          |  | -0.5              | -    | +0.3 $V_{DD(I/O)}$ | V                |
| $V_{IH}$                           | HIGH-level input voltage         |  | 0.7 $V_{DD(I/O)}$ | -    | 3.6                | V                |
| $I_{OL}$                           | LOW-level output current         | $V_{OL} = 0.2\text{ V}$ ; $V_{DD(I/O)0} = 1.1\text{ V}$ ;<br>$V_{DD(I/O)1} = 1.1\text{ V}$   | 1                 | -    | -                  | $\text{mA}$      |
|                                    |                                  | $V_{OL} = 0.5\text{ V}$ ; $V_{DD(I/O)0} = 3.6\text{ V}$ ;<br>$V_{DD(I/O)1} = 3.6\text{ V}$   | 2                 | 3    | -                  | $\text{mA}$      |
| $V_{OH}$                           | HIGH-level output voltage        | $I_{OH} = -1\text{ mA}$ ; $V_{DD(I/O)0} = 1.1\text{ V}$ ;<br>$V_{DD(I/O)1} = 1.1\text{ V}$   | 0.8               | -    | -                  | V                |
| $R_{pu(int)}$                      | internal pull-up resistance      |  | 50                | 100  | 150                | $\text{k}\Omega$ |
| $I_{LIH}$                          | HIGH-level input leakage current | $V_{DD(I/O)0} = 3.6\text{ V}$ ; $V_{DD(I/O)1} = 3.6\text{ V}$ ;<br>$V_I = V_{DD(I/O)0}$ ; $V_I = V_{DD(I/O)1}$                       | -                 | -    | 1                  | $\mu\text{A}$    |
| $I_H$                              | holding current                  | $V_I = 0.3\text{ V}$ ; $V_{DD(I/O)0} = 1.1\text{ V}$ ;<br>$V_{DD(I/O)1} = 1.1\text{ V}$ ; $V_{DD} = 3.6\text{ V}$                    | 10                | -    | -                  | $\mu\text{A}$    |
|                                    |                                  | $V_I = 0.8\text{ V}$ ; $V_{DD(I/O)0} = 1.1\text{ V}$ ;<br>$V_{DD(I/O)1} = 1.1\text{ V}$ ; $V_{DD} = 3.6\text{ V}$                    | -10               | -    | -                  | $\mu\text{A}$    |
| $I_{LIL}$                          | LOW-level input leakage current  | $V_{DD(I/O)0} = 3.6\text{ V}$ ; $V_{DD(I/O)1} = 3.6\text{ V}$ ;<br>$V_I = V_{SS}$  | -                 | -    | -1                 | $\mu\text{A}$    |
| $C_i$                              | input capacitance                |  | -                 | 3.7  | 5                  | $\text{pF}$      |
| $C_o$                              | output capacitance               |  | -                 | 3.7  | 5                  | $\text{pF}$      |

**Table 22. Static characteristics ...continued**

$V_{DD} = 1.1 \text{ V to } 3.6 \text{ V}$ ;  $V_{DD(I/O)0} = 1.1 \text{ V to } 3.6 \text{ V}$ ;  $V_{DD(I/O)1} = 1.1 \text{ V to } 3.6 \text{ V}$ ;  $V_{SS} = 0 \text{ V}$ ;  $T_{amb} = -40 \text{ }^\circ\text{C to } +85 \text{ }^\circ\text{C}$ , with HWQFN24 up to  $+105 \text{ }^\circ\text{C}$ ; unless otherwise specified.

| Symbol                                   | Parameter                | Conditions  | Min            | Typ | Max  | Unit          |
|--|--------------------------|---|----------------|-----|------|---------------|
| <b>Interrupt INT</b>                     |                          |   |                |     |      |               |
| $I_{OL}$                                 | LOW-level output current | $V_{OL} = 0.4 \text{ V}$ ; $V_{DD} = 1.1 \text{ V}$ | 3              | -   | -    | mA            |
| <b>Select inputs (reset and address)</b> |                          |   |                |     |      |               |
| $V_{IL}$                                 | LOW-level input voltage  |   | -              | -   | +0.2 | V             |
| $V_{IH}$                                 | HIGH-level input voltage |   | $V_{DD} - 0.2$ | -   | -    | V             |
| $I_{LI}$                                 | input leakage current    |   | -1             | -   | +1   | $\mu\text{A}$ |
| $C_i$                                    | input capacitance        |   | -              | 2   | 4    | pF            |

[1] For HWSON24 package operating from  $+85 \text{ }^\circ\text{C}$  to  $105 \text{ }^\circ\text{C}$  the maximum value is  $3 \mu\text{A}$

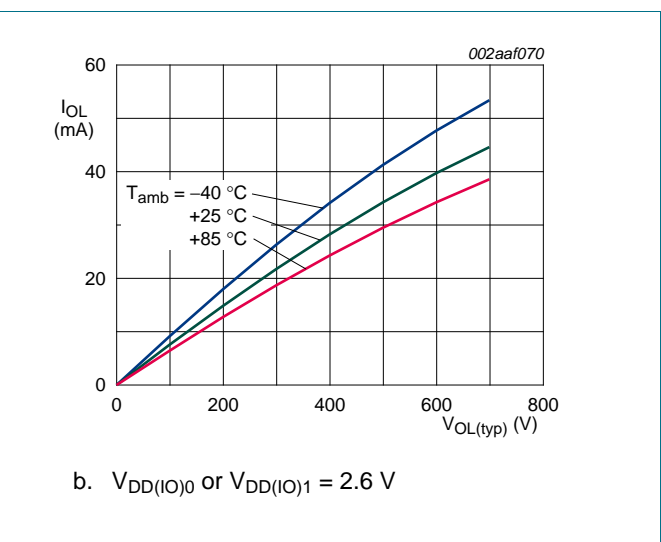
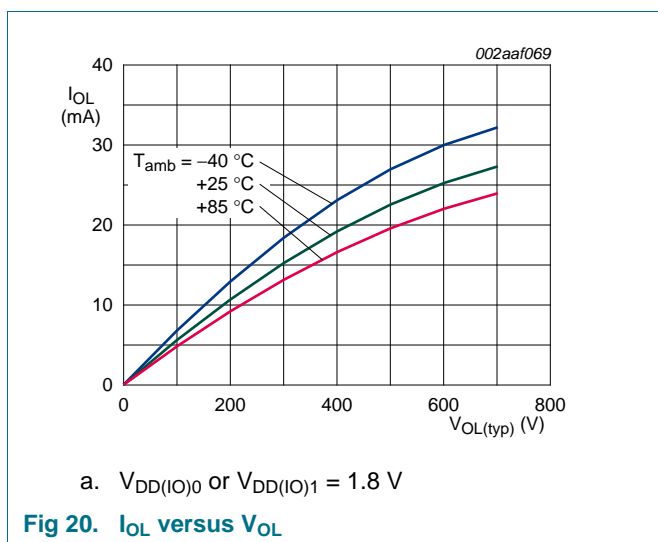
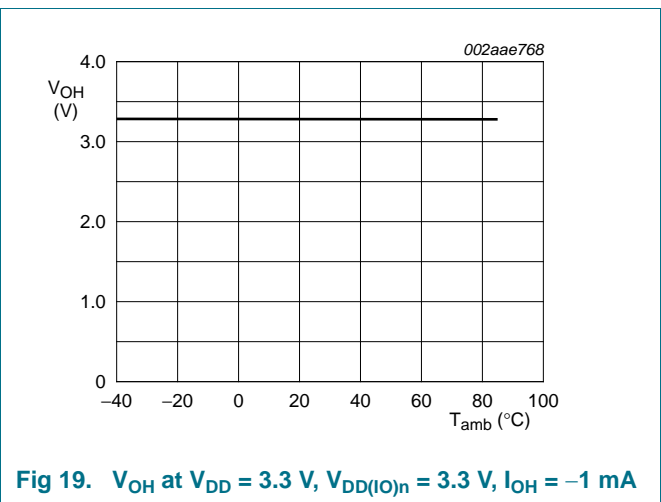
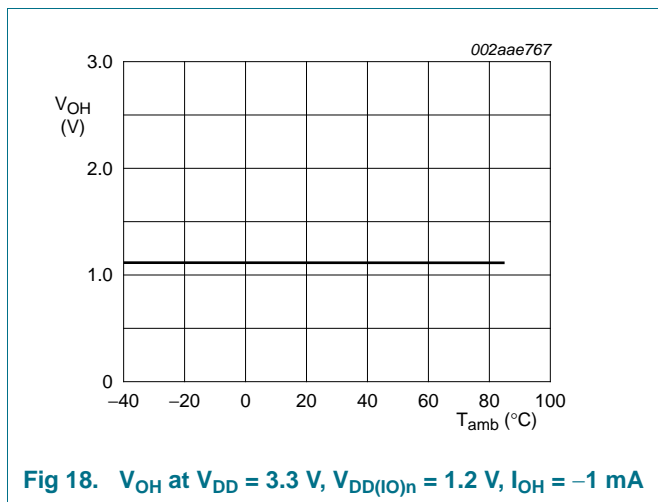

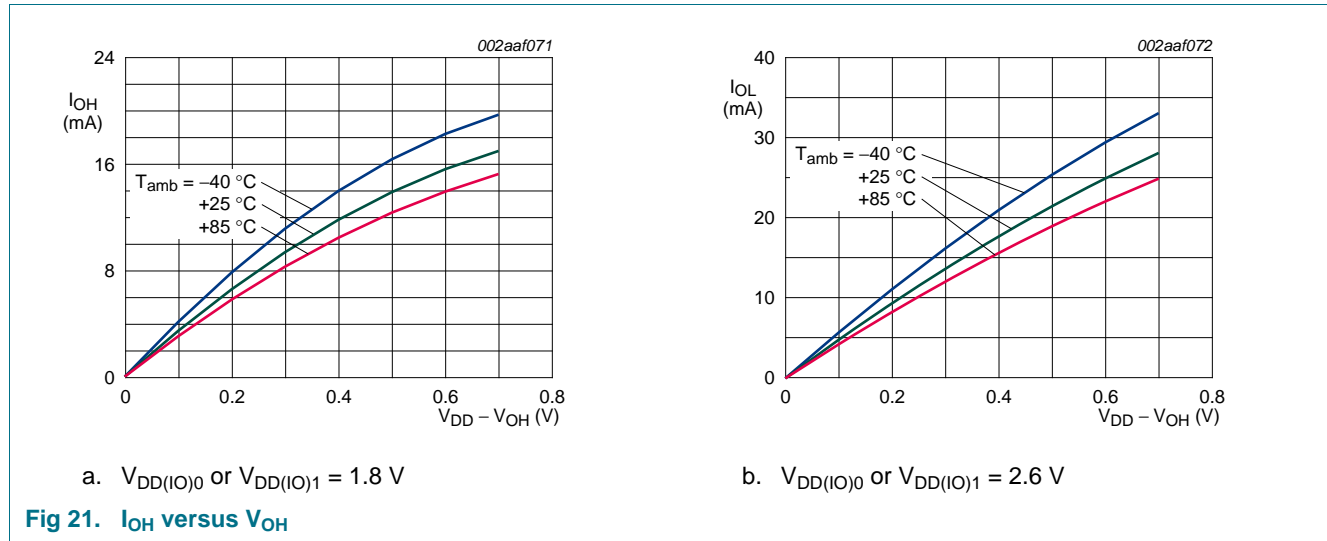

### 13. Dynamic characteristics

**Table 23. Dynamic characteristics**

$V_{DD} = 1.1\text{ V to }3.6\text{ V}$ ;  $V_{DD(IO)0} = 1.1\text{ V to }3.6\text{ V}$ ;  $V_{DD(IO)1} = 1.1\text{ V to }3.6\text{ V}$ ;  $V_{SS} = 0\text{ V}$ ;  $T_{amb} = -40\text{ }^{\circ}\text{C to }+85\text{ }^{\circ}\text{C}$ , with HWQFN24 up to  $+105\text{ }^{\circ}\text{C}$ ; unless otherwise specified.

| Symbol       | Parameter   | Conditions | Standard-mode I <sup>2</sup> C-bus |      | Fast-mode I <sup>2</sup> C-bus |     | Unit          |
|--------------|---|------------|------------------------------------|------|--------------------------------|-----|---------------|
|              |   |            | Min                                | Max  | Min                            | Max |               |
| $f_{SCL}$    | SCL clock frequency   |            | 0                                  | 100  | 0                              | 400 | kHz           |
| $t_{BUF}$    | bus free time between a STOP and START condition                  |            | 4.7                                | -    | 1.3                            | -   | $\mu\text{s}$ |
| $t_{HD;STA}$ | hold time (repeated) START condition                              |            | 4.0                                | -    | 0.6                            | -   | $\mu\text{s}$ |
| $t_{SU;STA}$ | set-up time for a repeated START condition                        |            | 4.7                                | -    | 0.6                            | -   | $\mu\text{s}$ |
| $t_{SU;STO}$ | set-up time for STOP condition                                    |            | 4.0                                | -    | 0.6                            | -   | $\mu\text{s}$ |
| $t_{VD;ACK}$ | data valid acknowledge time                                       | [1]        | 0.3                                | 3.45 | 0.1                            | 0.9 | $\mu\text{s}$ |
| $t_{HD;DAT}$ | data hold time  |            | 0                                  | -    | 0                              | -   | ns            |
| $t_{VD;DAT}$ | data valid time   | [2]        | 300                                | -    | 50                             | -   | ns            |
| $t_{SU;DAT}$ | data set-up time  |            | 250                                | -    | 100                            | -   | ns            |
| $t_{LOW}$    | LOW period of the SCL clock                                       |            | 4.7                                | -    | 1.3                            | -   | $\mu\text{s}$ |
| $t_{HIGH}$   | HIGH period of the SCL clock                                      |            | 4.0                                | -    | 0.6                            | -   | $\mu\text{s}$ |
| $t_f$        | fall time of both SDA and SCL signals                             |            | -                                  | 300  | $20 + 0.1C_p$ [3]              | 300 | ns            |
| $t_r$        | rise time of both SDA and SCL signals                             |            | -                                  | 1000 | $20 + 0.1C_p$ [3]              | 300 | ns            |
| $t_{SP}$     | pulse width of spikes that must be suppressed by the input filter |            | -                                  | 50   | -                              | 50  | ns            |

**Table 23. Dynamic characteristics ...continued**

$V_{DD} = 1.1\text{ V to }3.6\text{ V}$ ;  $V_{DD(1O)0} = 1.1\text{ V to }3.6\text{ V}$ ;  $V_{DD(1O)1} = 1.1\text{ V to }3.6\text{ V}$ ;  $V_{SS} = 0\text{ V}$ ;  $T_{amb} = -40\text{ }^{\circ}\text{C to }+85\text{ }^{\circ}\text{C}$ , with HWQFN24 up to  $+105\text{ }^{\circ}\text{C}$ ; unless otherwise specified.

| Symbol                  | Parameter                                 | Conditions   | Standard-mode I <sup>2</sup> C-bus |     | Fast-mode I <sup>2</sup> C-bus |     | Unit          |
|-------------------------|---|--|------------------------------------|-----|--------------------------------|-----|---------------|
|                         |   |  | Min                                | Max | Min                            | Max |               |
| <b>Port timing</b>      |   |  |                                    |     |                                |     |               |
| $t_{V(Q)}$              | data output valid time                    | $V_{DD(1O)0}, V_{DD(1O)1} = V_{DD} = 1.1\text{ V}$                 | -                                  | 350 | -                              | 350 | ns            |
|                         |   | $V_{DD(1O)0}, V_{DD(1O)1} = V_{DD} = 2.3\text{ V to }3.6\text{ V}$ | -                                  | 300 | -                              | 300 | ns            |
| $t_{su(D)}$             | data input set-up time                    |  | 150                                | -   | 150                            | -   | ns            |
| $t_{h(D)}$              | data input hold time                      |  | 1                                  | -   | 1                              | -   | $\mu\text{s}$ |
| <b>Interrupt timing</b> |   |  |                                    |     |                                |     |               |
| $t_{V(INT)}$            | valid time on pin $\overline{\text{INT}}$ |  | -                                  | 4   | -                              | 4   | $\mu\text{s}$ |
| $t_{rst(INT)}$          | reset time on pin $\overline{\text{INT}}$ |  | -                                  | 4   | -                              | 4   | $\mu\text{s}$ |
| <b>Reset</b>            |   |  |                                    |     |                                |     |               |
| $t_{w(rst)}$            | reset pulse width                         | $V_{DD(1O)0}, V_{DD(1O)1} = V_{DD} = 1.1\text{ V}$                 | 8                                  | -   | 8                              | -   | ns            |
|                         |   | $V_{DD(1O)0}, V_{DD(1O)1} = V_{DD} = 2.3\text{ V to }3.6\text{ V}$ | 4                                  | -   | 4                              | -   | ns            |
| $t_{rec(rst)}$          | reset recovery time                       |  | 0                                  | -   | 0                              | -   | ns            |
| $t_{rst(SDA)}$          | SDA reset time                            | <a href="#">Figure 23</a>  | -                                  | 400 | -                              | 400 | ns            |
| $t_{rst(GPIO)}$         | GPIO reset time                           | <a href="#">Figure 23</a>  | -                                  | 400 | -                              | 400 | ns            |

- [1]  $t_{VD;ACK}$  = time for acknowledgment signal from SCL LOW to SDA (out) LOW.
- [2]  $t_{VD;DAT}$  = minimum time for SDA data out to be valid following SCL LOW.
- [3]  $C_b$  = total capacitance of one bus line in pF.

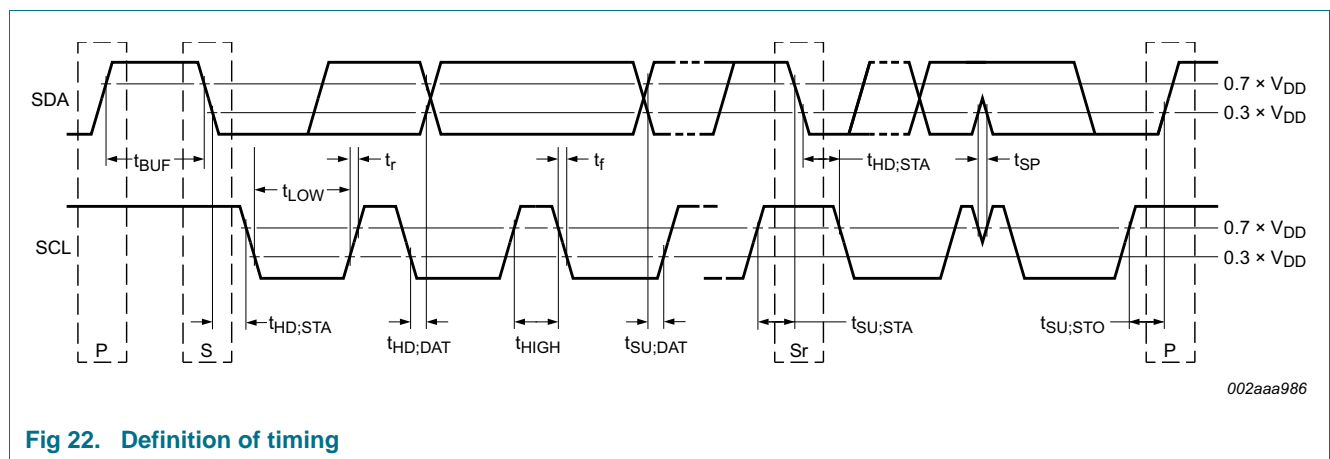

**Fig 22. Definition of timing**

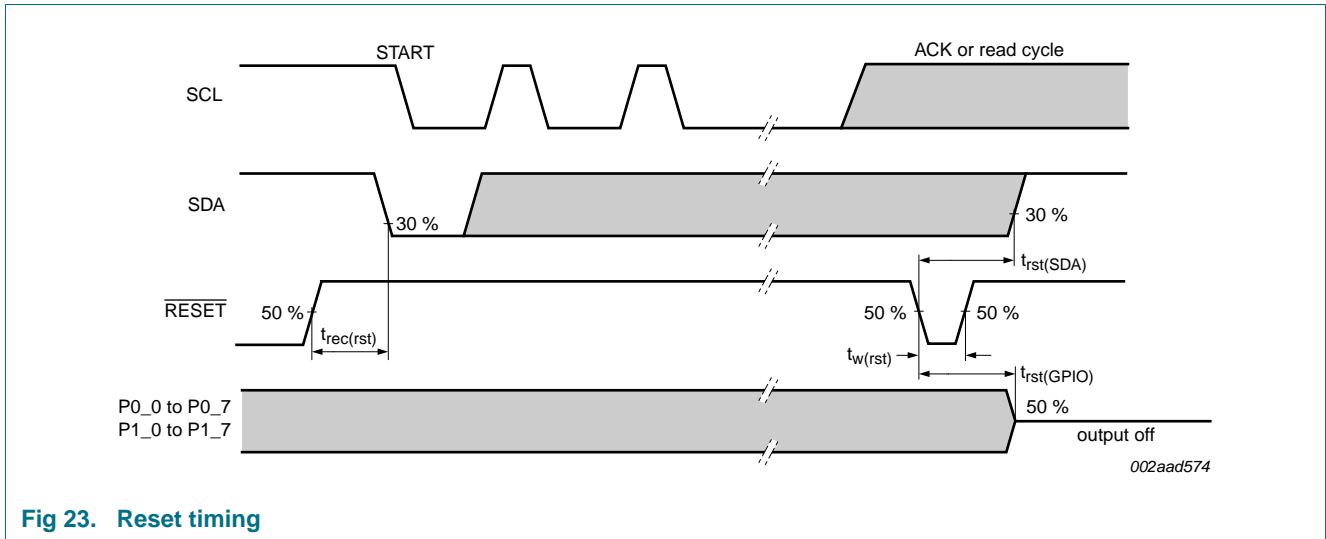

Fig 23. Reset timing

## 14. Test information

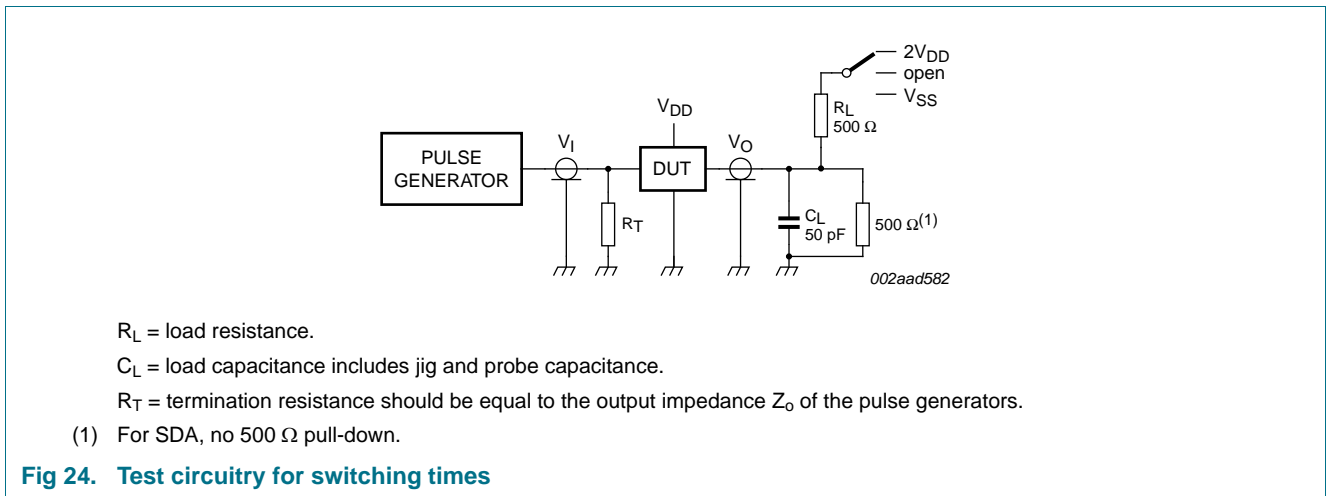

Fig 24. Test circuitry for switching times

### 15. Package outline

TSSOP24: plastic thin shrink small outline package; 24 leads; body width 4.4 mm

SOT355-1

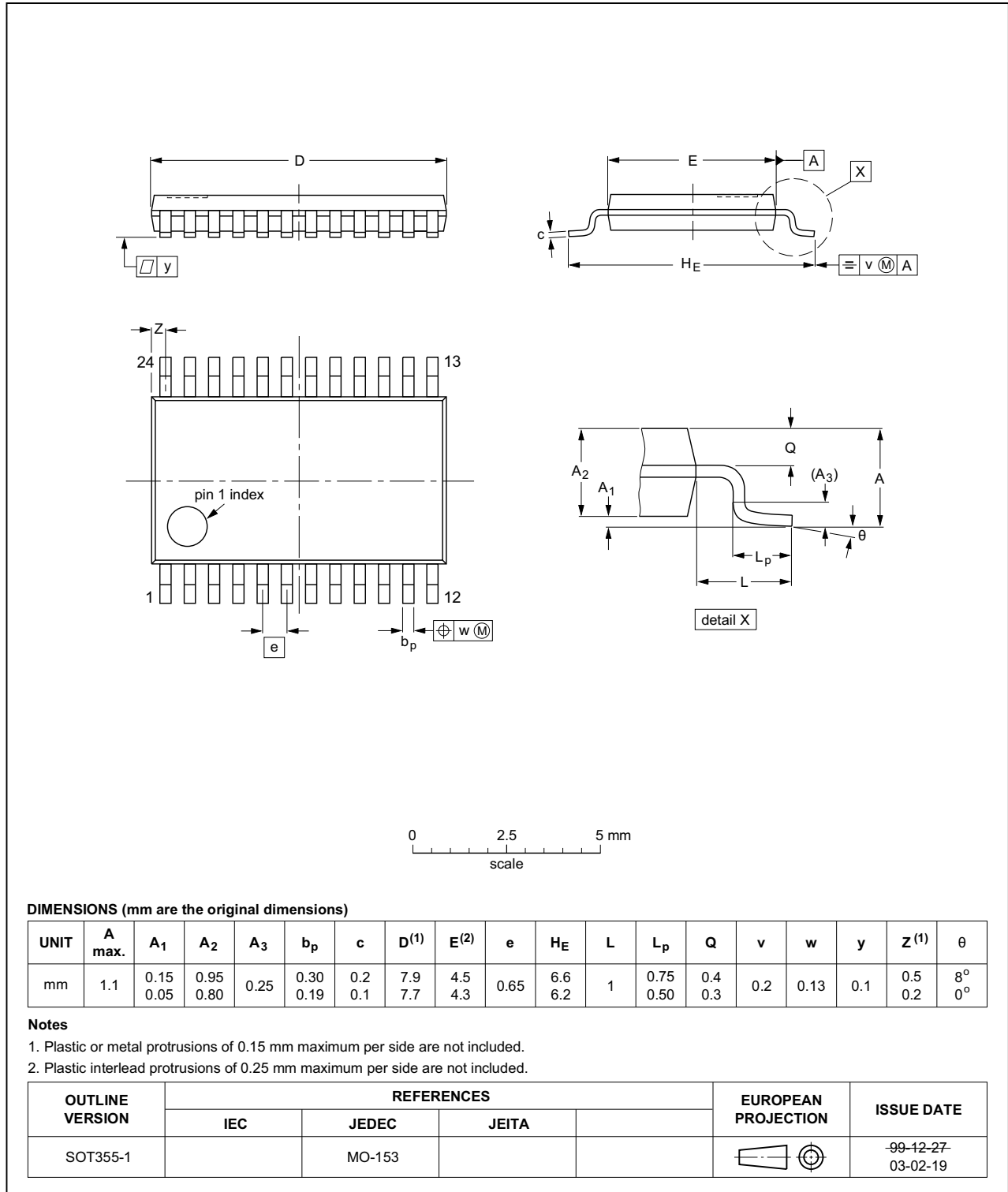

Fig 25. Package outline SOT355-1 (TSSOP24)

TSSOP28: plastic thin shrink small outline package; 28 leads; body width 4.4 mm

SOT361-1

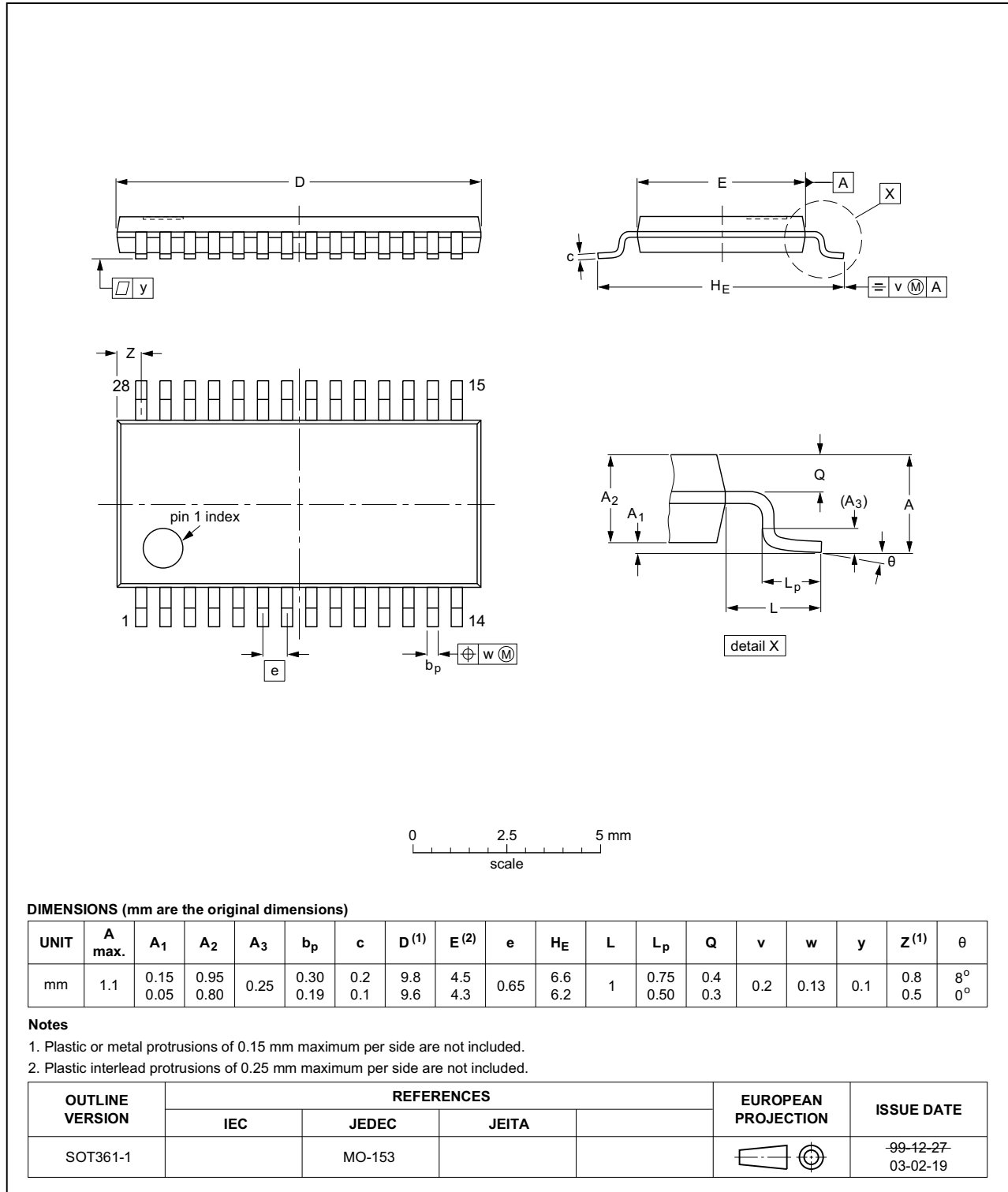

Fig 26. Package outline SOT361-1 (TSSOP28)

HWQFN24: plastic thermal enhanced very very thin quad flat package; no leads; 24 terminals; body 4 x 4 x 0.75 mm

SOT994-1

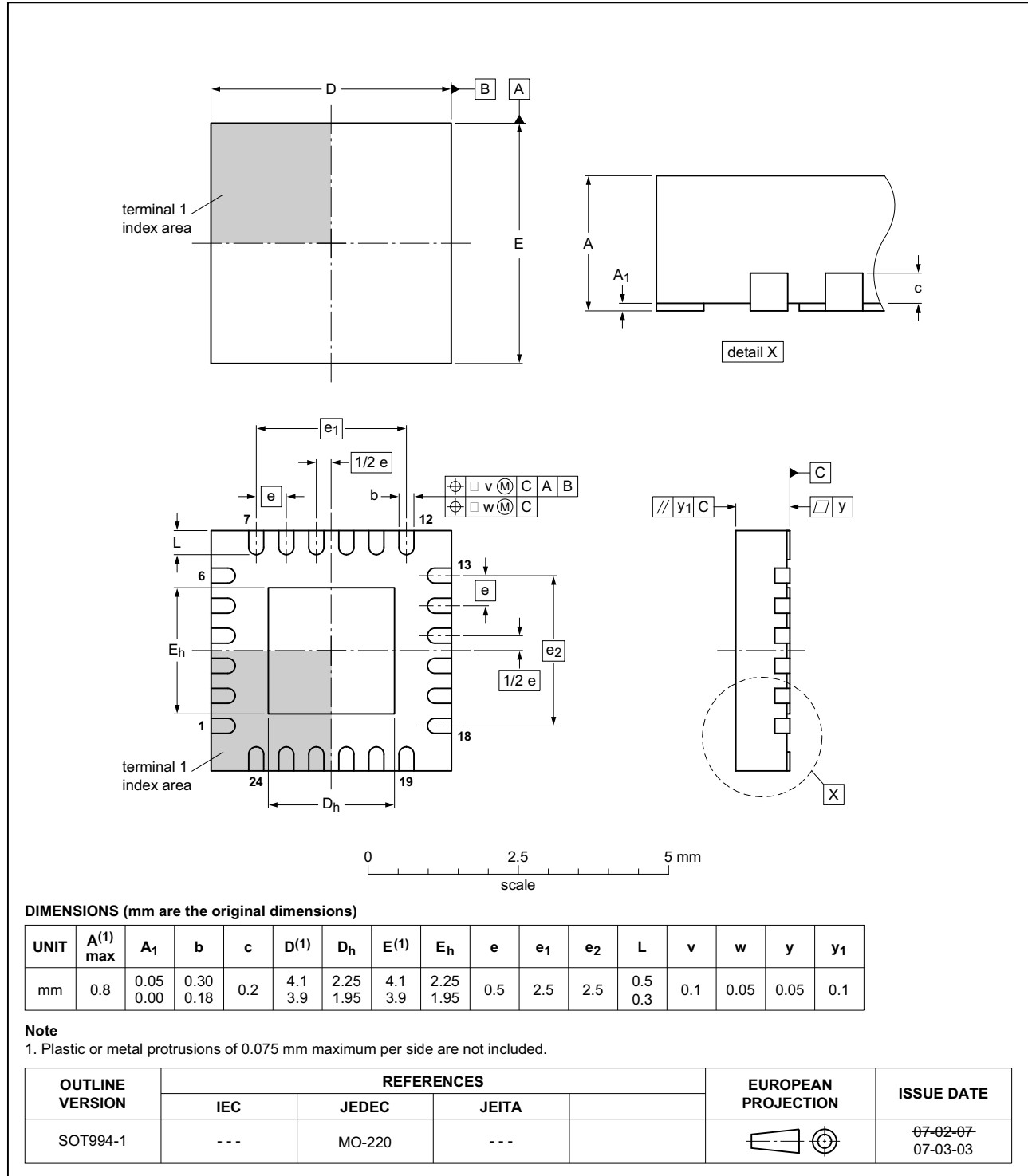

Fig 27. Package outline SOT994-1 (HWQFN24)



## 16. Handling information

---

All input and output pins are protected against ElectroStatic Discharge (ESD) under normal handling. When handling ensure that the appropriate precautions are taken as described in *JESD625-A* or equivalent standards.

## 17. Soldering of SMD packages

---

This text provides a very brief insight into a complex technology. A more in-depth account of soldering ICs can be found in Application Note *AN10365 "Surface mount reflow soldering description"*.

### 17.1 Introduction to soldering

Soldering is one of the most common methods through which packages are attached to Printed Circuit Boards (PCBs), to form electrical circuits. The soldered joint provides both the mechanical and the electrical connection. There is no single soldering method that is ideal for all IC packages. Wave soldering is often preferred when through-hole and Surface Mount Devices (SMDs) are mixed on one printed wiring board; however, it is not suitable for fine pitch SMDs. Reflow soldering is ideal for the small pitches and high densities that come with increased miniaturization.

### 17.2 Wave and reflow soldering

Wave soldering is a joining technology in which the joints are made by solder coming from a standing wave of liquid solder. The wave soldering process is suitable for the following:

- Through-hole components
- Leaded or leadless SMDs, which are glued to the surface of the printed circuit board

Not all SMDs can be wave soldered. Packages with solder balls, and some leadless packages which have solder lands underneath the body, cannot be wave soldered. Also, leaded SMDs with leads having a pitch smaller than ~0.6 mm cannot be wave soldered, due to an increased probability of bridging.

The reflow soldering process involves applying solder paste to a board, followed by component placement and exposure to a temperature profile. Leaded packages, packages with solder balls, and leadless packages are all reflow solderable.

Key characteristics in both wave and reflow soldering are:

- Board specifications, including the board finish, solder masks and vias
- Package footprints, including solder thieves and orientation
- The moisture sensitivity level of the packages
- Package placement
- Inspection and repair
- Lead-free soldering versus SnPb soldering

### 17.3 Wave soldering

Key characteristics in wave soldering are:

- Process issues, such as application of adhesive and flux, clinching of leads, board transport, the solder wave parameters, and the time during which components are exposed to the wave
- Solder bath specifications, including temperature and impurities

### 17.4 Reflow soldering

Key characteristics in reflow soldering are:

- Lead-free versus SnPb soldering; note that a lead-free reflow process usually leads to higher minimum peak temperatures (see [Figure 28](#)) than a SnPb process, thus reducing the process window
- Solder paste printing issues including smearing, release, and adjusting the process window for a mix of large and small components on one board
- Reflow temperature profile; this profile includes preheat, reflow (in which the board is heated to the peak temperature) and cooling down. It is imperative that the peak temperature is high enough for the solder to make reliable solder joints (a solder paste characteristic). In addition, the peak temperature must be low enough that the packages and/or boards are not damaged. The peak temperature of the package depends on package thickness and volume and is classified in accordance with [Table 24](#) and [25](#)

**Table 24. SnPb eutectic process (from J-STD-020D)**

| Package thickness (mm) | Package reflow temperature (°C) |       |
|------------------------|---------------------------------|-------|
|                        | Volume (mm <sup>3</sup> )       |       |
|                        | < 350                           | ≥ 350 |
| < 2.5                  | 235                             | 220   |
| ≥ 2.5                  | 220                             | 220   |

**Table 25. Lead-free process (from J-STD-020D)**

| Package thickness (mm) | Package reflow temperature (°C) |             |        |
|------------------------|---------------------------------|-------------|--------|
|                        | Volume (mm <sup>3</sup> )       |             |        |
|                        | < 350                           | 350 to 2000 | > 2000 |
| < 1.6                  | 260                             | 260         | 260    |
| 1.6 to 2.5             | 260                             | 250         | 245    |
| > 2.5                  | 250                             | 245         | 245    |

Moisture sensitivity precautions, as indicated on the packing, must be respected at all times.

Studies have shown that small packages reach higher temperatures during reflow soldering, see [Figure 28](#).

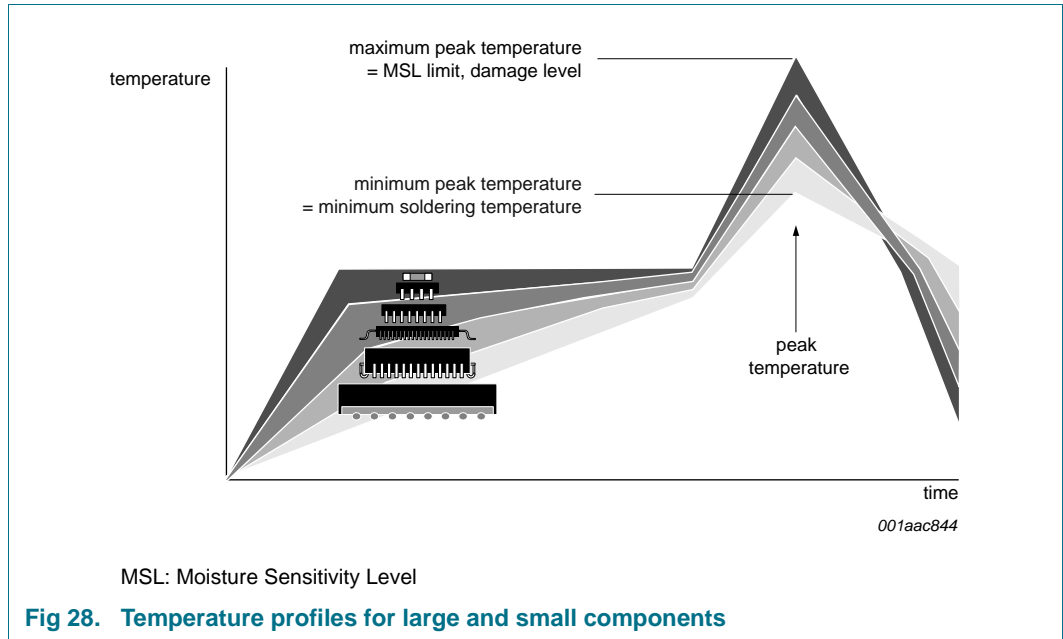

For further information on temperature profiles, refer to Application Note AN10365 “Surface mount reflow soldering description”.

### 18. Soldering: PCB footprints

Footprint information for reflow soldering of TSSOP24 package

SOT355-1

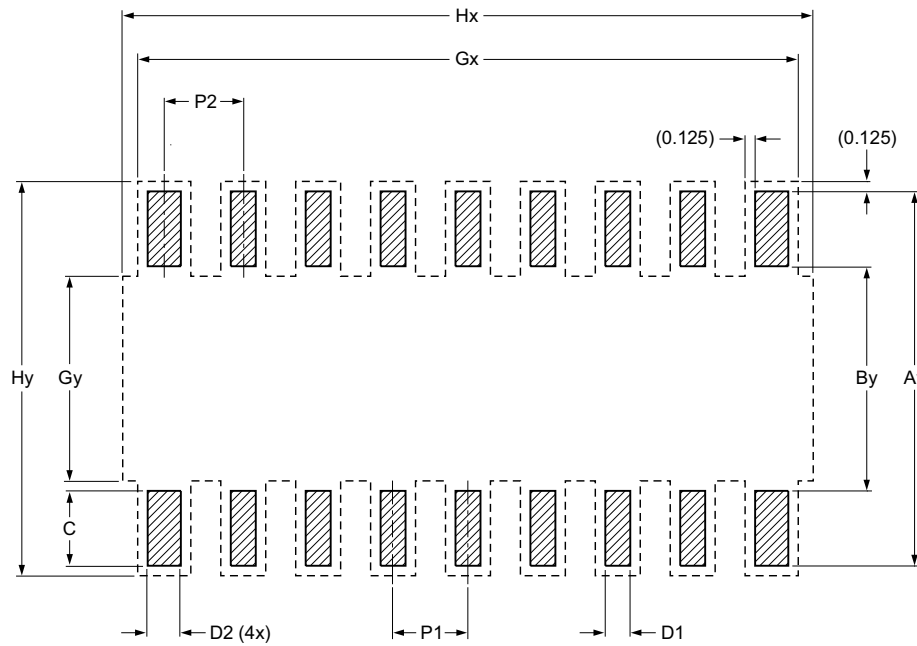

Generic footprint pattern  
Refer to the package outline drawing for actual layout

 solder land  
- - - - occupied area

DIMENSIONS in mm

| P1    | P2    | Ay    | By    | C     | D1    | D2    | Gx    | Gy    | Hx    | Hy    |
|-------|-------|-------|-------|-------|-------|-------|-------|-------|-------|-------|
| 0.650 | 0.750 | 7.200 | 4.500 | 1.350 | 0.400 | 0.600 | 8.200 | 5.300 | 8.600 | 7.450 |

sot355-1\_fr

Fig 29. PCB footprint for SOT355-1 (TSSOP24); reflow soldering

Footprint information for reflow soldering of TSSOP28 package

SOT361-1

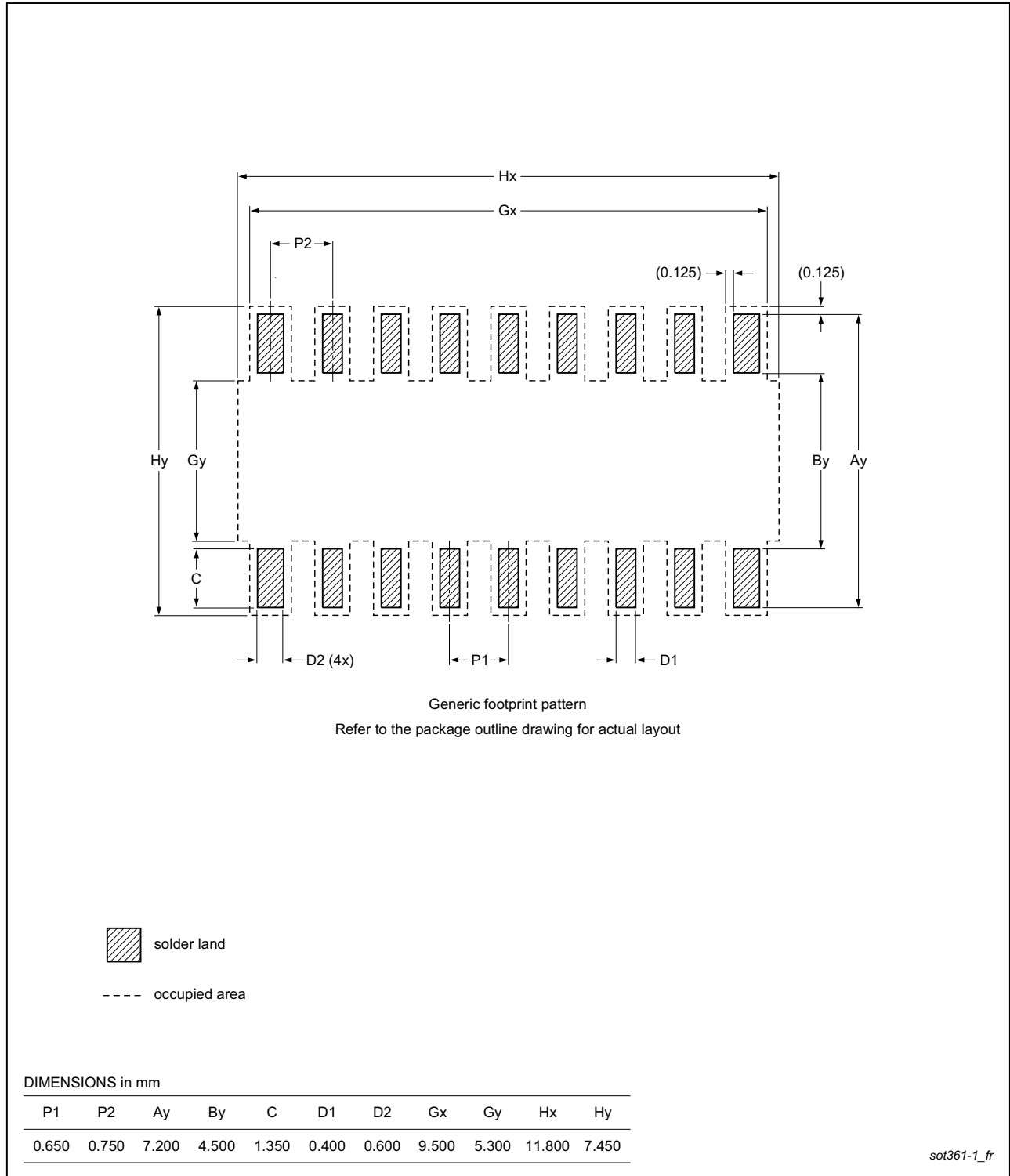
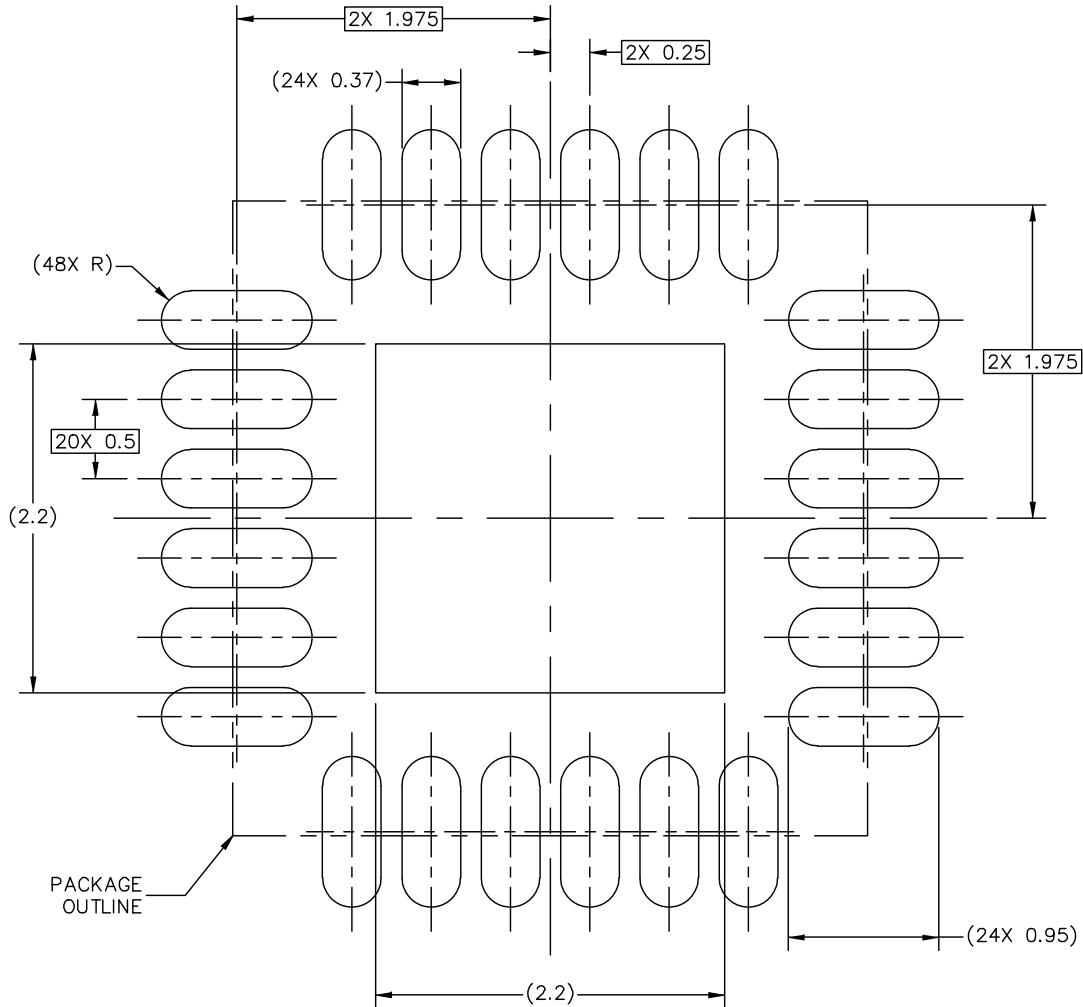

Fig 30. PCB footprint for SOT361-1 (TSSOP28); reflow soldering

H-PQFN-24 I/O  
4 X 4 X 0.75 PKG, 0.5 PITCH

SOT994-1



PCB DESIGN GUIDELINES – SOLDER MASK OPENING PATTERN

THIS SHEET SERVES ONLY AS A GUIDELINE TO HELP DEVELOP A USER SPECIFIC SOLUTION. DEVELOPMENT EFFORT WILL STILL BE REQUIRED BY END USERS TO OPTIMIZE PCB MOUNTING PROCESSES AND BOARD DESIGN IN ORDER TO MEET INDIVIDUAL/SPECIFIC REQUIREMENTS.

© NXP B.V. ALL RIGHTS RESERVED

DATE: 20 SEP 2019

|  |                     |  |  |  |
|--|---------------------|--|--|--|
| MECHANICAL OUTLINE<br>PRINT VERSION NOT TO SCALE | STANDARD:<br>MO-220 |  |  |  |
|--|---------------------|--|--|--|

Fig 31. PCB footprint for SOT994-1 (HWQFN24); reflow soldering (1 of 3)

H-PQFN-24 I/O  
4 X 4 X 0.75 PKG, 0.5 PITCH

SOT994-1

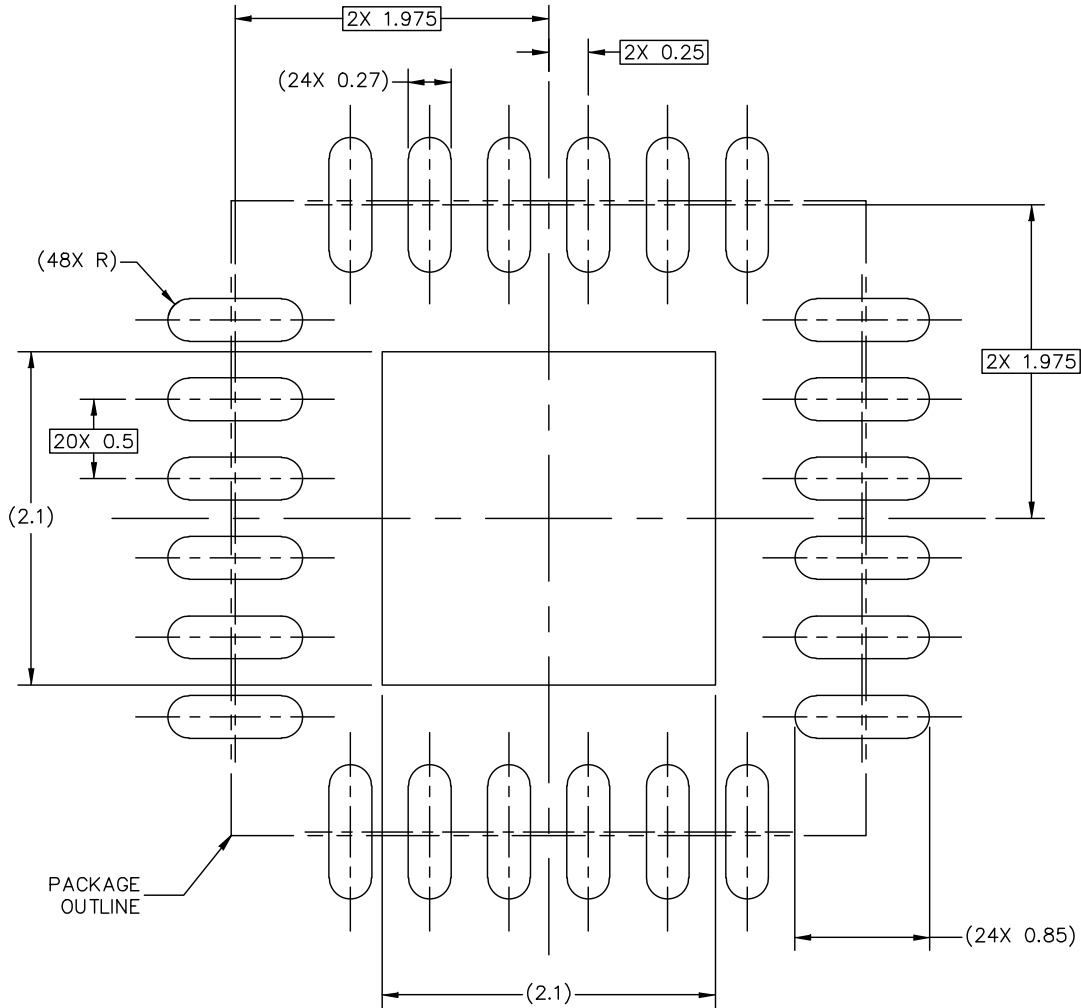

PCB DESIGN GUIDELINES – I/O PADS AND SOLDERABLE AREA

THIS SHEET SERVES ONLY AS A GUIDELINE TO HELP DEVELOP A USER SPECIFIC SOLUTION. DEVELOPMENT EFFORT WILL STILL BE REQUIRED BY END USERS TO OPTIMIZE PCB MOUNTING PROCESSES AND BOARD DESIGN IN ORDER TO MEET INDIVIDUAL/SPECIFIC REQUIREMENTS.

© NXP B.V. ALL RIGHTS RESERVED

DATE: 20 SEP 2019

|  |                     |  |  |  |
|--|---------------------|--|--|--|
| MECHANICAL OUTLINE<br>PRINT VERSION NOT TO SCALE | STANDARD:<br>MO-220 |  |  |  |
|--|---------------------|--|--|--|

Fig 32. PCB footprint for SOT994-1 (HWQFN24); reflow soldering (2 of 3)

H-PQFN-24 I/O  
4 X 4 X 0.75 PKG, 0.5 PITCH

SOT994-1

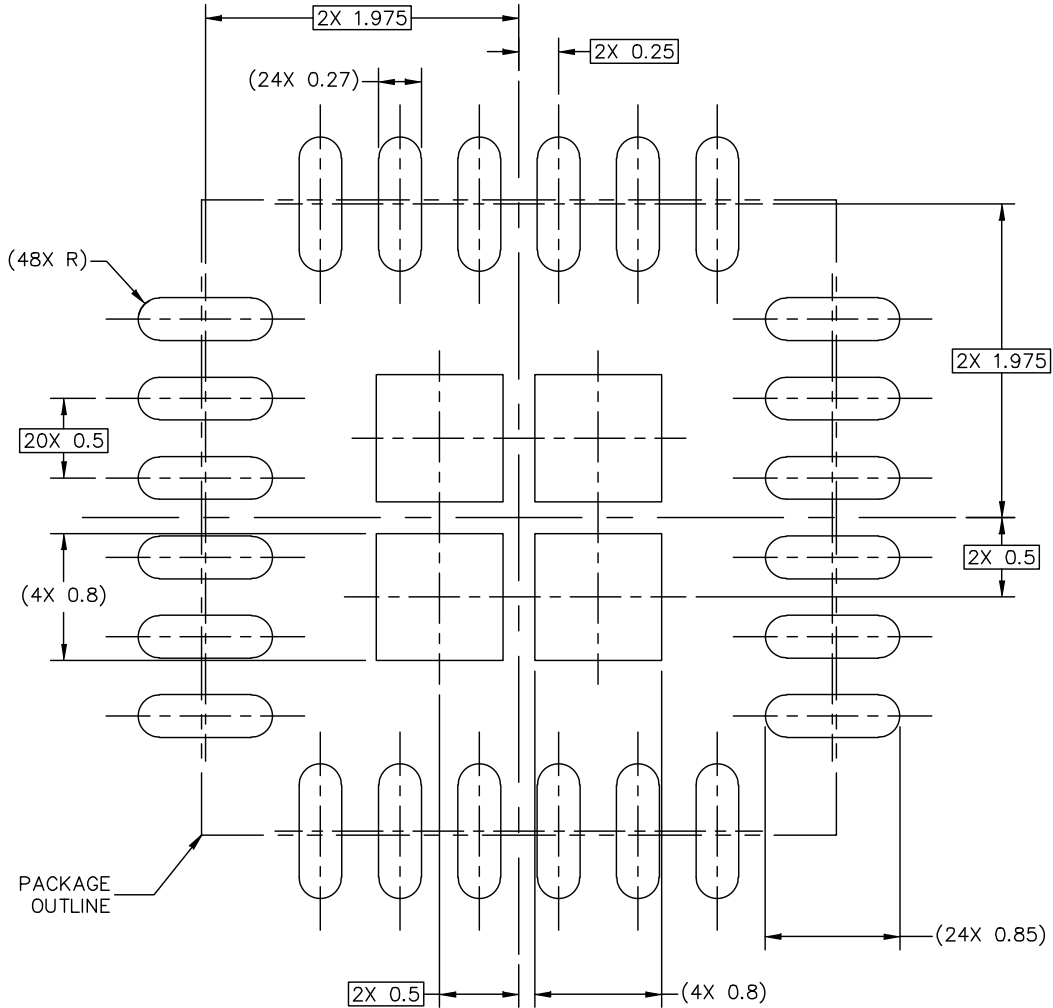

RECOMMENDED STENCIL THICKNESS 0.125

PCB DESIGN GUIDELINES – SOLDER PASTE STENCIL

THIS SHEET SERVES ONLY AS A GUIDELINE TO HELP DEVELOP A USER SPECIFIC SOLUTION. DEVELOPMENT EFFORT WILL STILL BE REQUIRED BY END USERS TO OPTIMIZE PCB MOUNTING PROCESSES AND BOARD DESIGN IN ORDER TO MEET INDIVIDUAL/SPECIFIC REQUIREMENTS.

© NXP B.V. ALL RIGHTS RESERVED

DATE: 20 SEP 2019

|  |                     |  |  |
|--|---------------------|--|--|
| MECHANICAL OUTLINE<br>PRINT VERSION NOT TO SCALE | STANDARD:<br>MO-220 |  |  |
|--|---------------------|--|--|

Fig 33. PCB footprint for SOT994-1 (HWQFN24); reflow soldering (3 of 3)



## 19. Abbreviations

Table 26. Abbreviations

| Acronym              | Description                             |
|----------------------|---|
| CBT                  | Cross Bar Technology                    |
| CDM                  | Charged Device Model                    |
| CMOS                 | Complementary Metal Oxide Semiconductor |
| DUT                  | Device Under Test                       |
| ESD                  | ElectroStatic Discharge                 |
| GPIO                 | General Purpose Input/Output            |
| HBM                  | Human Body Model                        |
| I/O                  | Input/Output                            |
| I <sup>2</sup> C-bus | Inter-Integrated Circuit bus            |
| IC                   | Integrated Circuit                      |
| LED                  | Light Emitting Diode                    |
| LP                   | Low Pass                                |
| MM                   | Machine Model                           |
| PLC                  | Programmable Logic Controller           |
| POR                  | Power-On Reset                          |
| RAID                 | Redundant Array of Independent Discs    |
| RF                   | Radio Frequency                         |
| SMBus                | System Management Bus                   |

## 20. Revision history

Table 27. Revision history

| Document ID    | Release date  | Data sheet status  | Change notice | Supersedes    |
|----------------|---|--------------------|---------------|---------------|
| PCA9575 v.4.4  | 20191028  | Product data sheet | 201910019I    | PCA9575 v.4.3 |
| Modifications: | <ul style="list-style-type: none"> <li>• <a href="#">Section 18 "Soldering: PCB footprints"</a>: Corrected PCB footprint for SOT994-1</li> </ul>  |                    |               |               |
| PCA9575 v.4.3  | 20190611  | Product data sheet | 201906023I    | PCA9575 v.4.2 |
| Modifications: | <ul style="list-style-type: none"> <li>• Updated temperature range for HWQFN24 from -40 °C to +85 °C to -40 °C to +105 °C</li> <li>• <a href="#">Table 22 "Static characteristics"</a>: I<sub>stbL</sub> and I<sub>stbH</sub> max changed from 2 µA to 3 µA for HWQFN24</li> </ul>  |                    |               |               |
| PCA9575 v.4.2  | 20150416  | Product data sheet | -             | PCA9575 v.4.1 |
| Modifications: | <ul style="list-style-type: none"> <li>• <a href="#">Table 22 "Static characteristics"</a>: V<sub>DD(IO)0</sub> and V<sub>DD(IO)1</sub>, clarified max from "V<sub>DD</sub> + 0.5" to "3.6 + 0.5"</li> <li>• <a href="#">Table 21 "Limiting values"</a>: V<sub>DD(IO)0</sub> and V<sub>DD(IO)1</sub>, clarified max from "V<sub>DD</sub> + 0.5" to "4.0 + 0.5"</li> </ul> |                    |               |               |
| PCA9575 v.4.1  | 20150407  | Product data sheet | -             | PCA9575 v.4   |
| PCA9575 v.4    | 20140520  | Product data sheet | -             | PCA9575 v.3   |
| PCA9575 v.3    | 20091109  | Product data sheet | -             | PCA9575 v.2   |
| PCA9575 v.2    | 20090727  | Product data sheet | -             | PCA9575 v.1   |
| PCA9575 v.1    | 20081002  | Product data sheet | -             | -             |

## 21. Legal information

### 21.1 Data sheet status

| Document status <sup>[1][2]</sup> | Product status <sup>[3]</sup> | Definition  |
|-----------------------------------|-------------------------------|---|
| Objective [short] data sheet      | Development                   | This document contains data from the objective specification for product development. |
| Preliminary [short] data sheet    | Qualification                 | This document contains data from the preliminary specification.                       |
| Product [short] data sheet        | Production                    | This document contains the product specification.                                     |

[1] Please consult the most recently issued document before initiating or completing a design.

[2] The term 'short data sheet' is explained in section "Definitions".

[3] The product status of device(s) described in this document may have changed since this document was published and may differ in case of multiple devices. The latest product status information is available on the Internet at URL <http://www.nxp.com>.

### 21.2 Definitions

**Draft** — The document is a draft version only. The content is still under internal review and subject to formal approval, which may result in modifications or additions. NXP Semiconductors does not give any representations or warranties as to the accuracy or completeness of information included herein and shall have no liability for the consequences of use of such information.

**Short data sheet** — A short data sheet is an extract from a full data sheet with the same product type number(s) and title. A short data sheet is intended for quick reference only and should not be relied upon to contain detailed and full information. For detailed and full information see the relevant full data sheet, which is available on request via the local NXP Semiconductors sales office. In case of any inconsistency or conflict with the short data sheet, the full data sheet shall prevail.

**Product specification** — The information and data provided in a Product data sheet shall define the specification of the product as agreed between NXP Semiconductors and its customer, unless NXP Semiconductors and customer have explicitly agreed otherwise in writing. In no event however, shall an agreement be valid in which the NXP Semiconductors product is deemed to offer functions and qualities beyond those described in the Product data sheet.

### 21.3 Disclaimers

**Limited warranty and liability** — Information in this document is believed to be accurate and reliable. However, NXP Semiconductors does not give any representations or warranties, expressed or implied, as to the accuracy or completeness of such information and shall have no liability for the consequences of use of such information. NXP Semiconductors takes no responsibility for the content in this document if provided by an information source outside of NXP Semiconductors.

In no event shall NXP Semiconductors be liable for any indirect, incidental, punitive, special or consequential damages (including - without limitation - lost profits, lost savings, business interruption, costs related to the removal or replacement of any products or rework charges) whether or not such damages are based on tort (including negligence), warranty, breach of contract or any other legal theory.

Notwithstanding any damages that customer might incur for any reason whatsoever, NXP Semiconductors' aggregate and cumulative liability towards customer for the products described herein shall be limited in accordance with the *Terms and conditions of commercial sale* of NXP Semiconductors.

**Right to make changes** — NXP Semiconductors reserves the right to make changes to information published in this document, including without limitation specifications and product descriptions, at any time and without notice. This document supersedes and replaces all information supplied prior to the publication hereof.

**Suitability for use** — NXP Semiconductors products are not designed, authorized or warranted to be suitable for use in life support, life-critical or safety-critical systems or equipment, nor in applications where failure or malfunction of an NXP Semiconductors product can reasonably be expected to result in personal injury, death or severe property or environmental damage. NXP Semiconductors and its suppliers accept no liability for inclusion and/or use of NXP Semiconductors products in such equipment or applications and therefore such inclusion and/or use is at the customer's own risk.

**Applications** — Applications that are described herein for any of these products are for illustrative purposes only. NXP Semiconductors makes no representation or warranty that such applications will be suitable for the specified use without further testing or modification.

Customers are responsible for the design and operation of their applications and products using NXP Semiconductors products, and NXP Semiconductors accepts no liability for any assistance with applications or customer product design. It is customer's sole responsibility to determine whether the NXP Semiconductors product is suitable and fit for the customer's applications and products planned, as well as for the planned application and use of customer's third party customer(s). Customers should provide appropriate design and operating safeguards to minimize the risks associated with their applications and products.

NXP Semiconductors does not accept any liability related to any default, damage, costs or problem which is based on any weakness or default in the customer's applications or products, or the application or use by customer's third party customer(s). Customer is responsible for doing all necessary testing for the customer's applications and products using NXP Semiconductors products in order to avoid a default of the applications and the products or of the application or use by customer's third party customer(s). NXP does not accept any liability in this respect.

**Limiting values** — Stress above one or more limiting values (as defined in the Absolute Maximum Ratings System of IEC 60134) will cause permanent damage to the device. Limiting values are stress ratings only and (proper) operation of the device at these or any other conditions above those given in the Recommended operating conditions section (if present) or the Characteristics sections of this document is not warranted. Constant or repeated exposure to limiting values will permanently and irreversibly affect the quality and reliability of the device.

**Terms and conditions of commercial sale** — NXP Semiconductors products are sold subject to the general terms and conditions of commercial sale, as published at <http://www.nxp.com/profile/terms>, unless otherwise agreed in a valid written individual agreement. In case an individual agreement is concluded only the terms and conditions of the respective agreement shall apply. NXP Semiconductors hereby expressly objects to applying the customer's general terms and conditions with regard to the purchase of NXP Semiconductors products by customer.

**No offer to sell or license** — Nothing in this document may be interpreted or construed as an offer to sell products that is open for acceptance or the grant, conveyance or implication of any license under any copyrights, patents or other industrial or intellectual property rights.

**Export control** — This document as well as the item(s) described herein may be subject to export control regulations. Export might require a prior authorization from competent authorities.

**Non-automotive qualified products** — Unless this data sheet expressly states that this specific NXP Semiconductors product is automotive qualified, the product is not suitable for automotive use. It is neither qualified nor tested in accordance with automotive testing or application requirements. NXP Semiconductors accepts no liability for inclusion and/or use of non-automotive qualified products in automotive equipment or applications.

In the event that customer uses the product for design-in and use in automotive applications to automotive specifications and standards, customer (a) shall use the product without NXP Semiconductors' warranty of the product for such automotive applications, use and specifications, and (b) whenever customer uses the product for automotive applications beyond NXP Semiconductors' specifications such use shall be solely at customer's

own risk, and (c) customer fully indemnifies NXP Semiconductors for any liability, damages or failed product claims resulting from customer design and use of the product for automotive applications beyond NXP Semiconductors' standard warranty and NXP Semiconductors' product specifications.

**Translations** — A non-English (translated) version of a document is for reference only. The English version shall prevail in case of any discrepancy between the translated and English versions.

## 21.4 Trademarks

Notice: All referenced brands, product names, service names and trademarks are the property of their respective owners.

**I<sup>2</sup>C-bus** — logo is a trademark of NXP Semiconductors N.V.

## 22. Contact information

For more information, please visit: <http://www.nxp.com>

For sales office addresses, please send an email to: [salesaddresses@nxp.com](mailto:salesaddresses@nxp.com)

23. Contents

|        |   |    |      |  |    |
|--------|---|----|------|--|----|
| 1      | <b>General description</b> . . . . .                                | 1  | 9    | <b>Bus transactions</b> . . . . .                  | 22 |
| 2      | <b>Features and benefits</b> . . . . .                              | 2  | 10   | <b>Application design-in information</b> . . . . . | 24 |
| 3      | <b>Applications</b> . . . . .                                       | 3  | 11   | <b>Limiting values</b> . . . . .                   | 24 |
| 4      | <b>Ordering information</b> . . . . .                               | 3  | 12   | <b>Static characteristics</b> . . . . .            | 25 |
| 4.1    | Ordering options . . . . .  | 3  | 13   | <b>Dynamic characteristics</b> . . . . .           | 27 |
| 5      | <b>Block diagram</b> . . . . .                                      | 4  | 14   | <b>Test information</b> . . . . .                  | 29 |
| 6      | <b>Pinning information</b> . . . . .                                | 6  | 15   | <b>Package outline</b> . . . . .                   | 30 |
| 6.1    | Pinning . . . . .   | 6  | 16   | <b>Handling information</b> . . . . .              | 33 |
| 6.2    | Pin description . . . . .   | 7  | 17   | <b>Soldering of SMD packages</b> . . . . .         | 33 |
| 7      | <b>Functional description</b> . . . . .                             | 8  | 17.1 | Introduction to soldering . . . . .                | 33 |
| 7.1    | I/O ports . . . . .   | 8  | 17.2 | Wave and reflow soldering . . . . .                | 33 |
| 7.2    | Device address . . . . .  | 8  | 17.3 | Wave soldering . . . . .                           | 33 |
| 7.3    | Command register . . . . .  | 9  | 17.4 | Reflow soldering . . . . .                         | 34 |
| 7.4    | Register definitions . . . . .                                      | 9  | 18   | <b>Soldering: PCB footprints</b> . . . . .         | 36 |
| 7.5    | Writing to port registers . . . . .                                 | 10 | 19   | <b>Abbreviations</b> . . . . .                     | 41 |
| 7.6    | Reading the port registers . . . . .                                | 10 | 20   | <b>Revision history</b> . . . . .                  | 41 |
| 7.6.1  | Register 0 - Input port 0 register . . . . .                        | 10 | 21   | <b>Legal information</b> . . . . .                 | 42 |
| 7.6.2  | Register 1 - Input port 1 register . . . . .                        | 11 | 21.1 | Data sheet status . . . . .                        | 42 |
| 7.6.3  | Register 2 - Polarity inversion port 0 register . . . . .           | 11 | 21.2 | Definitions . . . . .                              | 42 |
| 7.6.4  | Register 3 - Polarity inversion port 1 register . . . . .           | 12 | 21.3 | Disclaimers . . . . .                              | 42 |
| 7.6.5  | Register 4 - Bus-hold/pull-up/pull-down enable 0 register . . . . . | 12 | 21.4 | Trademarks . . . . .                               | 43 |
| 7.6.6  | Register 5 - Bus-hold/pull-up/pull-down enable 1 register . . . . . | 13 | 22   | <b>Contact information</b> . . . . .               | 43 |
| 7.6.7  | Register 6 - Pull-up/pull-down select port 0 register . . . . .     | 14 | 23   | <b>Contents</b> . . . . .                          | 44 |
| 7.6.8  | Register 7 - Pull-up/pull-down select port 1 register . . . . .     | 14 |      |  |    |
| 7.6.9  | Register 8 - Configuration port 0 register . . . . .                | 15 |      |  |    |
| 7.6.10 | Register 9 - Configuration port 1 register . . . . .                | 15 |      |  |    |
| 7.6.11 | Register 10 - Output port 0 register . . . . .                      | 16 |      |  |    |
| 7.6.12 | Register 11 - Output port 1 register . . . . .                      | 16 |      |  |    |
| 7.6.13 | Register 12 - Interrupt mask port 0 register . . . . .              | 17 |      |  |    |
| 7.6.14 | Register 13 - Interrupt mask port 1 register . . . . .              | 17 |      |  |    |
| 7.6.15 | Register 14 - Interrupt status port 0 register . . . . .            | 18 |      |  |    |
| 7.6.16 | Register 15 - Interrupt status port 1 register . . . . .            | 18 |      |  |    |
| 7.7    | Power-on reset . . . . .  | 18 |      |  |    |
| 7.8    | RESET input . . . . .   | 18 |      |  |    |
| 7.9    | Software reset . . . . .  | 19 |      |  |    |
| 7.10   | Interrupt output ( $\overline{INT}$ ) . . . . .                     | 19 |      |  |    |
| 7.11   | Standby . . . . .   | 19 |      |  |    |
| 8      | <b>Characteristics of the I<sup>2</sup>C-bus</b> . . . . .          | 20 |      |  |    |
| 8.1    | Bit transfer . . . . .  | 20 |      |  |    |
| 8.1.1  | START and STOP conditions . . . . .                                 | 20 |      |  |    |
| 8.2    | System configuration . . . . .                                      | 20 |      |  |    |
| 8.3    | Acknowledge . . . . .   | 21 |      |  |    |

Please be aware that important notices concerning this document and the product(s) described herein, have been included in section 'Legal information'.

© NXP Semiconductors N.V. 2019. All rights reserved.

For more information, please visit: <http://www.nxp.com>  
 For sales office addresses, please send an email to: [salesaddresses@nxp.com](mailto:salesaddresses@nxp.com)

Date of release: 28 October 2019  
 Document identifier: PCA9575



Компания «ЭлектроПласт» предлагает заключение долгосрочных отношений при поставках импортных электронных компонентов на взаимовыгодных условиях!

Наши преимущества:

- Оперативные поставки широкого спектра электронных компонентов отечественного и импортного производства напрямую от производителей и с крупнейших мировых складов;
- Поставка более 17-ти миллионов наименований электронных компонентов;
- Поставка сложных, дефицитных, либо снятых с производства позиций;
- Оперативные сроки поставки под заказ (от 5 рабочих дней);
- Экспресс доставка в любую точку России;
- Техническая поддержка проекта, помощь в подборе аналогов, поставка прототипов;
- Система менеджмента качества сертифицирована по Международному стандарту ISO 9001;
- Лицензия ФСБ на осуществление работ с использованием сведений, составляющих государственную тайну;
- Поставка специализированных компонентов (Xilinx, Altera, Analog Devices, Intersil, Interpoint, Microsemi, Aeroflex, Peregrine, Syfer, Eurofarad, Texas Instrument, Miteq, Cobham, E2V, MA-COM, Hittite, Mini-Circuits, General Dynamics и др.);

Помимо этого, одним из направлений компании «ЭлектроПласт» является направление «Источники питания». Мы предлагаем Вам помощь Конструкторского отдела:

- Подбор оптимального решения, техническое обоснование при выборе компонента;
- Подбор аналогов;
- Консультации по применению компонента;
- Поставка образцов и прототипов;
- Техническая поддержка проекта;
- Защита от снятия компонента с производства.



#### Как с нами связаться

**Телефон:** 8 (812) 309 58 32 (многоканальный)

**Факс:** 8 (812) 320-02-42

**Электронная почта:** [org@eplast1.ru](mailto:org@eplast1.ru)

**Адрес:** 198099, г. Санкт-Петербург, ул. Калинина, дом 2, корпус 4, литера А.