

ZXCT1107/1109/1110 LOW POWER HIGH-SIDE CURRENT MONITORS

Description

The ZXCT1107/09/10 are high side unipolar current sense monitors. These devices eliminate the need to disrupt the ground plane when sensing a load current.

The wide common-mode input voltage range and low quiescent current coupled with SOT23 packages make them suitable for a range of applications; including adapters, automotive and systems operating from industrial 24V rails.

The device is line powered and as such doesn't need a separate supply rail.

Quiescent current is only 3 μ A thereby minimising current sensing error. One external gain setting resistor increases versatility by permitting wide gain ranges.

Features

- Wide supply and common-mode voltage range: 2.5V to 36V
- SOT23 packages
 - 3-pin ZXCT1107/09
 - 5-pin ZXCT1110
- Low quiescent current (3 μ A).
- Extended industrial temperature range -40 to 125°C
- AEC-Q100 Grade1 Automotive qualified variants

Applications

- Automotive current measurement
- Industrial applications current measurement
- Battery management
- Over current monitor
- Power Management

Pin Assignments

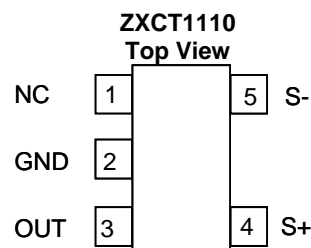
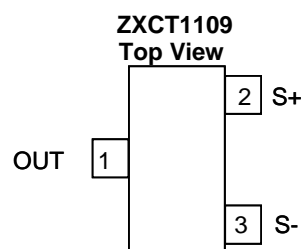
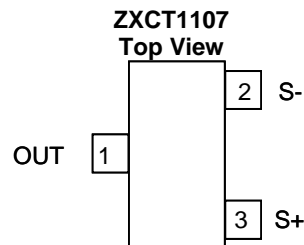

Typical Application Circuit

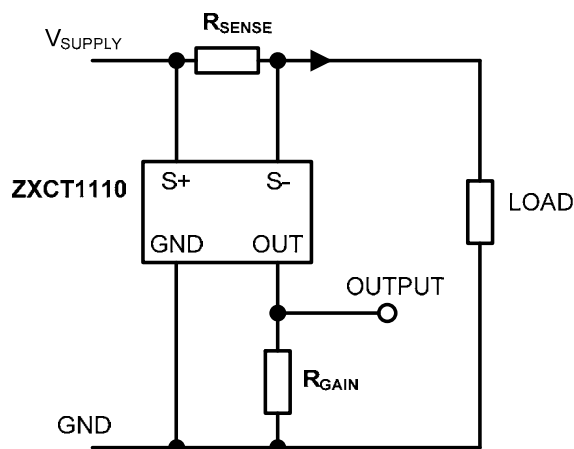
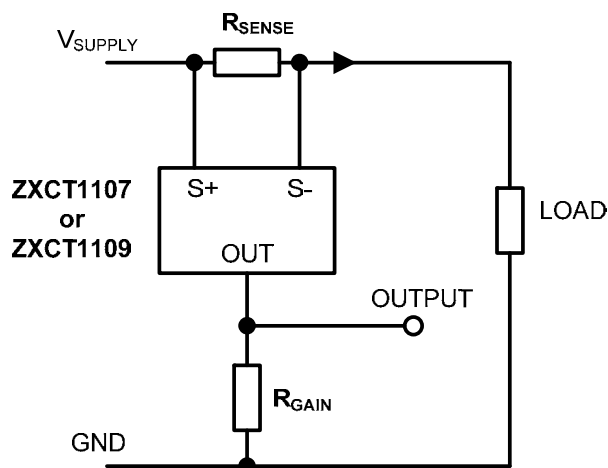

ZXCT1107/1109/1110 LOW POWER HIGH-SIDE CURRENT MONITORS

Pin Descriptions

Package	SOT23		SOT25	Description
	ZXCT1107	ZXCT1109	ZXCT1110	
OUT	1 ¹	1 ¹	3	Output pin. Current output.
S+	3	2	4	This is the positive input of the current monitor and has a wide common-mode input range. This also acts as the analog supply and provides power to internal circuitry. The current through this pin varies with differential sense voltage.
S-	2	3	5	This is the negative input of the current monitor and has a wide common-mode input range.
GND	-	-	2	Ground pin and substrate connection.
NC	-	-	1	No connection

Notes: 1. For the ZXCT1107 and ZXCT1109 pin 1 (OUT) acts as both the output pin and substrate connection. This means that for the ZXCT1107 and ZXCT1109 the minimum rail voltage that can be used is $2.5V + V_{OUT}$ (see applications section for more details).

Absolute Maximum Ratings

Description	Rating	Unit
Voltage on S- and S+ relative to OUT (ZXCT1107/9)	-0.3 to 40	V
Voltage on S- and S+ relative to GND (ZXCT1110)	-0.3 to 40	V
Voltage on OUT to GND (ZXCT1110)	-0.3 to V_{S+}	V
Differential Sense Voltage, V_{SENSE} ^{2,3}	-0.3 to 0.8	V
Current into S+ and S- ³	±8.5	mA
Storage Temperature	-55 to 150	°C
Maximum Junction Temperature	150	°C
Package Power Dissipation ($T_A = 25^\circ\text{C}$)		
SOT23	300 (De-rate to Zero at 150°C)	mW
SOT25	300 (De-rate to Zero at 150°C)	
ESD Ratings		
Human Body Model	1000	V
Machine Model	150	V

Operation above the absolute maximum rating may cause device failure. Operation at the absolute maximum ratings, for extended periods, may reduce device reliability.

Notes: 2. $V_{SENSE} = V_{S+} - V_{S-}$
3. The differential input voltage limit, $V_{S+} - V_{S-}$, may be exceeded provided that the input current limit into S+ or S- is not exceeded.

ZXCT1107/1109/1110 LOW POWER HIGH-SIDE CURRENT MONITORS

Recommended Operating Conditions

Symbol	Parameter	Min	Max	Unit	
V _{S+}	Common-mode input range ⁴ :	ZXCT1110	2.5	36	V
		ZXCT1107/9	V _{OUT(MAX)} + 2.5	36	
V _{SENSE}	Differential Sense Input voltage range (V _{S+} -V _{S-})	0	0.5	V	
V _{OUT}	Output voltage range (0 ≤ V _{SENSE} ≤ 100mV)	ZXCT1110	0	V _{S-} - 1	V
		ZXCT1107/9	0	V _{S+} - 2.5	
T _A	Ambient temperature range	-40	125	°C	

Notes. 4. For the ZXCT1107 and ZXCT1109 pin 1 (OUT) acts as both the output pin and substrate connection. This means that for the ZXCT1107 and ZXCT1109 the minimum rail voltage that can be used is 2.5V + V_{OUT} (see applications section for more details).

Electrical Characteristics (T_A = 25°C, V_{S+} = 20V, V_{SENSE}⁵ = 100mV, R_{GAIN} = 0 unless otherwise stated)

ZXCT1107, ZXCT1109

Symbol	Parameter	Conditions	T _A	Min	Typ	Max	Units
I _{S-}	S- input current	V _{SENSE} ⁵ = 0V	25°C		19	100	nA
			-40°C		16		
			125°C		35		
I _{OUT}	Output current ⁶	V _{SENSE} ⁵ = 0mV	25°C	1	3	10	μA
			-40°C		2.2		
			125°C		5.5		
		V _{SENSE} ⁵ = 10mV	25°C	37	45	54	
			-40°C		42		
			125°C		49		
		V _{SENSE} ⁵ = 30mV	25°C	115	124	134	
			-40°C		119		
			125°C		129		
		V _{SENSE} ⁵ = 100mV	25°C	394	408	422	
			-40°C		396		
			125°C		420		
		V _{SENSE} ⁵ = 200mV	25°C	787	810	832	
			-40°C		785		
			125°C		832		
		V _{SENSE} ⁵ = 500mV	25°C	1.965	2.015	2.064	mA
			-40°C		1.965		
			125°C		2.065		
I _{OUT-TC}	Output current temperature coefficient		full range		370		ppm/°C
CMSR	Common-Mode Sense rejection	V _{S+} = 2.5V to 36V	25°C		0.1	0.4	μA/V
			-40°C		0.13		
			125°C		0.05		
BW	-3dB Small Signal Bandwidth	V _{SENSE} ⁵ (AC) = 10mV _{PP} R _{GAIN} = 2.5kΩ	25°C		0.65		MHz

ZXCT1107/1109/1110 LOW POWER HIGH-SIDE CURRENT MONITORS

Electrical Characteristics ($T_A = 25^\circ\text{C}$, $V_{S+} = 20\text{V}$, $V_{\text{SENSE}}^5 = 100\text{mV}$, $R_{\text{GAIN}} = 0$ unless otherwise stated) (cont.)

ZXCT1110

Symbol	Parameter	Conditions	T_A	Min	Typ	Max	Units
I_Q	GND pin current	$V_{\text{SENSE}}^5 = 0\text{V}$	25°C		3	5	μA
			-40°C		2.2		
			125°C		5.8		
I_{S-}	S- input current	$V_{\text{SENSE}}^5 = 0\text{V}$	25°C		19	100	nA
			-40°C		16		
			125°C		35		
CMSR	Common-Mode Sense rejection	$V_{S+} = 2.5\text{V to } 36\text{V}$	25°C		0.1	0.4	$\mu\text{A/V}$
			-40°C		0.13		
			125°C		0.05		
I_{OO}	Output Offset current ^{6,7}	$V_{\text{SENSE}}^5 = 10\text{mV}$	25°C		0	± 4	μA
			-40°C		-1.8		
			125°C		+2.5		
G_T	Transconductance	$V_{\text{SENSE}}^5 = 10\text{mV to } 150\text{mV}$	25°C	3.928	4	4.072	mA/V
			-40°C		3.9		
			125°C		4.08		
GE	Transconductance error	$V_{\text{SENSE}}^5 = 10\text{mV to } 150\text{mV}$	25°C	-1.8		1.8	%
$I_{OUT} G_{T-TC}$	Transconductance temp.co		25°C		265		ppm/°C
V_{OUTH}	Output relative to V_{S-}		25°C	-1	-0.78		V
			-40°C		-0.88		
			125°C		-0.63		
BW	-3dB Small Signal Bandwidth	$V_{\text{SENSE}}^5 (AC) = 10\text{mV}_{PP}$, $R_{\text{GAIN}} = 2.5\text{k}\Omega$	25°C		0.65		MHz

- Notes.
5. $V_{\text{SENSE}} = "V_{\text{SENSE}+}" - "V_{\text{SENSE}-}"$
 6. Output current characteristic measured with low impedance ammeter connected to GND
 7. Defined as difference between actual output current and $40\mu\text{A}$; measured at $V_{\text{SENSE}} = 10\text{mV}$. This will include an error due to bias currents of the device.
 8. For $V_{\text{SENSE}} > 10\text{mV}$, the internal voltage-current converter is fully linear. This enables a true offset to be defined and used.

ZXCT1107/1109/1110
LOW POWER HIGH-SIDE CURRENT MONITORS

Typical Characteristics

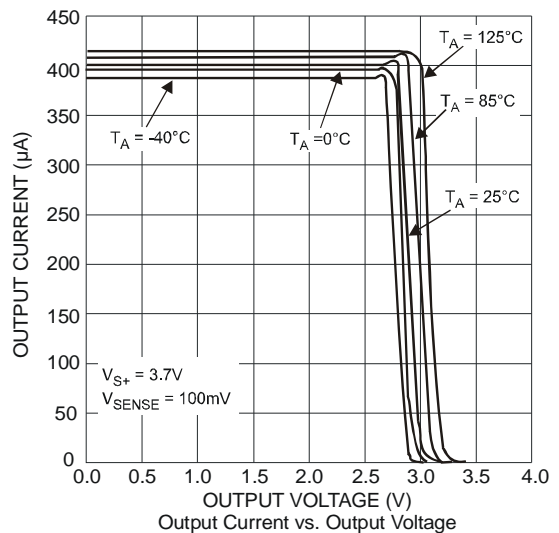
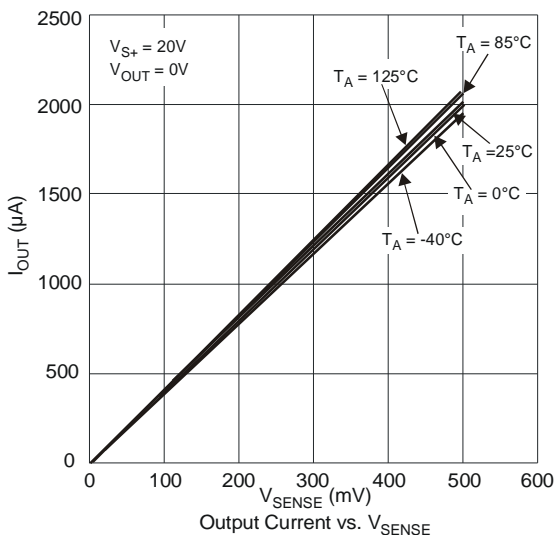
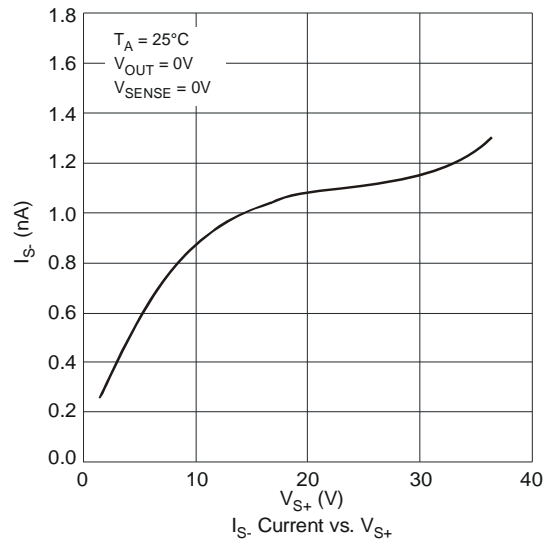
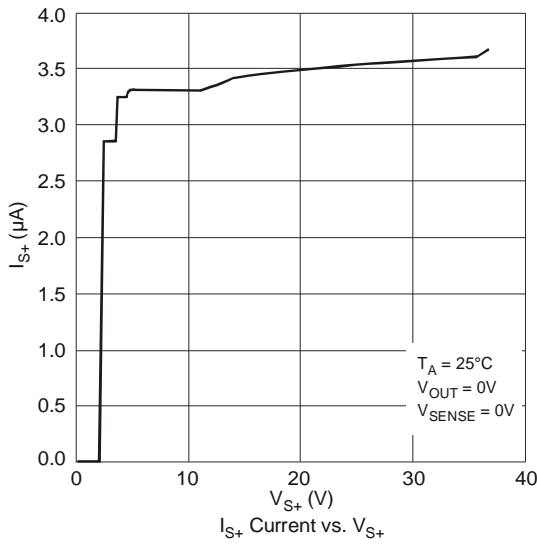
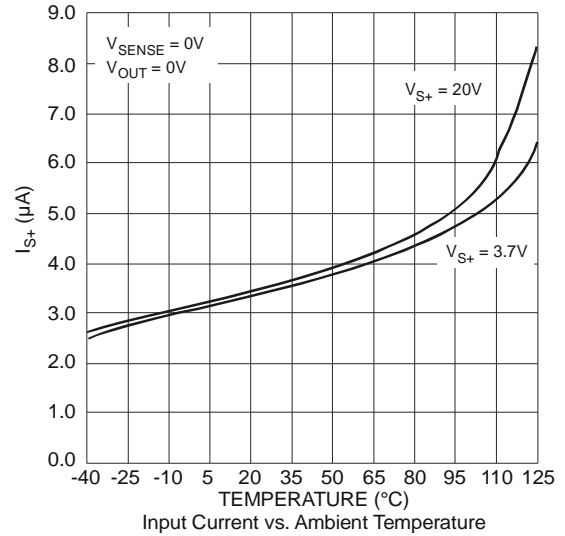
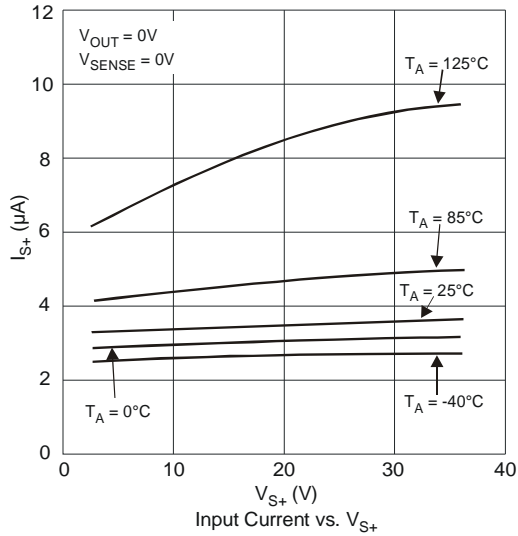

ZXCT1107/1109/1110
LOW POWER HIGH-SIDE CURRENT MONITORS

Typical Characteristics (cont.)

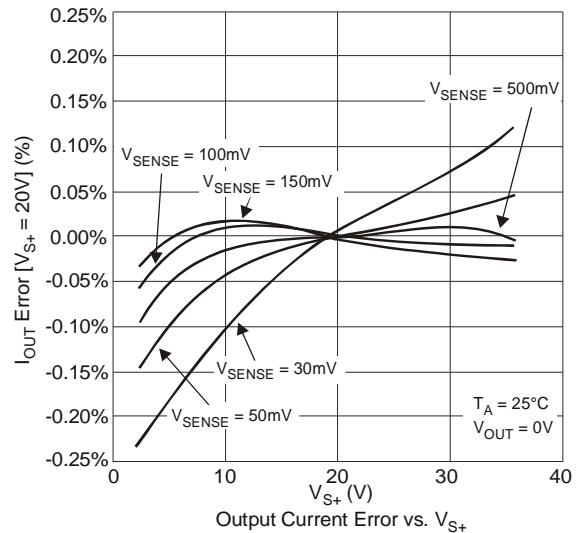
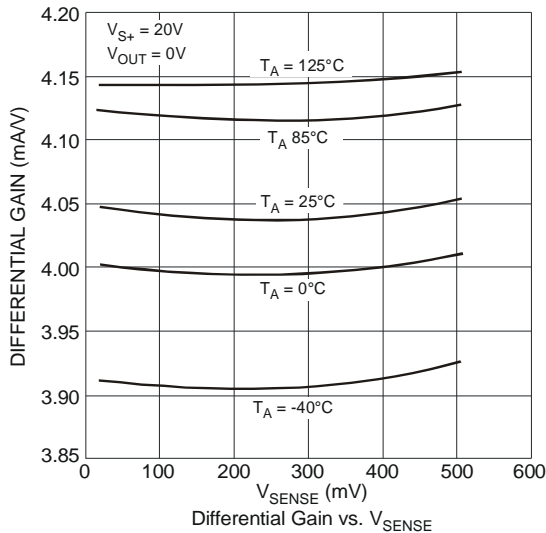
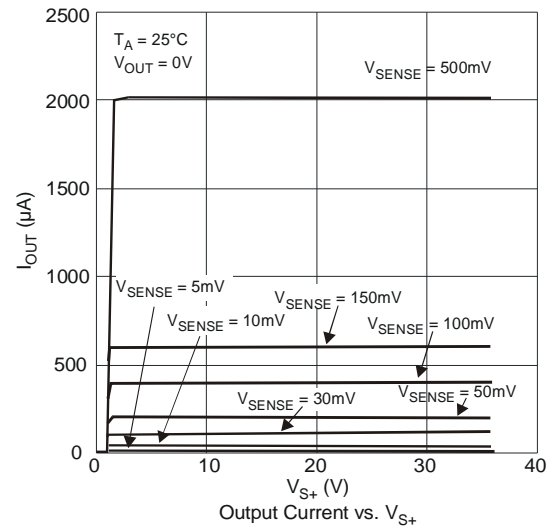
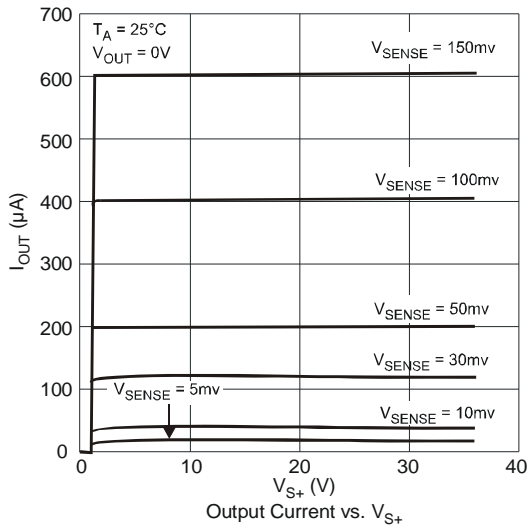
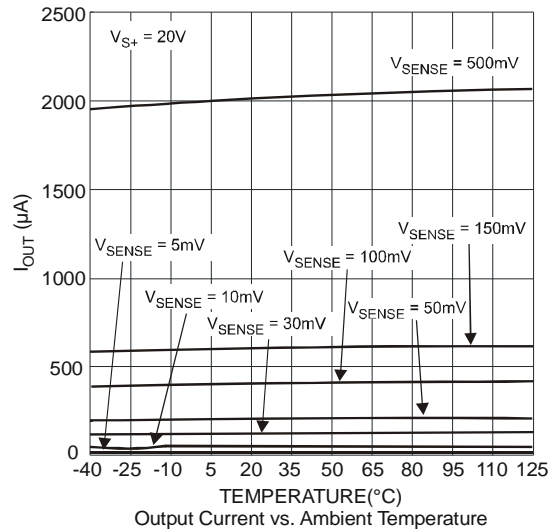
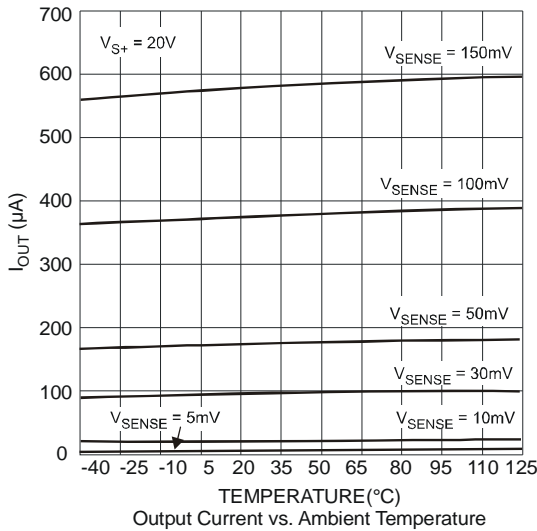

ZXCT1107/1109/1110
LOW POWER HIGH-SIDE CURRENT MONITORS

Typical Characteristics (cont.)

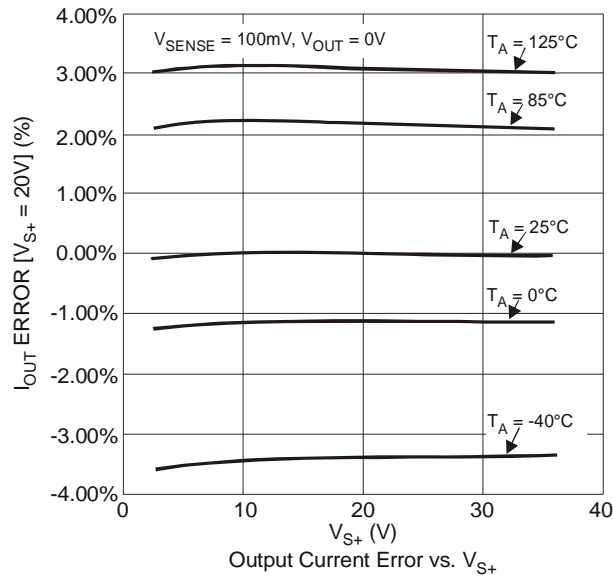

ZXCT1107/1109/1110
LOW POWER HIGH-SIDE CURRENT MONITORS

Typical AC Characteristics

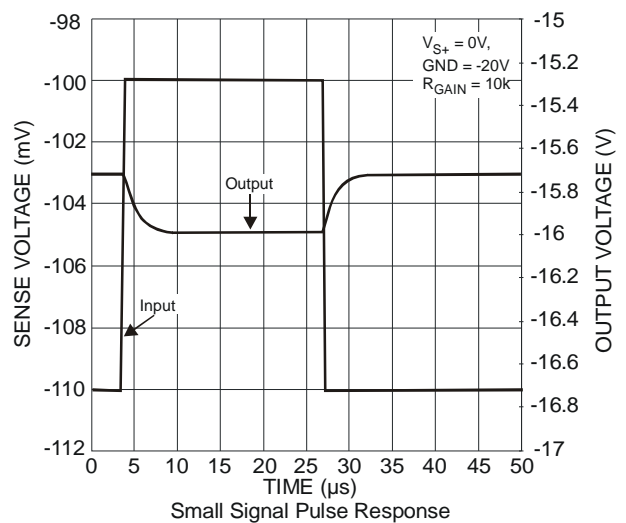
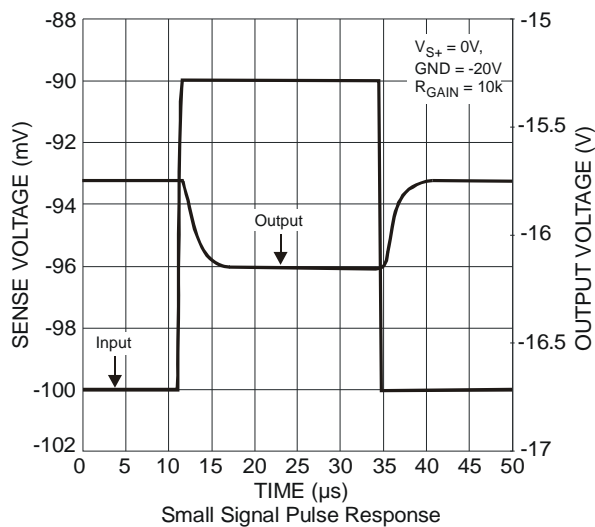
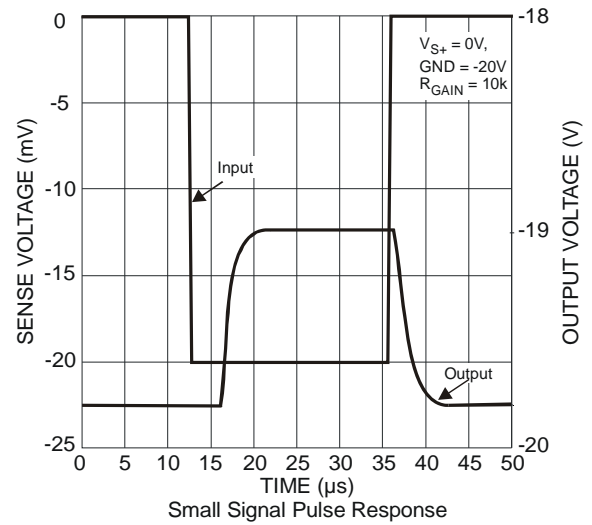
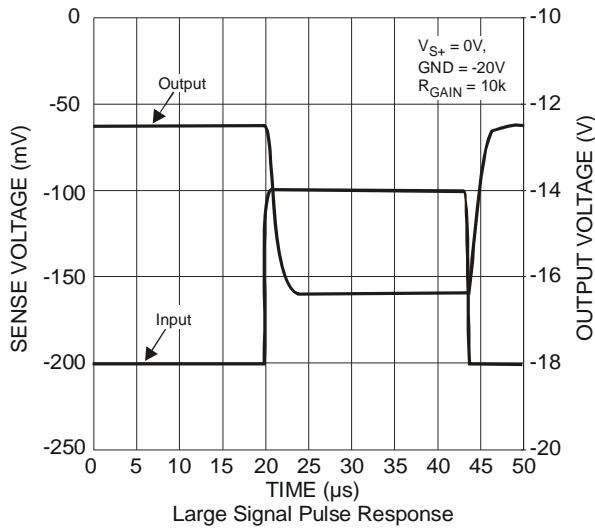
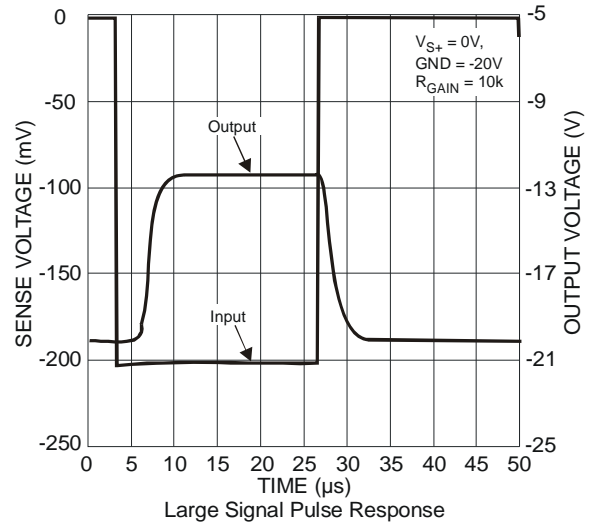
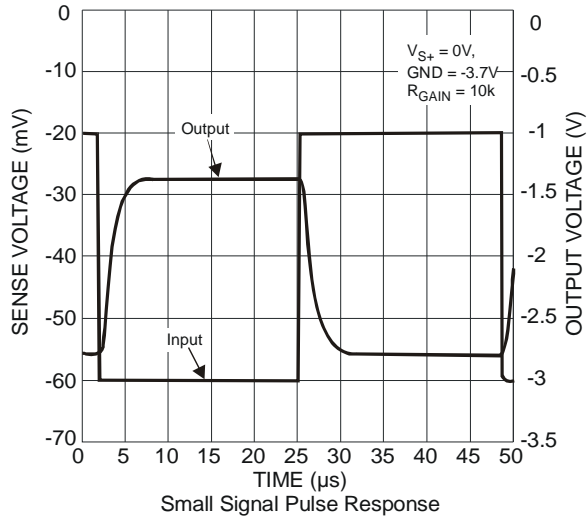

ZXCT1107/1109/1110
LOW POWER HIGH-SIDE CURRENT MONITORS

Typical AC Characteristics (cont.)

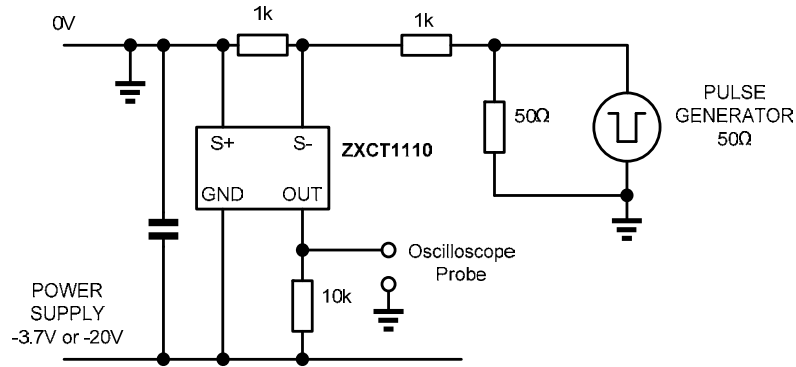

Test Circuit for Pulse Response

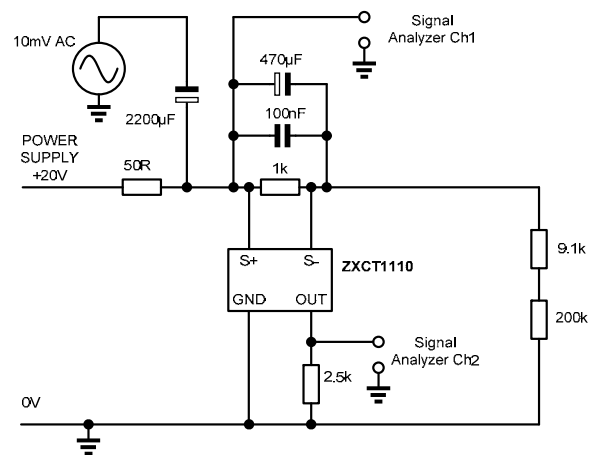
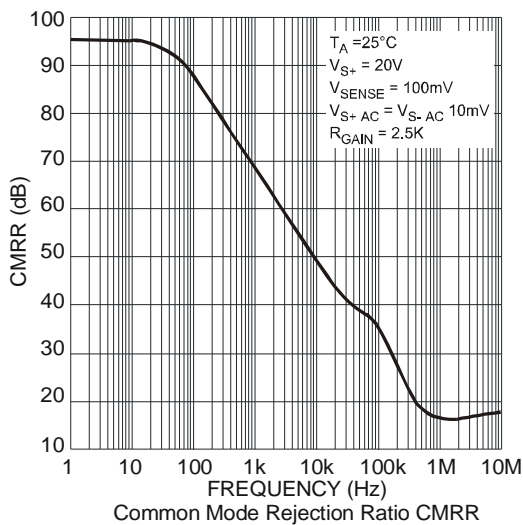

Test circuit for CMRR

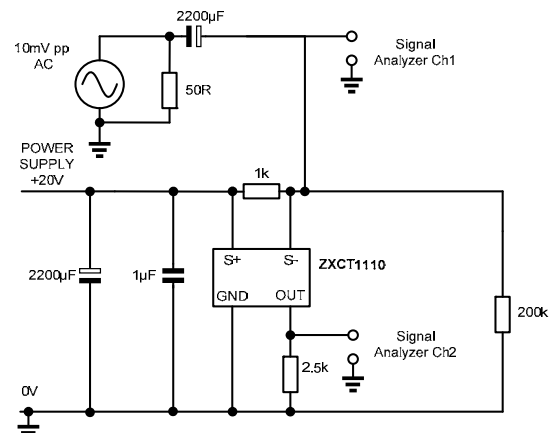
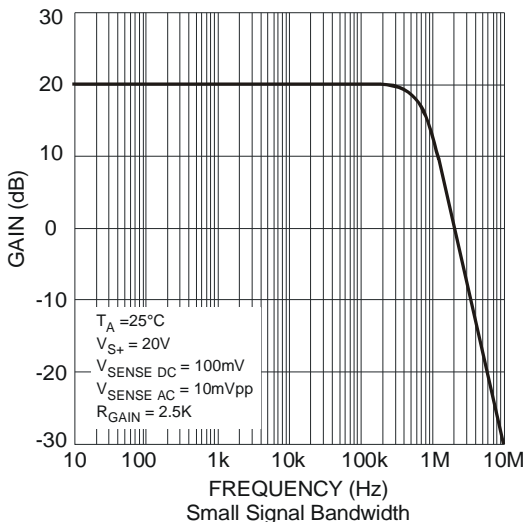

Test circuit for Small signal bandwidth

ZXCT1107/1109/1110
LOW POWER HIGH-SIDE CURRENT MONITORS

Application Information

Description

The current monitor ICs ZXCT1107, ZXCT1109 and ZXCT1110 all use a similar application circuit topology for high-side current sensing, with small differences. The ZXCT1110 has a separate ground pin whereas the ZXCT1107 and ZXCT1109 do not. The use of ZXCT1110 allows reduction of the absolute current measurement error in some applications by providing a reduced output offset current. The ZXCT1107 provides a mirror image pin assignment of the ZXCT1109 to ease PCB layout in very small equipment designs.

The basic application circuit for each device is shown in Figure 1. Two external resistors are required. The resistor R_{SENSE} is connected in the path of the current to be monitored. The resistor R_{GAIN} converts the device output current to a voltage for convenient processing by a further device, such as a comparator, amplifier or analog-to-digital converter within a microcontroller system.

The current monitor output current is defined through the nominal transconductance of 4mA/V.

$$I_{OUT} = 0.004 * V_{SENSE} \quad \text{Amp} \quad \text{Equation 1}$$

Then the resistors determine the output voltage as described below.

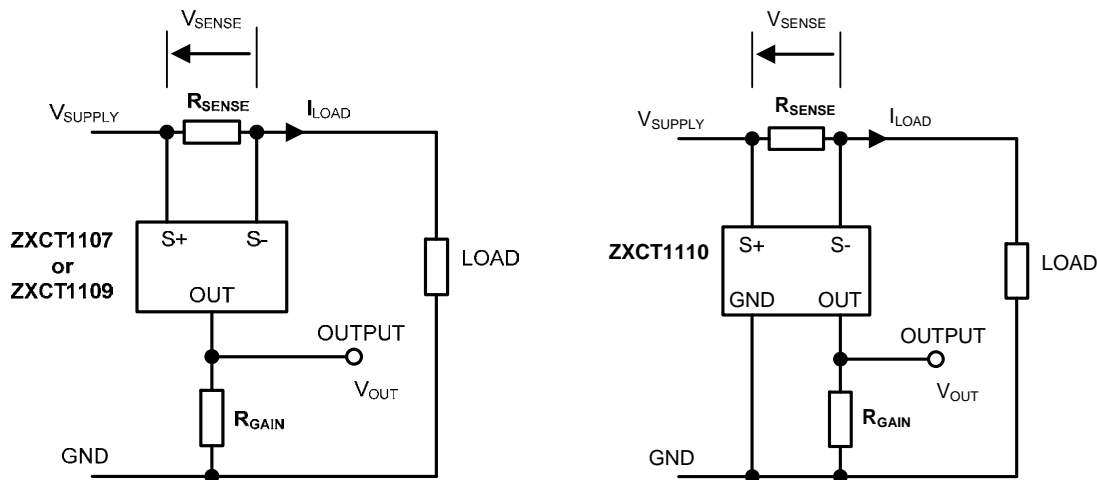

Figure 1. Basic Application Circuit

Calculation of Resistor Values

In order to select R_{SENSE} , a choice of sense voltage is required. This often involves a compromise between power efficiency and accuracy for the given temperature range. The resistor must be small enough to avoid excessive volt drop between the power supply and the load. However, the resistor must be large enough to avoid excessive current measurement error, particularly random errors.

In a typical application, a digital system, perhaps a microcontroller, is set up to monitor the current. At a certain threshold current level, I_{LOADT} , the system is required to disconnect the load or report a fault. At this current level, the current measurement error must be limited to a known value. The total percentage error comprises the inherent error in the ZXCT1107/1109/1110 device and the tolerances of the two resistors R_{SENSE} and R_{GAIN} . The ZXCT1107/ZXCT1109 absolute error is shown in Table 1 with error limits drawn from the table of Electrical Characteristics above. This error varies with V_{SENSE} .

ZXCT1107/1109/1110 LOW POWER HIGH-SIDE CURRENT MONITORS

Application Information (cont.)

The ZXCT1110 is highly linear and has a transconductance of 4mA/V $\pm 1.8\%$ and an output of 40 μ A $\pm 4\mu$ A at $V_{SENSE}=10$ mV. The output current can therefore be calculated (Standard International Units) as:

$$I_{OUT} = (40 \pm 4) \times 10^{-6} + (V_{SENSE} - 0.01) \times (0.004 \pm 0.000072) \text{ Amp}$$

The worst-case current error is then

$$I_{OUTERROR} = I_{OUT} - I_{OUTIDEAL} = \pm \{ 4 \times 10^{-6} + (V_{SENSE} - 0.01) \times 0.000072 \} \text{ Amp}$$

or
$$I_{OUTERROR} = \pm \{ 3.28 \times 10^{-6} + V_{SENSE} \times 0.000072 \} \text{ A}$$

The percentage error is

$$\varepsilon = \frac{I_{OUTERROR}}{I_{OUTIDEAL}} \times 100\% = \frac{I_{OUTERROR}}{V_{SENSE} \times 0.004} \times 100\%$$

Then
$$\varepsilon = \pm \frac{3.28 \times 10^{-4} + V_{SENSE} \times 0.0072}{V_{SENSE} \times 0.004} \%$$

or
$$\varepsilon = \pm \frac{0.082}{V_{SENSE}} \pm 1.8\% \tag{Equation 2}$$

This shows that the error is reduced with increasing V_{SENSE} . Then the minimum V_{SENSE} required to give the error $\pm \varepsilon$ % is

$$V_{SENSE} = \frac{0.082}{\varepsilon - 1.8} \text{ V} \quad [only \text{ for } ZXCT1110] \tag{Equation 3}$$

In the application, the effect of the external resistor tolerances must also be taken into account.

Table 1: ZXCT1107/ZXCT1109 Error

V_{SENSE}	Mean I_{OUT}	Error Band	Percent Error
10mV	45.5 μ A	$\pm 8.5\mu$ A	$\pm 18.7\%$
30mV	124.5 μ A	$\pm 9.5\mu$ A	$\pm 7.6\%$
100mV	408 μ A	$\pm 14\mu$ A	$\pm 3.4\%$
200mV	809.5 μ A	$\pm 22.5\mu$ A	$\pm 2.8\%$

Table 2: ZXCT1110 Error

V_{SENSE}	Mean I_{OUT}	Error Band	Percent Error
10mV	40 μ A	$\pm 4\mu$ A	$\pm 10\%$
30mV	120 μ A	$\pm 5.44\mu$ A	$\pm 4.53\%$
100mV	400 μ A	$\pm 10.48\mu$ A	$\pm 2.62\%$
200mV	800 μ A	$\pm 17.68\mu$ A	$\pm 2.21\%$

ZXCT1107/1109/1110
LOW POWER HIGH-SIDE CURRENT MONITORS

Application Information (cont.)

Note that in order to avoid additional error, V_{SUPPLY} must be at least 1.5V greater than V_{OUT} . This margin depends on the value of V_{SENSE} . For $V_{SENSE} = 100mV$, this margin can be reduced to 1.0V.

R_{SENSE} is chosen based on the threshold V_{SENSET} of sense voltage selected as above, for the chosen threshold load current, I_{LOADT} .

$$R_{SENSE} = \frac{V_{SENSET}}{I_{LOADT}} \quad \text{Equation 4}$$

R_{GAIN} is chosen to give the required threshold output voltage, V_{OUTT} . From Equation 1, the threshold output current is

$$I_{OUTT} = 0.004 * V_{SENSET} \quad \text{Equation 1a}$$

$$R_{GAIN} = \frac{V_{OUTT}}{I_{OUTT}}$$

or
$$R_{GAIN} = \frac{V_{OUTT}}{0.004 * V_{SENSET}} \quad \text{Equation 5}$$

Design Example

A current monitor is required to provide an output voltage of 2V \pm 6% when the load current of a 12V supply is 2A. Resistors are available with 1% tolerance.

The sense and output resistors will contribute a total possible error of 2%, so the ZXCT11xx error must not exceed 4%. From Table 1, the error of ZXCT1107/1109 will be 3.4% if the sense voltage is 100mV. This satisfies the total error requirement of 6%.

Equation 4 gives

$$R_{SENSE} = 100mV/2A = 50m\Omega$$

Equation 5 gives

$$R_{GAIN} = \frac{2}{0.004 * 0.1} = 5k\Omega$$

A suitable preferred value is 5.1k Ω . This gives a systematic error of +2%, which can be compensated elsewhere in the system if desired. Figure 2 shows the resulting schematic.

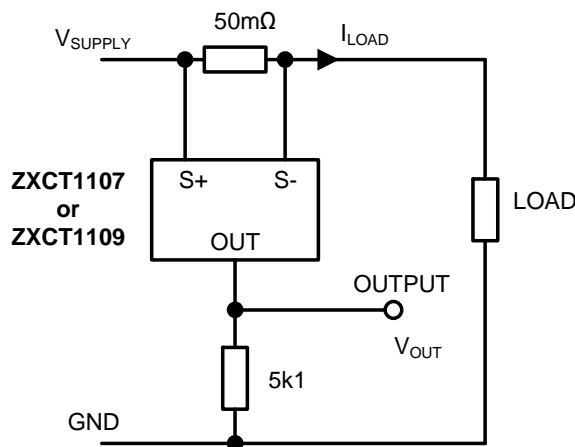

Figure 2. Example Circuit using ZXCT1107/ZXCT1109

ZXCT1107/1109/1110
LOW POWER HIGH-SIDE CURRENT MONITORS

Application Information (cont.)

Alternatively, the ZXCT1110 may be used with a reduced sense voltage if desired. From Equation 3, with $\epsilon=4\%$,

$$V_{\text{SENSE}} = \frac{0.082}{\epsilon - 1.8} = 0.082 / (4 - 1.8) = 37.2\text{mV}$$

Equation 4 gives

$$R_{\text{SENSE}} = 37.2\text{mV} / 2\text{A} = 18.6\text{m}\Omega$$

A suitable preferred value is 20m Ω . Then the sense voltage will be 2A * 20m Ω = 40mV.

Equation 5 gives

$$R_{\text{GAIN}} = \frac{2}{0.004 * 0.04} = 12500\Omega$$

A suitable preferred value is 13k Ω .

The alternative example circuit using the ZXCT1110 with a sense voltage of 40mV is shown in Figure 3, giving the required overall accuracy of $\pm 6\%$.

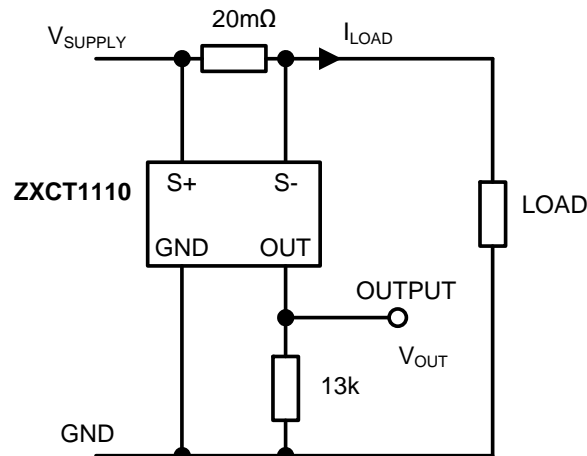

Figure 3. Example Circuit using ZXCT1110

Protection Against Load Short Circuit

In the event of a load short circuit or overload, a large proportion of the supply voltage may appear between the sense terminals. The supply may be current limited, but there is normally a large reservoir capacitor which can deliver enough energy to damage the ZXCT11xx before the supply voltage falls to a safe level due to current limit activation.

The ZXCT11xx is rated for a maximum sense voltage of +0.8V, but is safe if the input current is limited to $\pm 8.5\text{mA}$. In Figure 4, the resistor R_{PROT} limits the current and therefore protects the current monitor device against load short circuit without introducing significant current measurement error.

ZXCT1107/1109/1110
LOW POWER HIGH-SIDE CURRENT MONITORS

Application Information (cont.)

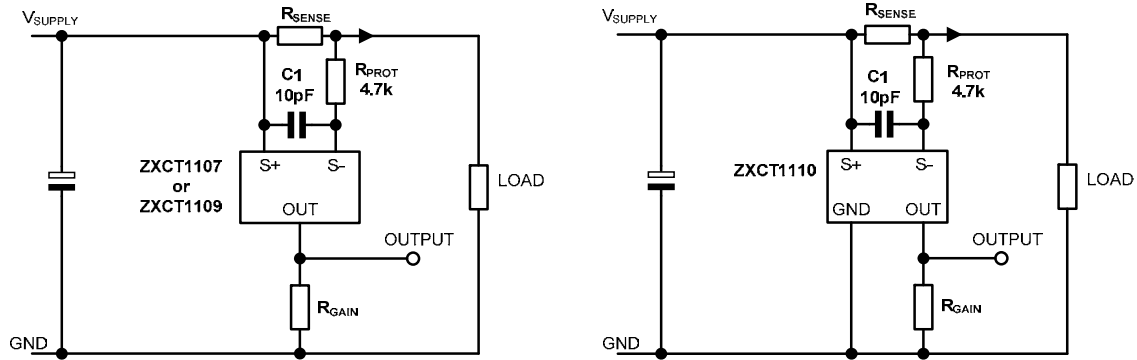

Figure 4. Protection and EMC Filtering

EMC Susceptibility

In many applications, the circuit is required to operate in the presence of RF radiation. This radiation is coupled into the circuit via the supply or load connections and will often cause significant bias shift due to rectification within the integrated circuit. The bias shift may lead to erroneous operation of the integrated circuit. In Figure 4, a low pass filter, R_{PROT} and $C1$, provides significant attenuation in the VHF and UHF regions. The value of $C1$ is recommended to be in the range of 10pF to 47pF, leadless ceramic type.

PCB Layout Considerations

It is necessary to take into account a small volt drop in the PCB copper and solder joints to R_{SENSE} . Such volt drops can create noticeable error at currents of the order of 1A and greater. The PCB must be designed to provide the maximum possible copper carrying current via the sense resistor, and the traces from the S+ and S- pins must be connected only to the resistor pads. In this way, the effect of the copper is minimized.

If used, the capacitor $C1$ should be placed very close the input pins S+ and S-.

Application: High Voltage Current Monitor

The schematic of Figure 5 shows how the current monitor may be used in a high voltage application such as a TV LED backlight system. In this configuration the 500V PNP transistor $Q1$ drops a large proportion of the supply voltage. Diode $D2$ limits the differential input voltage to a safe level under overload conditions. The voltage across $U1$ is limited by the zener diode $D1$. The output current of $U1$ is limited to about 3mA by the $D2$. As R_{GAIN} is typically a few k Ω , the output voltage is therefore limited to a few volts. An additional output clamping diode may be required for higher gains. $R1$ is chosen to give a suitable bias current in $D1$ for the given supply voltage range.

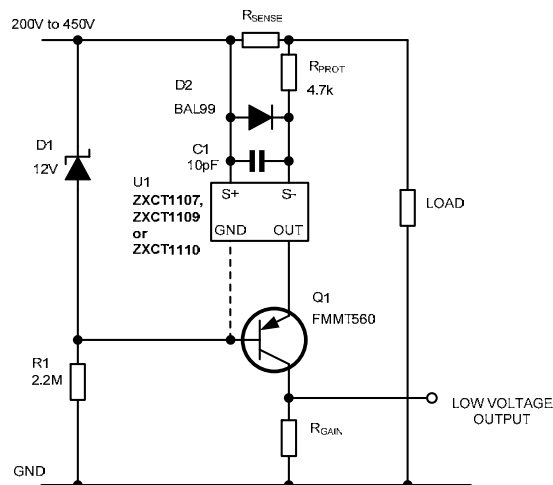

Figure 5. 450V Current Monitor

ZXCT1107/1109/1110
LOW POWER HIGH-SIDE CURRENT MONITORS

Ordering Information

Order Reference	Package	Device Marking	Reel Size	Quantity Per Reel	Tape Width (mm)
ZXCT1107SA-7	SOT23	1107	7", 180mm	3000	8
ZXCT1109SA-7	SOT23	1109	7", 180mm	3000	8
ZXCT1110W5-7	SOT25	1110	7", 180mm	3000	8

Package Outline Dimensions (All Dimensions in mm)

Package type: SOT23

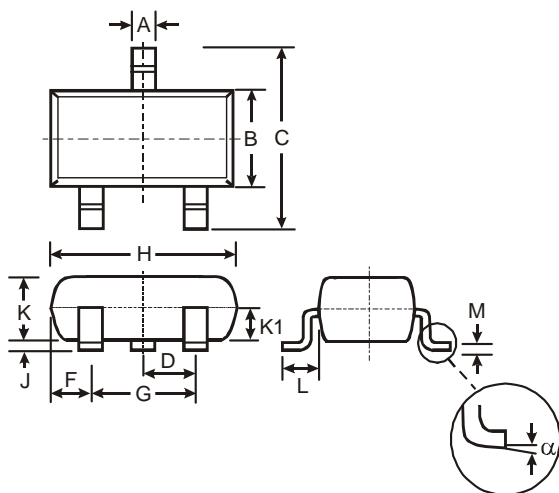

SOT23			
Dim	Min	Max	Typ
A	0.37	0.51	0.40
B	1.20	1.40	1.30
C	2.30	2.50	2.40
D	0.89	1.03	0.915
F	0.45	0.60	0.535
G	1.78	2.05	1.83
H	2.80	3.00	2.90
J	0.013	0.10	0.05
K	0.903	1.10	1.00
K1	-	-	0.400
L	0.45	0.61	0.55
M	0.085	0.18	0.11
α	0°	8°	-
All Dimensions in mm			

Package type: SOT25

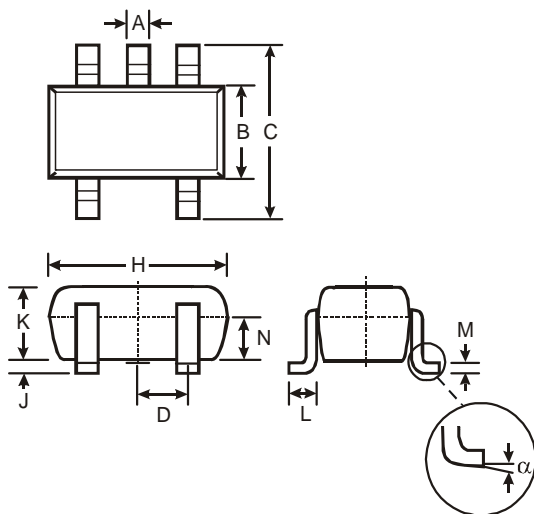

SOT25			
Dim	Min	Max	Typ
A	0.35	0.50	0.38
B	1.50	1.70	1.60
C	2.70	3.00	2.80
D	—	—	0.95
H	2.90	3.10	3.00
J	0.013	0.10	0.05
K	1.00	1.30	1.10
L	0.35	0.55	0.40
M	0.10	0.20	0.15
N	0.70	0.80	0.75
α	0°	8°	—
All Dimensions in mm			

ZXCT1107/1109/1110
LOW POWER HIGH-SIDE CURRENT MONITORS**IMPORTANT NOTICE**

DIODES INCORPORATED MAKES NO WARRANTY OF ANY KIND, EXPRESS OR IMPLIED, WITH REGARDS TO THIS DOCUMENT, INCLUDING, BUT NOT LIMITED TO, THE IMPLIED WARRANTIES OF MERCHANTABILITY AND FITNESS FOR A PARTICULAR PURPOSE (AND THEIR EQUIVALENTS UNDER THE LAWS OF ANY JURISDICTION).

Diodes Incorporated and its subsidiaries reserve the right to make modifications, enhancements, improvements, corrections or other changes without further notice to this document and any product described herein. Diodes Incorporated does not assume any liability arising out of the application or use of this document or any product described herein; neither does Diodes Incorporated convey any license under its patent or trademark rights, nor the rights of others. Any Customer or user of this document or products described herein in such applications shall assume all risks of such use and will agree to hold Diodes Incorporated and all the companies whose products are represented on Diodes Incorporated website, harmless against all damages.

Diodes Incorporated does not warrant or accept any liability whatsoever in respect of any products purchased through unauthorized sales channel.

Should Customers purchase or use Diodes Incorporated products for any unintended or unauthorized application, Customers shall indemnify and hold Diodes Incorporated and its representatives harmless against all claims, damages, expenses, and attorney fees arising out of, directly or indirectly, any claim of personal injury or death associated with such unintended or unauthorized application.

Products described herein may be covered by one or more United States, international or foreign patents pending. Product names and markings noted herein may also be covered by one or more United States, international or foreign trademarks.

LIFE SUPPORT

Diodes Incorporated products are specifically not authorized for use as critical components in life support devices or systems without the express written approval of the Chief Executive Officer of Diodes Incorporated. As used herein:

A. Life support devices or systems are devices or systems which:

1. are intended to implant into the body, or
2. support or sustain life and whose failure to perform when properly used in accordance with instructions for use provided in the labeling can be reasonably expected to result in significant injury to the user.

B. A critical component is any component in a life support device or system whose failure to perform can be reasonably expected to cause the failure of the life support device or to affect its safety or effectiveness.

Customers represent that they have all necessary expertise in the safety and regulatory ramifications of their life support devices or systems, and acknowledge and agree that they are solely responsible for all legal, regulatory and safety-related requirements concerning their products and any use of Diodes Incorporated products in such safety-critical, life support devices or systems, notwithstanding any devices- or systems-related information or support that may be provided by Diodes Incorporated. Further, Customers must fully indemnify Diodes Incorporated and its representatives against any damages arising out of the use of Diodes Incorporated products in such safety-critical, life support devices or systems.

Copyright © 2011, Diodes Incorporated

www.diodes.com



Компания «ЭлектроПласт» предлагает заключение долгосрочных отношений при поставках импортных электронных компонентов на взаимовыгодных условиях!

Наши преимущества:

- Оперативные поставки широкого спектра электронных компонентов отечественного и импортного производства напрямую от производителей и с крупнейших мировых складов;
- Поставка более 17-ти миллионов наименований электронных компонентов;
- Поставка сложных, дефицитных, либо снятых с производства позиций;
- Оперативные сроки поставки под заказ (от 5 рабочих дней);
- Экспресс доставка в любую точку России;
- Техническая поддержка проекта, помощь в подборе аналогов, поставка прототипов;
- Система менеджмента качества сертифицирована по Международному стандарту ISO 9001;
- Лицензия ФСБ на осуществление работ с использованием сведений, составляющих государственную тайну;
- Поставка специализированных компонентов (Xilinx, Altera, Analog Devices, Intersil, Interpoint, Microsemi, Aeroflex, Peregrine, Syfer, Eurofarad, Texas Instrument, Miteq, Cobham, E2V, MA-COM, Hittite, Mini-Circuits, General Dynamics и др.);

Помимо этого, одним из направлений компании «ЭлектроПласт» является направление «Источники питания». Мы предлагаем Вам помощь Конструкторского отдела:

- Подбор оптимального решения, техническое обоснование при выборе компонента;
- Подбор аналогов;
- Консультации по применению компонента;
- Поставка образцов и прототипов;
- Техническая поддержка проекта;
- Защита от снятия компонента с производства.



Как с нами связаться

Телефон: 8 (812) 309 58 32 (многоканальный)

Факс: 8 (812) 320-02-42

Электронная почта: org@eplast1.ru

Адрес: 198099, г. Санкт-Петербург, ул. Калинина, дом 2, корпус 4, литера А.