

Vertically Mounting Guard Lock Safety-door Switch Ideal for Limited Installation Space



- Selectable Operation Key insertion direction.
- Slim safety-door switch with an electromagnetic lock or unlock mechanism.
- Built-in switches with multiple-contact construction are available.
- A key holding force of 1,000 N minimum.
- Can be used for either standard loads or microloads.
- Lineup includes models with a conduit size of M20.
- Variety of Metallic Heads Available.

 Be sure to read the "Safety Precautions" on page 15 and the "Precautions for All Safety Door Switches".

Model Number Structure

Model Number Legend

Switch (Standard type)

D4GL- -

1 2 3 4 5 6

- Conduit Size**
 - 1: Pg13.5
 - 2: G1/2
 - 4: M20
- Built-in Switch (with Door Open/Closed Detection Switch and Lock Monitor Switch Contacts)**
 - A: 1NC/1NO (slow-action contacts) + 1NC/1NO (slow-action contacts)
 - B: 1NC/1NO (slow-action contacts) + 2NC (slow-action contacts)
 - C: 2NC (slow-action contacts) + 1NC/1NO (slow-action contacts)
 - D: 2NC (slow-action contacts) + 2NC (slow-action contacts)
 - E: 2NC/1NO (slow-action contacts) + 1NC/1NO (slow-action contacts)
 - F: 2NC/1NO (slow-action contacts) + 2NC (slow-action contacts)
 - G: 3NC (slow-action contacts) + 1NC/1NO (slow-action contacts)
 - H: 3NC (slow-action contacts) + 2NC (slow-action contacts)
- Head Mounting Direction and Material**
 - F: Four mounting directions possible (Front-side mounting at shipping)/plastic
 - D: Four mounting directions possible (Front-side mounting at shipping)/metal
- Door Lock and Release**
 - A: Mechanical lock/24 VDC solenoid release
 - G: 24 VDC solenoid lock/mechanical release
- Indicator**
 - A: 24 VDC (orange/green LED indicator)
- Release Key Type**
 - Blank: Standard release key (resin)
 - 4: Special release key (resin)
(Note: Release keys are provided.)

Switch (Metallic release key type)

D4GL- - -SJ

1 2 3 4 5 6

- Conduit Size**
 - 2: G1/2 (1-conduit)
 - 4: M20 (1-conduit)
- Built-in Switch**
 - A: 1NC/1NO + 1NC/1NO
 - B: 1NC/1NO + 2NC
 - C: 2NC + 1NC/1NO
 - D: 2NC + 2NC
 - E: 2NC/1NO + 1NC/1NO
 - F: 2NC/1NO + 2NC
 - G: 3NC + 1NC/1NO
 - H: 3NC + 2NC
- Head Material**
 - F: resin
- Door Lock and Release**
 - A: Mechanical lock/24 VDC solenoid release
 - G: 24 VDC solenoid lock/ mechanical release
- Indicator**
 - A: 24 VDC (orange/green LED indicator)

Note: The wiring specification is different from the wiring specification for the standard type.
Please refer to the "Connection" section for details.
- Release Key Type**
 - Blank: Standard release key (metal)

Operation Key

D4DS-K

1

- Operation Key Type**
 - 1: Horizontal mounting
 - 2: Vertical mounting
 - 3: Adjustable mounting (horizontal)
 - 5: Adjustable mounting (horizontal/vertical)

Ordering Information

List of Models

Switches (Operation Keys are sold separately.)

■ : Models with certified direct opening contacts.

Consult with your OMRON representative when ordering any models that are not listed in this table.

Head material	Release key type	Solenoid voltage/ indicator	Lock and release types	Contact configuration (door open/closed detection switch and lock monitor switch contacts) (slow-action) Certified direct opening NC contact	Conduit size	Model
Plastic	Standard (resin)	Solenoid: 24 VDC Orange/green LED: 24 VDC	Mechanical lock Solenoid release	1NC/1NO+1NC/1NO	Pg13.5	D4GL-1AFA-A
					G1/2	D4GL-2AFA-A *
					M20	D4GL-4AFA-A
				1NC/1NO+2NC	Pg13.5	D4GL-1BFA-A
					G1/2	D4GL-2BFA-A
					M20	D4GL-4BFA-A
				2NC+1NC/1NO	Pg13.5	D4GL-1CFA-A
					G1/2	D4GL-2CFA-A
					M20	D4GL-4CFA-A
				2NC+2NC	Pg13.5	D4GL-1DFA-A
					G1/2	D4GL-2DFA-A *
					M20	D4GL-4DFA-A
				2NC/1NO+1NC/1NO	Pg13.5	D4GL-1EFA-A
					G1/2	D4GL-2EFA-A
					M20	D4GL-4EFA-A
				2NC/1NO+2NC	Pg13.5	D4GL-1FFA-A
					G1/2	D4GL-2FFA-A *
					M20	D4GL-4FFA-A
				3NC+1NC/1NO	Pg13.5	D4GL-1GFA-A
					G1/2	D4GL-2GFA-A
					M20	D4GL-4GFA-A
				3NC+2NC	Pg13.5	D4GL-1HFA-A
					G1/2	D4GL-2HFA-A *
					M20	D4GL-4HFA-A
			Solenoid lock Mechanical release	1NC/1NO+1NC/1NO	Pg13.5	D4GL-1AFG-A
					G1/2	D4GL-2AFG-A *
					M20	D4GL-4AFG-A
				1NC/1NO+2NC	Pg13.5	D4GL-1BFG-A
					G1/2	D4GL-2BFG-A
					M20	D4GL-4BFG-A
				2NC+1NC/1NO	Pg13.5	D4GL-1CFG-A
					G1/2	D4GL-2CFG-A
					M20	D4GL-4CFG-A
				2NC+2NC	Pg13.5	D4GL-1DFG-A
					G1/2	D4GL-2DFG-A *
					M20	D4GL-4DFG-A
				2NC/1NO+1NC/1NO	Pg13.5	D4GL-1EFG-A
					G1/2	D4GL-2EFG-A
					M20	D4GL-4EFG-A
				2NC/1NO+2NC	Pg13.5	D4GL-1FFG-A
					G1/2	D4GL-2FFG-A *
					M20	D4GL-4FFG-A
				3NC+1NC/1NO	Pg13.5	D4GL-1GFG-A
					G1/2	D4GL-2GFG-A
					M20	D4GL-4GFG-A
				3NC+2NC	Pg13.5	D4GL-1HFG-A
					G1/2	D4GL-2HFG-A *
					M20	D4GL-4HFG-A



* Models with Korean S-mark certification.

Head material	Release key type	Solenoid voltage/ indicator	Lock and release types	Contact configuration (door open/closed detection switch and lock monitor switch contacts) (slow-action) Certified direct opening NC contact	Conduit size	Model
Plastic	Special release key (resin)	Solenoid: 24 VDC Orange/green LED: 24 VDC	Mechanical lock Solenoid release	1NC/1NO+1NC/1NO	Pg13.5	D4GL-1AFA-A4
					G1/2	D4GL-2AFA-A4
					M20	D4GL-4AFA-A4
				1NC/1NO+2NC	Pg13.5	D4GL-1BFA-A4
					G1/2	D4GL-2BFA-A4
					M20	D4GL-4BFA-A4
				2NC+1NC/1NO	Pg13.5	D4GL-1CFA-A4
					G1/2	D4GL-2CFA-A4
					M20	D4GL-4CFA-A4
				2NC+2NC	Pg13.5	D4GL-1DFA-A4
					G1/2	D4GL-2DFA-A4
					M20	D4GL-4DFA-A4
				2NC/1NO+1NC/1NO	Pg13.5	D4GL-1EFA-A4
					G1/2	D4GL-2EFA-A4
					M20	D4GL-4EFA-A4
				2NC/1NO+2NC	Pg13.5	D4GL-1FFA-A4
					G1/2	D4GL-2FFA-A4
					M20	D4GL-4FFA-A4
				3NC+1NC/1NO	Pg13.5	D4GL-1GFA-A4
					G1/2	D4GL-2GFA-A4
					M20	D4GL-4GFA-A4
				3NC+2NC	Pg13.5	D4GL-1HFA-A4
					G1/2	D4GL-2HFA-A4
					M20	D4GL-4HFA-A4
			Solenoid lock Mechanical release	1NC/1NO+1NC/1NO	Pg13.5	D4GL-1AFG-A4
					G1/2	D4GL-2AFG-A4
					M20	D4GL-4AFG-A4
				1NC/1NO+2NC	Pg13.5	D4GL-1BFG-A4
					G1/2	D4GL-2BFG-A4
					M20	D4GL-4BFG-A4
				2NC+1NC/1NO	Pg13.5	D4GL-1CFG-A4
					G1/2	D4GL-2CFG-A4
					M20	D4GL-4CFG-A4
				2NC+2NC	Pg13.5	D4GL-1DFG-A4
					G1/2	D4GL-2DFG-A4
					M20	D4GL-4DFG-A4
				2NC/1NO+1NC/1NO	Pg13.5	D4GL-1EFG-A4
					G1/2	D4GL-2EFG-A4
					M20	D4GL-4EFG-A4
				2NC/1NO+2NC	Pg13.5	D4GL-1FFG-A4
					G1/2	D4GL-2FFG-A4
					M20	D4GL-4FFG-A4
				3NC+1NC/1NO	Pg13.5	D4GL-1GFG-A4
					G1/2	D4GL-2GFG-A4
					M20	D4GL-4GFG-A4
				3NC+2NC	Pg13.5	D4GL-1HFG-A4
					G1/2	D4GL-2HFG-A4
					M20	D4GL-4HFG-A4

Head material	Release key type	Solenoid voltage/ indicator	Lock and release types	Contact configuration (door open/closed detection switch and lock monitor switch contacts)	Conduit size	Model
Plastic	Standard (metal)	Solenoid: 24 VDC Orange/green LED: 24 VDC	Mechanical lock Solenoid release	1NC/1NO+1NC/1NO	G1/2	D4GL-2AFA-A-SJ *
					M20	D4GL-4AFA-A-SJ *
				1NC/1NO+2NC	G1/2	D4GL-2BFA-A-SJ *
					M20	D4GL-4BFA-A-SJ *
				2NC+1NC/1NO	G1/2	D4GL-2CFA-A-SJ *
					M20	D4GL-4CFA-A-SJ *
				2NC+2NC	G1/2	D4GL-2DFA-A-SJ *
					M20	D4GL-4DFA-A-SJ *
				2NC/1NO+1NC/1NO	G1/2	D4GL-2EFA-A-SJ *
					M20	D4GL-4EFA-A-SJ *
				2NC/1NO+2NC	G1/2	D4GL-2FFA-A-SJ *
					M20	D4GL-4FFA-A-SJ *
				3NC+1NC/1NO	G1/2	D4GL-2GFA-A-SJ *
					M20	D4GL-4GFA-A-SJ *
			3NC+2NC	G1/2	D4GL-2HFA-A-SJ *	
				M20	D4GL-4HFA-A-SJ *	
			Solenoid lock Mechanical release	1NC/1NO+1NC/1NO	G1/2	D4GL-2AFG-A-SJ *
					M20	D4GL-4AFG-A-SJ *
				1NC/1NO+2NC	G1/2	D4GL-2BFG-A-SJ *
					M20	D4GL-4BFG-A-SJ *
				2NC+1NC/1NO	G1/2	D4GL-2CFG-A-SJ *
					M20	D4GL-4CFG-A-SJ *
				2NC+2NC	G1/2	D4GL-2DFG-A-SJ *
					M20	D4GL-4DFG-A-SJ *
				2NC/1NO+1NC/1NO	G1/2	D4GL-2EFG-A-SJ *
					M20	D4GL-4EFG-A-SJ *
				2NC/1NO+2NC	G1/2	D4GL-2FFG-A-SJ *
					M20	D4GL-4FFG-A-SJ *
3NC+1NC/1NO	G1/2	D4GL-2GFG-A-SJ *				
	M20	D4GL-4GFG-A-SJ *				
3NC+2NC	G1/2	D4GL-2HFG-A-SJ *				
	M20	D4GL-4HFG-A-SJ *				

* These models will receive Korean S-mark certification.

Operation Keys

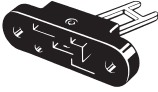
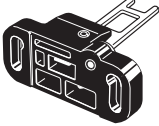
Type	Model
Horizontal mounting 	D4DS-K1
Vertical mounting 	D4DS-K2
Adjustable mounting (Horizontal) 	D4DS-K3
Adjustable mounting (Horizontal/Vertical) 	D4DS-K5

Specifications

Standards and EC Directives

Conforms to the following EC Directives:

- Machinery Directive
- Low Voltage Directive
- EN1088
- EN60204-1
- GS-ET-19

Certified Standards

Certification body	Standard	File No.
TÜV SÜD	EN60947-5-1 (certified direct opening)	Consult your OMRON representative for details.
UL *1	UL508, CSA C22.2 No. 14	E76675
CQC (CCC)	GB14048.5	2003010305064264
KOSHA *2	EN 60947-5-1	2007-26

*1. Certification for CSA C22.2 No. 14 is authorized by the UL mark.
*2. Only certain models have been certified.

Certified Standard Ratings

TÜV (EN60947-5-1), CCC (GB14048.5)

Item	Utilization category	AC-15	DC-13
Rated operating current (I _e)		0.75 A	0.27 A
Rated operating voltage (U _e)		240 V	250 V

Note: Use a 10 A fuse type gI or gG that conforms to IEC60269 as a short-circuit protection device.

UL/CSA (UL508, CSA C22.2 No. 14)

C300

Rated voltage	Carry current	Current (A)		Volt-amperes (VA)	
		Make	Break	Make	Break
120 VAC	2.5 A	15	1.5	1,800	180
240 VAC		7.5	0.75		

Q300

Rated voltage	Carry current	Current (A)		Volt-amperes (VA)	
		Make	Break	Make	Break
125 VAC	2.5 A	0.55	0.55	69	69
250 VAC		0.27	0.27		

Solenoid Coil Characteristics

Item	Type	24 VDC
Rated operating voltage (100% ED)		24 VDC ±10%
Current consumption		Approx. 200 mA
Insulation		Class B (130°C max.)

Indicator Characteristics

Item	Type	LED
Rated voltage		24 VDC
Current leakage		Approx. 3 mA
Color (LED)		Orange/Green

Characteristics

Degree of protection *1		IP67 (EN60947-5-1)
Durability *2	Mechanical	1,000,000 operations min.
	Electrical	500,000 operations min. (4 mA resistive load at 24 VDC) 150,000 operations min. (1 A resistive load at 125 VAC, 2 circuits/4 mA resistive load at 24 VDC, 2 circuits) *3
Operating speed		0.05 to 0.5 m/s
Operating frequency		30 operations/minute max.
Direct opening force *4		60 N min. (EN60947-5-1)
Direct opening travel *4		10 mm min. (EN60947-5-1)
Holding force *5		1,000 N min.
Contact resistance		100 mΩ max.
Minimum applicable load *6		4 mA resistive load at 24 VDC (N-level reference value)
Rated insulation voltage (U_i)		300 V (EN60947-5-1)
Rated frequency		50/60 Hz
Protection against electric shock		Class II (double insulation)
Pollution degree (operating environment)		3 (EN60947-5-1)
Impulse withstand voltage (EN60947-5-1)	Between terminals of same polarity	2.5 kV
	Between terminals of different polarity	4 kV
	Between solenoid and non-current carrying metallic parts	0.8 kV
	Between other terminals and non-current carrying metallic parts	4 kV
Insulation resistance		100 MΩ min. (at 500 VDC)
Contact gap		2 × 2 mm min.
Vibration resistance	Malfunction	10 to 55 Hz, 0.75 mm single amplitude
Shock resistance	Destruction	1,000 m/s ² min.
	Malfunction	300 m/s ² min.
Conditional short-circuit current		100 A (EN60947-5-1)
Conventional free air thermal current (I_{th})		2.5 A (EN60947-5-1)
Ambient operations temperature		-10 to 55°C (with no icing)
Ambient operations humidity		95% max.
Weight		Approx. 400 g (D4GL-1AFA-A)

Note: 1. The above values are initial values.

2. The Switch contacts can be used with either standard loads or microloads. Once the contacts have been used to switch a load, however, they cannot be used to switch smaller loads. The contact surfaces will become rough once they have been used and contact reliability for smaller loads may be reduced.

***1.** The degree of protection is tested using the method specified by the standard (EN60947-5-1). Confirm that sealing properties are sufficient for the operating conditions and environment beforehand. Although the switch box is protected from dust or water penetration, do not use the D4GL in places where foreign material may enter through the key hole on the head, otherwise Switch damage or malfunctioning may occur.

***2.** The durability is for an ambient temperature of 5 to 35°C and an ambient humidity of 40% to 70%. For more details, consult your OMRON representative.

***3.** Do not pass the 1 A, 125 VAC load through more than 2 circuits.

***4.** These figures are minimum requirements for safe operation.

***5.** This figure is based on the GS-ET-19 evaluation method.

***6.** This value will vary with the switching frequency, environment, and reliability level. Confirm that correct operation is possible with the actual load beforehand.

Connections

Internal Circuit Diagram Indicator

D4GL-□□□□-□□

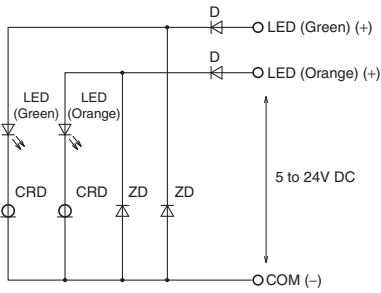

Solenoid

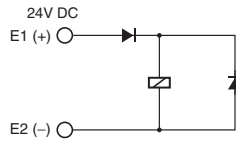

D4GL-□□□□-□□-**SJ**

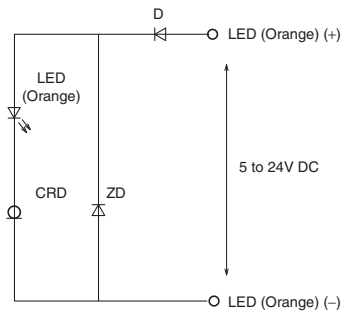
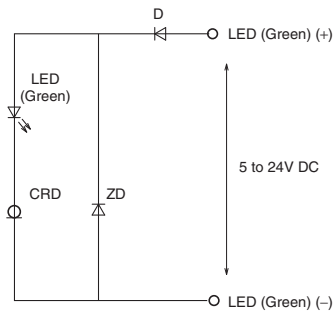

Connection Example for D4GL-1HFA-A

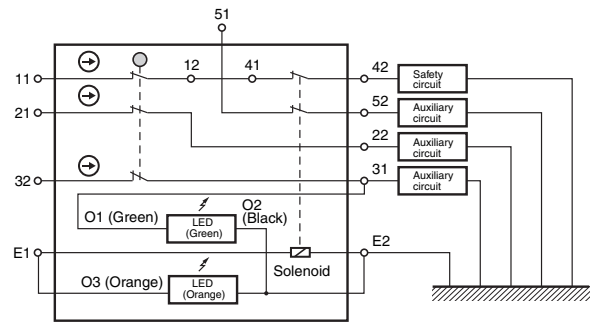

- Direct opening contacts used as safety-circuit input are indicated with the mark. Terminals 11 and 12 and terminals 21 and 22 are direct opening contacts.
- Connect the indicators in parallel to the auxiliary circuits or terminals E1 and E2.
- Although the 3 lines are connected at the time of delivery, rewire them as necessary for the application.

<D4GL-□□□□-□□>

Indicator	Terminal number	Lead wire color	Connected terminal *
Green indicator (+)	01	Green	31
Orange indicator (+)	03	Orange	E1
Common (-)	02	Black	E2

<D4GL-□□□□-□□-**SJ**>

Indicator	Terminal number	Lead wire color	Connected terminal *
Green indicator (+)	01	Green	31
Green indicator (-)	04	White	-
Orange indicator (+)	03	Orange	E1
Orange indicator (-)	05	Black	E2

* The terminal number of green indicator will be different according to the contact configuration.

Circuit Connection Example

- Terminals 12 and 41 are connected internally and so connect terminals 11 and 42 for safety-circuit input. (BIA GS-ET-19)
- Connect terminals 21 and 22 and terminals 51 and 52 in series when using as safety-circuit input (redundancy circuit for terminals 11 and 12 and terminals 41 and 42 above). Connect the terminals individually when using as auxiliary-circuit input (e.g., terminals 21 and 22 for safety-door open/closed monitoring and terminals 51 and 52 for monitoring the lock status).
- In the following connection example, terminals 21 and 22 and terminals 51 and 52 are used as auxiliary-circuit input. In this case, the green indicator lights when the door is closed and the orange indicator lights when the solenoid turns ON.

D4GL-□□□□-□□

- "2" : A, B, E, or F =33
- "2" : C or D =21
- "2" : G or H =31

- If an indicator is connected in parallel to a direct opening contact, when the indicator breaks, a short-circuit current will be generated, possibly resulting in an installation malfunction.
- Do not switch circuits for two or more standard loads at the same time. Doing so may adversely affect insulation performance.
- DC solenoids have polarity. Confirm terminal polarity before wiring.

Operation Method

Operation Principles

<p>Mechanical lock models</p>			<p>The solenoid is released only when the lock is turned ON.</p>
<p>Solenoid lock models</p>		<p>If the solenoid is OFF, the door will not be locked when it is closed. This means that the door can be opened and closed easily when replacing workpieces or parts.</p>	<p>The door is locked only when the solenoid is turned ON. This means that the door will be unlocked if there is a power interruption and so this model cannot be used in systems that would maintain a hazardous state (e.g., systems requiring toxic gases, high temperatures, or gears that would continue to turn due to inertia).</p>

Structure and Nomenclature

Structure

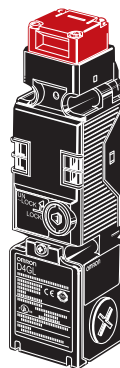
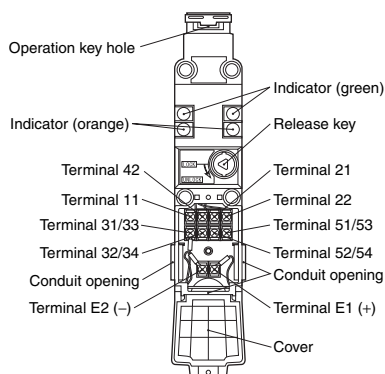

Note: Terminal numbers vary with the model. Confirm terminal numbers by referring to the cover on the back of the Switch.

Contact Form

Indicates conditions where the Key is inserted and the lock is applied. Terminals 12 and 41 are connected internally (as per BIA GS-ET-19).

Model	Contact (door open/closed detection and lock monitor)	Contact form		Operating pattern	Remarks
		Door open/closed detection	Lock monitor		
D4GL-□AF□-□	1NC/1NO + 1NC/1NO				Only NC contact 11-12 has a certified direct opening mechanism. (→) The terminals 11-42, 33-34, and 53-54 can be used as unlike poles.
D4GL-□BF□-□	1NC/1NO + 2NC				Only NC contact 11-12, has a certified direct opening mechanism. (→) The terminals 11-42, 33-34, and 51-52 can be used as unlike poles.
D4GL-□CF□-□	2NC + 1NC/1NO				Only NC contacts 11-12 and 21-22 have a certified direct opening mechanism. (→) The terminals 11-42, 21-22, and 53-54 can be used as unlike poles.
D4GL-□DF□-□	2NC + 2NC				Only NC contacts 11-12 and 21-22 have a certified direct opening mechanism. (→) The terminals 11-42, 21-22, and 51-52 can be used as unlike poles.
D4GL-□EF□-□	2NC/1NO + 1NC/1NO				Only NC contacts 11-12 and 21-22 have a certified direct opening mechanism. (→) The terminals 11-42, 21-22, 33-34, and 53-54 can be used as unlike poles.
D4GL-□FF□-□	2NC/1NO + 2NC				Only NC contacts 11-12 and 21-22 have a certified direct opening mechanism. (→) The terminals 11-42, 21-22, 33-34, and 51-52 can be used as unlike poles.
D4GL-□GF□-□	3NC + 1NC/1NO				Only NC contacts 11-12, 21-22, and 31-32 have a certified direct opening mechanism. (→) The terminals 11-42, 21-22, 31-32, and 53-54 can be used as unlike poles.
D4GL-□HF□-□	3NC + 2NC				Only NC contacts 11-12, 21-22, and 31-32 have a certified direct opening mechanism. (→) The terminals 11-42, 21-22, 31-32, and 51-52 can be used as unlike poles.

Dimensions

Dimensions and Operating Characteristics Switches

D4GL-□□□□-A

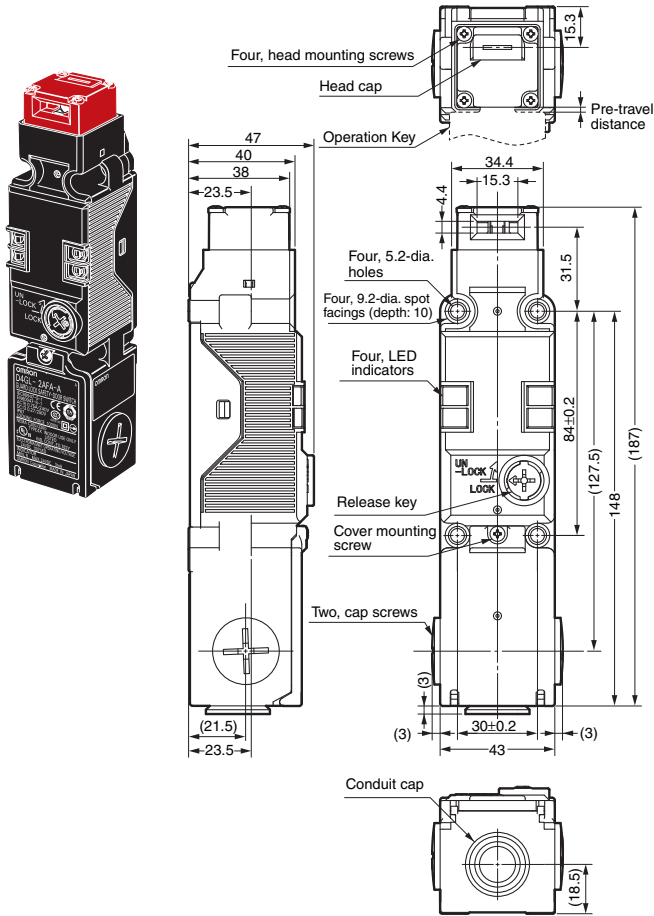

Operating characteristics	Model	D4GL-□□□□-A
Key insertion force		15 N max.
Key extraction force		40 N max.
Pre-travel distance		10 mm max.
Movement before being locked		4 mm min.

D4GL-□□□□-A4

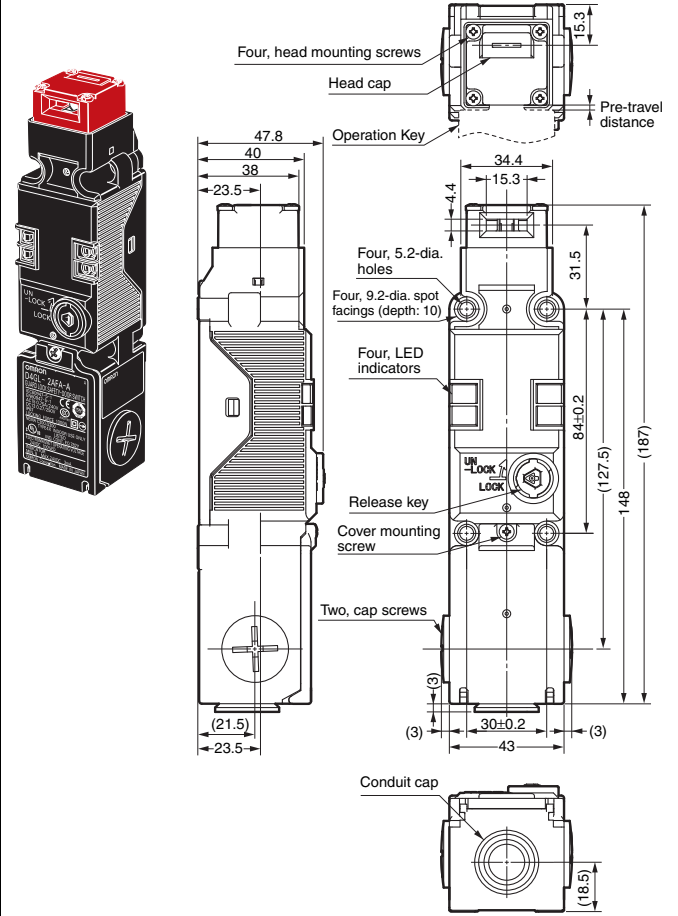

Operating characteristics	Model	D4GL-□□□□-A4
Key insertion force		15 N max.
Key extraction force		40 N max.
Pre-travel distance		10 mm max.
Movement before being locked		4 mm min.

Operation Keys

D4DS-K1

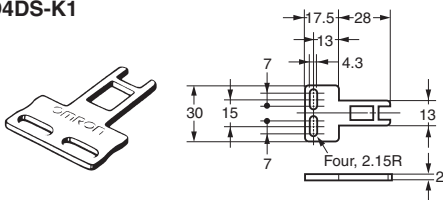

D4DS-K3

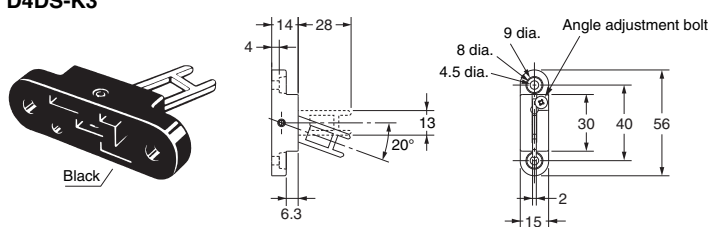

D4DS-K2

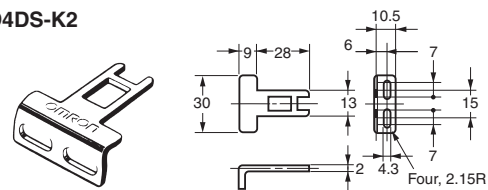

D4DS-K5

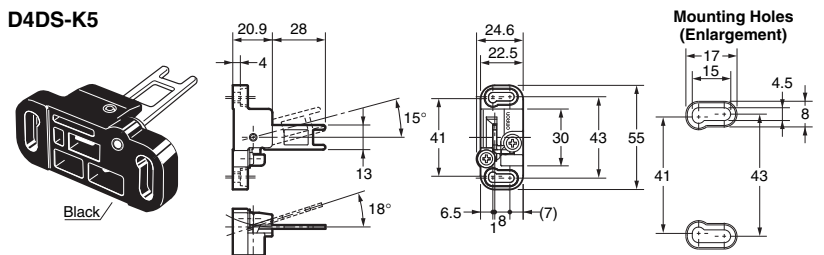

Note: Unless otherwise specified, a tolerance of ±0.4 mm applies to all dimensions.

With Operation Key Inserted

D4GL + D4DS-K1
(with Front-inserted Operation Key)

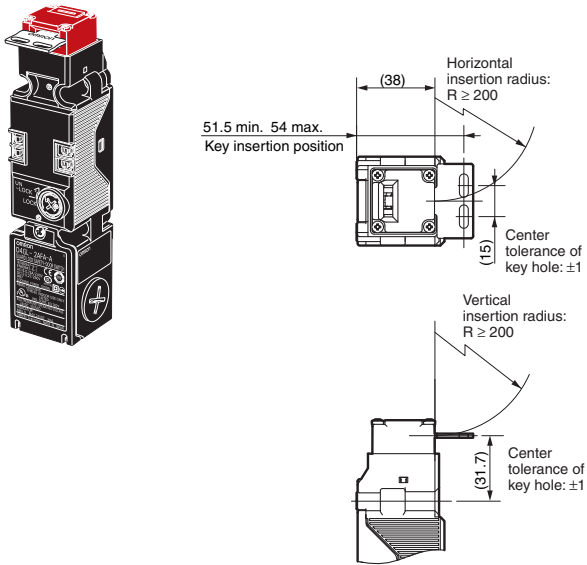

D4GL + D4DS-K1
(with Top-inserted Operation Key)

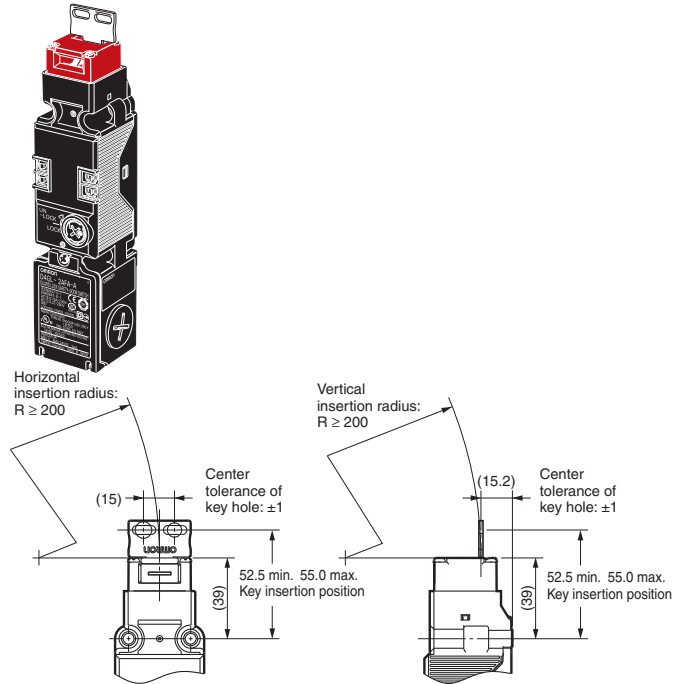

D4GL + D4DS-K2
(with Front-inserted Operation Key)

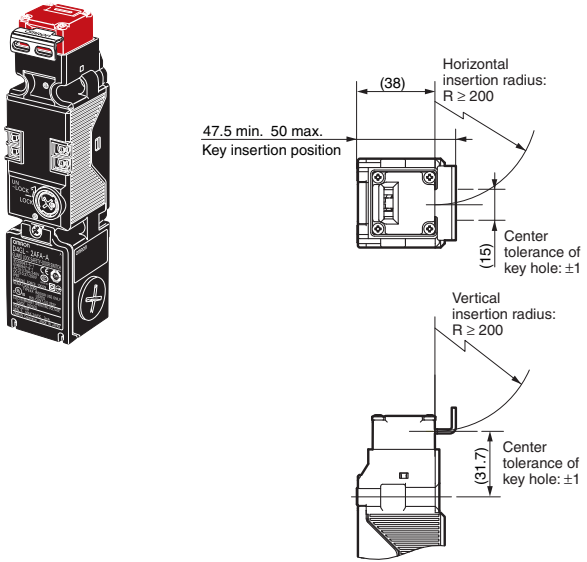

D4GL + D4DS-K2
(with Top-inserted Operation Key)

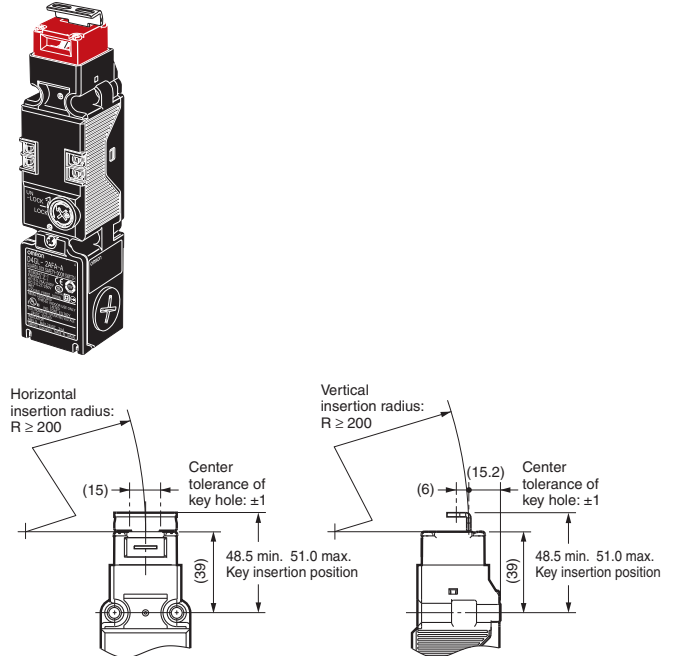

D4GL + D4DS-K3
(with Front-inserted Operation Key)

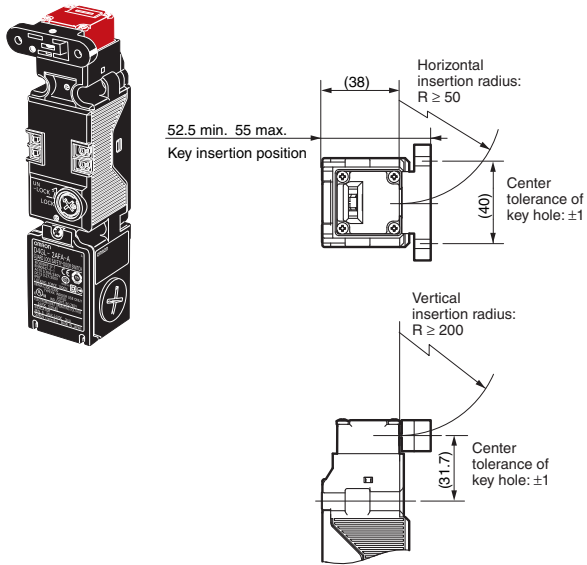

D4GL + D4DS-K3
(with Top-inserted Operation Key)

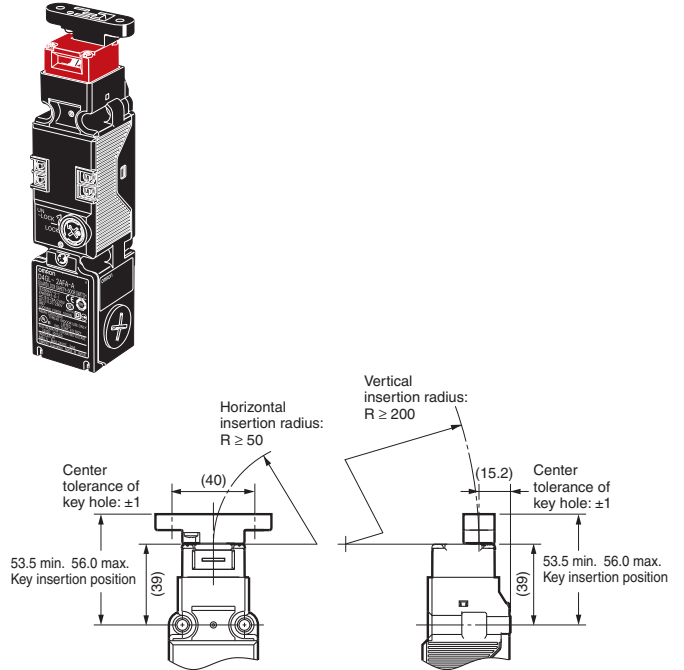

D4GL + D4DS-K5
(with Front-inserted Operation Key)

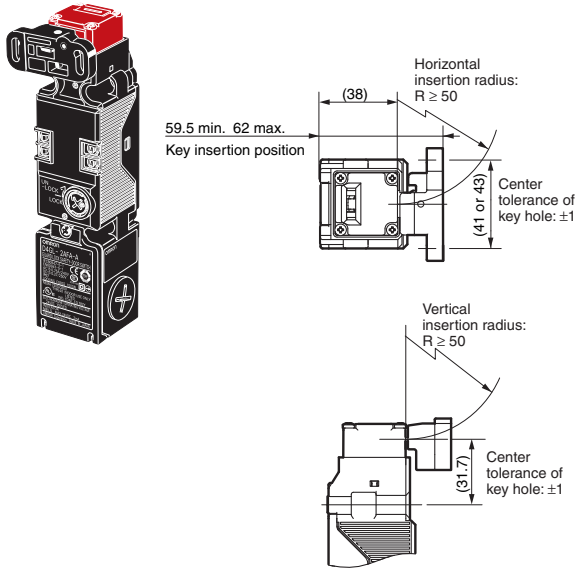

D4GL + D4DS-K5
(with Top-inserted Operation Key)

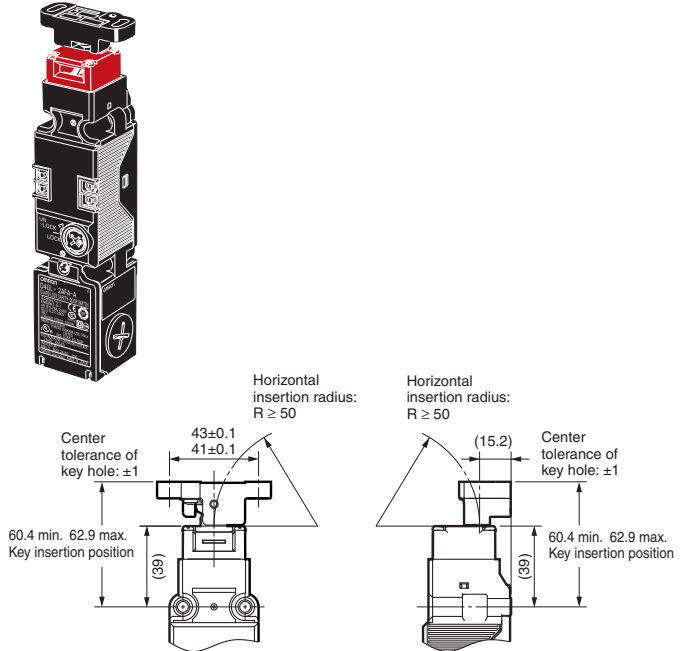

Application Examples

G9SA-321-T + D4GL-□AFA-□ (Mechanical Lock Type) Circuit Diagram (Manual Reset)

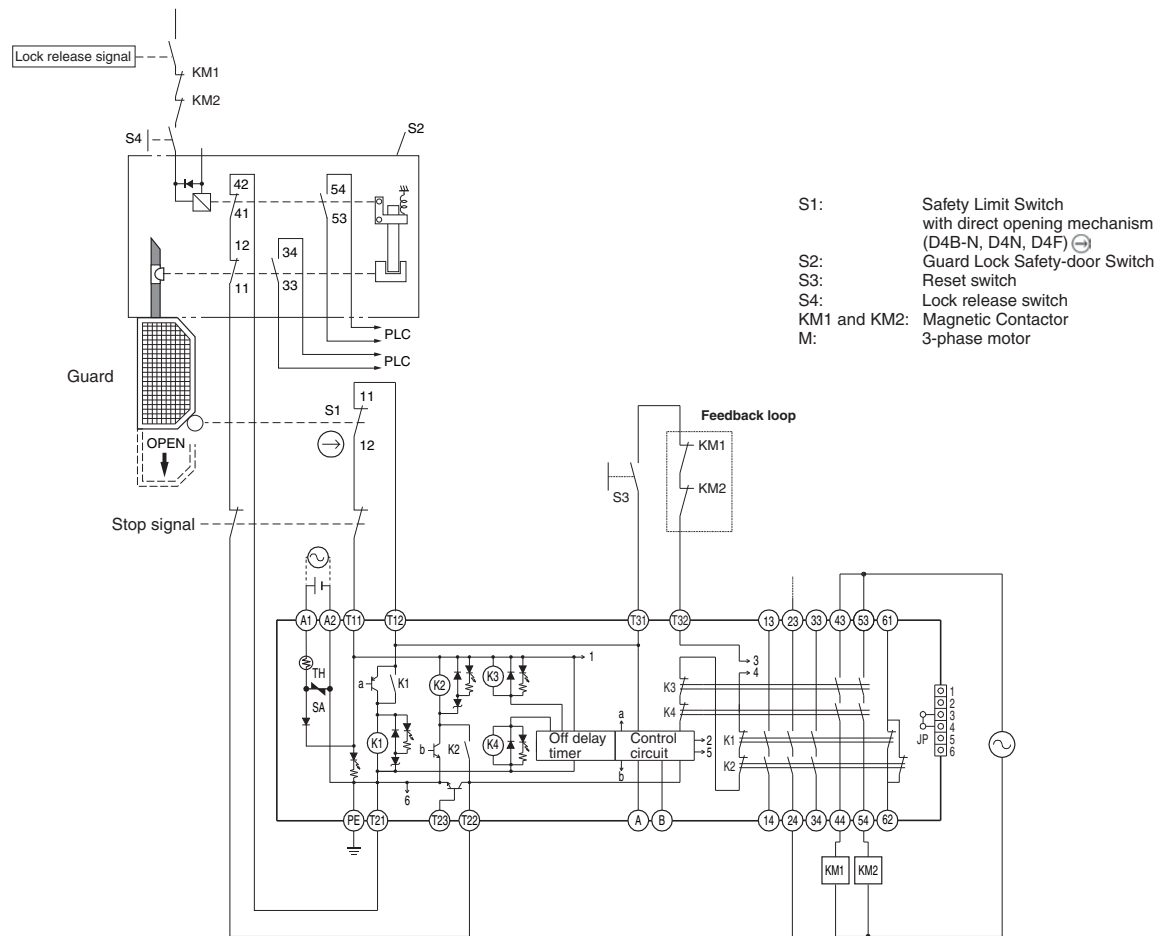

- S1: Safety Limit Switch with direct opening mechanism (D4B-N, D4N, D4F)
- S2: Guard Lock Safety-door Switch
- S3: Reset switch
- S4: Lock release switch
- KM1 and KM2: Magnetic Contactor
- M: 3-phase motor

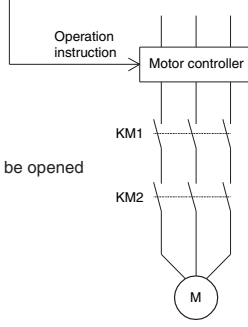
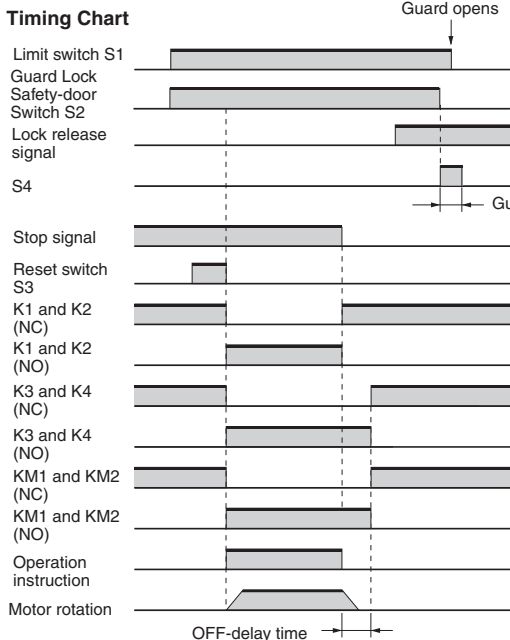

Note: The above circuit diagram is for Category 3.

G9SA-301 (24 VAC/VDC) + D4GL-□AFG-□ (Solenoid Lock Type) Circuit Diagram (Auto-reset)

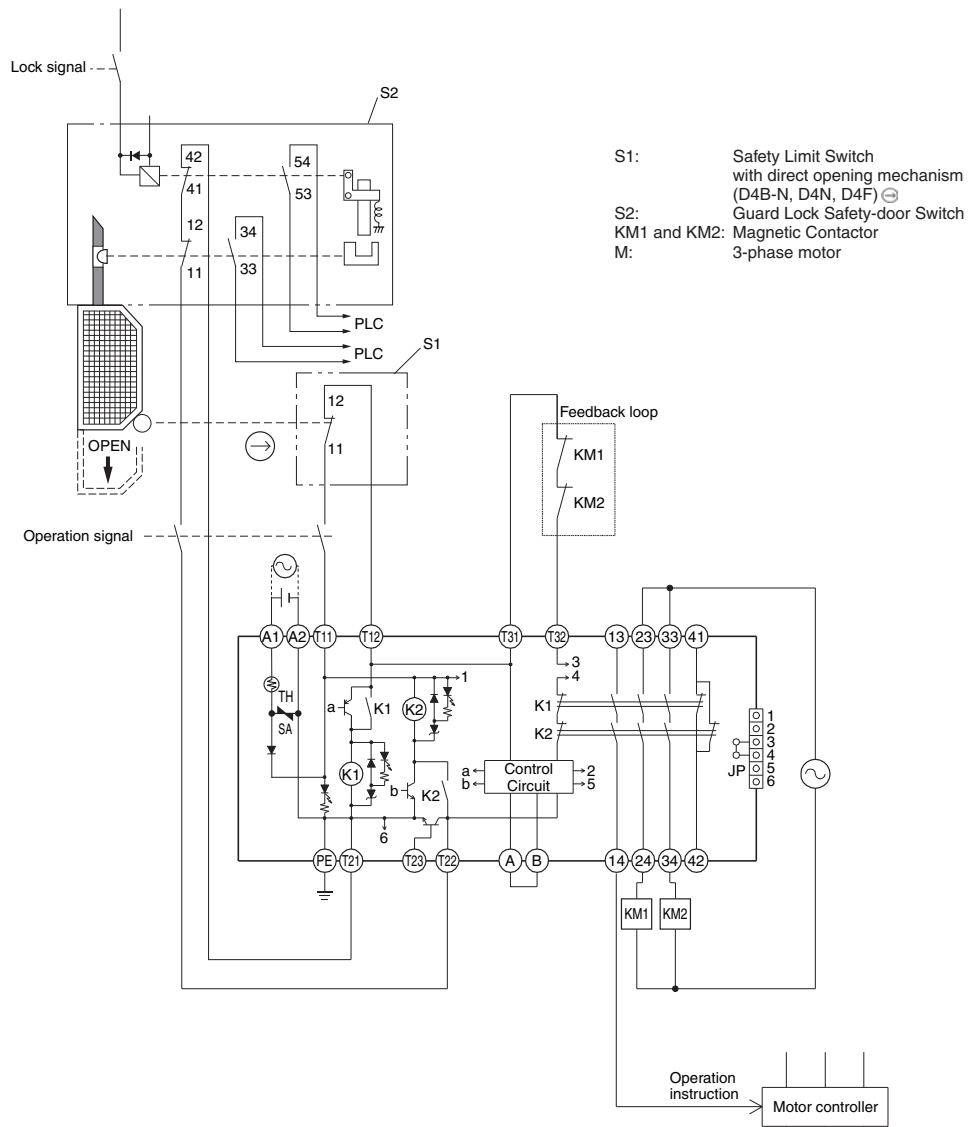

S1: Safety Limit Switch with direct opening mechanism (D4B-N, D4N, D4F) ⊕
 S2: Guard Lock Safety-door Switch
 KM1 and KM2: Magnetic Contactor
 M: 3-phase motor

Timing Chart

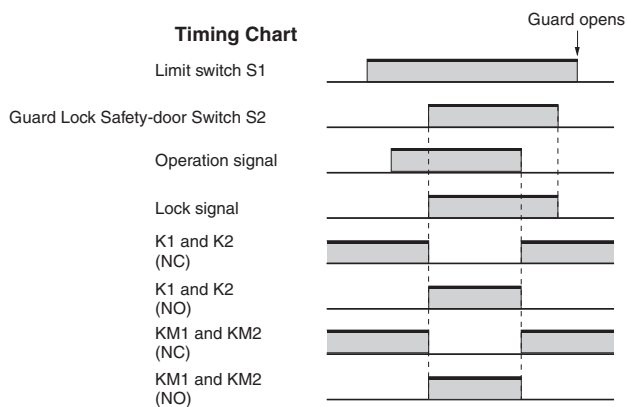

Note: 1. This circuit diagram is for Category 4.
2. The lock can be released at any time. Therefore, do not use a model with a solenoid lock in applications where the operator may be exposed to danger when the guard opens. Use a model with a mechanical lock.

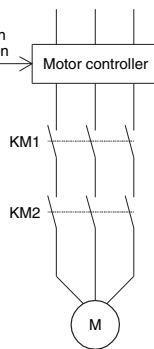

Safety Precautions

Refer to the “*Precautions for All Switches*” and “*Precautions for All Safety Door Switches*”.

⚠ DANGER

Injury may occasionally occur. Always check to make sure that the safety functions operate correctly before using the machine. The safety functions may not operate correctly because of wiring mistakes, setting mistakes, or Switch malfunction, causing some machines to continue operating in situations where they should be stopped.



Injury may occasionally occur. If the machine is used with the release key in the UNLOCK position, the electromagnetic lock may not operate, causing some machines to continue operating in situations where they should be stopped. Be sure to put the release key in the LOCK position before using the machine. Also, check the condition of the lock and safety circuits.



Injury may occasionally occur. Always ensure that the release key is set to "UNLOCK" or that the Operation Key is inserted before changing the direction of the head. Not doing so may damage the Switch, causing some machines to continue operating in situations where they should be stopped. Refer to “Release Key” on page 15.



Injury may occasionally occur. When the electromagnetic lock function or Switch function is damaged, some machines may continue operating in situations where they should be stopped. Do not use the electromagnetic lock function of the Switch in place of a door lock. Always provide a lock separate from the Switch, attach a warning seal to prevent people from using excessive force to open the door when it is locked, or provide an indicator lamp to show the locked/unlocked status of the door.



⚠ CAUTION

Electric shock may occasionally occur. Do not use metal connectors or metal conduits.



Precautions for Safe Use

Installation Environment

- Do not use the Switch submerged in oil or water or in locations continuously subject to splashes of oil or water. Doing so may result in oil or water entering the Switch. (The IP67 degree of protection of the Switch specifies the amount of water penetration after the Switch is submerged in water for a certain period of time.)

Wiring

- Do not switch circuits for two or more standard loads (125 VAC, 1 A). Doing so may adversely affect insulation performance.
- Always attach the cover after completing wiring and before using the Switch. Do not supply power when the cover is not attached. Electric shock may occur if the Switch is used without the cover attached.

Installation

- Make sure the Switch is mounted securely to prevent it from falling off. Otherwise injury may result.
- Do not use a Switch as a stopper.
- Be sure to install a stopper as shown in the following illustration when mounting the Switch and adjust the stopper so that the Operation Key is within the setting zone. (Setting zone: 0.5 to 3.0 mm)

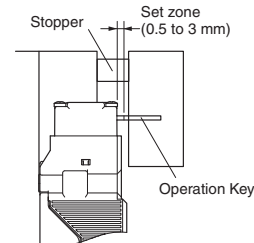

- Do not subject the Switch to a shock that exceeds the Switch's shock resistance of 1,000 m/s².

Precautions for Correct Use

The Switch contacts can be used with either standard loads or microloads. Once the contacts have been used to switch a load, however, they cannot be used to switch smaller loads. The contact surfaces will become rough once they have been used and contact reliability for smaller loads may be reduced.

Release Key

- The release key is used to unlock the Switch in case of emergency or if the power supply to the Switch stops.
- If the release key setting is changed from LOCK to UNLOCK, the lock will be released and the safety door can be opened (mechanical lock models only).
- After setting the release key to UNLOCK to, for example, perform maintenance, be sure to return it to LOCK setting before resuming operation.
- Do not use the release key to start or stop machines.
- The auxiliary lock must be released only by authorized personnel.
- Do not impose a force exceeding 0.5 N·m on the release key screws. The release key may be damaged and may not operate properly.
- The release key is set in the unlock position at the factory for the D4GL-□□□A and to the lock position for the D4GL-□□□G.
- To prevent the release key from being used by unauthorized personnel, set it to LOCK and seal it with sealing wax.

Figure 1

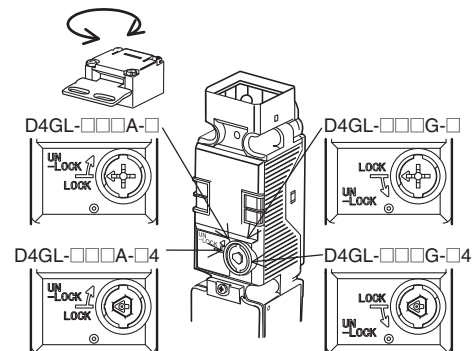

Hinged Door

If the Switch is mounted too close to the hinge, the force imposed on the lock will be much larger than for locations far from the hinge and the lock may be damaged. Mount the Switch close to the handle.

Solenoid Lock Models

The solenoid lock locks the door only when power is supplied to the solenoid. Therefore, the door will be unlocked if the power supply to the solenoid stops. Therefore, do not use solenoid lock models for machines that may be operating and dangerous even after the machine stops operating.

Mounting

Appropriate Tightening Torque

- Be sure to tighten each screw of the Switch properly. Loose screws may result in malfunction.

Terminal screw	0.4 to 0.5 N·m
Cover mounting screw	0.5 to 0.7 N·m
Head mounting screw	0.5 to 0.6 N·m
Operation Key mounting screw	2.4 to 2.8 N·m
Switch mounting screw	1.3 to 1.5 N·m
Connector	1.8 to 2.1 N·m
	1.4 to 1.8 N·m
Cap screw	1.3 to 1.7 N·m

- When loosening a screw with an electrical screwdriver or similar tool while pressing down on the screw head, do not continue turning the screw past the point where the threads disengage. Doing so may strip the end of the threads.

Switch and Operation Key Mounting

- Mount the Switch and Operation Key securely to the applicable tightening torque with M5 screws for the Switch and M4 screws for the Operation Key. Always use spring washers. To ensure safety, use screws that cannot be easily removed or another means to prevent the Switch and Operation Key from easily being removed.
- Do not operate the Switch with anything other than the special OMRON Operation Key. Otherwise, the Switch may be damaged and the safety of the system may not be maintained.

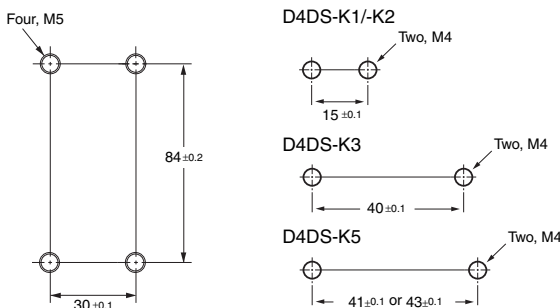

- Ensure that the alignment offset between the Operation Key and the key hole does not exceed ± 1 mm. If the Operation Key is offset or at an angle, accelerated wear or damage to the Switch may result.
- Observe the specified insertion radius for the Operation Key and insert it in a direction perpendicular to the key hole.
- Do not impose excessive force on the Operation Key while the Key is inserted into the Switch or drop the Switch with the Operation Key inserted. Doing either of these may deform the Key or break the Switch.

Head Direction

- Remove the four screws of the head to enable changing the mounting direction of the head. The head can be mounted in four directions. Ensure that no foreign material enters the interior of the Switch. Also, insert the head until the insertion line engraved on the head is hidden by the reference line on the Switch, as shown in the following diagram.
- Do not insert or remove the Operation Key with the Switch head removed. Doing so may make it impossible to insert the Operation Key.

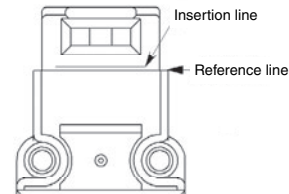

Securing the Door

When the door is closed (with the Operation Key inserted), the Operation Key may exceed the set zone because of, for example, the door's own weight, machine vibration, or the door cushion rubber. Then, when an attempt is made to open the door, it may result in damage or malfunction. Also, it may not be possible to unlock the Switch if there is weight placed on the Operation Key. Do not rely on the Switch to substitute for a door locking device. Secure the door with a stopper so that the Operation Key remains within the set zone.

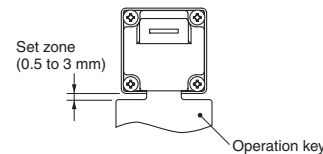

Solenoid

- The solenoid will heat when it carries current. Do not touch it.
- The solenoid has polarity. Confirm terminal polarity before wiring it.

Wiring

Circuit Connection Example for the D4GL-□H□□-A

- Direct opening contacts used as safety-circuit inputs are indicated with the \ominus mark. Terminals 11 and 42, and terminals 21 and 22 have direct opening contacts.
- Connect terminals 21 and 22 and terminals 51 and 52 in series when using as safety-circuit inputs (redundancy circuit for terminals 11 and 12 and terminals 41 and 42 below). Connect the terminals individually when using as auxiliary-circuit inputs (e.g., terminals 21 and 22 for safety-door open/closed monitoring and terminals 51 and 52 for monitoring the lock status).
- In the following connection example, terminals 21 and 22 and terminals 51 and 52 are used as auxiliary-circuit inputs.
- Connect the indicators in parallel to the auxiliary circuits or terminals E1 and E2.
- Although the 3 lines are connected at the time of delivery, rewire them as necessary for the application.
- The following table shows the connection configuration required to make the green indicator light when the door is closed and the orange indicator light when the solenoid turns ON.

Indicator	Terminal number	Lead wire color	Connected terminal number
Green indicator	O1	Green	31
Orange indicator	O3	Orange	E1
Common	O2	Black	E2

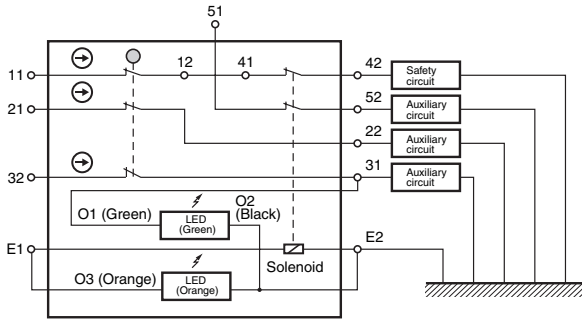

Wiring Precautions

- Do not wire the Switch while power is being supplied. Doing so may result in electric shock.
- Do not let particles, such as small pieces of lead wire, enter the switch body when wiring.
- Applicable lead wire size: AWG24 to AWG22 (0.2 to 0.3 mm²). Use lead wires of an appropriate length. Not doing so may result in excess length causing the cover to rise and not fit properly.
- Do not push crimp terminals into gaps in the case interior. Doing so may cause damage or deformation of the case.
- Use crimp terminals that will not interfere with other components inside the case.

Recommended Crimp Terminals

Manufacturer	Model
J.S.T. Mfg Co.	FN0.5-3 (F Type) No. 5-3 (Straight Type)

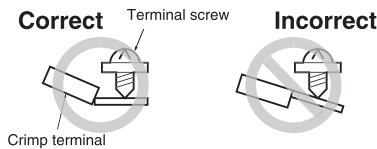
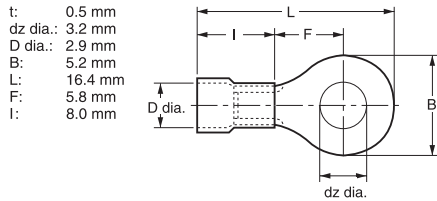

- The terminal block screws and contact numbers correspond as shown in the following diagram. The numbers are provided on the terminal cover. Confirm terminal numbers against the terminal block terminal symbols when wiring.

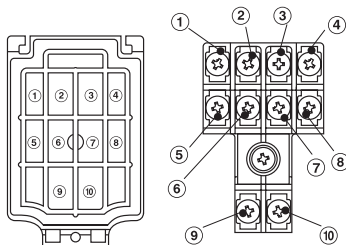

Processing the Conduit Opening

- Connect a recommended connector to the opening of the conduit and tighten the connector to the proper torque. The case may be damaged if excessive tightening torque is applied.
- Make sure that the outer diameter of the cable connected to the connector is correct.
- Attach a conduit cap to the unused conduit opening when wiring and tighten it to a suitable torque. The conduit cap is provided with the Switch.

Recommended Connectors

- Use a connector with a screw section not exceeding 10 mm. Otherwise the screws will protrude into the case interior. The connectors given in the following table have connectors with screw sections not exceeding 10 mm. Use the following connectors to ensure conformance to IP67.

Size	Manufacturer	Model	Applicable cable diameter
G ¹ / ₂	LAPP	ST-PF1/2 5380-1002	6.0 to 12.0 mm
	OHM ELECTRIC CO.	OA-W1609	7.0 to 9.0 mm
OA-W1611		9.0 to 11.0 mm	
Pg13.5	LAPP	S-13.5 5301-5030	6.0 to 12.0 mm
M20	LAPP	ST-M20 × 1.5 5311-1020	7.0 to 13.0 mm

Use LAPP connectors together with Seal Packing (JPK-16, GP-13.5, or GPM20), and tighten to the applicable torque. Seal Packing is sold separately.

- LAPP is a German manufacturer.
- OHM Electric Co. is a Japanese manufacturer.

Read and Understand This Catalog

Please read and understand this catalog before purchasing the products. Please consult your OMRON representative if you have any questions or comments.

Warranty and Limitations of Liability

WARRANTY

OMRON's exclusive warranty is that the products are free from defects in materials and workmanship for a period of one year (or other period if specified) from date of sale by OMRON.

OMRON MAKES NO WARRANTY OR REPRESENTATION, EXPRESS OR IMPLIED, REGARDING NON-INFRINGEMENT, MERCHANTABILITY, OR FITNESS FOR PARTICULAR PURPOSE OF THE PRODUCTS. ANY BUYER OR USER ACKNOWLEDGES THAT THE BUYER OR USER ALONE HAS DETERMINED THAT THE PRODUCTS WILL SUITABLY MEET THE REQUIREMENTS OF THEIR INTENDED USE. OMRON DISCLAIMS ALL OTHER WARRANTIES, EXPRESS OR IMPLIED.

LIMITATIONS OF LIABILITY

OMRON SHALL NOT BE RESPONSIBLE FOR SPECIAL, INDIRECT, OR CONSEQUENTIAL DAMAGES, LOSS OF PROFITS OR COMMERCIAL LOSS IN ANY WAY CONNECTED WITH THE PRODUCTS, WHETHER SUCH CLAIM IS BASED ON CONTRACT, WARRANTY, NEGLIGENCE, OR STRICT LIABILITY.

In no event shall the responsibility of OMRON for any act exceed the individual price of the product on which liability is asserted.

IN NO EVENT SHALL OMRON BE RESPONSIBLE FOR WARRANTY, REPAIR, OR OTHER CLAIMS REGARDING THE PRODUCTS UNLESS OMRON'S ANALYSIS CONFIRMS THAT THE PRODUCTS WERE PROPERLY HANDLED, STORED, INSTALLED, AND MAINTAINED AND NOT SUBJECT TO CONTAMINATION, ABUSE, MISUSE, OR INAPPROPRIATE MODIFICATION OR REPAIR.

Application Considerations

SUITABILITY FOR USE

OMRON shall not be responsible for conformity with any standards, codes, or regulations that apply to the combination of products in the customer's application or use of the products.

At the customer's request, OMRON will provide applicable third party certification documents identifying ratings and limitations of use that apply to the products. This information by itself is not sufficient for a complete determination of the suitability of the products in combination with the end product, machine, system, or other application or use.

The following are some examples of applications for which particular attention must be given. This is not intended to be an exhaustive list of all possible uses of the products, nor is it intended to imply that the uses listed may be suitable for the products:

- Outdoor use, uses involving potential chemical contamination or electrical interference, or conditions or uses not described in this catalog.
- Nuclear energy control systems, combustion systems, railroad systems, aviation systems, medical equipment, amusement machines, vehicles, safety equipment, and installations subject to separate industry or government regulations.
- Systems, machines, and equipment that could present a risk to life or property.

Please know and observe all prohibitions of use applicable to the products.

NEVER USE THE PRODUCTS FOR AN APPLICATION INVOLVING SERIOUS RISK TO LIFE OR PROPERTY WITHOUT ENSURING THAT THE SYSTEM AS A WHOLE HAS BEEN DESIGNED TO ADDRESS THE RISKS, AND THAT THE OMRON PRODUCTS ARE PROPERLY RATED AND INSTALLED FOR THE INTENDED USE WITHIN THE OVERALL EQUIPMENT OR SYSTEM.

PROGRAMMABLE PRODUCTS

OMRON shall not be responsible for the user's programming of a programmable product, or any consequence thereof.

Disclaimers

CHANGE IN SPECIFICATIONS

Product specifications and accessories may be changed at any time based on improvements and other reasons.

It is our practice to change model numbers when published ratings or features are changed, or when significant construction changes are made. However, some specifications of the products may be changed without any notice. When in doubt, special model numbers may be assigned to fix or establish key specifications for your application on your request. Please consult with your OMRON representative at any time to confirm actual specifications of purchased products.

DIMENSIONS AND WEIGHTS

Dimensions and weights are nominal and are not to be used for manufacturing purposes, even when tolerances are shown.

PERFORMANCE DATA

Performance data given in this catalog is provided as a guide for the user in determining suitability and does not constitute a warranty. It may represent the result of OMRON's test conditions, and the users must correlate it to actual application requirements. Actual performance is subject to the OMRON Warranty and Limitations of Liability.

ERRORS AND OMISSIONS

The information in this document has been carefully checked and is believed to be accurate; however, no responsibility is assumed for clerical, typographical, or proofreading errors, or omissions.

2012.1

In the interest of product improvement, specifications are subject to change without notice.

OMRON Corporation
Industrial Automation Company

<http://www.ia.omron.com/>

(c)Copyright OMRON Corporation 2012 All Right Reserved.

Mouser Electronics

Authorized Distributor

Click to View Pricing, Inventory, Delivery & Lifecycle Information:

Omron:

[D4GLSK10LK](#) [D4GL-SK10-LK](#) [D4GL-4EFG-A4-NPT](#) [D4GL2CFGA](#) [D4GL-4EFA-A-NPT](#) [D4GL-4EFG-A-NPT](#)



Компания «ЭлектроПласт» предлагает заключение долгосрочных отношений при поставках импортных электронных компонентов на взаимовыгодных условиях!

Наши преимущества:

- Оперативные поставки широкого спектра электронных компонентов отечественного и импортного производства напрямую от производителей и с крупнейших мировых складов;
- Поставка более 17-ти миллионов наименований электронных компонентов;
- Поставка сложных, дефицитных, либо снятых с производства позиций;
- Оперативные сроки поставки под заказ (от 5 рабочих дней);
- Экспресс доставка в любую точку России;
- Техническая поддержка проекта, помощь в подборе аналогов, поставка прототипов;
- Система менеджмента качества сертифицирована по Международному стандарту ISO 9001;
- Лицензия ФСБ на осуществление работ с использованием сведений, составляющих государственную тайну;
- Поставка специализированных компонентов (Xilinx, Altera, Analog Devices, Intersil, Interpoint, Microsemi, Aeroflex, Peregrine, Syfer, Eurofarad, Texas Instrument, Miteq, Cobham, E2V, MA-COM, Hittite, Mini-Circuits, General Dynamics и др.);

Помимо этого, одним из направлений компании «ЭлектроПласт» является направление «Источники питания». Мы предлагаем Вам помощь Конструкторского отдела:

- Подбор оптимального решения, техническое обоснование при выборе компонента;
- Подбор аналогов;
- Консультации по применению компонента;
- Поставка образцов и прототипов;
- Техническая поддержка проекта;
- Защита от снятия компонента с производства.



Как с нами связаться

Телефон: 8 (812) 309 58 32 (многоканальный)

Факс: 8 (812) 320-02-42

Электронная почта: org@eplast1.ru

Адрес: 198099, г. Санкт-Петербург, ул. Калинина, дом 2, корпус 4, литера А.