

Analog Light Grid in Robust Aluminum Housing

F3EM2

The F3EM2 light grids provide reliable area monitoring in a robust housing. The analog output provides simple area measurement such as height detection.

- Robust aluminium housing
- Analog output for simple height detection
- Brackets included with Light Grids
- Measurement ranges from 150 mm up to 2100 mm.

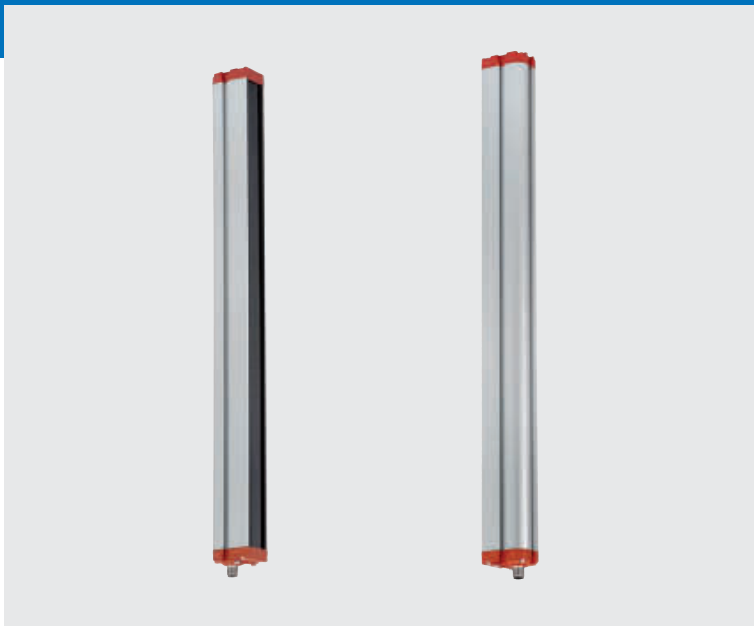

Ordering Information

Measurement Range (mm)	Pitch	Sensing Distance	Beams	Connection	Model
150	5 mm	3	30	M12-5pin	F3EM2-005-150-AV
	18 mm	15	8		F3EM2-018-150-AV
300	5 mm	3	60		F3EM2-005-300-AV
	18 mm	15	16		F3EM2-018-300-AV
450	5 mm	3	90		F3EM2-005-450-AV
	18 mm	15	24		F3EM2-018-450-AV
600	5 mm	3	120		F3EM2-005-600-AV
	18 mm	15	32		F3EM2-018-600-AV
900	5 mm	3	180		F3EM2-005-900-AV
	18 mm	15	48		F3EM2-018-900-AV
1200	5 mm	3	240		F3EM2-005-1200-AV
	18 mm	15	64		F3EM2-018-1200-AV
1500	5 mm	3	300		F3EM2-005-1500-AV
	18 mm	15	80		F3EM2-018-1500-AV
1800	5 mm	3	360	F3EM2-005-1800-AV	
	18 mm	15	96	F3EM2-018-1800-AV	
2100	18 mm	15	112	F3EM2-018-2100-AV	

Rating/Specifications

	F3EM2-005_	F3EM2-018_
Sensing distance	0 to 3 m	0 to 15 m
Vertical measurement range	0 to: 150, 300, 450, 600, 900, 1200, 1500, 1800 mm	0 to: 150, 300, 450, 600, 900, 1200, 1500, 1800, 2100 mm
Minimum detectable object size	10 mm	30 mm
Beam axis pitch	5 mm	18 mm
Analog output	0-10 VDC (12 bits), max. load current 15 mA	
External input	Strobe signal (for alignment procedure)	
Response time	4 ms + 80 μs x number of beams	
Power-on delay	1 s max	
Light source (wavelength)	Infrared LED (880 nm)	
Power supply voltage	24 VDC ±20%	
Current consumption	150 mA max	
Operating temperature	-10 to 55°C	
Storage temperature	-25 to 70°C	
Protective circuits	Reverse polarity protection, output short-circuit protection	
Degree of protection	IEC 60529 IP65	
Material	Case	Aluminium
	Cover	Polycarbonate

Connector cables

	Type	Features	Material		Model	
			Nut	cable	straight	angled
M12	General purpose	5 wires	CuZn	PVC 2 m	XS2F-M12PVC5S2M	XS2F-M12PVC5A2M
				PUR 2 m	XS2F-M12PUR5S2M	XS2F-M12PUR5A2M
				PVC 5 m	XS2F-M12PVC5S5M	XS2F-M12PVC5A5M
				PUR 5 m	XS2F-M12PUR5S5M	XS2F-M12PUR5A5M

Output circuits

Analog models (F3EM2-[...]-AV)

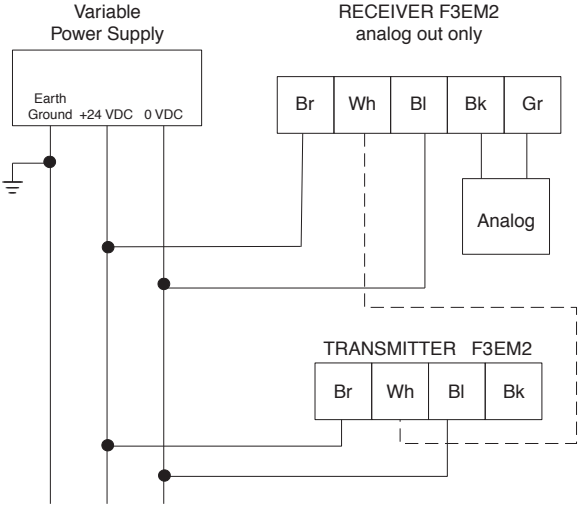

Connector PIN assignment - Receiver

Type	Internal wiring	Pin	Color	Signal name
M12 n5 pole		1	Brown	+Vs
		2	White	Wire sync
		3	Blue	0V
		4	Black	Analog +
		5	Gray	Analog reference

Connector PIN assignment - Transmitter

Type	Internal wiring	Pin	Color	Signal name
M12 n4 pole		1	Brown	+Vs
		2	White	Wire sync
		3	Blue	0V
		4	Black	Not used

For synchronization by wire please connect white wires of transmitter and receiver.

Dimensions

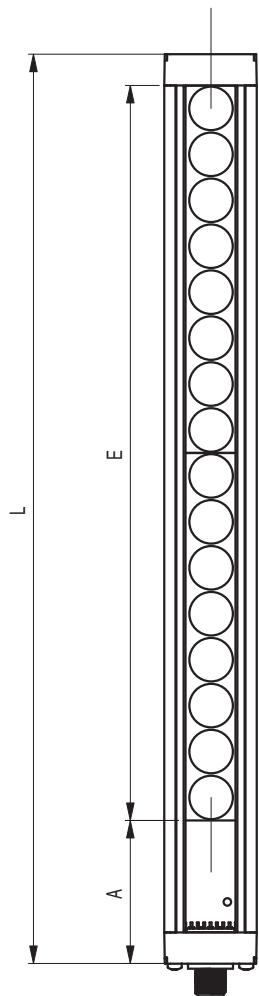

- L: Total length
- E: Detection zone
- A: Dead zone without detection capability

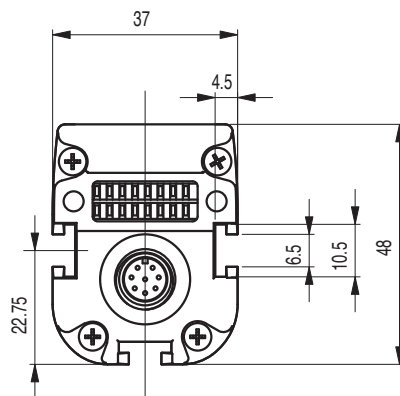

All dimensions shown are in mm

Model	Detection Zone E (mm)	Total length L (mm)
F3EM2-005-150-AV	159	218
F3EM2-018-150-AV	147	217
F3EM2-005-300-AV	318	277
F3EM2-018-300-AV	294	364
F3EM2-005-450-AV	477	536
F3EM2-018-450-AV	441	511
F3EM2-005-600-AV	636	695
F3EM2-018-600-AV	588	658
F3EM2-005-900-AV	954	1013
F3EM2-018-900-AV	882	952
F3EM2-005-1200-AV	1272	1331
F3EM2-018-1200-AV	1176	1246
F3EM2-005-1500-AV	1590	1649
F3EM2-018-1500-AV	1470	1540
F3EM2-005-1800-AV	1908	1967
F3EM2-018-1800-AV	1764	1834
F3EM2-018-2100-AV	2058	2128

Operation

The F3EM2 measuring light grid features optical synchronization. This function is provided by the upper beam located on the opposite side of the connector (see illustration below). During operation this beam must always be kept free (unblocked). Otherwise it will result in a loss of synchronism between the transmitter and receiver. For applications where all beams are interrupted, synchronization by wiring can be activated via dip switch settings. Please refer to chapter 4 or 5 in the operating manual.

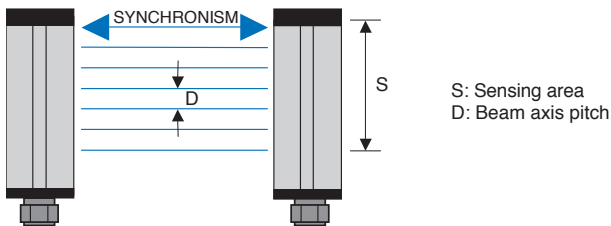

Indicator LEDs

For functions of indicator LEDs please refer to the tables below:

Status of Receiver is displayed by 5 LEDs:

Disposition of indicator	Name of indicator	Color
	POWER	Green
	RUN	Yellow
	FREE	Green
	BREAK	Red
	STATUS	Yellow

Status of Transmitter is displayed by 5 LEDs:

Disposition of indicator	Name of indicator	Color
	POWER	Green
	STATUS 1	Yellow
	RANGE	Green
	Not used	
	STATUS 2	Yellow

Selector switches (dip switches)

Various output modes, synchronization by wire, can be changed by selector switches. To access selector switches unscrew the end cap of the receiver unit:

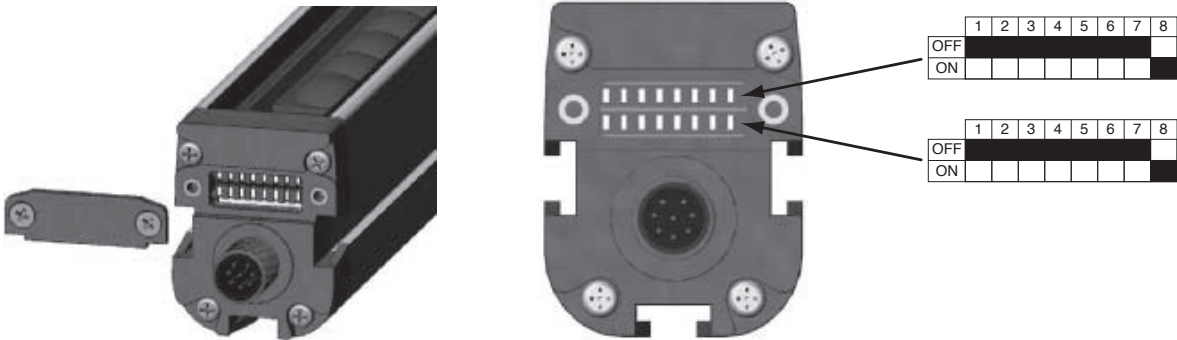

Note: There are two lines of dip switches in each transmitter and receiver. The settings must be done for both lines. Change the setting of the dip-switch and close the cap again. The light grid can now be reconnected to the power supply.

Mounting

Mounting accessories

The F3EM2 system is mechanically installed by using the T-slots on the two sides or the back-side of the housing.

Use the movable bolts, washers, spacers and nuts to attach the mounting brackets as shown in the picture

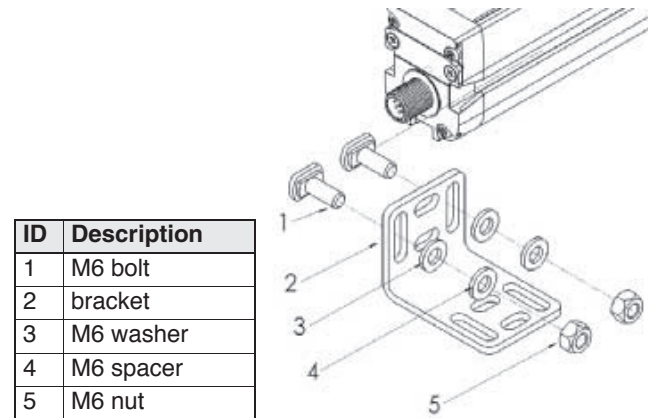

Note: Shipments contain a different quantity of brackets, depending on the length of the light grid. Longer light grids contain a higher number of brackets, following the rule of one bracket every 400 mm.

Additional mounting rigidity

It is recommended that the distance between the mounting brackets is 400 mm or less for optimum performance of the F3EM2 system.

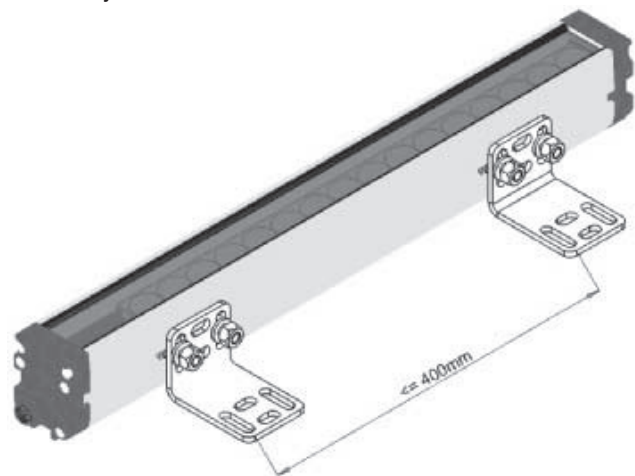

Mechanical Mounting

Please mount the light grids in proper alignment as shown in the pictures below by using the brackets provided with the light grids.

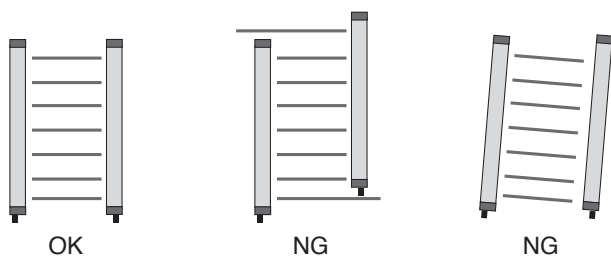

If several light grids are installed close to each other, interference of the light grids must be avoided. In this case the assembly should be carried out as follows:

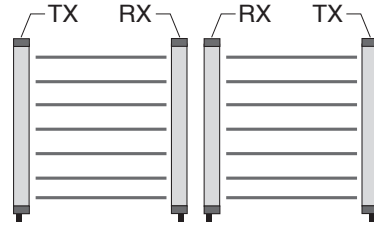

Precautions

△ WARNING

The F3EM2 multi-beam photoelectric sensor with beam evaluation function is not a safety component for ensuring the safety of people which is defined in EC directive (2006/42/EC) or by any other regulations or standards.

Power Supply Voltage and Output Load Power Supply Voltage

Do not connect an AC power supply to the Sensor. If AC power is supplied to the Sensor, it may be damaged, explode or burn. Make sure that the power supply to the Sensor is within the rated voltage range. If a voltage exceeding the rated voltage range is supplied to the Sensor, it may explode or burn.

Operating Environment

Do not use the sensor in locations with explosive or flammable gas. Make sure that the product is operated in accordance with IP65 standards.

Do not subject the sensor to excessive shock when mounting.

When you use the sensor in the vicinity of an inverter motor, be sure to connect the protective earth ground wire of the motor to earth. Failure to ground the motor may result in malfunction of the sensor.

Mounting the Sensor

Do not strike the sensor with a hammer or any other tool during the installation of the Sensor.

Cleaning

Never use paint thinners or other organic solvents to clean the surface of the product

M12 Connector

Always turn OFF the power supply to the sensor before connecting or disconnecting the metal connector. Hold the connector cover to connect or disconnect it.

Secure the connector cover by hand. Do not use pliers; otherwise the connector may be damaged.

If the connector is not connected securely, it may be disconnected by vibration or the proper degree of protection of the sensor may not be maintained.

OMRON AUTOMATION AND SAFETY • THE AMERICAS HEADQUARTERS • Schaumburg, IL USA • 847.843.7900 • 800.556.6766 • www.omron247.com

OMRON CANADA, INC. • HEAD OFFICE

Toronto, ON, Canada • 416.286.6465 • 866.986.6766 • www.omron247.com

OMRON ELECTRONICS DE MEXICO • HEAD OFFICE

México DF • 52.55.59.01.43.00 • 001.800.556.6766 • mela@omron.com

OMRON ELECTRONICS DE MEXICO • SALES OFFICE

Apodaca, N.L. • 52.81.11.56.99.20 • 001.800.556.6766 • mela@omron.com

OMRON ELETRÔNICA DO BRASIL LTDA • HEAD OFFICE

São Paulo, SP, Brasil • 55.11.2101.6300 • www.omron.com.br

OMRON ARGENTINA • SALES OFFICE

Cono Sur • 54.11.4783.5300

OMRON CHILE • SALES OFFICE

Santiago • 56.9.9917.3920

OTHER OMRON LATIN AMERICA SALES

54.11.4783.5300

OMRON EUROPE B.V. • Wegalaan 67-69, NL-2132 JD, Hoofddorp, The Netherlands. • Tel: +31 (0) 23 568 13 00 • Fax: +31 (0) 23 568 13 88 • www.industrial.omron.eu



Компания «ЭлектроПласт» предлагает заключение долгосрочных отношений при поставках импортных электронных компонентов на взаимовыгодных условиях!

Наши преимущества:

- Оперативные поставки широкого спектра электронных компонентов отечественного и импортного производства напрямую от производителей и с крупнейших мировых складов;
- Поставка более 17-ти миллионов наименований электронных компонентов;
- Поставка сложных, дефицитных, либо снятых с производства позиций;
- Оперативные сроки поставки под заказ (от 5 рабочих дней);
- Экспресс доставка в любую точку России;
- Техническая поддержка проекта, помощь в подборе аналогов, поставка прототипов;
- Система менеджмента качества сертифицирована по Международному стандарту ISO 9001;
- Лицензия ФСБ на осуществление работ с использованием сведений, составляющих государственную тайну;
- Поставка специализированных компонентов (Xilinx, Altera, Analog Devices, Intersil, Interpoint, Microsemi, Aeroflex, Peregrine, Syfer, Eurofarad, Texas Instrument, Miteq, Cobham, E2V, MA-COM, Hittite, Mini-Circuits, General Dynamics и др.);

Помимо этого, одним из направлений компании «ЭлектроПласт» является направление «Источники питания». Мы предлагаем Вам помощь Конструкторского отдела:

- Подбор оптимального решения, техническое обоснование при выборе компонента;
- Подбор аналогов;
- Консультации по применению компонента;
- Поставка образцов и прототипов;
- Техническая поддержка проекта;
- Защита от снятия компонента с производства.



Как с нами связаться

Телефон: 8 (812) 309 58 32 (многоканальный)

Факс: 8 (812) 320-02-42

Электронная почта: org@eplast1.ru

Адрес: 198099, г. Санкт-Петербург, ул. Калинина, дом 2, корпус 4, литера А.