

3M™ Hot Melt Fiber Optic Connectors, Kits and Accessories

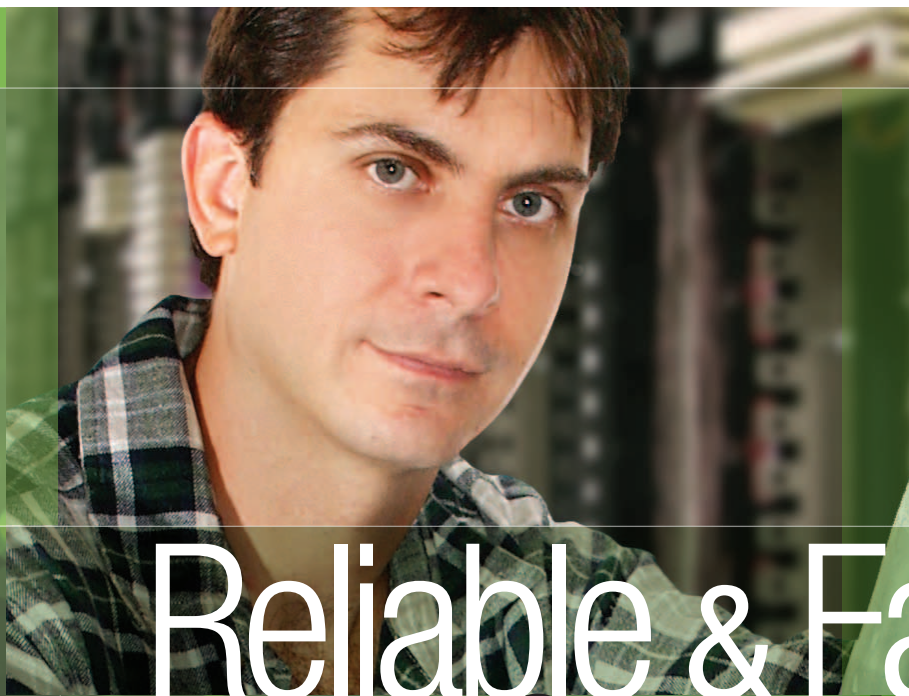

Reliable & Fast
Connections



3M™ Hot Melt Connectors are among the most popular with contractors because of their reliability and ease of use. They come pre-loaded with an adhesive with a very long shelf life, and the termination procedure provides the ability to reheat and reposition the fiber in the termination process. This easy-to-install field mount connector provides reliable performance in indoor and outdoor applications and has no internal splice.

All 3M hot melt connectors can be terminated using the same 3M™ Hot Melt Termination Kit 6366/6362. 3M™ LC Connectors also require the 3M™ LC Hot Melt Expansion Kit 6650-LC which includes a weighted polishing jig to provide a PC centered apex end face.

Applications

The 3M Hot Melt Connectors are specifically designed for installation in singlemode and multimode fiber data transport systems, including the latest OM3 and OM4 laser optimized fibers for multi-gigabit transmission speed. These include building and campus Local Area Network (LAN) backbones, factory and industrial control systems, traffic control systems and enterprise networks.

Hot Melt Connectors are fast and reliable for termination of multifiber distribution and breakout cables. They can be used for termination and restoration of patch cords.

The applications for the hot melt connector are based on TIA-568, ISO 11801, and EN 50173 standards for performance over environmental extremes.

3M™ Hot Melt Connectors

- Singlemode and multimode local area networks and campus wiring
- Singlemode data centers and CATV headend
- Environmental performance of all hot melt connectors exceed EIA/TIA 568-C.3
- SC and LC connectors meet performance standards of ISO 11801 and EN 50173
- Singlemode reflection performance of -55dB at temperature extremes
- Available in LC, ST, SC, FC singlemode and multimode connectors
- Provides reliable performance in a wide range of indoor and outdoor applications



3M™ Multimode Duplex LC Connector 6600



3M™ Multimode ST Connector 6100



3M™ Singlemode SC Connector 8300



3M™ Singlemode FC Connector 8200

3M™ Hot Melt Connectors – LC, ST, SC, FC

Features	Benefits
Meets TIA/EIA 568-C.3 standard for indoor and outdoor applications	Long term reliability
Ease of use on backbone and horizontal cable	Quick termination in <2 minutes; high yield
Allows custom length cable assemblies to be built on site	Enhances cable management in telecom room or central office Minimizes cable slack
Adhesive fiber retention	Not dependent on mechanical retention alone
3M field polishing process produces <55dB reflection, singlemode	Reliable in high speed transmission
Pre-loaded adhesive	No epoxy mixing or mess; no pot life
Re-heatable adhesive	Allows fiber repositioning
Blue dot of adhesive after fiber insertion	Easy to see when polishing is complete

Specifications	Multimode	Singlemode
Product Number	6100 ST Series 6200 FC Series 6300 SC Series 6600 LC Series	8100 ST Series 8200 FC Series 8300 SC Series 8600 LC Series
Testing Specification	TIA/EIA 568-C.3	TIA/EIA 568-C.3
Operating Temperature	-10°C to +60°C (+14°F to +140°F)	-10°C to +60°C (+14°F to +140°F)
Attenuation*	<0.2dB typical	<0.2dB typical
Reflection*	-25dB typical	-55dB typical
Mating Durability 300 Matings	<0.2dB change	<0.2dB change
Storage Temperature	-40°C to +85°C (-40°F to +185°F)	-40°C to +85°C (-40°F to +185°F)
Materials and Identification		
Ferrule	Zirconia ceramic	Zirconia ceramic
Housing Body	Nickel plated zinc (ST) Engineered resin (LC, SC, FC)	Nickel plated zinc (ST) Engineered resin (LC, SC, FC)
Boot	Thermoplastic elastomer	Thermoplastic elastomer
Flame Retardancy	UL-94 V-0	UL-94 V-0
Adhesive	Pre-loaded blue hot melt	Pre-loaded blue hot melt

*Multimode connectors tested at 850nm and 1300nm.

*Singlemode connectors tested at 1310nm and 1550nm.

Long-term Reliability

3M™ ST Hot Melt Connector

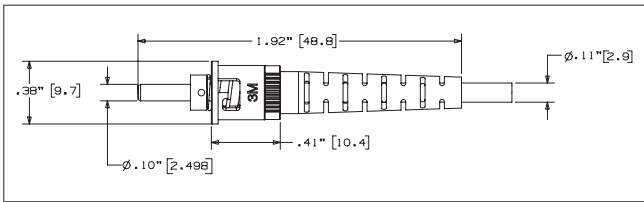

3M™ SC Hot Melt Connector

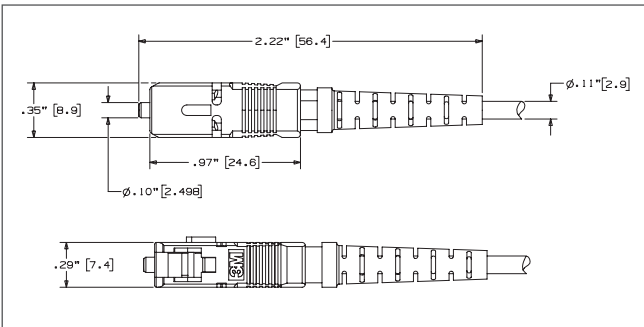

3M™ FC Hot Melt Connector

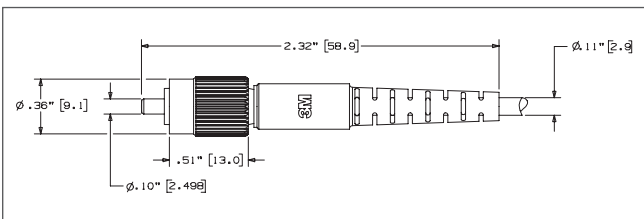

Note: ST hotmelt connectors are packaged for termination of 900 micron buffer, 2.4 mm and 3.0 mm jacketed cable.

SC and FC hot melt connectors are packaged for termination of 900 micron buffer and 3.0 mm jacketed cable.

For SC and FC termination of 2.4 mm jacketed cable, order the additional SC-FC Crimp Ring.

3M™ LC Hot Melt Connector

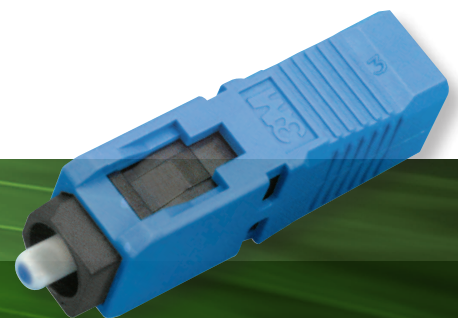
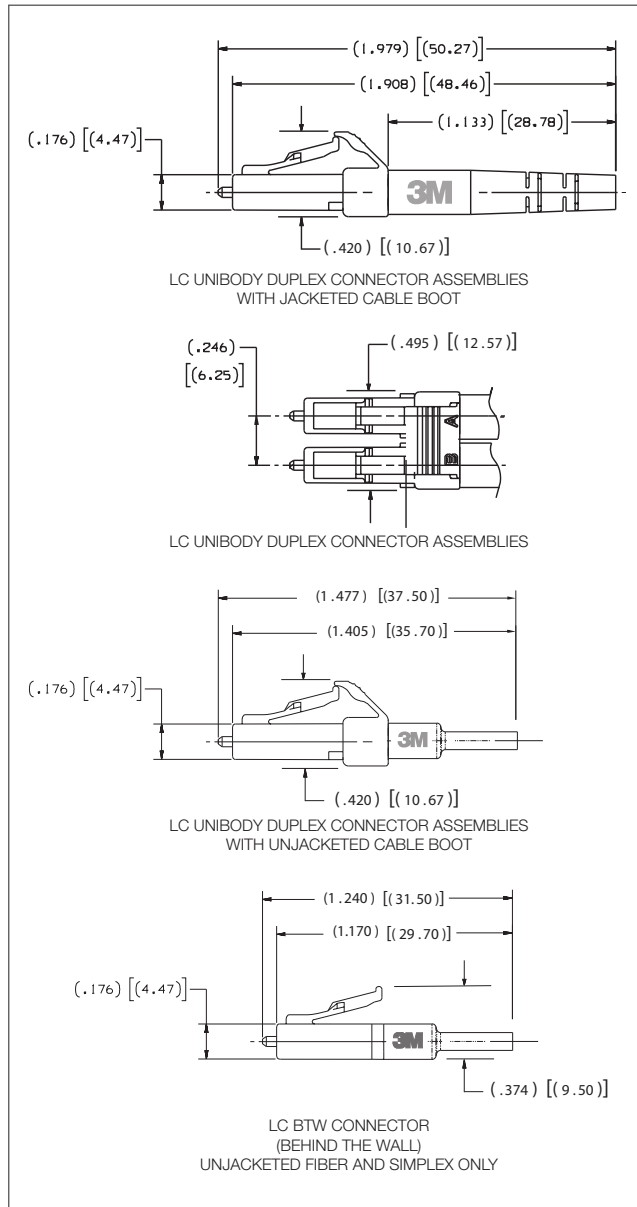

Ordering Information

Product Number	Description	Minimum Order	Packaging
3M™ LC Connectors			
6600-S	MM hot melt simplex 900 BTW, white boot	60	1/bag, 60/carton
6602-S	MM hot melt simplex 1.6-2.0 cable, white boot	60	1/bag, 60/carton
6603-S	MM hot melt simplex 2.4-3.0 cable, white boot	60	1/bag, 60/carton
6601-D	MM hot melt duplex 900 buffer, white/beige boots	60	1/bag, 60/carton
6602-D	MM hot melt duplex 1.6-2.0 cable, white/beige boots	60	1/bag, 60/carton
6603-D	MM hot melt duplex 2.4-3.0 cable, white/beige boots	60	1/bag, 60/carton
6604-D	MM hot melt duplex 900 buffer, red/black boots	60	1/bag, 60/carton
6605-D	MM hot melt duplex 1.6-2.0 cable, red/black boots	60	1/bag, 60/carton
6606-D	MM hot melt duplex 2.4-3.0 cable, red/black boots	60	1/bag, 60/carton
8600-S	SM hot melt simplex 900 BTW, white boot	60	1/bag, 60/carton
8602-S	SM hot melt simplex 1.6-2.0 cable, white boot	60	1/bag, 60/carton
8603-S	SM hot melt simplex 2.4-3.0 cable, white boot	60	1/bag, 60/carton
8601-D	SM hot melt duplex 900 buffer, white/beige boots	60	1/bag, 60/carton
8602-D	SM hot melt duplex 1.6-2.0 cable, white/beige boots	60	1/bag, 60/carton
8603-D	SM hot melt duplex 2.4-3.0 cable, white/beige boots	60	1/bag, 60/carton
3M™ ST Connectors			
6100-W	MM hot melt connector, white boot	60	1/bag, 60/carton
6100-B	MM hot melt connector, black boot	60	1/bag, 60/carton
6100-R	MM hot melt connector, red boot	60	1/bag, 60/carton
6100-W1K	MM hot melt connector, white boot	1,000	1/bag, 1,000/carton
6100-B1K	MM hot melt connector, black boot	1,000	1/bag, 1,000/carton
6100-R1K	MM hot melt connector, red boot	1,000	1/bag, 1,000/carton
8100-YS	SM hot melt connector, yellow boot	60	1/bag, 60/carton
8100-Y1K	SM hot melt connector, yellow boot	1,000	1/bag, 1,000/carton
3M™ FC Connectors			
6200	MM hot melt connector, white boot	60	1/bag, 60/carton
8200-W	SM hot melt connector, white boot	60	1/bag, 60/carton
3M™ SC Connectors			
6300-W	MM hot melt connector, white boot	60	1/bag, 60/carton
6300-W1K	MM hot melt connector, white boot	1,000	1/bag, 1,000/carton
6300-B1K	MM hot melt connector, black boot	1,000	1/bag, 1,000/carton
6300-R1K	MM hot melt connector, red boot	1,000	1/bag, 1,000/carton
8300	SM hot melt connector, white boot	60	1/bag, 60/carton
8300-W1K-S	SM hot melt connector, white boot	1,000	1/bag, 1,000/carton
Crimp Ring			
SC-FC	Crimp Ring 2.4 mm red 60-bulk	1 package	60/package

3M™ Hot Melt Termination Kits

The 3M™ Hot Melt Termination Kits 6366 (120V oven) and 6362 (230V oven) contain all materials necessary to terminate 3M SC, ST, and FC hot melt connectors, both singlemode and multimode. An LC expansion kit makes it easy to incorporate the LC hot melt process into one kit.



3M™ LC Hot Melt Expansion Kit 6650-LC



3M™ Hot Melt Termination Kits 6366 and 6362

The 3M™ LC Hot Melt Expansion Kit 6650-LC is used in addition to the 6366/6362 hot melt termination kits. The LC expansion kit contains the tools needed to terminate 3M™ LC Hot Melt Connectors that are not included in the 6366/6362 termination kits.



3M™ Hot Melt Polishing Machine 6851-E

The 3M™ Hot Melt Polishing Machine 6851-E features a fast, simple step polishing technology, used for multimode 3M Hot Melt connectors. This machine is used to polish two hot melt connectors at a time—SC, ST or FC—saving time and labor over hand polishing.

Features	Benefits
Premium microscope with oblique and coaxial lighting	Better view of fiber end face inspection
Roll-up tool pouch	Tools are organized and accessible
Universal hot melt holders	Fewer parts to carry, holds cable more securely
Instruction CD	Organized into video segments for quick reference

Ordering Information - Hot Melt Termination Kits

Product Number	Description	Minimum Order	Packaging
6366	Hot melt termination kit for ST, FC, SC hot melt connectors, 120V	1	1 each
6362	Hot melt termination kit for ST, FC, SC hot melt connectors, 230V	1	1 each
6650-LC	LC Hot Melt expansion kit (required with 6366/6362)	1	1 each

3M™ Hot Melt Termination Kit 6366/6362 Contents

Product Number	Description	Contents Quantity	Replacement Minimum Order	Packaging
6312	120V oven (6366 Kit)	1	1	1
6323	230V oven (6362 Kit)	1	1	1
6365-HH	Universal holder	4	4	4/pkg
6365-PP	Round polishing pad	2	1	1
6192-9RN	9 µm lapping film (slate gray)	10	50	50
6192-A-254X-2D5	2 µm lapping film (pale green)	50	500	500/pkg
863X-0.02S	Final lapping film (frosted)	20	50	50/pkg
8892	Polishing jig	2	1	1
6365-KS	Kevlar snips	1	1	1
6362-TH	Stripping tool	1	1	1
6365-CT	Crimp tool	1	1	1
6365-FS	Fiber scribe	1	1	1
6365-VS	View scope (200X)	1	1	1
6366-CW	Lint-free wipes with dispenser	100	100	100/pkg
	Pronto adhesive	1	-	-
	120V power cord (6366 Kit)	1	-	-
	230V UK power cord (6362 Kit)	1	-	-
	230V EU power cord (6362 Kit)	1	-	-
	Alcohol bottle (empty)	1	-	-
	Water bottle (empty)	1	-	-
	Fiber scrap can, plastic	1	-	-
	Roll up pouch	1	-	-
	Fiber marking pen	1	-	-
	Black Plastic Box	1	-	-
	Laminated Stripping Template	1	-	-
78-8140-4734-2	Training CD ROM	1	-	-
78-8073-7873-8-C	Instructions (paper)	1	-	-

*Kit consumables provides up to 100 total polished ends multimode or singlemode, combined.

3M™ LC Hot Melt Expansion Kit 6650 Contents

Product Number	Description	Contents Quantity	Replacement Minimum Order	Packaging
6650-LH	Hot melt connector holder	4	4	4/pkg
6650-JW	Polishing guide w/ weight (includes 2 jigs)	1	1	1
6650-LS	Replacement polishing jigs	0	2	2/pkg
6650-LT	Crimp tool	1	1	1
6650-VS	Adapter for 6365-VS view scope	1	1	1
6650-HS	Heat shrink fixture	1	1	1
6650-HC	Holder cleaning pin	3	3	3/pkg
6650-LP	Polishing pad 4.5 x 5.5	2	2	2/pkg
	Instruction manual	1	-	-
	Lapping film, start-up kit*	1	-	-
	Laminated stripping template	1	-	-

*Up to 100 total polished multimode ends, or up to 50 singlemode ends with 50 multimode ends

Ordering Information - 3M™ Hot Melt Polishing Machine and other Kit Accessories

Product Number	Description	Minimum Order	Packaging
6851-E	Hot melt polishing machine	1	1 kit
6392	SC holder for 6850-A polishing machine (legacy)	1	1 kit
6692	LC Holder for 6850-A polishing machine (legacy)	1	1 Kit
6192-B	Lapping film for 6850-A and 6851-E polishing machine	2 pkg	500 shts/pkg
6365-CC	Hot melt consumable kit for ST, SC, FC Lapping film, 2 µm (254X) Lapping film, 0.05 µm (263X) Lint free cloths 8892 universal polishing jig	1	1 each 200 sheets 50 sheets 200 sheets 1 each
6650-LS	LC lapping film singlemode consumable kit (polishes 400 connectors) Lapping film, 9 µm (461X) Lapping film, 2 µm (254X) Lapping film, 0.5 µm (661X) Lapping film, final polish (863XW)	1	1 each 20 sheets 100 sheets 40 sheets 80 sheets
6650-LM	LC lapping film multimode consumable kit (polishes 400 connectors) Lapping film, 9 µm (461X) Lapping film, 2 µm (254X)	1	1 each 20 sheets 100 sheets
6190	ST Connector Holder for Hot Melt Oven	1	6 pack
SP-00504	SC Connector Holder for Hot Melt Oven	1	4 pack
SP-00505	FC Connector Holder for Hot Melt Oven	1	4 pack
6191	Hot Melt Cooling Stand	1	1 each

A complete line of ST, FC, SC and LC coupling adapters are available. For more information, please contact your 3M sales representative at 800-426-8688.

3M is a trademark of 3M Company.

Important Notice

All statements, technical information, and recommendations related to 3M's products are based on information believed to be reliable, but the accuracy or completeness is not guaranteed. Before using this product, you must evaluate it and determine if it is suitable for your intended application. You assume all risks and liability associated with such use. Any statements related to the product which are not contained in 3M's current publications, or any contrary statements contained on your purchase order shall have no force or effect unless expressly agreed upon, in writing, by an authorized officer of 3M.

Warranty; Limited Remedy; Limited Liability.

This product will be free from defects in material and manufacture for a period of 12 months from the time of purchase. **3M MAKES NO OTHER WARRANTIES INCLUDING, BUT NOT LIMITED TO, ANY IMPLIED WARRANTY OF MERCHANTABILITY OR FITNESS FOR A PARTICULAR PURPOSE.** If this product is defective within the warranty period stated above, your exclusive remedy shall be, at 3M's option, to replace or repair the 3M product or refund the purchase price of the 3M product. **Except where prohibited by law, 3M will not be liable for any loss or damage arising from this 3M product, whether indirect, special, incidental or consequential regardless of the legal theory asserted.**



Communication Markets Division

6801 River Place Blvd.
Austin, TX 78726-9000
800/426 8688
Fax 800/626 0329
www.3M.com/telecom

Please recycle. Printed in USA.
© 3M 2011. All rights reserved.
80-6113-2816-4



Компания «ЭлектроПласт» предлагает заключение долгосрочных отношений при поставках импортных электронных компонентов на взаимовыгодных условиях!

Наши преимущества:

- Оперативные поставки широкого спектра электронных компонентов отечественного и импортного производства напрямую от производителей и с крупнейших мировых складов;
- Поставка более 17-ти миллионов наименований электронных компонентов;
- Поставка сложных, дефицитных, либо снятых с производства позиций;
- Оперативные сроки поставки под заказ (от 5 рабочих дней);
- Экспресс доставка в любую точку России;
- Техническая поддержка проекта, помощь в подборе аналогов, поставка прототипов;
- Система менеджмента качества сертифицирована по Международному стандарту ISO 9001;
- Лицензия ФСБ на осуществление работ с использованием сведений, составляющих государственную тайну;
- Поставка специализированных компонентов (Xilinx, Altera, Analog Devices, Intersil, Interpoint, Microsemi, Aeroflex, Peregrine, Syfer, Eurofarad, Texas Instrument, Miteq, Cobham, E2V, MA-COM, Hittite, Mini-Circuits, General Dynamics и др.);

Помимо этого, одним из направлений компании «ЭлектроПласт» является направление «Источники питания». Мы предлагаем Вам помощь Конструкторского отдела:

- Подбор оптимального решения, техническое обоснование при выборе компонента;
- Подбор аналогов;
- Консультации по применению компонента;
- Поставка образцов и прототипов;
- Техническая поддержка проекта;
- Защита от снятия компонента с производства.



Как с нами связаться

Телефон: 8 (812) 309 58 32 (многоканальный)

Факс: 8 (812) 320-02-42

Электронная почта: org@eplast1.ru

Адрес: 198099, г. Санкт-Петербург, ул. Калинина, дом 2, корпус 4, литера А.