



Test Pro

Test and measurement cable assemblies

RADIALL 
The next conneXion

COMPANY PROFILE



Technical information and sales contacts are available at: www.radiall.com

Simply Your Best Connection

Radiall is a global leader in the design, development and manufacturing of leading edge interconnect solutions. Dedicated to understanding its customers' needs since 1952, Radiall has earned the reputation of being "the best of the best" in engineering ingenuity by providing a constant flow of creative system solutions serving the telecommunications, aerospace, defense, instrumentation, automotive, industrial, medical and broadcast markets.

The Best End-to-End Interconnect Solutions

We offer an extensive range of solutions that support the most demanding signal transmission applications. 4G wireless infrastructure, active array radars, IED detection, electrical wiring in aircrafts, soldier tactical radios, in-vehicle communications networks, and magnetic resonance imaging systems are just a few of the complex applications that we support.

- RF coaxial connectors
- Fiber optic connectors and transceivers
- Coaxial and fiber optic cable assemblies and harnesses
- High frequency microwave components
- Coaxial switches, including the smallest and most reliable SPDT relay
- Multipin rectangular connectors
- Rack and panel connectors
- Antennas for tactical networks, aerospace and instrumentation

Best Value-added Services

- **Collaboration:** We work closely with your engineers to understand your business, your technical needs, and your budgetary issues
- **Wide Product Range:** We manage our product lines throughout the entire lifecycle, in order to offer you a wide selection of standard products at an affordable cost
- **Custom Products:** We can custom tailor products to specific equipment and application needs;
- **Global Presence:** We're everywhere you need us, with worldwide sales, engineering support, R&D in North America, Europe, and Asia, and manufacturing facilities strategically located in the United States, Mexico, France, India, and China
- **Responsive Support and Service:** From the design stage, planning to post-installation support, we're with you at every step, whether you need sales support or engineering expertise
- **On-time Delivery:** We support your logistical needs so you get the products when and where you need them
- **Warranty:** We proudly stand behind our products

Certifications and Environmental



Radiall is ISO 9001: 2008 certified and dedicated to continuous improvement programs that have resulted in also being AS9100, TS16949 and ISO 14001 certified. In addition, Radiall is committed to investing in its people, future technologies and the environment, such as being RoHS (Restriction of Hazardous Substances) and REACH (Registration, Evaluation, Authorization and Restriction of Chemical substances) compliant.

www.radiall.com



	Page
General Information	
Introduction	4
Design	5
How to order	7
Test Bench Phase Stable TestPro Assemblies	8
TestPro 4.2 standard assemblies	9
TestPro 4.2 cable	10
Connectors compatible with TestPro 4.2	11
TestPro 3 standard assemblies	13
TestPro 3 cable	14
Connectors compatible with TestPro 3	15
TestPro 3 low profile cable	16
Connectors compatible with TestPro 3 low profile	17
Ultra Low Loss TestPro Assemblies	18
TestPro 5 & TestPro 8 standard assemblies	19
TestPro 5 cable	20
Connectors compatible with TestPro 5	21
TestPro 8 cable	23
Connectors compatible with TestPro 8	24
Accessories	26
Index	27



The TestPro product range is dedicated to **Test and Measurement applications** requiring excellent electrical performance, high mechanical endurance and excellent resistance to wear and corrosion.

We offer 2 product categories to meet your needs:

- **“Phase stable TestPro”** are suitable for test benches in production or labs, due to their long life and stability in dynamic use. Test cable assemblies are intended for daily use in components and assembly shops, test labs and automatic test equipment applications.

They differ from standard cable assemblies in the fact that they are especially designed for applications that require repeated connection/disconnection procedures, strenuous flexing situations and applications where phase, loss and VSWR stability becomes an issue.

- **“Ultra low loss”** allow the use of long length cables with remote test stations and anechoic chambers. Their high stability with temperature makes them easy to use in temperature chambers. They are also suitable for high power applications.

Our TestPro product range is designed to operate in the DC – 40 GHz frequency range depending on connector and cable choice. Optional protective jacket, offer different armor level.

Our **“ProJack”** is excellent for all defense systems tests running outdoors.

All components are designed and manufactured by Radiall in facilities operated under ISO9001-V2000/ASN9100 quality standards.

ONLINE WEBTOOL FOR QUICK SERVICE

To access our online tools and build the desired cable assembly, goto www.radiall.com/cableassembly

Select our “Test & Measurement” tool for TestPro cable assemblies.

This tool enables you to select from a list of standard assembly lengths, part numbers or to build your own TestPro assembly by selecting cable and connectors to meet your need. The TestPro tool also gives the performance of the desired cable assembly.

- Select standard assembly lengths or • build your assembly
- calculate performance



www.radiall.com



CABLE DESIGN and MANUFACTURING

The TestPro cable range benefits from Radiall's 30 years of experience in manufacturing high tech microwave cable for the military and aerospace markets. The TestPro cables were designed to meet test and measurement requirements.

Manufacturing is attained on Radiall's own design manufacturing machines.

Low density PTFE tape wrapping is the heart of our process. It elevates our Ultra Low Loss TestPro cable to the position of best performance in the market.

Our mastery in high precision multilayer braiding and wrapping makes the TestPro cable range stable over thousands of bending life cycles compared to the competition.

5000 MATING CYCLES GUARANTEED

TestPro cable assemblies for test applications were developed using new highly ruggedized stainless steel connectors. Our TestPro connectors are extremely robust. The combination of higher grade stainless steel and a unique attachment method offers a very reliable product over multiple matings.

Performance after 5,000 matings



- Low contact resistance variation <math>< 0.3 \text{ m}\Omega</math>
- Very stable VSWR 1.11 @ 18 GHz

CONNECTOR ATTACHMENT

The connector attachment is the main weakness, when using standard cable assemblies in test and measurement applications. Radiall TestPro connectors are designed with a unique attachment process which elevates the assembly ruggedness, provides high electrical stability, and a very long life.



ARMOR OPTION

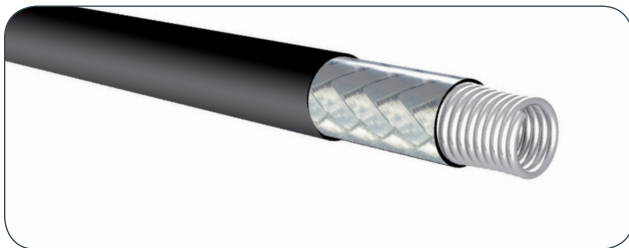

APPLICATION NOTE

Main benefits:

- high mechanical protection (resistance to crush, traction, abrasion, etc.)
- high flexibility
- anti-torque
- strain relief
- anti-kinking action
- secured watertightness when used with compound chamber

Radiall p/n: G940RP10 - G941RP10

• construction

	Material
Spring	stainless steel
Braid	stainless steel
Jacket	black PU

• mechanical characteristics

	For TestPro 4.2 and TestPro 5	For TestPro 8
Outer dia. (max)	11 mm (0.433 in.)	15 mm (0.590 in.)
Maximum weight	190 g/m (57.6 g/ft)	340 g/m (103 g/ft)
Min. bend radius	equal to cable bend radius	
Crush resistance	2 500 N / 100 mm	
Tensile strength	900 N	

• environmental characteristics

Temperature*	-55 / +100 ° C (-67 / +212° F)
Fire resistance	yes (FAR 25 853)
Halogen-free jacket	no

* operating temperature range

In many applications, specific assemblies are needed. The Radiall TestPro range is available in standard or custom lengths and configurations. Use the following pages to select a standard part number or make your choice of cable and connectors to meet your needs and send us your request for quotation.

HOW TO ORDER

Select the right TestPro cable.

- TestPro 3 and TestPro 4.2 “Phase stable” are suitable for test benches in production or labs, due to its long life and great stability in dynamic use.
- TestPro 5 and TestPro 8 “Ultra low loss” allow the use of long length cables with remote test stations and anechoic chambers. Their high stability with temperature makes them easy to use in temperature chambers. They are also suitable for high power applications.

Select armor option for reinforced cable assemblies.

TestPro 3 is internally armored. For TestPro 4.2, TestPro 5 and TestPro 8 optional protective jackets, “ProJack” offers high armor level. “ProJack” is excellent for all defense systems tests running outdoors. See detailed protective jacket characteristics in page 6.

Select connectors.

Select the right connectors compatible with your choice of TestPro cables.

Send quote requests to your Radiall sales contact.

You may also use our cable assembly builder at www.radiall.com

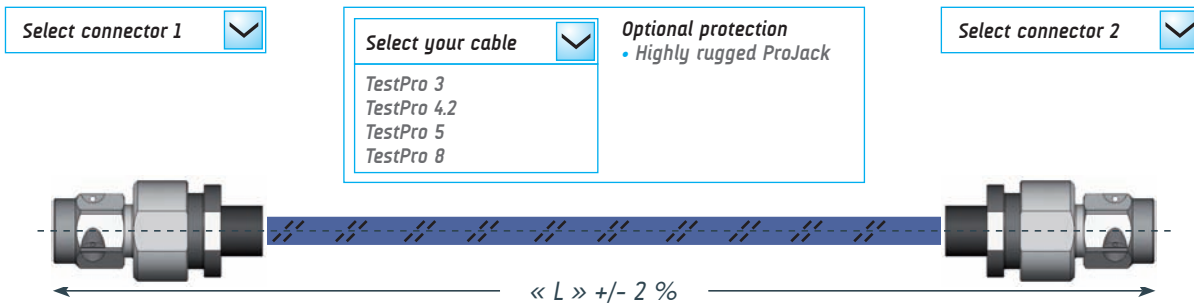

PHASE STABLE BENCH TEST CABLE ASSEMBLY

Properties	TestPro 4.2	TestPro 3 / TestPro 3 Low Profile
Frequency range	DC - 20 GHz	DC - 26.5 GHz and DC- 40 GHz
Impedance	50 Ω \pm 2 Ω	50 Ω \pm 1 Ω
IL (dB/m)	1.90 @ 18 GHz	2.41 @ 26.5 GHz - 3.11 @ 40 GHz
IL (dB/ft)	0.58 @ 18 GHz	0.73 @ 26.5 GHz - 0.94 @ 40 GHz
Phase with flexure stability	2° @ 18 GHz	2° @ 26.5 GHz - 5° @ 40 GHz
Amplitude stability (dB)	< 0.05 @ 18 GHz	< 0.1 @ 40 GHz
Shielding effectiveness	-110 dB min @ 1 GHz	-110 dB min @ 1 GHz
Crush resistance	135 lb/linear in.	260 lb/linear in. (*)
Minimum bend radius	25 mm (1 in.)	25 mm (1 in.)
Temperature (°C)	-55 / + 105 °C	-55 / + 125 °C
Connectors	SMA, N, TNC, PC7	SMA3.5, SMA2.9 (K), NMD2.9, TVAC2.9, 2.4MM
Flexure life cycle	10,000	20,000
Mating cycles durability	5,000	5,000
Aarmor	Available	Integrated
ROHS / REACH	Yes	Yes

(*) TestPro 3 low profile non-armored version is 23 lb/linear in.

Application note

TestPro cables are designed specifically for testing and measurement and combine outstanding electrical performance with a specially designed protection system. These ruggedized assemblies offer excellent durability while remaining exceptionally flexible. The unique connector attachment system and strong cable structure provide high tensile stress resistance to the entire assembly.

Key features & benefits



- Phase and loss stable with flexure
- Crush torque and tensile resistant
- Flexible design
- Long service life
- Longer calibration intervals
- Easy to configure to DUT

Standard assembly lengths available 24", 36", and 72".

Custom cable lengths are available with short lead times.

Typical applications include: test labs, production floor testing, anechoic chambers, thermal vacuum chambers, and nearfield scanners.

All TestPro cable assemblies are delivered in individual packaging and corresponding test report.

PHASE STABLE TEST BENCH CABLE ASSEMBLIES

Part number	Operating frequency	Connectors		Length	Attenuation-Typ. @2GHz - @18GHz	VSWR-Typ. @18GHz
R288940034	DC - 18 GHz	SMA male	SMA male	24 in. / 61 cm	0.47 dB - 1.51 dB	1.20
R288940060	DC - 18 GHz	SMA male	SMA female	24 in. / 61 cm	0.47 dB - 1.51 dB	1.20
R288940001	DC - 18 GHz	SMA male	SMA male	36 in. / 91 cm	0.64 dB - 2.14 dB	1.20
R288940002	DC - 18 GHz	SMA male	SMA male	48 in. / 122 cm	0.83 dB - 2.79 dB	1.20
R288940003	DC - 18 GHz	SMA male	SMA male	72 in. / 183 cm	1.19 dB - 4.07 dB	1.20
R288940035	DC - 18 GHz	SMA male	N Type (*)	24 in. / 61 cm	0.47 dB - 1.51 dB	1.25
R288940004	DC - 18 GHz	SMA male	N Type (*)	36 in. / 91 cm	0.64 dB - 2.14 dB	1.25
R288940005	DC - 18 GHz	SMA male	N Type (*)	48 in. / 122 cm	0.83 dB - 2.79 dB	1.25
R288940006	DC - 18 GHz	SMA male	N Type (*)	72 in. / 183 cm	1.19 dB - 4.07 dB	1.25
R288940007	DC - 18 GHz	N Type (*)	N Type (*)	36 in. / 91 cm	0.64 dB - 2.14 dB	1.25
R288940008	DC - 18 GHz	N Type (*)	N Type (*)	48 in. / 122 cm	0.83 dB - 2.79 dB	1.25
R288940009	DC - 18 GHz	N Type (*)	N Type (*)	72 in. / 183 cm	1.19 dB - 4.07 dB	1.25
R288940010	DC - 18 GHz	PC7	PC7	36 in. / 91 cm	0.64 dB - 2.14 dB	1.30
R288940011	DC - 18 GHz	PC7	PC7	48 in. / 122 cm	0.83 dB - 2.79 dB	1.30
R288940013	DC - 18 GHz	PC7	SMA male	36 in. / 91 cm	0.64 dB - 2.14 dB	1.30
R288940014	DC - 18 GHz	PC7	SMA male	48 in. / 122 cm	0.83 dB - 2.79 dB	1.30
R288940016	DC - 18 GHz	PC7	N Type (*)	36 in. / 91 cm	0.64 dB - 2.14 dB	1.30
R288940017	DC - 18 GHz	PC7	N Type (*)	48 in. / 122 cm	0.83 dB - 2.79 dB	1.30
0100900900914GX	DC - 18 GHz	TNC male	TNC male	36 in. / 91 cm	0.70 dB - 2.34 dB	1.30

(*) Quick turn N Type male connector. All TestPro cable assemblies are delivered in individual packaging with attached test report.

VSWR

Maximum VSWR	0-4 GHz		4-8 GHz		8-12.4 GHz		12.4-18 GHz	
	VSWR	dB	VSWR	dB	VSWR	dB	VSWR	dB
2 x SMA	1.12	25	1.20	21	1.20	21	1.25	19
2 x N	1.15	23	1.25	19	1.25	19	1.30	18
2 x PC7	1.25	19	1.30	18	1.30	18	1.35	16

This table gives value for assembly lengths between 200 to 5000 mm (8 to 196 in.)

TEMPERATURE DERATING

Attenuation at X°C = Attenuation (20°C) x (1 + (X - 20) x θ)

Ex: θ = 0.002 for copper and silver

CHARACTERISTICS



CONSTRUCTION / DIMENSIONS

	Material
Center conductor	solid SPCC ⁽¹⁾
Dielectric	solid PTFE ⁽²⁾
Inner shield	flat SPC tape
Interlayer	Aluminum-Polyimide tape
Outer shield	SPC braid
Jacket	clear FEP ⁽³⁾
Outer diameter	4.81 mm (0.190 inches)

- ⁽¹⁾ SPCC = Silver Plated Copper-Clad Steel
- ⁽²⁾ PTFE = Poly-TetraFluoroEthylene
- ⁽³⁾ FEP = Fluorinated Ethylene Propylene



ELECTRICAL CHARACTERISTICS

Characteristic impedance	50 ohms ± 2 ohms	
Operating frequency range	DC - 20 GHz	
Cut-off frequency	34 GHz	
Screening effectiveness	> 100 dB (at 18 GHz)	
Velocity of propagation	71 %	
Propagation time	4.75 ns / m	1.45 ns / ft
Capacitance	95 pF / m (at 1 GHz)	29 pF / ft (at 1 GHz)
Insulation resistance	> 3 x 10 ⁵ MOhm / m	
Nominal phase	1645 ° / m / GHz	
Phase stability with bending*	< 0.17° / 360° / GHz (at 18 GHz)	
Attenuation stability with bending*	< 0.015 dB (at 18 GHz)	
Attenuation stability with shaking	< 0.01 dB/m (at 18 GHz)	

* = the cable is coiled up 10 times onto a mandrel of 100 mm (3.94") diameter.

MECHANICAL CHARACTERISTICS

Maximum weight	60g / m	18.3g / ft
Recommend. min. bend radius	25 mm	0.98 inch
Crush resistance	> 2300N / 100 mm	

APPLICATION NOTE

TestPro 4.2 is a high frequency microwave cable that delivers good attenuation characteristics. This low loss triple-shielded cable provides the best combination of low attenuation and VSWR/loss/phase stability, when compared to similar size flexible cables. The TestPro 4.2 rugged structure is perfectly adapted for dynamic applications such as laboratory measurements when assembled with TestPro connectors.

ENVIRONMENTAL CHARACTERISTICS

Operating temperature range*	-55 / +200° C	-67 / +392° C
Fire resistance	yes	
Halogen-free jacket	no	

* cable alone. Cable assembly operating temperature range is -55 / +105°C (-67 / + 221°F)

FREQUENCY / ATTENUATION (typ.) / CW MAX POWER (*)

GHz	dB / m	dB / ft	Watts
1.0	0.41	0.12	550
2.0	0.60	0.18	295
4.0	0.87	0.26	210
8.0	1.29	0.39	150
12.4	1.67	0.51	120
18.0	2.10	0.64	95
20.0	2.24	0.68	80
Attenuation calculation (dB/m)	(0.384 x √F GHz) + (0.026 x F GHz)		

(*) = CW max power calculated at sea level / 40°C and VSWR 1:1
 (Power ratings may be limited by the connector type. Please contact us for specific needs).
 Note : typical attenuation for a couple of connectors (dB) = 0.0447 x √F (GHz) + 0.04

Connector part numbers are for indication only. Connectors and cables cannot be ordered separately.

SMA SERIES



Designation	Straight Plug
Item	M125064C00
Max. Freq	20 GHz

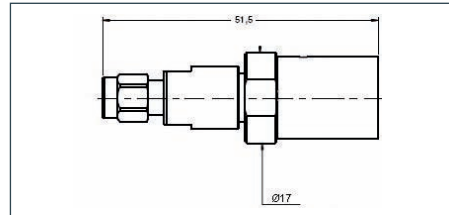

Designation	Straight Plug for ProJack
Item	M125064C01
Max. Freq	20 GHz

SMA Series characteristics:
 Voltage withstanding 750 Vrms
 Connector material is stainless steel.
 Finish is passivated
 Nominal coupling nut torque si 110 N
 Recommended torque wrench for plugs:
 R282320000 / 8 mm / 80-120 Ncm



Designation	Straight Jack
Item	M125207C00
Max. Freq	20 GHz

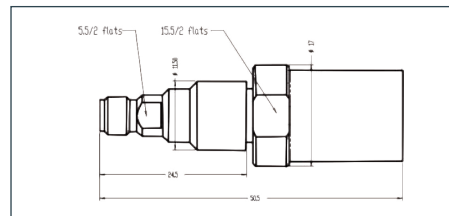

Designation	Straight Jack for ProJack
Item	M125207C01
Max. Freq	20 GHz

PC7 SERIES



Designation	Straight Plug
Item	M151064C00
Max. Freq	18 GHz

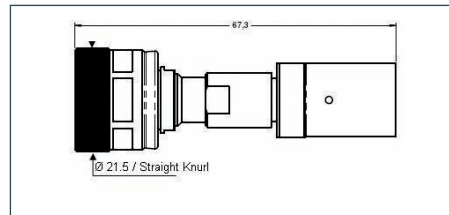

Designation	Straight Plug for ProJack
Item	M151064C01
Max. Freq	18 GHz

PC7 Series characteristics:
 Voltage withstanding 750 Vrms
 Connector material is stainless steel.
 Finish is passivated

CONNECTORS COMPATIBLE WITH



Connector part numbers are for indication only. Connectors and cables cannot be ordered separately.

N SERIES

Designation	Straight Plug	Designation	Straight Plug For ProJack
Item	M163064C00	Item	M163064C01
Max. Freq	18 GHz	Max. Freq	18 GHz

N Series characteristics:
 Voltage withstanding 750 Vrms
 Quick turn (1.5 full rotation to mate)
 Connector material is stainless steel.
 Finish is passivated.
 Nominal coupling nut torque is 400 N
 Recommended torque wrench:
 R282303000 / 19 mm / 160 Ncm

TNC SERIES

Designation	Straight Plug	Designation	Straight Plug For ProJack
Item	M143064C00	Item	M143064C01
Max. Freq	18 GHz	Max. Freq	18 GHz

TNC Series characteristics:
 Voltage withstanding 1500 Vrms
 Connector material is stainless steel.
 Finish is passivated.
 Nominal coupling nut torque is 330 N
 Recommended torque wrench:
 R282300000 / 14 mm / 265 Ncm

PHASE STABLE TEST BENCH CABLE ASSEMBLIES

Part number	Operating frequency	Connectors		Length	Attenuation-Typ. @2GHz - @Max F(GHz)	VSWR-Typ. @Max F(GHz)
1801171170610KE	DC - 26.5 GHz	SMA 3.5 male	SMA 3.5 male	24 in. / 61 cm	0.44 dB - 1.44 dB	1.27
1801171180610KE	DC - 26.5 GHz	SMA 3.5 male	SMA 3.5 female	24 in. / 61 cm	0.44 dB - 1.44 dB	1.27
1801171170914KE	DC - 26.5 GHz	SMA 3.5 male	SMA 3.5 male	36 in. / 91 cm	0.61 dB - 2.02 dB	1.27
1801171180914KE	DC - 26.5 GHz	SMA 3.5 male	SMA 3.5 female	36 in. / 91 cm	0.61 dB - 2.02 dB	1.27
1801171171219KE	DC - 26.5 GHz	SMA 3.5 male	SMA 3.5 male	48 in. / 122 cm	0.78 dB - 2.61 dB	1.27
1801171181219KE	DC - 26.5 GHz	SMA 3.5 male	SMA 3.5 female	48 in. / 122 cm	0.78 dB - 2.61 dB	1.27
1801171171829KE	DC - 26.5 GHz	SMA 3.5 male	SMA 3.5 male	72 in. / 183 cm	1.12 dB - 3.78 dB	1.27
1801171181829KE	DC - 26.5 GHz	SMA 3.5 male	SMA 3.5 female	72 in. / 183 cm	1.12 dB - 3.78 dB	1.27
1800920920610PJ	DC - 40 GHz	SMA 2.9 male	SMA 2.9 male	24 in. / 61 cm	0.44 dB - 1.76 dB	1.35
1800920930610PJ	DC - 40 GHz	SMA 2.9 male	SMA 2.9 female	24 in. / 61 cm	0.44 dB - 1.76 dB	1.35
1800920920914PJ	DC - 40 GHz	SMA 2.9 male	SMA 2.9 male	36 in. / 91 cm	0.61 dB - 2.46 dB	1.35
1800920930914PJ	DC - 40 GHz	SMA 2.9 male	SMA 2.9 female	36 in. / 91 cm	0.61 dB - 2.46 dB	1.35
1800920921219PJ	DC - 40 GHz	SMA 2.9 male	SMA 2.9 male	48 in. / 122 cm	0.78 dB - 3.19 dB	1.35
1800920931219PJ	DC - 40 GHz	SMA 2.9 male	SMA 2.9 female	48 in. / 122 cm	0.78 dB - 3.19 dB	1.35
1800920921829PJ	DC - 40 GHz	SMA 2.9 male	SMA 2.9 male	72 in. / 183 cm	1.12 dB - 4.62 dB	1.35
1800920931829PJ	DC - 40 GHz	SMA 2.9 male	SMA 2.9 female	72 in. / 183 cm	1.12 dB - 4.62 dB	1.35
1800940920914PJ	DC - 40 GHz	NMD 2.9	SMA 2.9 male	36 in. / 91 cm	0.61 dB - 2.46 dB	1.35
1800940930914PJ	DC - 40 GHz	NMD 2.9	SMA 2.9 female	36 in. / 91 cm	0.61 dB - 2.46 dB	1.35
1800940921219PJ	DC - 40 GHz	NMD 2.9	SMA 2.9 male	48 in. / 122 cm	0.78 dB - 3.19 dB	1.35
1800940931219PJ	DC - 40 GHz	NMD 2.9	SMA 2.9 female	48 in. / 122 cm	0.78 dB - 3.19 dB	1.35
1800940921829PJ	DC - 40 GHz	NMD 2.9	SMA 2.9 male	72 in. / 183 cm	1.12 dB - 4.62 dB	1.35
1800940931829PJ	DC - 40 GHz	NMD 2.9	SMA 2.9 female	72 in. / 183 cm	1.12 dB - 4.62 dB	1.35

2.4MM connectors available soon, please consult us.

All TestPro cable assemblies are delivered in individual packaging with attached test report.

THERMAL VACUUM

All configurations excepted NMD2.9 are available with vented connectors for TVAC applications.

VSWR

Maximum VSWR	0-4 GHz		4-12.4 GHz		12.4-18 GHz		18-26.5 GHz		26.5-32 GHz		32-40 GHz	
	VSWR	dB	VSWR	dB	VSWR	dB	VSWR	dB	VSWR	dB	VSWR	dB
2 x SMA3.5	1.15	23.1	1.20	20.8	1.25	19.1	1.30	17.7	-	-	-	-
2 x SMA2.9 (K)	1.15	23.1	1.20	20.8	1.25	19.1	1.27	18.5	1.35	16.5	1.35	15.6

This table gives value for assembly lengths between 200 to 5000 mm (8 to 196 in.)

TEMPERATURE DERATING

Attenuation at X°C = Attenuation (20°C) x (1 + (X - 20) x θ). Ex: θ = 0.002 for copper and silver

CONSTRUCTION / DIMENSIONS

	Material
Center conductor	SPCCS ⁽¹⁾
Dielectric	PTFE ⁽²⁾
Electrical shield	SPC ⁽³⁾
Interlayer	aluminum-polyimide
Inner braid	SPC ⁽³⁾
Inner jacket	PFA ⁽⁴⁾
Crush protection	stainless steel
Strength braid	stainless steel
Outer jacket	fibrillated braid
Outer diameter	7.04 mm (0.277 inches)

- ⁽¹⁾ SPCCS = Silver Plated Copper-Clad Steel
- ⁽²⁾ PTFE = Poly-TetraFluoroEthylene
- ⁽³⁾ SPC = Silver-Plated Copper
- ⁽⁴⁾ PFA = PerFluoroAlkoxy



ELECTRICAL CHARACTERISTICS

Characteristic impedance	50 ohms ± 1 ohms	
Operating frequency range	DC - 40 GHz	
Cut-off frequency	44 GHz	
Screening effectiveness	> 110 dB at 1 GHz; > 90dB at 18 GHz	
Velocity of propagation	76 %	
Propagation time	4.4 ns / m	1.3 ns / ft
Capacitance	88 pF / m (at 1 GHz)	26.7 pF / ft (at 1 GHz)
Insulation resistance	> 3 x 10 ⁵ MOhm / m	
Corona extinction voltage	-	
Nominal phase	1590 ° / m / GHz	
Phase stability with temperature	< 4° / m / GHz; <2820ppm (-55 / +125°C)	
Phase stability with bending**	5° Typ. / 9.5° Max. (at 40 GHz)	
Attenuation stability with bending**	< 0.1 dB (at 40 GHz)	
Attenuation stability with shaking	< 0.03 dB/m (at 40 GHz)	
Atten. variation with temperature	Att. (at X° C) = att. (at 20° C) x (1 + (X - 20) x 0.002)	

** according to IEC966-1, bending method n°2

MECHANICAL CHARACTERISTICS

Maximum weight	150 g / m	46.3 g / ft
Recommend. min. bend radius	25 mm	0.984 inch
Crush resistance	> 4,400 N / 100 mm (260 lb per linear inch)	
Flex life cycle	20,000 (IEC 966-1 section 9.3)	
Tensile strength	200 N	

APPLICATION NOTE

TestPro 3 is a 40 GHz measurement cable. It combines electrical advantages and integrated protection system. These ruggedized assemblies offer excellent durability while remaining exceptionally flexible, a unique connector attachment system and strong cable.

ENVIRONMENTAL CHARACTERISTICS

Operating temperature range*	-55 / +200 ° C	-67 / +392 ° F
Fire resistance	yes (MIL C 87104)	
Abrasion resistance	yes (SAE AS5756, edge 0.5 mm, load 2 pounds)	
Halogen-free jacket	no	
ROHS / REACH	yes	

* cable alone. Cable assembly operating temperature range is -55 / + 125 °C (-67 / +257°F)

FREQUENCY / ATTENUATION (typ.) / CW MAX POWER (*)

GHz	dB / m	dB / ft	Watts
1.0	0.39	0.12	400
2.0	0.56	0.17	280
4.0	0.81	0.25	200
6.0	1.01	0.31	160
8.0	1.19	0.36	140
12.4	1.53	0.46	120
18.0	1.91	0.58	90
26.5	2.41	0.73	80
40.0	3.11	0.94	60
Attenuation calculation (dB/m)	Typ: (0.365 x √F GHz) + (0.02 x F GHz)		

(*) = CW max power calculated at sea level / 40°C and VSWR 1:1
 (Power ratings may be limited by the connector type. Please contact us for specific needs).
 Note : typical attenuation for a couple of connectors (dB) = 0.0447 x √F (GHz) + 0.04

Connector part numbers are for indication only. Connectors and cables cannot be ordered separately.

SMA 3.5 SERIES



Designation	Straight Plug
Item	R127900001
Max. Freq	26.5 GHz



Designation	Straight Jack
Item	R127920001
Max. Freq	26.5 GHz

SMA 3.5 Series characteristics:
 Voltage withstanding 750 Vrms
 Connector material is stainless steel.
 Finish is passivated
 Nominal coupling nut torque is 110 N
 Recommended torque wrench for plugs:
 R282320000 / 8 mm / 80-120 Ncm

SMA2.9 (K) SERIES



Designation	Straight Jack
Item	R127801321
Max. Freq	40 GHz



Designation	Straight Jack
Item	R127822111
Max. Freq	40 GHz

SMK Series characteristics:
 Voltage withstanding 750 Vrms.
 Connector material is stainless steel.
 Finish is passivated.
 Nominal coupling nut torque is 110 N.
 Recommended torque wrench for plugs:
 R282320000 / 8 mm / 80-120 Ncm



Designation	NMD 2.9 port femal
Item	R299776101
Max. Freq	40 GHz

VENTED CONNECTORS SMA2.9 (K) SERIES



Designation	Vented Straight Plug
Item	R127801311
Max. Freq	40 GHz



Designation	Vented Straight Plug
Item	R127822101
Max. Freq	40 GHz

2.4MM CONNECTORS

Please consult us.

CABLE CHARACTERISTICS



CONSTRUCTION / DIMENSIONS

	Material
Center conductor	SPCCS ⁽¹⁾
Dielectric	PTFE ⁽²⁾
Electrical shield	SPC ⁽³⁾
Interlayer	aluminum-polyimide
Strength braid	SPC ⁽³⁾
Outer jacket	PFA ⁽⁴⁾
Outer diameter	3,95 mm (0,156 inches)

- ⁽¹⁾ SPCCS = Silver Plated Copper-Clad Steel
- ⁽²⁾ PTFE = Poly-TetraFluoroEthylene
- ⁽³⁾ SPC = Silver-Plated Copper
- ⁽⁴⁾ PFA = PerFluoroAlkoxy

ELECTRICAL CHARACTERISTICS

Characteristic impedance	50 ohms ± 1 ohms	
Operating frequency range	DC - 40 GHz	
Cut-off frequency	44 GHz	
Screening effectiveness	> 110 dB at 1 GHz; > 90dB at 18 GHz	
Velocity of propagation	76 %	
Propagation time	4,4 ns / m	1,3 ns / ft
Capacitance	88 pF / m (at 1 GHz)	26,7 pF / ft (at 1 GHz)
Insulation resistance	> 3 x 10 ⁵ MOhm / m	
Corona extinction voltage	-	
Nominal phase	1590 ° / m / GHz	
Phase stability with temperature	< 4° / m / GHz; <2820ppm (-55 / +125°C)	
Phase stability with bending**	5° Typ. / 9,5° Max. (at 40 GHz)	
Attenuation stability with bending**	< 0,1 dB (at 40 GHz)	
Attenuation stability with shaking	< 0,03 dB/m (at 40 GHz)	
Atten. variation with temperature	Att. (at X° C) = att. (at 20° C) x (1 + (X - 20) x 0,002)	

** according to IEC966-1, bending method n°2



MECHANICAL CHARACTERISTICS

Maximum weight	50 g / m	15,3 g / ft
Recomm. min. bend radius	25 mm	0,984 inch
Crush resistance	> 400 N / 100 mm (23 lb per linear inch)	
Flex life cycle	20,000 (IEC 966-1 section 9.3)	
Tensile strength	200 N	

APPLICATION NOTE

TestPro 3 is a 40GHz measurement cable. It combines electrical advantages and integrated protection system. These ruggedized assemblies offer excellent durability while remaining exceptionally flexible, a unique connector attachment system and strong cable.

ENVIRONMENTAL CHARACTERISTICS

Operating temperature range*	-55 / +200 ° C	-67 / +392 ° F
Fire resistance	yes (MIL C 87104)	
Halogen-free jacket	no	
ROHS / REACH	yes	

* cable alone. Cable assembly operating temperature range is -55 / + 125 °C (-67 / +257°F)

FREQUENCY / ATTENUATION (typ.) / CW MAX POWER (*)

GHz	dB / m	dB / ft	Watts
1.0	0.39	0.12	400
2.0	0.56	0.17	280
4.0	0.81	0.25	200
6.0	1.01	0.31	160
8.0	1.19	0.36	140
12.4	1.53	0.46	120
18.0	1.91	0.58	90
26.5	2.41	0.73	80
40.0	3.11	0.94	60
Attenuation calculation (dB/m)		Typ: (0.365 x √F GHz) + (0.02 x F GHz)	

(*) = CW max power calculated at sea level / 40°C and VSWR 1:1
 (Power ratings may be limited by the connector type. Please contact us for specific needs.)
 Note : typical attenuation for a couple of connectors (dB) = 0.0447 x √F (GHz) + 0.04

Connector part numbers are for indication only. Connectors and cables cannot be ordered separately.

SMA 3.5 SERIES



Designation	Straight Plug
Item	R127900011
Max. Freq	26.5 GHz



Designation	Straight Jack
Item	R127920011
Max. Freq	26.5 GHz

SMA 3.5 Series characteristics:
 Voltage withstanding 750 Vrms
 Connector material is stainless steel.
 Finish is passivated
 Nominal coupling nut torque is 110 N
 Recommended torque wrench for plugs:
 R282320000 / 8 mm / 80-120 Ncm

SMA2.9 (K) SERIES

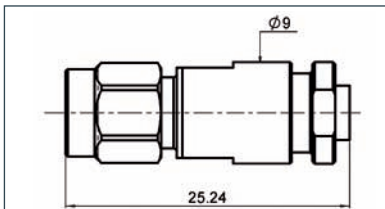

Designation	Straight Plug
Item	R127801331
Max. Freq	40 GHz

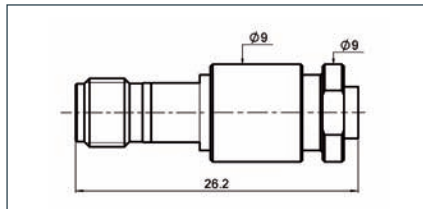

Designation	Straight Jack
Item	R127822121
Max. Freq	40 GHz

SMA2.9 (K) Series characteristics:
 Voltage withstanding 750 Vrms
 Connector material is stainless steel.
 Finish is passivated
 Nominal coupling nut torque is 110 N
 Recommended torque wrench for plugs:
 R282320000 / 8 mm / 80-120 Ncm

2.4MM CONNECTORS

Please consult us.

ULTRA LOW LOSS BENCH TEST CABLE ASSEMBLY

Properties	TestPro 5	TestPro 8
Frequency range	DC - 26.5 GHz	DC - 18 GHz
Impedance	50 $\Omega \pm 1 \Omega$	50 $\Omega \pm 1 \Omega$
IL (dB/m)	1.02 @ 18 GHz	0.68 @ 18 GHz
IL (dB/ft)	0.31 @ 18 GHz	0.21 @ 18 GHz
Phase with flexure stability	7.2° @ 18 GHz	7.2° @ 18 GHz
Amplitude stability (dB)	< 0.05 @ 18 GHz	< 0.05 @ 18 GHz
Shielding Effectiveness	-110 dB min @ 1 GHz	-110 dB min @ 1 GHz
Crush resistance	40 lb/linear in.	60 lb/linear in.
Minimum bend radius	25 mm (1 in.)	40 mm (1.6 in.)
Temperature (°C)	-55 / + 125 °C	-55 / + 125 °C
Connectors	SMA, N, TNC	SMA, N, TNC
Flexure life cycle	5,000	5,000
Mating cycles durability	5,000	5,000
Armor	Available	Available
ROHS / REACH	Yes	Yes

Application note

TestPro 5 and TestPro 8 benefit from Radiall's 30 years of expertise in manufacturing ultra low loss microwave cables. Radiall's mastery of low density PTFE tape wrapping elevates TestPro 5 and TestPro 8 to the position of best performance in the market.

To meet test and measurement requirements, these cables are reinforced. They are terminated with ruggedized TestPro connectors. The combination of the unique center contact captivation system and attachment methods offers very reliable products over multiple matings.

TestPro ultra low loss test and measurement cables are required when loss becomes an issue. Their high stability with temperature makes them easy to use in temperature chambers. They are also suitable for high power applications.

Key features & benefits



- Ultra low loss
- High phase stability with temperature
- Strain relief
- Crush resistance
- Very precise phase matching
- Long length available

Standard available assembly length: 39 inches

Custom lengths available with short lead time.

Typical applications include: test labs, production floor testing, anechoic chambers.

All TestPro cable assemblies are delivered in individual packaging with attached test report.

ULTRA LOW LOSS TEST CABLE ASSEMBLIES

Part number	Operating frequency	Connectors		Length	Attenuation-Nom @2GHz - @18GHz	VSWR-Nom @18GHz
TestPro 5						
R288931001	DC - 26.5 GHz	SMA male	SMA female	39.4 in. / 100 cm	0.42 dB - 1.25 dB	1.20
R288931002	DC - 18 GHz	N male	N male	39.4 in. / 100 cm	0.42 dB - 1.25 dB	1.25
R288931003	DC - 18 GHz	N male	SMA male	39.4 in. / 100 cm	0.42 dB - 1.25 dB	1.25
TestPro 8						
R288931004	DC - 18 GHz	SMA male	SMA female	39.4 in. / 100 cm	0.31 dB - 0.91 dB	1.25
R288931005	DC - 18 GHz	N male	N male	39.4 in. / 100 cm	0.31 dB - 0.91 dB	1.25
R288931006	DC - 18 GHz	N male	SMA male	39.4 in. / 100 cm	0.31 dB - 0.91 dB	1.25

TNC male connector also available. All TestPro cable assemblies are delivered in individual packaging with attached test report.

VSWR

Maximum VSWR	0-4 GHz		4-8 GHz		8-12.4 GHz		12.4-18 GHz	
	VSWR	dB	VSWR	dB	VSWR	dB	VSWR	dB
TestPro 5								
2 x SMA (*)	1.15	23	1.20	21	1.20	21	1.25	19
2 x TNC	1.20	21	1.20	21	1.20	21	1.35	17
2 x N	1.20	21	1.25	19	1.25	19	1.30	18
TestPro 8								
2 x SMA	1.15	23	1.20	21	1.20	21	1.25	19
2 x TNC	1.20	21	1.20	21	1.20	21	1.35	17
2 x N	1.20	21	1.25	19	1.25	19	1.30	18

This table gives values for assembly lengths between 200 to 5000 mm (8 to 196 in.) with straight connectors.

(*) @26.5 GHz VSWR = 1.27 - 18 dB

POWER HANDLING

TestPro 5 & 8 are particularly well suited for Ultra Low Loss and high power applications.

Max power handling is related to connector configurations and customer applications.

Please specify the working frequency, temperature and altitude/pressure.

For more detailed information please consult with Radiall directly.

TEMPERATURE DERATING

Attenuation at X°C = Attenuation (20°C) x (1 + (X - 20) x θ). Ex: θ = 0.002 for copper and silver

CONSTRUCTION / DIMENSIONS

	Material
Center conductor	solid SPC ⁽¹⁾
Dielectric	low density PTFE ⁽²⁾
Inner shield	SPC tape
Outer shield	SPC braid
Jacket	green FEP ⁽³⁾
Outer diameter	5.85 mm (0.230 inches)

- ⁽¹⁾ SPC = Silver-Plated Copper
⁽²⁾ PTFE = Poly-TetraFluoroEthylene
⁽³⁾ FEP = Fluorinated Ethylene Propylene



ELECTRICAL CHARACTERISTICS

Characteristic impedance	50 ohms ± 1 ohms	
Operating frequency range	DC - 26.5 GHz	
Cut-off frequency	31 GHz	
Screening effectiveness	> 90 dB (at 18 GHz)	
Velocity of propagation	85 %	
Propagation time	3.9 ns / m	1.2 ns / ft
Capacitance	79 pF / m (at 1 GHz)	23.9 pF / ft (at 1 GHz)
Insulation resistance	> 3 x 10 ⁵ MOhm / m	
Corona extinction voltage	> 2.3 kV	
Nominal phase	1400 ° / m / GHz	
Phase stability with temperature	< 1° / m / GHz (-55 / +100°C)	
Phase stability with bending	< 0.4° / 360° / GHz	
Attenuation stability with bending	< 0.05 dB (at 18 GHz) / < 0.1 dB (at 26.5 GHz)	
Attenuation stability with shaking	< 0.01 dB/m (at 18 GHz) / < 0.015 dB/m (at 26.5 GHz)	
Atten. variation with temperature	Att. (at X° C) = att. (at 20° C) x 1 + (X - 20) x 0.002	

APPLICATION NOTE

This ultra- low loss cable is fully adapted to laboratory applications. It can be reinforced with the "ProJack" protective jacket for high mechanical stress applications.

Main benefits:

- ultra- low loss
- high electrical stability with bending and temperature
- high phase stability with temperature
- strain relief
- high mechanical strength and crush resistance
- broad range of connectors available

MECHANICAL CHARACTERISTICS

Maximum weight	73g / m	22.1g / ft
Recommend. min. bend radius	25 mm	0.984 inch
Crush resistance	> 700N / 100 mm	

ENVIRONMENTAL CHARACTERISTICS

Operating temperature range*	-70 / +200° C	-94 / +392° C
Fire resistance	yes (MIL C 87104)	
Halogen-free jacket	no	

* cable alone. Cable assembly operating temperature range is -55 / +125°C (-67 / + 257°F)

FREQUENCY / ATTENUATION (typ.) / CW MAX POWER (*)

GHz	dB / m	dB / ft	Watts
1.0	0.23	0.07	850
2.0	0.32	0.10	600
4.0	0.46	0.14	420
6.0	0.57	0.17	340
8.0	0.66	0.20	300
10.0	0.75	0.23	270
12.4	0.84	0.25	240
18.0	1.02	0.31	200
26.5	1.27	0.38	190
Attenuation calculation (dB/m)	(0.22 x √f GHz) + (0.005 x f GHz)		

* = CW max power calculated at sea level / 40°C and VSWR 1:1 (Cable-assembly power ratings may be limited by the connector type. Please contact us for specific needs).
 Note: typical attenuation for two connectors (dB) = 0.045 x √f GHz + 0.04

Connector part numbers are for indication only. Connectors and cables cannot be ordered separately.

SMA SERIES

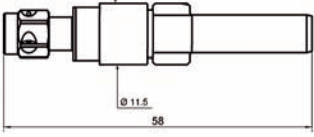
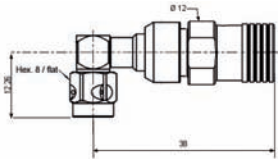
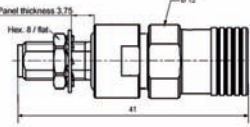
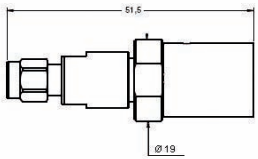
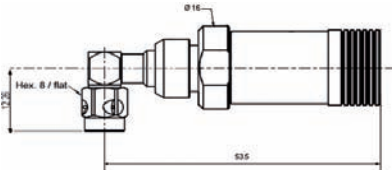
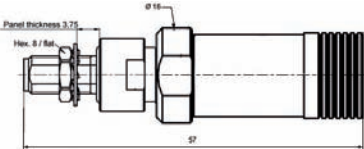
		
Designation Straight Plug	Designation Right Angle Plug	Designation Straight Jack
Item Max. Freq	Item Max. Freq	Item Max. Freq Miscellaneous
M125065C00 26.5 GHz	M125195L02 18 GHz	M125330L02 26.5 GHz Panel sealed panel nut torque 200N
		
Designation Straight Plug For ProJack	Designation Right Angle Plug For ProJack	Designation Straight Jack For ProJack
Item Max. Freq	Item Max. Freq	Item Max. Freq Miscellaneous
M125065C03 26.5 GHz	M125195L03 18 GHz	M125330L03 26.5 GHz Panel sealed panel nut torque 200N

SMA Series characteristics:

Voltage withstanding 1000 Vrms. Connector material is stainless steel. Finish is passivated.

Nominal coupling nut torque is 110 N (recommended torque wrench for plugs: R28220000 / 8 mm / 80-120 Ncm)

TNC SERIES

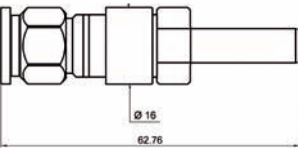
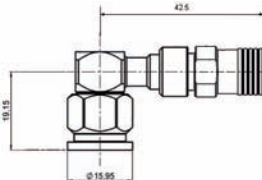
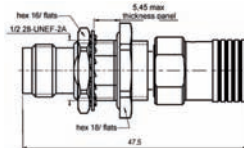
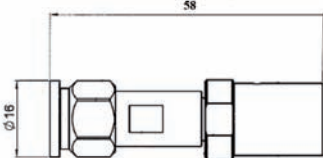
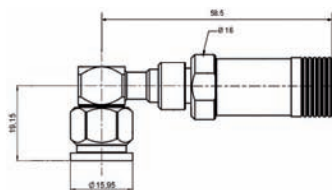
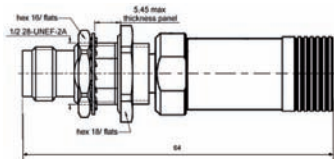
		
Designation Straight Plug	Designation Right Angle Plug	Designation Straight Jack
Item Max. Freq	Item Max. Freq	Item Max. Freq Miscellaneous
M143065C00 18 GHz	M143195L02 18 GHz	M143330L02 18 GHz Panel sealed panel nut torque 370N
		
Designation Straight Plug For ProJack	Designation Right Angle Plug For ProJack	Designation Straight Jack For ProJack
Item Max. Freq	Item Max. Freq	Item Max. Freq Miscellaneous
M143065C03 18 GHz	M143195L03 18 GHz	M143330L03 18 GHz Panel sealed panel nut torque 370N

TNC Series characteristics:

Voltage withstanding 1500 Vrms. Connector material is stainless steel. Finish is passivated.

Nominal coupling nut torque is 330 N (recommended torque wrench for plugs: R282300000 / 14 mm / 265 Ncm).

CONNECTORS COMPATIBLE WITH



Connector part numbers are for indication only. Connectors and cables cannot be ordered separately.

N 18 SERIES

N 18 Series characteristics:

Voltage withstanding 1500 Vrms

Connector material is stainless steel. Finish is passivated

Nominal coupling nut torque is 400 N (recommended torque wrench for plugs : R282303000 / 19 mm / 160 Ncm)

Designation	Straight Plug	Designation	Straight Plug For ProJack
Item	M163065C00	Item	M163065C03
Max. Freq	18 GHz	Max. Freq	18 GHz
Designation	Straight Jack	Designation	Straight Jack For ProJack
Item	M163325L02	Item	M163325L03
Max. Freq	18 GHz	Max. Freq	18 GHz
Miscellaneous	Panel sealed panel nut torque 500N	Miscellaneous	Panel sealed panel nut torque 500N
Designation	Right Angle Plug For ProJack	Designation	Right Angle Plug
Item	M163195L03	Item	M163195L02
Max. Freq	18 GHz	Max. Freq	18 GHz

CONSTRUCTION / DIMENSIONS

	Material
Center conductor	solid SPC ⁽¹⁾
Dielectric	low density PTFE ⁽²⁾
Inner shield	SPC tape
Outer shield	SPC braid
Jacket	green FEP ⁽³⁾
Outer diameter	8.50 mm (0.335 inches)

- ⁽¹⁾ SPC = Silver-Plated Copper
⁽²⁾ PTFE = Poly-TetraFluoroEthylene
⁽³⁾ FEP = Fluorinated Ethylene Propylene

ELECTRICAL CHARACTERISTICS

Characteristic impedance	50 ohms ± 1 ohms	
Operating frequency range	DC - 18 GHz	
Cut-off frequency	20 GHz	
Screening effectiveness	> 90 dB (at 18 GHz)	
Velocity of propagation	85 %	
Propagation time	3.9 ns / m	1.2 ns / ft
Capacitance	79 pF / m (at 1 GHz)	23.9 pF / ft (at 1 GHz)
Insulation resistance	> 3 x 10 ⁵ MOhm / m	
Corona extinction voltage	> 3.3 kV	
Nominal phase	1400 ° / m / GHz	
Phase stability with temperature	< 1° / m / GHz (-55 / +100°C)	
Phase stability with bending	< 0.4° / 360° / GHz	
Attenuation stability with bending	< 0.05 dB (at 18 GHz)	
Attenuation stability with shaking	< 0.01 dB/m (at 18 GHz)	
Atten. variation with temperature	Att. (at X° C) = att. (at 20° C) x 1 + (X - 20) x 0.002	

MECHANICAL CHARACTERISTICS

Maximum weight	155g / m	47.0g / ft
Recommend. min. bend radius	40 mm	1.575 inch
Crush resistance	> 1000N / 100 mm	

APPLICATION NOTE

This Ultra- low loss cable is fully adapted to laboratory applications. It can be reinforced with the "ProJack" protective jacket for high mechanical stress applications.

Main benefits:

- ultra- low loss
- high electrical stability with bending and temperature
- high phase stability with temperature
- strain relief
- high mechanical strength and crush resistance
- broad range of connectors available

ENVIRONMENTAL CHARACTERISTICS

Operating temperature range*	-70 / +200° C	-94 / +392° C
Fire resistance	yes (MIL C 87104)	
Halogen-free jacket	no	

* cable alone. Cable assembly operating temperature range is -55 / +125°C (-67 / +257°F)

FREQUENCY / ATTENUATION (typ.) / CW MAX POWER (*)

GHz	dB / m	dB / ft	Watts
1.0	0.15	0.04	1600
2.0	0.21	0.06	1100
3.0	0.26	0.08	920
4.0	0.30	0.09	800
5.0	0.34	0.10	710
6.0	0.37	0.11	650
8.0	0.44	0.13	560
10.0	0.49	0.15	500
12.4	0.55	0.17	450
18.0	0.68	0.21	380
Attenuation calculation (dB/m)	(0.14 x √F GHz) + (0.005 x F GHz)		

* = CW max power calculated at sea level / 40°C and VSWR 1:1 (Cable-assembly power ratings may be limited by the connector type. Please contact us for specific needs.)
 Note: typical attenuation for two connectors (dB) = 0.0447 x √F GHz + 0.04

Connector part numbers are for indication only. Connectors and cables cannot be ordered separately.

SMA SERIES

Designation Straight Plug	Designation Right Angle Plug	Designation Straight Jack
Item M125068C00 Max. Freq 18 GHz	Item M125199L04 Max. Freq 18 GHz	Item M125338L04 Max. Freq 18 GHz Miscellaneous Panel sealed panel nut torque 250N
Designation Straight Plug For ProJack	Designation Right Angle Plug For ProJack	Designation Straight Jack For ProJack
Item M125068C05 Max. Freq 18 GHz	Item M125199L05 Max. Freq 18 GHz	Item M125338L05 Max. Freq 18 GHz Miscellaneous Panel sealed panel nut torque 250N

SMA Series characteristics:

Voltage withstanding 1000 Vrms. Connector material is stainless steel.

Finish is passivated.

Nominal coupling nut torque is 110 N (recommended torque wrench for plugs : R282320000 / 8 mm / 80-120 Ncm)

TNC SERIES

Designation Straight Plug	Designation Right Angle Plug	Designation Straight Jack
Item M143068C00 Max. Freq 18 GHz	Item M143198L04 Max. Freq 18 GHz	Item M143338L04 Max. Freq 18 GHz Miscellaneous Panel sealed panel nut torque 370N
Designation Straight Plug For ProJack	Designation Right Angle Plug For ProJack	Designation Straight Jack For ProJack
Item M143068C05 Max. Freq 18 GHz	Item M143198L05 Max. Freq 18 GHz	Item M143338L05 Max. Freq 18 GHz Miscellaneous Panel sealed panel nut torque 370N

TNC Series characteristics:

Voltage withstanding 1500 Vrms.

Connector material is stainless steel. Finish is passivated.

Nominal coupling nut torque is 330 N (recommended torque wrench for plugs: R282300000 / 14 mm / 265 Ncm)

Connector part numbers are for indication only. Connectors and cables cannot be ordered separately.

N 18 SERIES

N 18 Series characteristics:
 Voltage withstanding 1500 Vrms
 Connector material is stainless steel.
 Finish is passivated.
 Nominal coupling nut torque is 400 N
 (recommended torque wrench for plugs:
 R282303000 / 19 mm / 160 Ncm)

Designation	Straight Plug	Designation	Straight Plug For ProJack
Item	M163068C00	Item	M163068C05
Max. Freq	18 GHz	Max. Freq	18 GHz
Designation	Straight Jack	Designation	Straight Jack For ProJack
Item	M163328L04	Item	M163328L05
Max. Freq	18 GHz	Max. Freq	18 GHz
Miscellaneous	Panel sealed panel nut torque 500N	Miscellaneous	Panel sealed panel nut torque 500N
Designation	Right Angle Plug For ProJack	Designation	Right Angle Plug
Item	M163198L05	Item	M163198L04
Max. Freq	18 GHz	Max. Freq	18 GHz

IN-SERIES ADAPTORS (DC-18 GHZ)



Interface	Male - Male	Male - Female	Female - Female	Miscellaneous
SMA	R125703000 R125703001	R125704000 R125704001	R125705000 R125705001	Gold-plated stainless steel Passivated stainless steel
TNC 18	R143703700	R143705700	R143704700 R143710700 R143730700	Square flange Bulkhead
N 18	R163703001	R163708001	R163705001	Silicon gasket

BETWEEN SERIES ADAPTORS (DC-18 GHZ)



Interface		PC7	N 18		
			Male	Female	Female bulkhead panel sealed
SMA	Male	R191009000			
	Female	R191011000			
PC 3.5	Male	R191010000	R191324000	R191326000	
	Female	R191012000	R191328000	R191330000	R191333000

ATTENUATORS



Interface m/f	Average power (W)	Frequency (GHz)							
		3	4	6	8	12.4	18	26.5	40
N	1			R4127xx124					
	2					R4147xx000	R4147xx161		
	15					R4157xx000	R4160xx000		
QMA	1			R4117xx124					
SMA	1			R4118xx124 (*)					
	2		R4138xx115 (**)				R4118xx121 (*)	R4138xx121 (*)	
	15					R4153xx000	R4161xx000		
SMA2.9	2								R4133xx000
TNC	1	R4125xx124							
	2						R4145xx000	R4145xx161	
	15					R4155xx000	R4168xx000		

xx for attenuation. Typical values are 03, 06, 10, 20, 30. For other attenuation value please consult us.

High power attenuators available (up to 100W)

BNC and 7/16 interface available

* .75 in. attenuators

** .86 in. attenuators

TERMINATIONS



Interface		Average power (W)	Frequency (GHz)				
			4	12.4	18	26.5	40
N	male	1	R404131000	R404240000			
	female		R404132000	R404245000			
QMA	male	1	R404114000				
	female	2			R404340000 R404355000		
QN	male	1	R404116000				
	female	1	R404101000 R404102000				
SMA	male	2			R404210000	R404213000 R404219000	
	female						
SMA2.9	male	1					R404280000 R404285000
	female						
TNC	male	1	R404121000 R404122000	R404225000			
	female						
TNC	male	2			R404370000 R404375000		
	female						

Medium and high power terminations also available (6 to 1000 W)

Part number	Page	Part number	Page	Part number	Page
0100900900914GX	9	M125207C00	11	R127900001	15
1800920920610PJ	13	M125207C01	11	R127900011	17
1800920920914PJ	13	M143064C00	12	R127920001	15
1800920921219PJ	13	M143064C01	12	R127920011	17
1800920921829PJ	13	M151064C00	11	R143703700	26
1800920930610PJ	13	M151064C01	11	R143704700	26
1800920930914PJ	13	M163064C00	12	R143705700	26
1800920931219PJ	13	M163064C01	12	R143710700	26
1800920931829PJ	13			R143730700	26
1800940920914PJ	13	R288931001	19	R163703001	26
1800940921219PJ	13	R288931002	19	R163705001	26
1800940921829PJ	13	R288931003	19	R163708001	26
1800940930914PJ	13	R288931004	19	R191009000	26
1800940931219PJ	13	R288931005	19	R191010000	26
1800940931829PJ	13	R288931006	19	R191011000	26
1801171170610PJ	13	R288940001	9	R191012000	26
1801171170914PJ	13	R288940002	9	R191324000	26
1801171171219PJ	13	R288940003	9	R191326000	26
1801171171829PJ	13	R288940004	9	R191328000	26
1801171180610PJ	13	R288940005	9	R191330000	26
1801171180914PJ	13	R288940006	9	R191333000	26
1801171181219PJ	13	R288940007	9		
1801171181829PJ	13	R288940008	9	R299776101	15
		R288940009	9		
G940RP10	6	R288940010	9	R404101000	26
G941RP10	6	R288940011	9	R404102000	26
		R288940013	9	R404114000	26
M125065C00	21	R288940014	9	R404116000	26
M125065C03	21	R288940016	9	R404121000	26
M125068C00	24	R288940017	9	R404122000	26
M125068C05	24	R288940034	9	R404131000	26
M125195L02	21	R288940035	9	R404132000	26
M125195L03	21	R288940060	9	R404210000	26
M125199L04	24			R404213000	26
M125199L05	24	R4117xx124	26	R404219000	26
M125330L02	21	R4118xx121	26	R404225000	26
M125330L03	21	R4118xx124	26	R404240000	26
M125338L04	24	R4125xx124	26	R404245000	26
M125338L05	24	R4127xx124	26	R404280000	26
M143065C00	21	R4133xx000	26	R404285000	26
M143065C03	21	R4138xx115	26	R404340000	26
M143068C00	24	R4138xx121	26	R404355000	26
M143068C05	24	R4145xx000	26	R404370000	26
M143195L02	21	R4145xx161	26	R404375000	26
M143195L03	21	R4147xx000	26		
M143198L04	24	R4147xx161	26	TestPro 3	14
M143198L05	24	R4153xx000	26	TestPro 3 Low Profile	16
M143330L02	21	R4155xx000	26	TestPro 4.2	10
M143330L03	21	R4157xx000	26	TestPro 5	20
M143338L04	24	R4160xx000	26	TestPro 8	23
M143338L05	24	R4161xx000	26		
M163065C00	22	R4168xx000	26		
M163065C03	22				
M163068C00	25	R125703000	26		
M163068C05	25	R125703001	26		
M163195L02	22	R125704000	26		
M163195L03	22	R125704001	26		
M163198L04	25	R125705000	26		
M163198L05	25	R125705001	26		
M163325L02	22	R127801311	15		
M163325L03	22	R127801321	15		
M163328L04	25	R127801331	17		
M163328L05	25	R127822101	15		
M125064C00	11	R127822111	15		
M125064C01	11	R127822121	17		



AEROSPACE



AUTOMOTIVE



DEFENSE



INDUSTRIAL



INSTRUMENTATION



MEDICAL



SPACE



TELECOM

EUROPE

France - RADIALL S.A.

101, Rue Ph. Hoffmann
93116 ROSNY sous BOIS (Paris)
Tel.: +33 1 49 35 35 35 - Fax: +33 1 48 54 63 63
E-Mail: info@radiall.com

Finland - RADIALL SF

P.O. Box 202 - 90101 OULU
Tel.: +358 407 522 412
E-Mail: infofi@radiall.com

Germany - RADIALL GmbH

Carl-Zeiss Str. 10 Postfach 200143
D63307 - RÖDERMARK (Frankfurt)
Tel.: +49 60 74 91 07 0 - Fax: +49 60 74 91 07 70
E-Mail: infode@radiall.com

Italy - RADIALL Elettronica S.R.L.

Via Concordia, 5 - 20090 ASSAGO MILANO
Tel.: +39 02 48 85 121 - Fax: +39 02 48 84 30 18
E-Mail: infoit@radiall.com
Regional office: Roma

Netherlands - RADIALL B.V.

Hogebrinkerweg 15b - 3871 KM HOEVELAKEN
Tel.: +31 33 253 40 09 - Fax: +31 33 253 45 12
E-Mail: infofl@radiall.com

Sweden - RADIALL A.B.

Sjöängsvägen 2 - SE-192 72 SOLLENTUNA (Stockholm)
Tel.: +46 844 434 10 - Fax: +46 875 449 16
E-Mail: infose@radiall.com

U.K. - RADIALL Ltd.

Ground Floor, 6 The Grand Union Office Park,
Packet Boat Lane
UXBRIDGE Middlesex UB8 2GH (London)
Tel.: +44 1895 425 000 - Fax: +44 1895 425 010
E-Mail: infouk@radiall.com

NORTH AMERICA

USA - RADIALL USA, Inc.

6825 West Galveston Street
CHANDLER, Arizona 85226
Tel.: +1 480 682 9400 - Fax: +1 480 682 9403
E-Mail: infousa@radiall.com

ASIA

China - SHANGHAI RADIALL Electronic Co., Ltd.

N° 390 Yong He Road 200072 - SHANGHAI
Tel.: +86 21 66 52 37 88 - Fax: +86 21 66 52 11 77
E-Mail: infosh@radiall.com

Japan - NIHON RADIALL

Shibuya-ku Ebisu 1-5-2, Kougetsu Bldg 405
TOKYO 150-0013
Tel.: +81 3 3440 6241 - Fax: +81 3 3440 6242
E-Mail: infojp@radiall.com

Hong Kong - RADIALL Electronics Ltd.

Flat D, 6/F, Ford Glory Plaza,
37-39 Wing Hong Street
Cheung Sha Wan
KOWLOON HONG KONG
Tel: +852-2959-3833 - Fax: +852-2959-2636
E-Mail: infohk@radiall.com

India - RADIALL India Pvt. Ltd.

25 D, II Phase, Peenya Industrial Area
BANGALORE 560058
Tel.: +91 80 83 95 271 - Fax: +91 80 83 97 228
E-Mail: infoin@radiall.com

ALSO REPRESENTED IN

Australia	Hungary	Poland
Austria	Indonesia	Russia
Belgium	Israel	Singapore
Brazil	Korea	Spain
Czech Republic	Latvia	Switzerland
Denmark	Lithuania	Taiwan
Estonia	Malaysia	Thailand
Greece	Norway	Vietnam
	Philippines	South Africa

For the above countries, please contact the local agent or RADIALL at info@radiall.com



Valued customer:

This pdf file contains interactive hyperlinks for faster access to product data.

Pages such as “Contents” and “Part number index” contain hyperlinks to allow you to navigate to the exact page you are interested in.

In addition, two hyperlinks are included at the bottom of every page to refer you back to the “Contents” and “Part number index” pages to further assist you in your search.

We understand your time is valuable and hope that this new interactive tool will allow you to access Radiall data more efficiently with fewer clicks.

Sincerely

Radiall TestPro team



Компания «ЭлектроПласт» предлагает заключение долгосрочных отношений при поставках импортных электронных компонентов на взаимовыгодных условиях!

Наши преимущества:

- Оперативные поставки широкого спектра электронных компонентов отечественного и импортного производства напрямую от производителей и с крупнейших мировых складов;
- Поставка более 17-ти миллионов наименований электронных компонентов;
- Поставка сложных, дефицитных, либо снятых с производства позиций;
- Оперативные сроки поставки под заказ (от 5 рабочих дней);
- Экспресс доставка в любую точку России;
- Техническая поддержка проекта, помощь в подборе аналогов, поставка прототипов;
- Система менеджмента качества сертифицирована по Международному стандарту ISO 9001;
- Лицензия ФСБ на осуществление работ с использованием сведений, составляющих государственную тайну;
- Поставка специализированных компонентов (Xilinx, Altera, Analog Devices, Intersil, Interpoint, Microsemi, Aeroflex, Peregrine, Syfer, Eurofarad, Texas Instrument, Miteq, Cobham, E2V, MA-COM, Hittite, Mini-Circuits, General Dynamics и др.);

Помимо этого, одним из направлений компании «ЭлектроПласт» является направление «Источники питания». Мы предлагаем Вам помощь Конструкторского отдела:

- Подбор оптимального решения, техническое обоснование при выборе компонента;
- Подбор аналогов;
- Консультации по применению компонента;
- Поставка образцов и прототипов;
- Техническая поддержка проекта;
- Защита от снятия компонента с производства.



Как с нами связаться

Телефон: 8 (812) 309 58 32 (многоканальный)

Факс: 8 (812) 320-02-42

Электронная почта: org@eplast1.ru

Адрес: 198099, г. Санкт-Петербург, ул. Калинина, дом 2, корпус 4, литера А.