



Precision Linear Transducers, Conductive Plastic, up to 450 mm



FEATURES

- Measurement range 25 mm to 450 mm
- High accuracy $\pm 1\%$ down to $\pm 0.025\%$
- Essentially infinite resolution
- Long life
- Sealed on request
- Material categorization: for definitions of compliance please see www.vishay.com/doc?99912



RoHS COMPLIANT

The 34 L is a compact, accurate and adaptable motion transducer for both industrial and military markets.

QUICK REFERENCE DATA

Sensor type	LINEAR, conductive plastic
Output type	Wires
Market appliance	Professional
Dimensions	L x 19 mm dia. (with L = TET + 63 mm)

ELECTRICAL SPECIFICATIONS

Theoretical electrical travel (TET = E) in increments of 25 mm	25 mm 450 mm
Independent linearity (over TET) On request	$\leq \pm 1\%$ - $\leq \pm 0.1\%$ $\leq \pm 0.05\%$ for $E \geq 100$ mm $\leq \pm 0.025\%$ for $E \geq 200$ mm
Actual electrical travel (AET)	See table 1
Ohmic values (R_T)	From 400 Ω /cm to 2 k Ω /cm
Resistance tolerance at 20 °C	$\pm 20\%$
Repeatability	$\leq 0.01\%$
Maximum power rating	0.05 W/cm at 70 °C, 0 W at 125 °C
Wiper current	Recommended: a few μ A - 1 mA max. (continuous)
Load resistance	Minimum $10^3 \times R_T$
Number of tracks	1; on request 2
Insulation resistance	≥ 1000 M Ω , 500 V _{DC}
Dielectric strength	≥ 750 V _{RMS} , 50 Hz

MECHANICAL SPECIFICATIONS

Mechanical travel	TET + 2 mm min.	
Housing	Anodized aluminum	
Operating force On Request	0.35 N typical (standard model)	2.50 N typical (sealed model)
Shaft (free rotation)	Stainless steel	
Termination On request	3 wires PTFE AWG-30 L = 300 mm cable or connector	
Wiper	Precious metal multifinger	
Sealing	IP65 on request	

PERFORMANCE

Operating life	25 million cycles typical/1 Hz/T° = 20 °C \pm 5 °C/80 % TET
Temperature range	-55 °C to +125 °C
Sine vibration on 3 axes	1.5 mm peak to peak or 15 g - 10 Hz - 2000 Hz
Mechanical shocks on 3 axes	50 g - 11 ms - half sine

Note

- Nothing stated herein shall be construed as a guarantee of quality or durability.

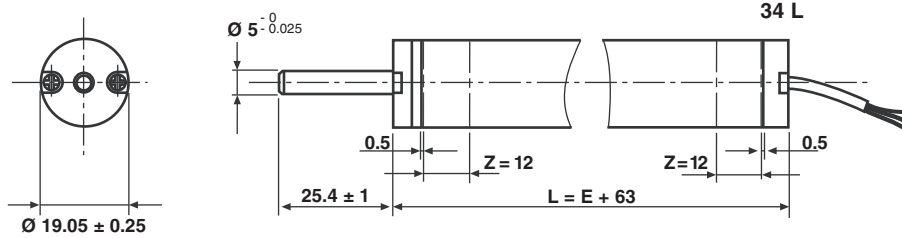
STANDARD MODEL DIMENSIONS in millimeters, general tolerance ± 1 mm

Z = TIGHTENING ZONE

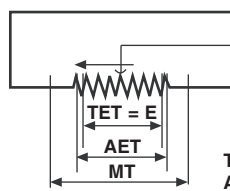
ELECTRICAL CONNECTIONS

TERMINALS	WIRE	CABLE
3 ALIM. (+):	GREEN	BLUE
2 WIPER:	RED	RED
1 ALIM. (-):	YELLOW	WHITE

TET = THEORETICAL ELECTRICAL TRAVEL
 AET = ACTUAL ELECTRICAL TRAVEL
 MT = MECHANICAL TRAVEL

TET = E	AET	TOL.
25 mm to 275 mm	E + 1 mm	± 0.5 mm
300 mm to 450 mm	E + 1 mm	± 0.8 mm

ACCESSORIES ON REQUEST - DIMENSIONS in millimeters, general tolerance ± 3 mm

Clamp for 34L

Vishay Reference: CQ00051

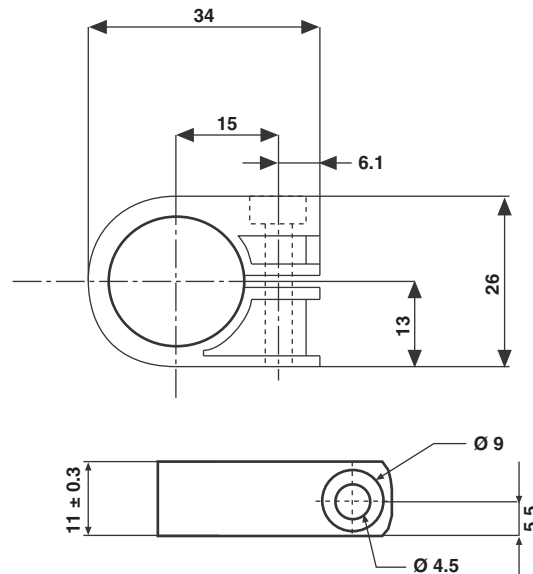

OPTIONS - DIMENSIONS in millimeters, general tolerance ± 1 mm

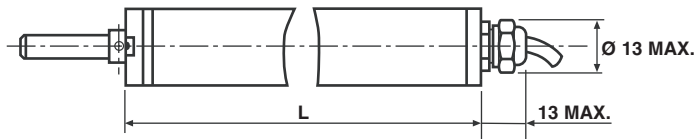
OPTION 1: SEALED (IP65): W03280

MODEL	CODE	L
34 L	W03280	TET + 83.5

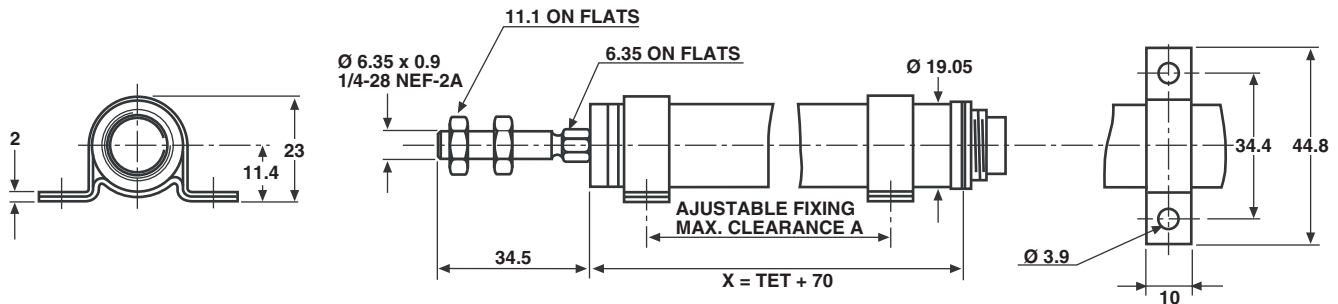
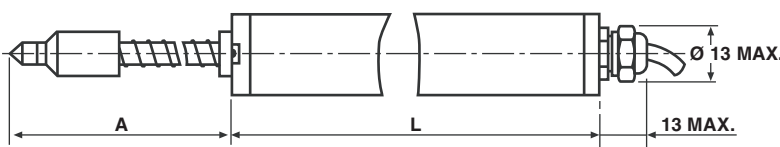
OPTION 2: DELIVERED WITH CLAMPS AND BINDER CONNECTOR 680: W05013

OPTION 3: SPRING LOADED SHAFT; OUTPUT BY SHIELDED CABLE: W01744

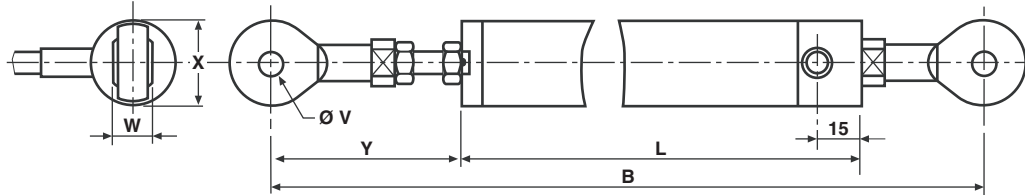
MODEL	CODE	A	L
34 L1	W01744	61.4	TET + 119.5
34 L2	W01744	93.6	
34 L3	W01744	125.8	
34 L4	W01744	158	

OPTION 4: DOUBLE BALL JOINT: W03263

MODEL CODE	B	L	Ø V	W	X	Y	TET
34 L W03263 L1 to L5	TET + 151.6	TET + 82.8	5	8	18	42 ± 2	25 to 125
L6 to L10	TET + 173.6	TET + 104.8	5	8	18	42 ± 2	150 to 250
L11 to L12	TET + 230	TET + 161.2	5	8	18	42 ± 2	275 to 300

ORDERING INFORMATION/DESCRIPTION

REC	34	L	3	D	103	W...	e.
SERIES	MODEL	NUMBER OF TRACKS	THEORETICAL ELECTRICAL TRAVEL	LINEARITY	OHMIC VALUE	MODIFICATIONS	LEAD FINISH
		L = 1 track LL = 2 tracks	Times 25 mm	A: ± 1 % D: ± 0.1 % E: ± 0.05 % F: ± 0.025 %	First 2 digits are significant numbers 3 rd digit indicates number of zeros	Special feature code number	

SAP PART NUMBERING GUIDELINES

RE	34 L	3	D	103	W....
SERIES	MODEL	TET	LINEARITY	OHMIC VALUE	SPECIAL FEATURES



Disclaimer

ALL PRODUCT, PRODUCT SPECIFICATIONS AND DATA ARE SUBJECT TO CHANGE WITHOUT NOTICE TO IMPROVE RELIABILITY, FUNCTION OR DESIGN OR OTHERWISE.

Vishay Intertechnology, Inc., its affiliates, agents, and employees, and all persons acting on its or their behalf (collectively, "Vishay"), disclaim any and all liability for any errors, inaccuracies or incompleteness contained in any datasheet or in any other disclosure relating to any product.

Vishay makes no warranty, representation or guarantee regarding the suitability of the products for any particular purpose or the continuing production of any product. To the maximum extent permitted by applicable law, Vishay disclaims (i) any and all liability arising out of the application or use of any product, (ii) any and all liability, including without limitation special, consequential or incidental damages, and (iii) any and all implied warranties, including warranties of fitness for particular purpose, non-infringement and merchantability.

Statements regarding the suitability of products for certain types of applications are based on Vishay's knowledge of typical requirements that are often placed on Vishay products in generic applications. Such statements are not binding statements about the suitability of products for a particular application. It is the customer's responsibility to validate that a particular product with the properties described in the product specification is suitable for use in a particular application. Parameters provided in datasheets and/or specifications may vary in different applications and performance may vary over time. All operating parameters, including typical parameters, must be validated for each customer application by the customer's technical experts. Product specifications do not expand or otherwise modify Vishay's terms and conditions of purchase, including but not limited to the warranty expressed therein.

Except as expressly indicated in writing, Vishay products are not designed for use in medical, life-saving, or life-sustaining applications or for any other application in which the failure of the Vishay product could result in personal injury or death. Customers using or selling Vishay products not expressly indicated for use in such applications do so at their own risk. Please contact authorized Vishay personnel to obtain written terms and conditions regarding products designed for such applications.

No license, express or implied, by estoppel or otherwise, to any intellectual property rights is granted by this document or by any conduct of Vishay. Product names and markings noted herein may be trademarks of their respective owners.

Material Category Policy

Vishay Intertechnology, Inc. hereby certifies that all its products that are identified as RoHS-Compliant fulfill the definitions and restrictions defined under Directive 2011/65/EU of The European Parliament and of the Council of June 8, 2011 on the restriction of the use of certain hazardous substances in electrical and electronic equipment (EEE) - recast, unless otherwise specified as non-compliant.

Please note that some Vishay documentation may still make reference to RoHS Directive 2002/95/EC. We confirm that all the products identified as being compliant to Directive 2002/95/EC conform to Directive 2011/65/EU.

Vishay Intertechnology, Inc. hereby certifies that all its products that are identified as Halogen-Free follow Halogen-Free requirements as per JEDEC JS709A standards. Please note that some Vishay documentation may still make reference to the IEC 61249-2-21 definition. We confirm that all the products identified as being compliant to IEC 61249-2-21 conform to JEDEC JS709A standards.



Компания «ЭлектроПласт» предлагает заключение долгосрочных отношений при поставках импортных электронных компонентов на взаимовыгодных условиях!

Наши преимущества:

- Оперативные поставки широкого спектра электронных компонентов отечественного и импортного производства напрямую от производителей и с крупнейших мировых складов;
- Поставка более 17-ти миллионов наименований электронных компонентов;
- Поставка сложных, дефицитных, либо снятых с производства позиций;
- Оперативные сроки поставки под заказ (от 5 рабочих дней);
- Экспресс доставка в любую точку России;
- Техническая поддержка проекта, помощь в подборе аналогов, поставка прототипов;
- Система менеджмента качества сертифицирована по Международному стандарту ISO 9001;
- Лицензия ФСБ на осуществление работ с использованием сведений, составляющих государственную тайну;
- Поставка специализированных компонентов (Xilinx, Altera, Analog Devices, Intersil, Interpoint, Microsemi, Aeroflex, Peregrine, Syfer, Eurofarad, Texas Instrument, Miteq, Cobham, E2V, MA-COM, Hittite, Mini-Circuits, General Dynamics и др.);

Помимо этого, одним из направлений компании «ЭлектроПласт» является направление «Источники питания». Мы предлагаем Вам помощь Конструкторского отдела:

- Подбор оптимального решения, техническое обоснование при выборе компонента;
- Подбор аналогов;
- Консультации по применению компонента;
- Поставка образцов и прототипов;
- Техническая поддержка проекта;
- Защита от снятия компонента с производства.



Как с нами связаться

Телефон: 8 (812) 309 58 32 (многоканальный)

Факс: 8 (812) 320-02-42

Электронная почта: org@eplast1.ru

Адрес: 198099, г. Санкт-Петербург, ул. Калинина, дом 2, корпус 4, литера А.