



**Reduce disruptive EMI and RFI with Woodhead® MAX-LOC® Plus Shielded Cord-Grip Assemblies, featuring a simplified installation design ideal for high-frequency switched-mode power supply (SMPS) applications**

Woodhead® MAX-LOC® Plus Shielded Cord-Grip Assemblies allow OEM's and end-user's to connect high-power electrical cables directly to an application via an exterior mounting enclosure, simplifying the installation process for high-volume, cost-sensitive programs. The robust assemblies provide excellent EMI and RFI shielding plus sealing protection (liquids and dust). MAX-LOC® Plus Shielded Cord-Grip Assemblies bring multiple features found across numerous products into a single-product solution. This unique design results in cost and labor savings over conventional industry-standard products.

**Features and Benefits**

Nickel-plated aluminum housing and shielding ring	Provide electro magnetic interference (EM) and radio frequency interference (RFI) protection
Unique grip-body internal cut-away design	Ensures a clear pass-through of pre-assembled harnesses and pre-crimped lugs through center and offset lugs. Provides simple assembly and field serviceability
Tapered shielding ring (as opposed to competitor's finger contacts)	Provides a robust, reliable connection. Ensures low contact resistance and cable grounding
Internal wedge-shaped grommet	Provides liquid and dust sealing and cable retention to withstand 50 pounds (222.4N) pull force versus two installers) directly to the OEM panel, enclosure or vehicle body. Ensures stable connection in rugged applications
Two external mounting holes	Simplify the installation process via a single-side connection (single person versus two installers) directly to the OEM panel, enclosure or vehicle body. Ensures stable connection in rugged applications
Aluminum die-cast, nickel-plated threaded assembly	Strong, light-weight design for ease of use. Reduces galling (wear and transfer of material between the assembly and panel)
Compression nut	Provides cable retention to withstand 222.4N (50 lbs.) pull force
Sealed O-ring, IP67 and IP69K rated	Seals out moisture and dust contamination. Meets SAE industry standards
Grip assembly accommodates 1 AWG, 1/0, 2/0 shielded cables with an expanded range to follow	Provides design flexibility and installed cost savings. Meets harsh-environment application requirements

**Woodhead®  
MAX-LOC® Plus  
Shielded Cord-Grip  
Assemblies**

**130199** MAX-LOC®  
Plus Cord-Grip  
Assemblies



MAX-LOC® Plus Shielded Cord-Grip Assembly with terminated VersaKrimp™ Compression Lug



# Woodhead® MAX-LOC® Plus Shielded Cord-Grip Assemblies

## Additional Product Features

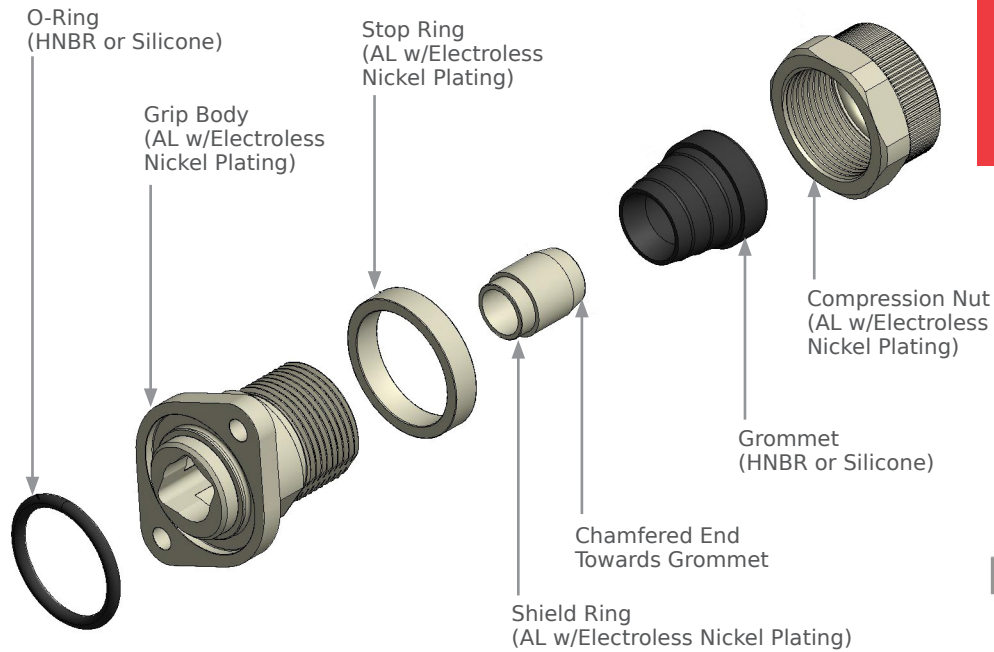

Exploded View of MAX-LOC® Plus Shielded Cord-Grip Assembly

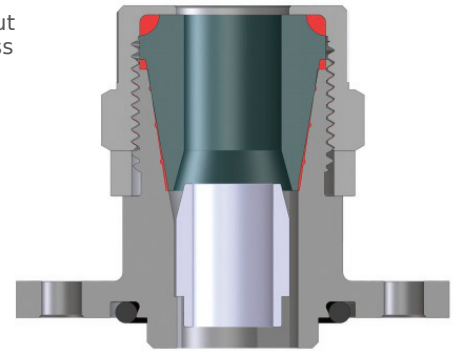

Cross View of MAX-LOC® Shielded Cord Grip Assembly

## Applications

- Industrial (Automation)
  - Power-inverter, motor, drive installations
  - Factory automation
  - Process control
- Aerospace and Defense
  - Hybrid electric vehicles
  - Electrical-vehicle-drive systems
- Commercial Vehicle
  - Hybrid electric vehicles
  - Construction/agricultural
  - Buses
  - Mining
- Alternative Energy
  - Wind mills
  - Solar
  - Scientific
  - Bio-reactors
- Telecommunications/Networking
  - HVAC variable-speed motors

Component Assembly View with Shielded Cable

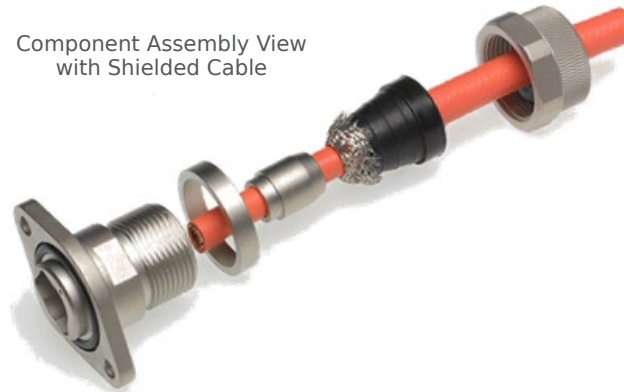

Pressure Washer



## Specifications

### Reference Information

Packaging: Box  
RoHS: Yes  
Halogen Free: Yes

### Mechanical

Cable Retention:  
50 pounds (222.4N) cable pull  
withstand for 30 seconds

### Electrical

EMI/RFI Shielding: 360°  
Die-Electric Withstand: 2400V AC for  
1 minute

### Environmental

Immersion: IP67 and IP68 rated  
Power Wash (Duration of 5 Minutes):  
12,000kPaG (~1740psig), 13 l/min  
(~ 3.4 gal/min).  
Operating Temperature:  
HNBR — -40 to +150°C  
Silicone — -60 to +200°C  
UV resistant  
Meets UL 94 VO flammability rating

### Physical

Housing: Electroless nickel-plated  
aluminum die-cast  
Nut: Electroless nickel-plated  
aluminum die-cast  
Shield Ring: Electroless nickel-plated  
aluminum die-cast  
Stop Ring: Electroless nickel-plated  
aluminum die-cast  
Grommet: HNBR or Silicone  
O-Ring: HNBR or Silicone

## Woodhead® MAX-LOC® Plus Shielded Cord-Grip Assemblies

## Ordering Information

Order No.	Cable Gauge (AWG)	Grommet/O-ring Material
130199-0030	1	HNBR
130199-0020	1/0	
130199-0025	2/0	
130199-0080	3/0	
130199-0230	1	Silicone
130199-0220	1/0	
130199-0225	2/0	
130199-0280	3/0	

[www.molex.com/product/maxlocplus.html](http://www.molex.com/product/maxlocplus.html)



Компания «ЭлектроПласт» предлагает заключение долгосрочных отношений при поставках импортных электронных компонентов на взаимовыгодных условиях!

Наши преимущества:

- Оперативные поставки широкого спектра электронных компонентов отечественного и импортного производства напрямую от производителей и с крупнейших мировых складов;
- Поставка более 17-ти миллионов наименований электронных компонентов;
- Поставка сложных, дефицитных, либо снятых с производства позиций;
- Оперативные сроки поставки под заказ (от 5 рабочих дней);
- Экспресс доставка в любую точку России;
- Техническая поддержка проекта, помощь в подборе аналогов, поставка прототипов;
- Система менеджмента качества сертифицирована по Международному стандарту ISO 9001;
- Лицензия ФСБ на осуществление работ с использованием сведений, составляющих государственную тайну;
- Поставка специализированных компонентов (Xilinx, Altera, Analog Devices, Intersil, Interpoint, Microsemi, Aeroflex, Peregrine, Syfer, Eurofarad, Texas Instrument, Miteq, Cobham, E2V, MA-COM, Hittite, Mini-Circuits, General Dynamics и др.);

Помимо этого, одним из направлений компании «ЭлектроПласт» является направление «Источники питания». Мы предлагаем Вам помощь Конструкторского отдела:

- Подбор оптимального решения, техническое обоснование при выборе компонента;
- Подбор аналогов;
- Консультации по применению компонента;
- Поставка образцов и прототипов;
- Техническая поддержка проекта;
- Защита от снятия компонента с производства.



#### Как с нами связаться

**Телефон:** 8 (812) 309 58 32 (многоканальный)

**Факс:** 8 (812) 320-02-42

**Электронная почта:** [org@eplast1.ru](mailto:org@eplast1.ru)

**Адрес:** 198099, г. Санкт-Петербург, ул. Калинина, дом 2, корпус 4, литера А.