

GENERAL DESCRIPTION

The XRP6658 is a synchronous current mode PWM step down (buck) converter capable of delivering up to 1Amp of current and optimized for portable battery-operated applications.

Based on a current-mode 1.5MHz constant frequency PWM control scheme, the XRP6658 reduces the overall component count and solution footprint. It provides low output voltage ripple and excellent line and load regulation. It also implements a PFM mode to improve light load efficiency as well as a 100% duty cycle LDO mode. Output voltage is adjustable to as low as 0.6V with a better than 3% accuracy while a low quiescent current supports the most stringent battery operating conditions.

Built-in over temperature and under voltage lock-out protections insure safe operations under abnormal operating conditions.

The XRP6658 is offered in a RoHS compliant, "green"/halogen free 5-pin SOT23 package.

EVALUATION BOARD MANUAL



FEATURES

- **Guaranteed 1A Output Current**
 - Input Voltage: 2.5V to 5.5V
- **1.5MHz PWM Current Mode Control**
 - PFM Mode Operations at Light Load
 - 100% Duty Cycle LDO Mode Operations
 - Achieves 97% Efficiency
- **Adjustable Output Voltage Range**
 - As Low as 0.6V with $\pm 3\%$ Accuracy
- **Internal Compensation Network**
- **Over Temperature & UVLO Protection**

EVALUATION BOARD SCHEMATICS

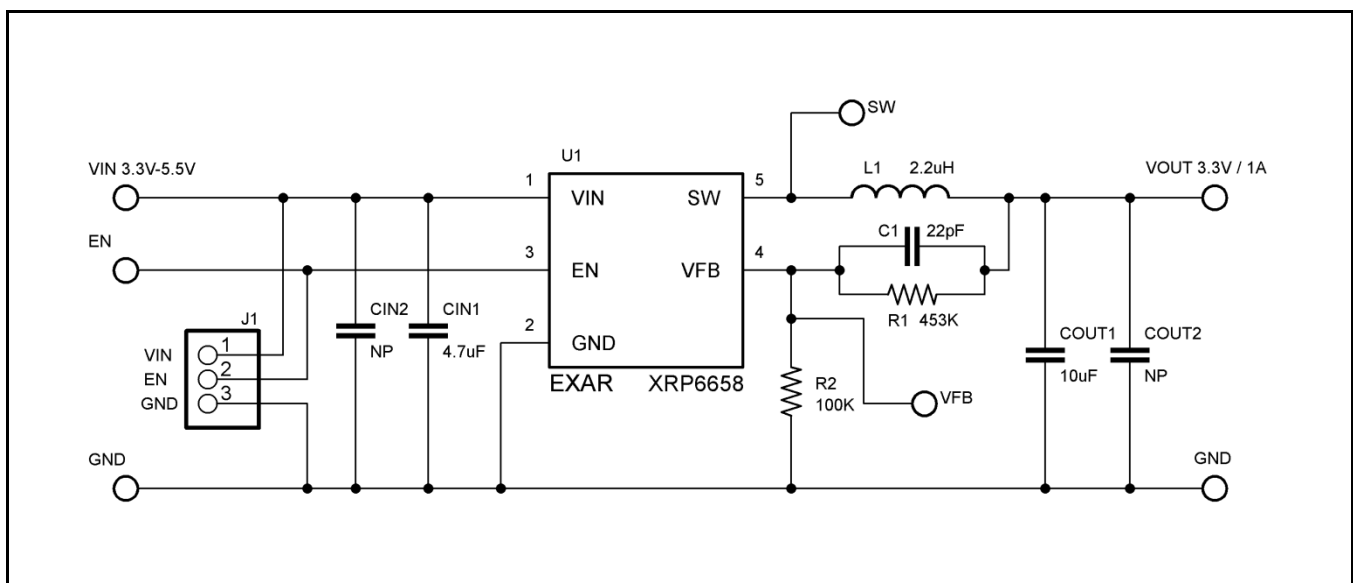

Fig. 1: XRP6658EVB Evaluation Board Schematics

PIN ASSIGNMENT

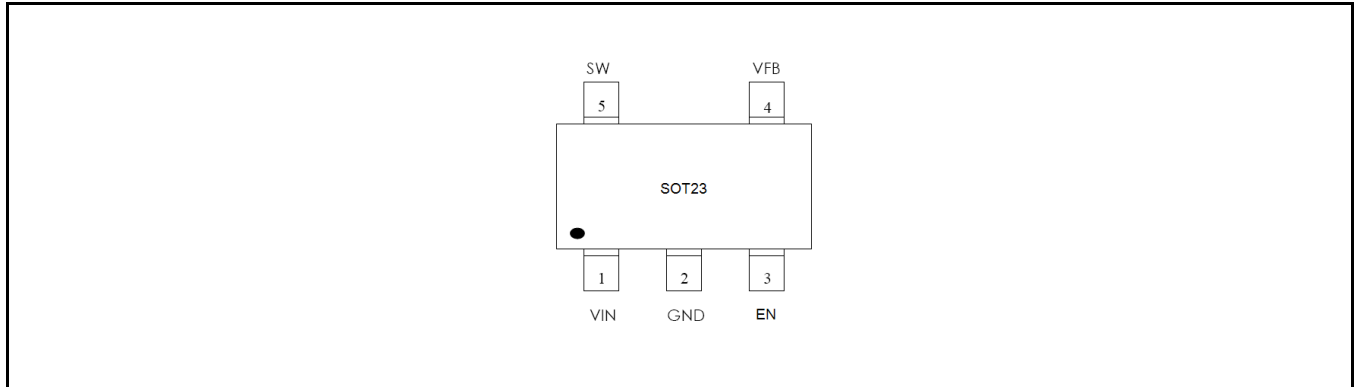

Fig. 2: XRP6658 Pin Assignment

PIN DESCRIPTION

Name	Pin Number	Description
VIN	1	Power Input Pin. Must be closely decoupled to GND pin with a 4.7µF or greater ceramic capacitor.
GND	2	Ground Signal
EN	3	Enable Pin. Minimum 1.2V to enable the device. Maximum 0.4V to shutdown the device.
VFB	4	Feedback Pin. Receives the feedback voltage from an external resistive divider across the output.
SW	5	Switch Pin. Must be connected to Inductor. This pin connects to the drains of the internal main and synchronous power MOSFET switches.

ORDERING INFORMATION

Refer to XRP6658's datasheet and/or www.exar.com for exact and up to date ordering information.

**USING THE EVALUATION BOARD****INITIAL SETUP**

Set the input supply to a voltage between 2.5V to 5.5V and connect it to VIN and GND connectors on the left side of the evaluation board. Connect the load to the VOUT and GND connectors on the right hand side of the board. Check to make sure that jumper J1 is set to VIN. The board will power-up and regulate to the desired output voltage VOUT

set by the feedback resistors. The board will operate with a load current I_{OUT} of up to 1A and provide efficiency equal to figures 4 and 5 of XRP6658 datasheet.

JUMPER J1 FUNCTION

Jumper J1 can be used to either short EN pin to VIN or to GND. The Board is supplied from EXAR with the jumper set to connect EN to VIN.

EVALUATION BOARD SCHEMATICS

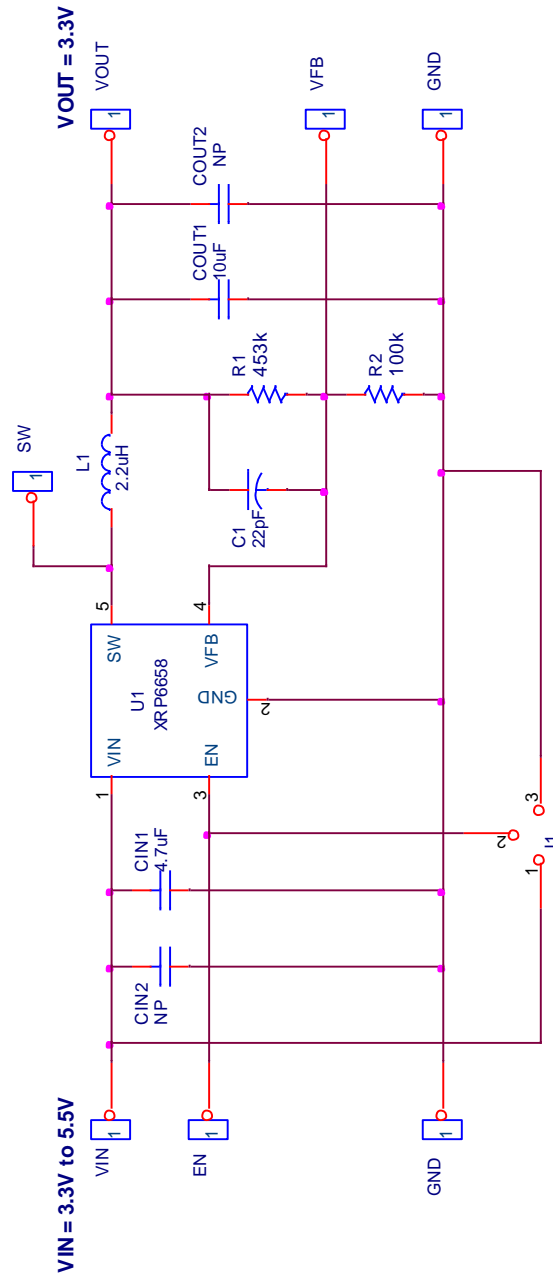



BILL OF MATERIAL

Ref.	Qty	Manufacturer	Part Number	Size	Component
EVAL BD	1	Exar Corp	146-6685-02		XRP6658 Evaluation Board
U1	1	Exar Corp	XRP6658	SOT 23-5	Synchronous Step-Down Regulator
CIN1	1	Murata	GRM21BR71C475KA73L	0805	Ceramic 4.7µF, 16V, X7R
CIN2	1				Not populated
COU1	1	Murata	GRM21BR71A106KE51L	0805	Ceramic 10uF, 10V, X7R
COU2	1				Not populated
C1	1	Murata	GRM1885C1H220JA01D	0603	Ceramic 22pF, 50V, C0G
L1	1	Würth Elektronik	7440430022	4.8mm x 4.8mm x 2.8mm	Inductor 2.2uH, 2.5A, 23mΩ
R1	1	Vishay	CRCW0603453KFKTA	0603	453KΩ Resistor, 0.1W, 1%
R2	1	Vishay	CRCW0603100KFKTA	0603	100KΩ Resistor, 0.1W, 1%
J1	1	Würth Elektronik	61303611121	0.64mm SQ x 6mm	3 Pin Header, 2.54mm pitch
J1 (Jumper)	1	Würth Elektronik	609002115121	0.1"	Jumper short
Test Point VIN, VOUT, EN, SW, GND, VFB	7	Mill-Max	0300-115-01-4727100	0.042" diameter	Test Point Post

EVALUATION BOARD LAYOUT

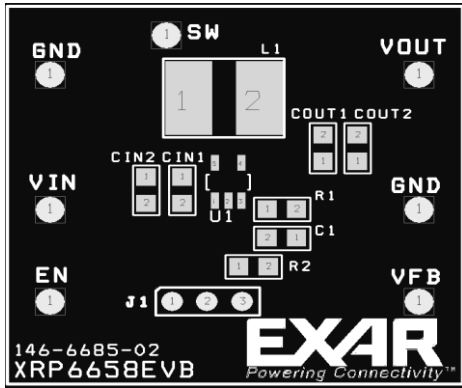

Fig. 3: Component Placement – Top Side

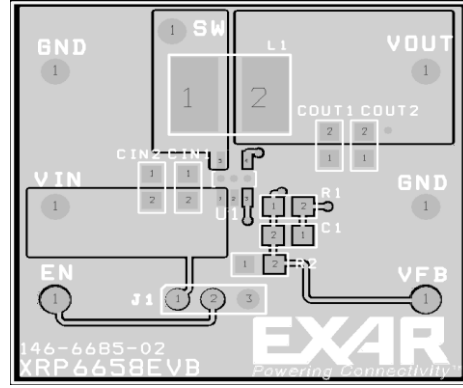

Fig. 4: Component Placement 2 – Top Side

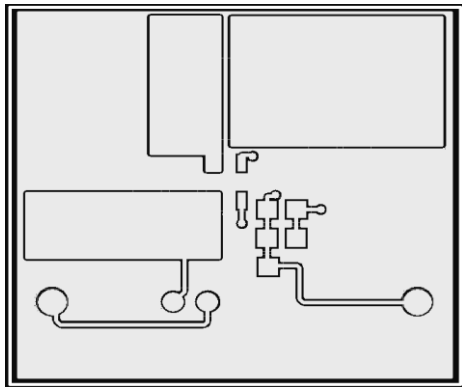

Fig. 5: Layout – Top Side

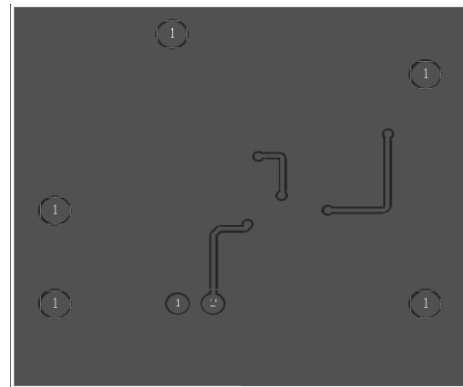

Fig. 6: Layout – Bottom Side



REVISION HISTORY

Revision	Date	Description
1.0.0	09/16/2010	Initial release of document
2.0.0	10/06/2010	Updated evaluation board schematics and lay out.
2.1.0	02/07/2012	Updated bill of material and schematics

FOR FURTHER ASSISTANCE

Email: customersupport@exar.com
Exar Technical Documentation: <http://www.exar.com/TechDoc/default.aspx?>

EXAR CORPORATION

HEADQUARTERS AND SALES OFFICES

48720 Kato Road
Fremont, CA 94538 – USA
Tel.: +1 (510) 668-7000
Fax: +1 (510) 668-7030
www.exar.com



NOTICE

EXAR Corporation reserves the right to make changes to the products contained in this publication in order to improve design, performance or reliability. EXAR Corporation assumes no responsibility for the use of any circuits described herein, conveys no license under any patent or other right, and makes no representation that the circuits are free of patent infringement. Charts and schedules contained here in are only for illustration purposes and may vary depending upon a user's specific application. While the information in this publication has been carefully checked; no responsibility, however, is assumed for inaccuracies.

EXAR Corporation does not recommend the use of any of its products in life support applications where the failure or malfunction of the product can reasonably be expected to cause failure of the life support system or to significantly affect its safety or effectiveness. Products are not authorized for use in such applications unless EXAR Corporation receives, in writing, assurances to its satisfaction that: (a) the risk of injury or damage has been minimized; (b) the user assumes all such risks; (c) potential liability of EXAR Corporation is adequately protected under the circumstances.

Reproduction, in part or whole, without the prior written consent of EXAR Corporation is prohibited.



Компания «ЭлектроПласт» предлагает заключение долгосрочных отношений при поставках импортных электронных компонентов на взаимовыгодных условиях!

Наши преимущества:

- Оперативные поставки широкого спектра электронных компонентов отечественного и импортного производства напрямую от производителей и с крупнейших мировых складов;
- Поставка более 17-ти миллионов наименований электронных компонентов;
- Поставка сложных, дефицитных, либо снятых с производства позиций;
- Оперативные сроки поставки под заказ (от 5 рабочих дней);
- Экспресс доставка в любую точку России;
- Техническая поддержка проекта, помощь в подборе аналогов, поставка прототипов;
- Система менеджмента качества сертифицирована по Международному стандарту ISO 9001;
- Лицензия ФСБ на осуществление работ с использованием сведений, составляющих государственную тайну;
- Поставка специализированных компонентов (Xilinx, Altera, Analog Devices, Intersil, Interpoint, Microsemi, Aeroflex, Peregrine, Syfer, Eurofarad, Texas Instrument, Miteq, Cobham, E2V, MA-COM, Hittite, Mini-Circuits, General Dynamics и др.);

Помимо этого, одним из направлений компании «ЭлектроПласт» является направление «Источники питания». Мы предлагаем Вам помощь Конструкторского отдела:

- Подбор оптимального решения, техническое обоснование при выборе компонента;
- Подбор аналогов;
- Консультации по применению компонента;
- Поставка образцов и прототипов;
- Техническая поддержка проекта;
- Защита от снятия компонента с производства.



Как с нами связаться

Телефон: 8 (812) 309 58 32 (многоканальный)

Факс: 8 (812) 320-02-42

Электронная почта: org@eplast1.ru

Адрес: 198099, г. Санкт-Петербург, ул. Калинина, дом 2, корпус 4, литера А.