

DSP1S Series

Single Output DC-DC Converters

The DSP1 Series is specifically designed to convert a nominal 5 Volt input into an isolated output voltage.

The semi-regulated output voltages were designed to allow analog circuits and three terminal regulators to operate within their most efficient input voltage range.

This series achieves high power densities through the use of 350 kHz fixed-frequency switching converters.

Key Features & Benefits

- RoHS lead solder exemption compliant
- Up to 1 Watt unregulated output power
- Single-In-Line package
- Four-terminal operation
- Efficiencies to 75%
- Output Voltages: 5V, 7V, 12V, 14V, 15V, 17V
- 700 V isolation
- -40 °C to +85 °C operation



1. MODEL SELECTION

MODEL	INPUT RANGE [VDC]			OUTPUT	
	MIN	MAX	[VDC]	[mA]	POWER [W]
DSP1N5S5	4.5	5.5	5	150	0.75
DSP1N5S7	4.5	5.5	7	140	1
DSP1N5S12	4.5	5.5	12	80	1
DSP1N5S14	4.5	5.5	14	70	1
DSP1N5S15	4.5	5.5	15	65	1
DSP1N5S17	4.5	5.5	17	60	1

2. GENERAL SPECIFICATIONS¹

PARAMETER	CONDITIONS / DESCRIPTION	MIN	TYP	MAX	UNITS
<i>Isolation</i>					
Isolation Voltage	Input to Output 10 μ A	700			VDC
Capacitance	Input to Output		25		pF
<i>Environmental</i>					
Case Operating Range (T _c) ²		-40		85	°C
Storage Range		-55		105	°C
Thermal Impedance ³			58		°C / Watt
<i>General</i>					
MTBF	Calculated		700,000		hrs
Weight			0.1/28		oz/g
Case Material					Non Conductive Plastic

NOTES

- ¹ All parameters measured at T_c = 25 °C, nominal input voltage and full rated load unless otherwise noted.
- ² Derate output power linearly to 0.6 watts from 70 °C to 85 °C.
- ³ The case Thermal Impedance is specified as the case temperature rise over ambient per package dissipated.

3. INPUT SPECIFICATIONS¹

PARAMETER	CONDITIONS / DESCRIPTION	MIN	TYP	MAX	UNITS	
Voltage Range		4.5		5.5	VDC	
Reflected Ripple ²	DSP1N5S7 / DSP1N5S12 / DSP1N5S14 / DSP1N5S15 / DSP1N5S17		50 65		mApp	
Input Current	Full Load		DSP1N5S5 221 DSP1N5S7 280 DSP1N5S12 263 DSP1N5S14 268 DSP1N5S15 267 DSP1N5S17 279		mA	
			20		mA	
				68		
				70		%
			DSP1N5S12 / DSP1N5S14 / DSP1N5S15 / DSP1N5S17		73	
Switching Frequency			350		kHz	

4. OUTPUT SPECIFICATIONS¹

PARAMETER	CONDITIONS / DESCRIPTION	MIN	TYP	MAX	UNITS
Output Voltage	DSP1N5S5		5		VDC
	DSP1N5S7		7		
	DSP1N5S12		12		
	DSP1N5S14		14		
	DSP1N5S15		15		
	DSP1N5S17		17		
Output Voltage Accuracy ³	DSP1N5S5	4.75	5.00	5.25	VDC
	DSP1N5S7	6.65	7.00	7.35	
	DSP1N5S12	11.40	12.00	12.60	
	DSP1N5S14	13.30	14.00	14.70	
	DSP1N5S15	14.25	15.00	15.75	
	DSP1N5S17	16.15	17.00	17.85	
Output Voltage, No Load	DSP1N5S5		7		VDC
	DSP1N5S7		10		
	DSP1N5S12		16		
	DSP1N5S14		19		
	DSP1N5S15		21		
	DSP1N5S17		24		
Rated Load Range	DSP1N5S5	0		150	mA
	DSP1N5S7			140	
	DSP1N5S12			80	
	DSP1N5S14			70	
	DSP1N5S15			65	
	DSP1N5S17			60	
Load Regulation ⁴	75% - 20% Load		+8		%
	75% - 100% Load		-5		
Line Regulation ⁵			1.6		%
Noise, Peak – Peak ²			70		mVpp
Temperature Coefficient			400		ppm/°C
Short Circuit Protection to Common ⁶			Momentary		

NOTES

- ¹ All parameters measured at Tc= 25 °C, nominal input voltage and full rated load unless otherwise noted.
- ² Noise measurement bandwidth is 20 MHz. Input Reflected Ripple and output noise are measured with an external 10µF/25V tantalum capacitor connected across the input and output pins.
- ³ Output Voltage Accuracy measured at 75% of maximum Rated Load.
- ⁴ Load Regulations measured relative to 75% of maximum Rated Load Current.
- ⁵ Line Regulation is for a 1.0% change in input Voltage.
- ⁶ Use input fuse for protection. See Applying the input.

5. DSP1 SERIES APPLICATION NOTES

EXTERNAL CAPACITANCE REQUIREMENTS

Output filtering is required for operation. A minimum of 10 F is specified for optimal performance. Output capacitance may be increased for additional filtering, not to exceed 400 F. To meet the reflected ripple requirements of the converter, an input impedance of less than 0.5 Ohms from DC to 350 kHz is required. If a capacitive input source is farther than 2” from the converter, it is recommended to use a 10 F, 25 V solid tantalum capacitor.

REGULATION

This converter uses a semi-regulated design. The output will vary as the load is changed, with output decreasing with increasing load. See Output Voltage vs. Output Load curves. Additionally, output voltage will change in proportion to a change in input voltage. The typical output voltage will change 1.2% for each 1% change in input voltage.

NEGATIVE OUTPUTS

A negative output voltage may be obtained by connecting the +OUT to circuit ground and connecting -OUT as the negative output.



Asia-Pacific
+86 755 298 85888

Europe, Middle East
+353 61 225 977

North America
+1 408 785 5200

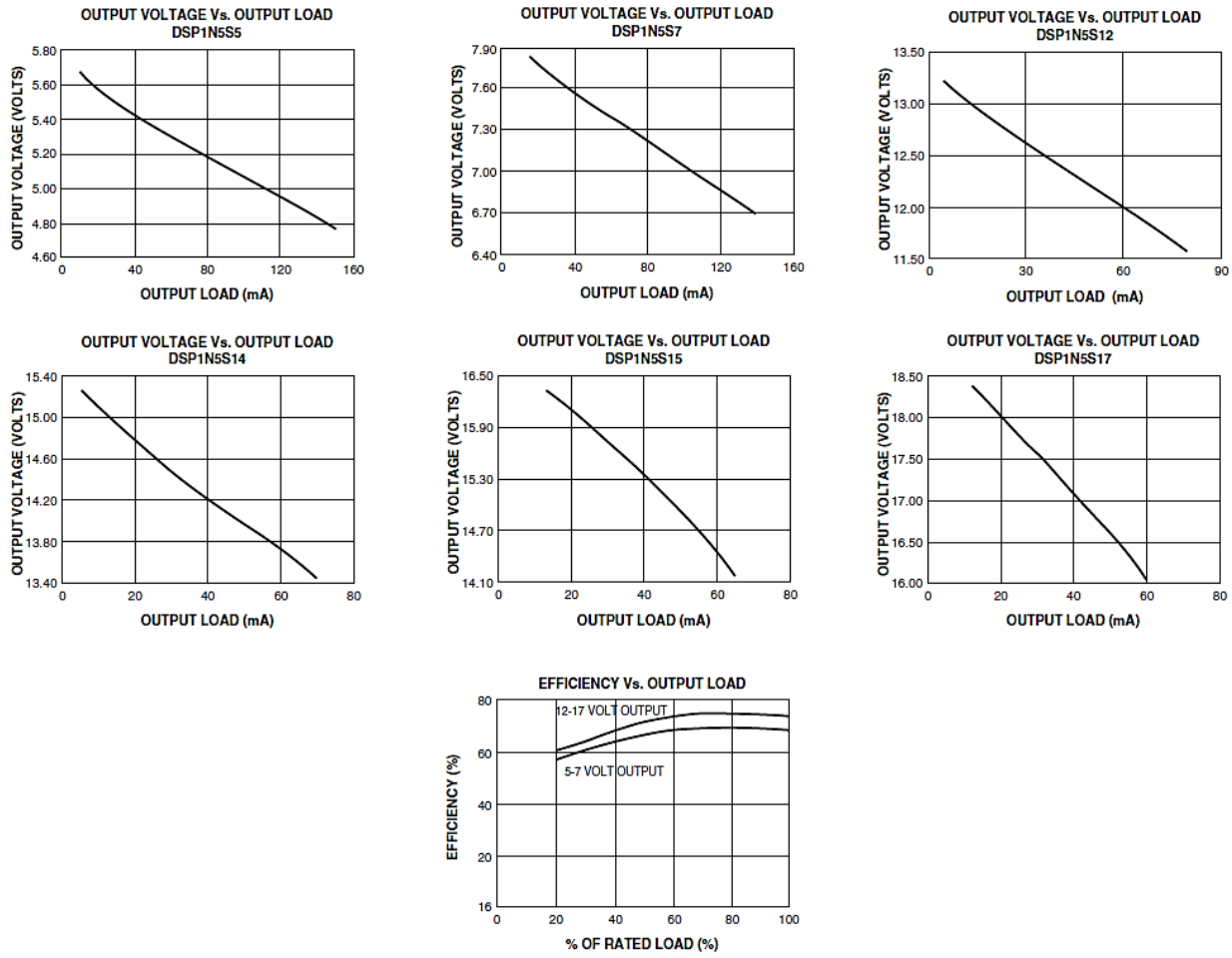

Figure 1. Typical Performance ($T_c = 25^\circ\text{C}$)

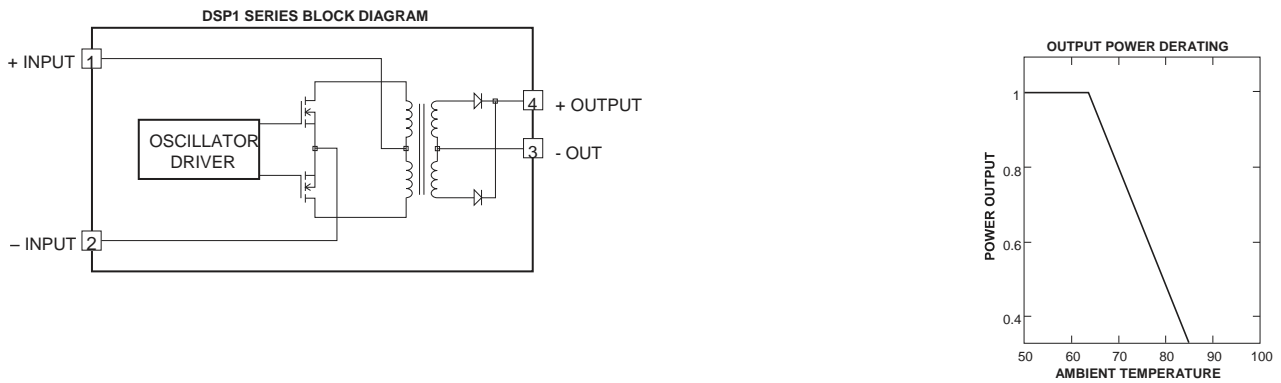
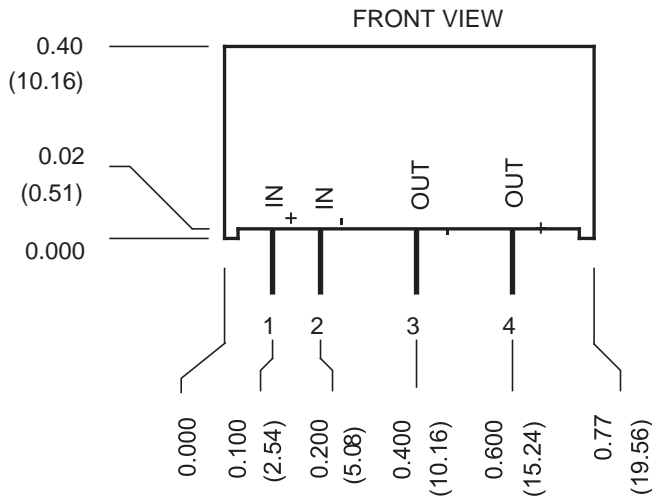

Figure 2. Block Diagram



PIN	FUNCTION
1	+INPUT
2	-INPUT
3	- OUT
4	+OUT

Mechanical tolerances unless otherwise noted:

X.XX dimensions: ± 0.020 inches
 X.XXX dimensions: ± 0.010 inches

* This dimension to decrease to 0.24 ± 0.01 " (6.09 ± 0.25) in 1998

** This dimension to decrease to 0.035 ± 0.015 " (0.89 ± 0.38) in 1998

Figure 3. Mechanical Dimensions

For more information on these products consult: tech.support@psbel.com

NUCLEAR AND MEDICAL APPLICATIONS - Products are not designed or intended for use as critical components in life support systems, equipment used in hazardous environments, or nuclear control systems.

TECHNICAL REVISIONS - The appearance of products, including safety agency certifications pictured on labels, may change depending on the date manufactured. Specifications are subject to change without notice.



Asia-Pacific
+86 755 298 85888

Europe, Middle East
+353 61 225 977

North America
+1 408 785 5200



Компания «ЭлектроПласт» предлагает заключение долгосрочных отношений при поставках импортных электронных компонентов на взаимовыгодных условиях!

Наши преимущества:

- Оперативные поставки широкого спектра электронных компонентов отечественного и импортного производства напрямую от производителей и с крупнейших мировых складов;
- Поставка более 17-ти миллионов наименований электронных компонентов;
- Поставка сложных, дефицитных, либо снятых с производства позиций;
- Оперативные сроки поставки под заказ (от 5 рабочих дней);
- Экспресс доставка в любую точку России;
- Техническая поддержка проекта, помощь в подборе аналогов, поставка прототипов;
- Система менеджмента качества сертифицирована по Международному стандарту ISO 9001;
- Лицензия ФСБ на осуществление работ с использованием сведений, составляющих государственную тайну;
- Поставка специализированных компонентов (Xilinx, Altera, Analog Devices, Intersil, Interpoint, Microsemi, Aeroflex, Peregrine, Syfer, Eurofarad, Texas Instrument, Miteq, Cobham, E2V, MA-COM, Hittite, Mini-Circuits, General Dynamics и др.);

Помимо этого, одним из направлений компании «ЭлектроПласт» является направление «Источники питания». Мы предлагаем Вам помощь Конструкторского отдела:

- Подбор оптимального решения, техническое обоснование при выборе компонента;
- Подбор аналогов;
- Консультации по применению компонента;
- Поставка образцов и прототипов;
- Техническая поддержка проекта;
- Защита от снятия компонента с производства.



Как с нами связаться

Телефон: 8 (812) 309 58 32 (многоканальный)

Факс: 8 (812) 320-02-42

Электронная почта: org@eplast1.ru

Адрес: 198099, г. Санкт-Петербург, ул. Калинина, дом 2, корпус 4, литера А.