

LOC		DIST		REVISIONS			
P	LTN	DESCRIPTION	DATE	OWN	APVD		
G		ECO-15-006810	22JAN2016	LL	SH		
H		ECO-16-010145	11JUL2016	LL	SH		
J		ECO-16-011047	25JUL2016	LL	SH		
K		ECO-17-011372	04AUG2017	LL	SH		

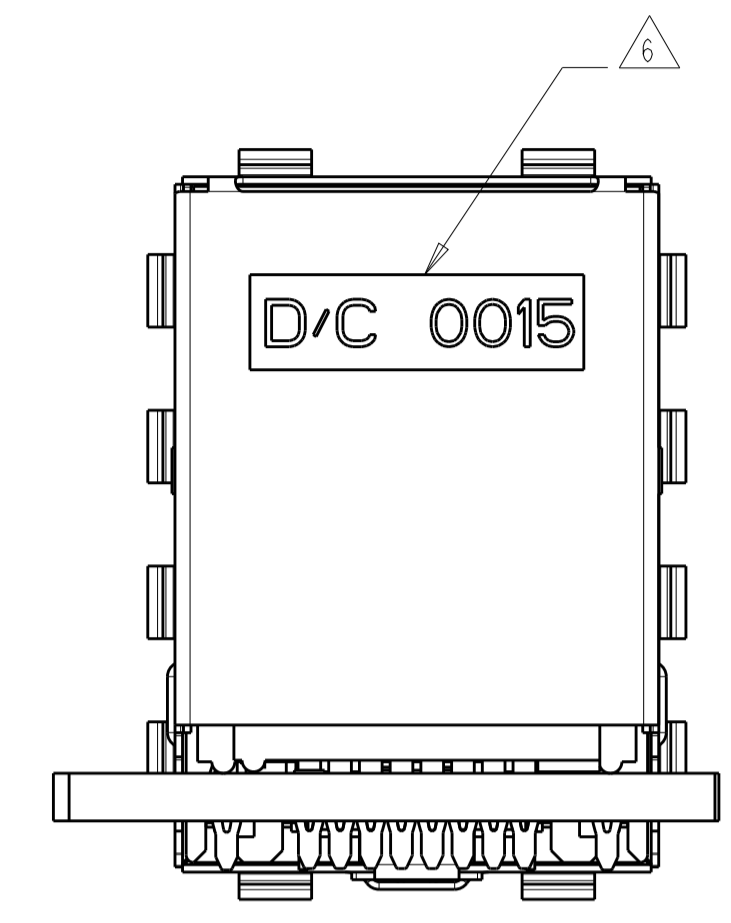

- MATERIAL:
 - HOUSING: PBT POLYESTER, BLACK, UL 94V-0.
 - TERMINALS: 0.33 THICK PHOSPHOR BRONZE PLATED WITH 1.27um MINIMUM THICK HARD GOLD IN LOCALIZED AREA AND 2.0um MINIMUM THICK MATTE TIN IN ACTION PIN COMPLIANT PIN TERMINAL AREA OVER 1.27um MINIMUM THICK NICKEL UNDERPLATE.
 - SHIELD: 0.25 THICK COPPER ALLOY PLATED WITH 2.03um MINIMUM TIN OVER 1.27 um MINIMUM NICKEL
 - GROUNDING CLIP: 0.25 THICK COPPER ALLOY PRE-PLATED WITH 2.03um MINIMUM MATTE TIN OVER 1.27um MINIMUM NICKEL
 - LIGHT EMITTING DIODE (LED): DIFFUSED EPOXY LENS, 12.95 CARBON STEEL WIREFRAME LEADS PREPLATED WITH 8.89um THK. TIN/COPPER OVER 2.03um THK. SILVER OVER 1.02um COPPER OVER 3.56um THK. NICKEL OVER 1.02um THK. COPPER UNDERPLATE
 - LED ACTION PIN - COMPLIANT PIN CONTACTS: 0.3 THICK BRASS PLATED WITH 2um MINIMUM MATTE TIN OVER 1.27um MINIMUM NICKEL UNDERPLATE.
- JACK CAVITY CONFORMS TO FCC RULES AND REGULATIONS, PART 68 SUBPART F.
 - MAXIMUM PIN LENGTH 3.40 FROM TOP SURFACE OF PC BOARD.
 - FINISHED PLATED THRU HOLE DIAMETER - ANNULAR RING DIAMETER 1.3 TO 1.5
 - DATUMS AND BASIC DIMENSIONS ESTABLISHED BY CUSTOMER
 - DATE CODE LOCATED ON REAR OF PART APPROXIMATELY AS SHOWN
 - CONTACTS ARE NOT INTENDED TO BE ALIGNED WITH EACH OTHER
 - SUGGESTED OPERATING CURRENT FOR LEDS IS 20 mA
 - PCB THROUGH HOLES FOR LED #1 AND LED #4 ARE NOT REQUIRED FOR 1888653-5,6,1-1888653-1.
 - THE PN 1-1888653-1 LED DOMINANT WAVELENGTH: GREEN 525nm TYP. YELLOW 590nm TYP.

ATCA PANEL AND PRINTED CIRCUIT BOARD ASSEMBLY LAYOUT

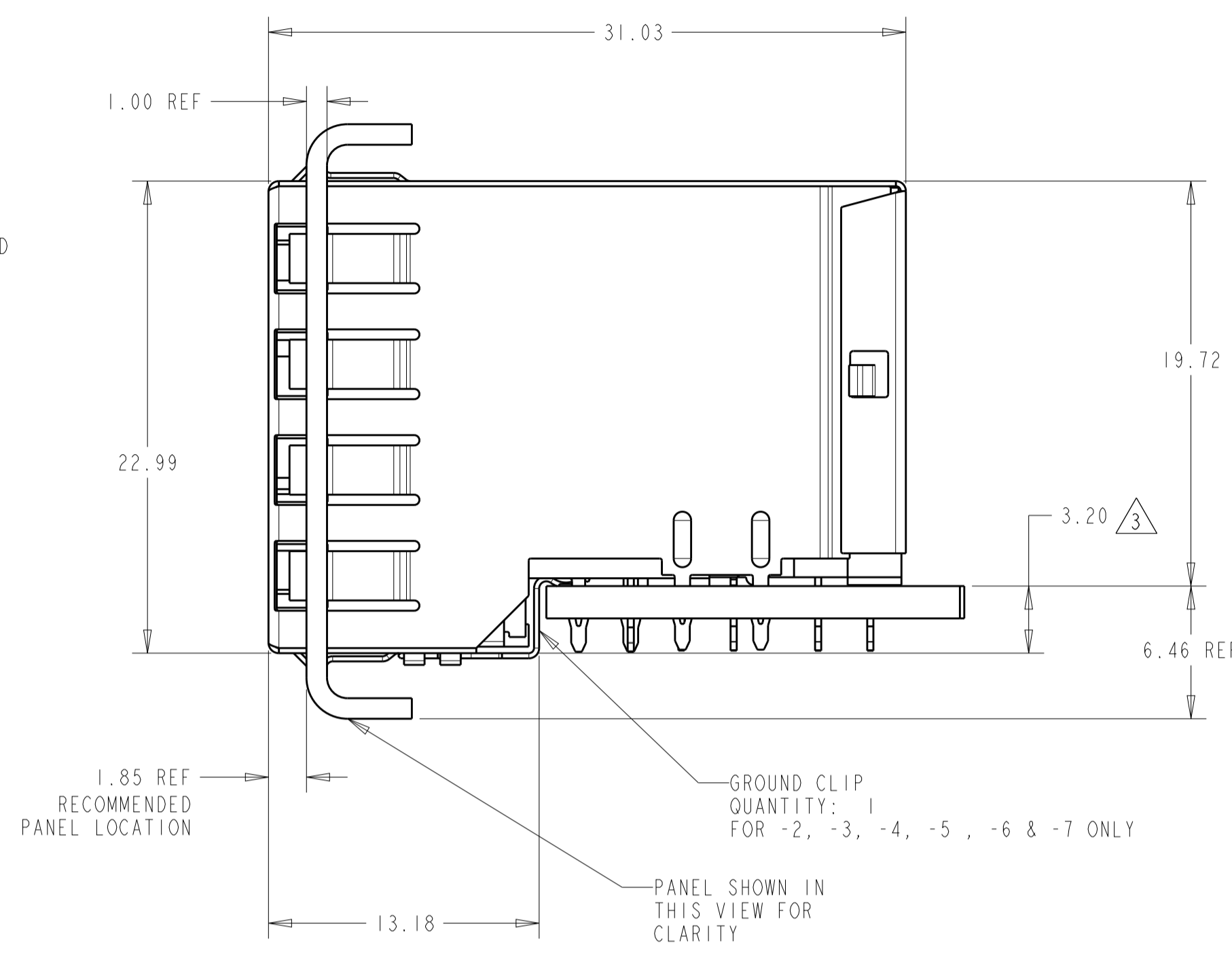
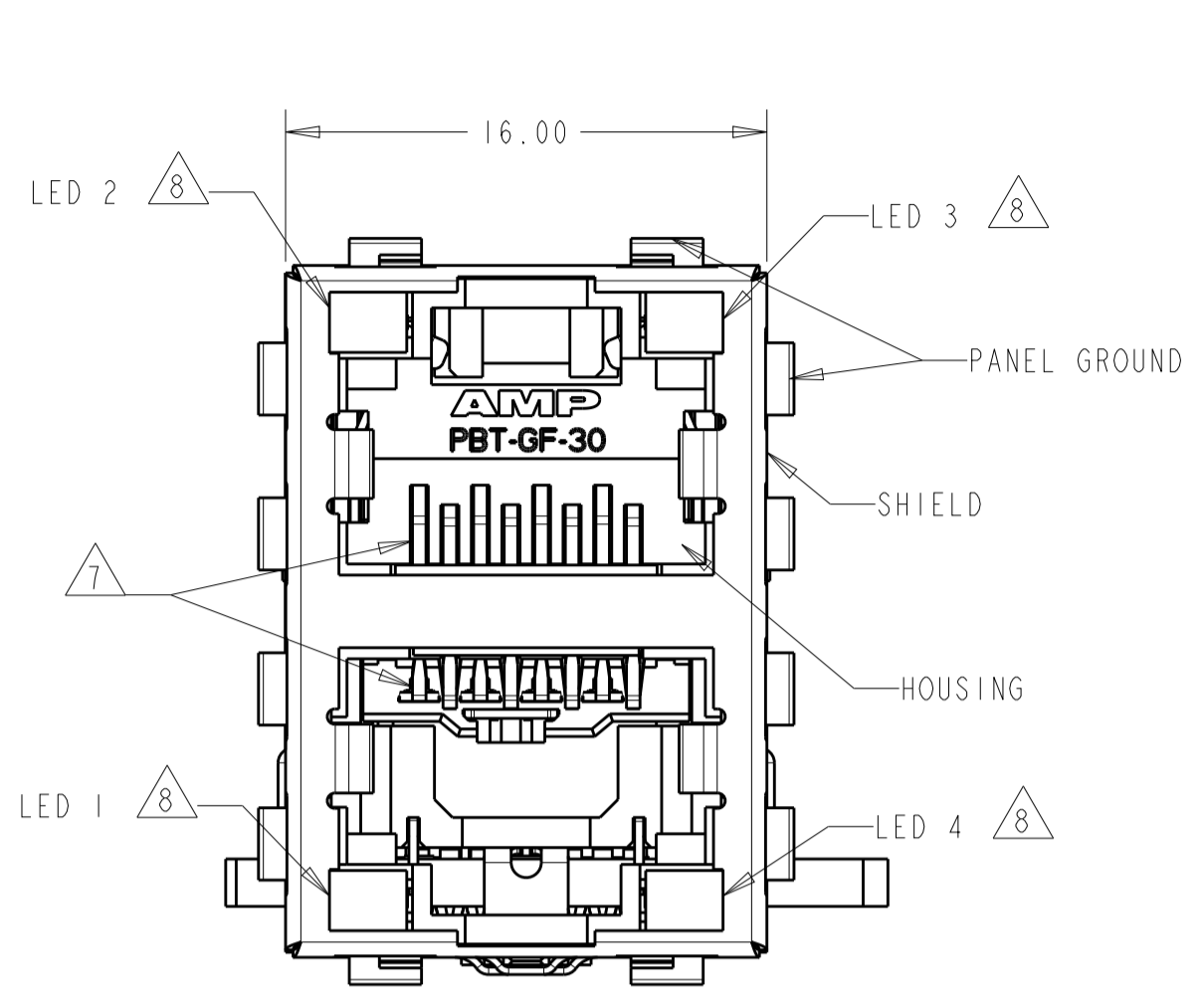
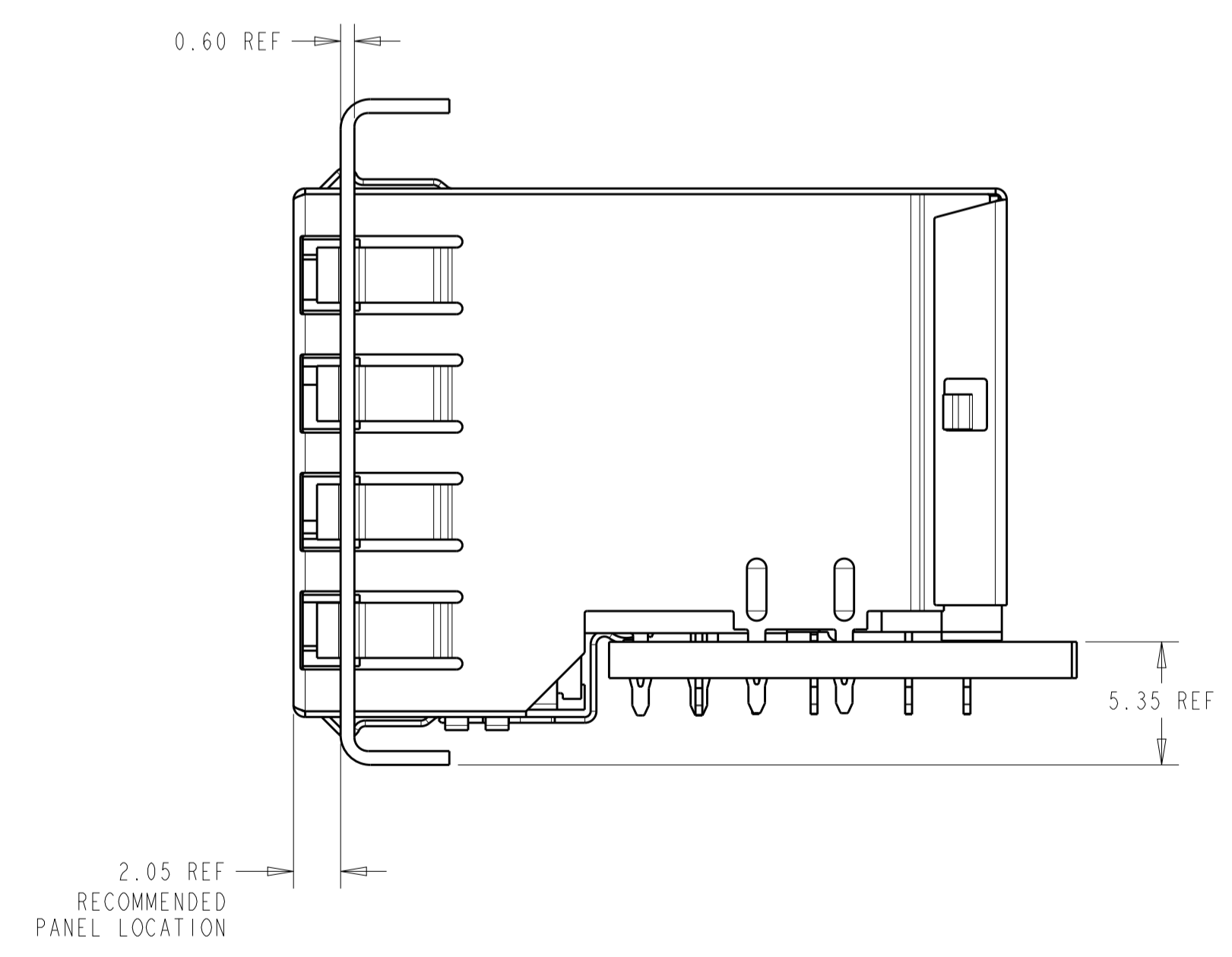

AMC PANEL AND PRINTED CIRCUIT BOARD ASSEMBLY LAYOUT

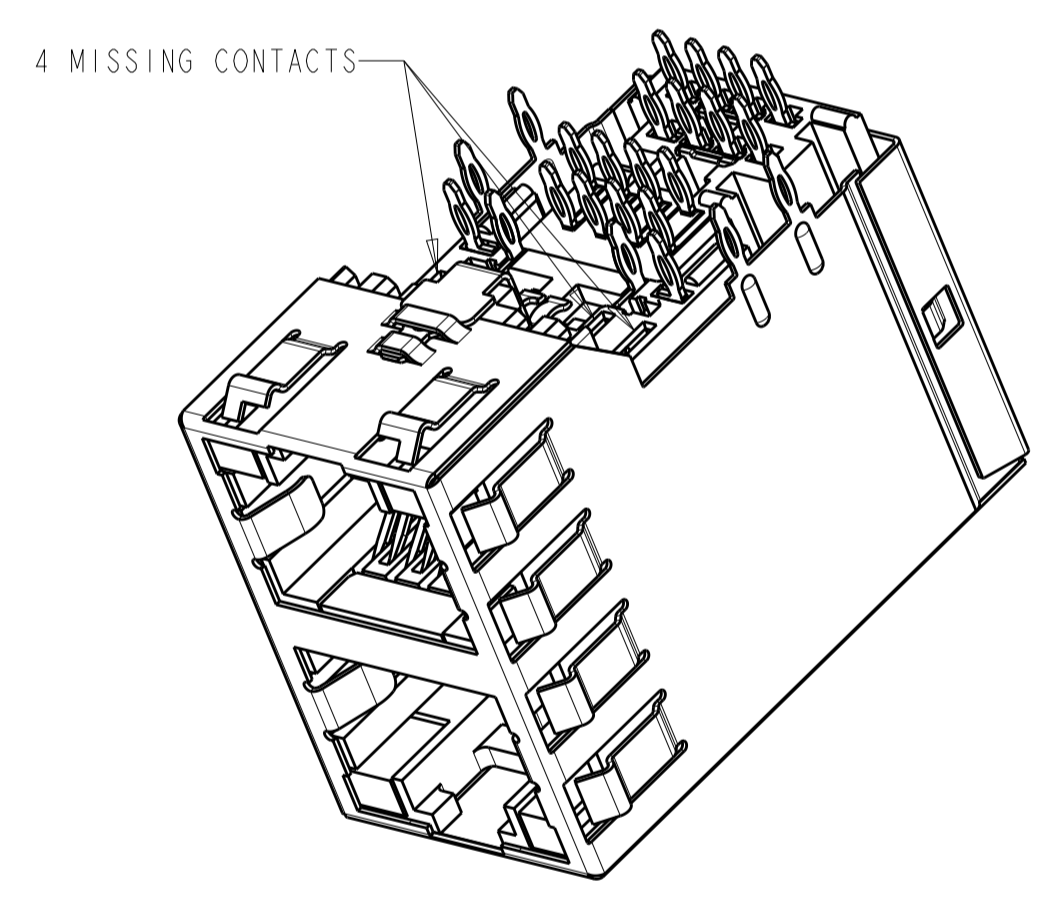

1888653-5,-6
 (REPRESENTATION OF -5,-6 SHOWN IN THIS VIEW ONLY)

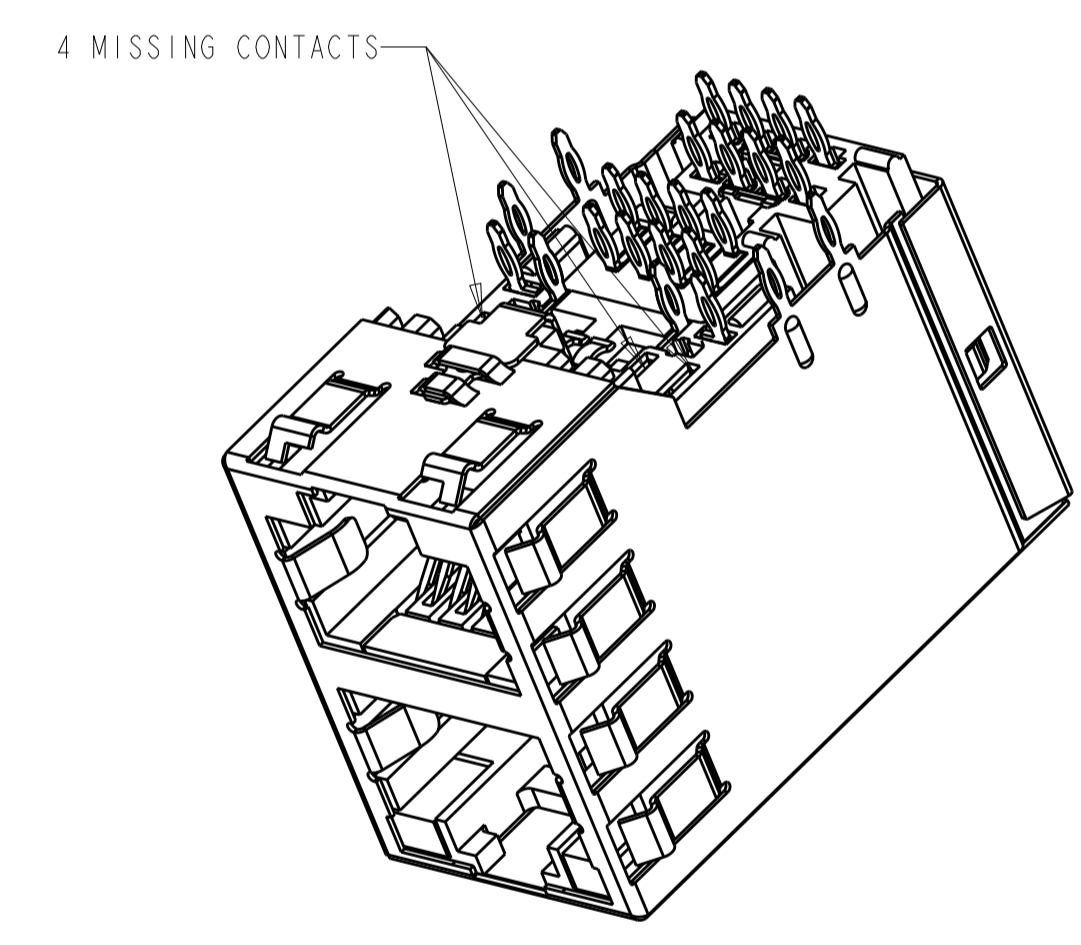

1-1888653-1
 SCALE 3:1

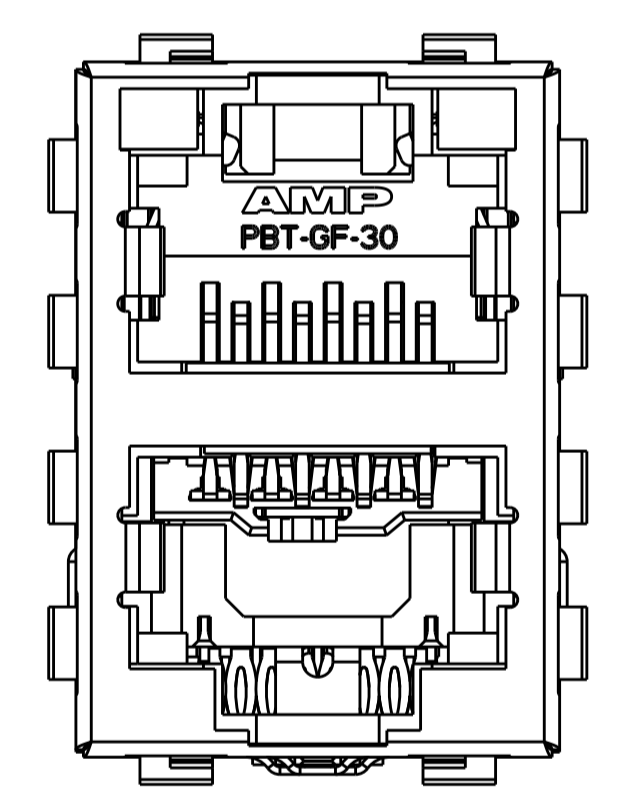

1-1888653-1
 SCALE 4:1

15.88	NONE	GREEN/YELLOW	GREEN/YELLOW	NONE	WITH GROUND CLIP	1-1888653-1
15.88	NONE	GREEN	YELLOW	NONE	WITH GROUND CLIP	1888653-9
15.88	YELLOW	GREEN	GREEN	GREEN	WITH GROUND CLIP	1888653-7
15.88	NONE	GREEN	GREEN	NONE	WITH GROUND CLIP	1888653-6
15.88	NONE	YELLOW	GREEN	NONE	WITH GROUND CLIP	1888653-5
15.88	YELLOW	YELLOW	GREEN	GREEN	WITH GROUND CLIP	1888653-4
15.88	GREEN	GREEN	YELLOW	YELLOW	WITH GROUND CLIP	1888653-3 (SHOWN)
15.88	GREEN	GREEN	GREEN	GREEN	WITH GROUND CLIP	1888653-2
16.13	GREEN	GREEN	GREEN	GREEN	WITHOUT GROUND CLIP	1888653-1
M DIM	LED #4 (LOWER-RIGHT)	LED #3 (UPPER-RIGHT)	LED #2 (UPPER-LEFT)	LED #1 (LOWER-LEFT)	DESCRIPTION	PART NUMBER

THIS DRAWING IS A CONTROLLED DOCUMENT.

OWN: L.A. MAYER 19OCT2006
 CHG: J. WESTMAN 19OCT2006
 APVD: S. FLICKINGER 19OCT2006

STE TE Connectivity

NAME: STACKED MOD JACK ASSEMBLY, 2 X 1, 8 POSN, RJ45, SHIELDED, PANEL GROUND, OFFSET, CAT 5e

PRODUCT SPEC: 108-1854
 APPLICATION SPEC: 114-2160

SIZE: A1
 CAGE CODE: 00779
 DRAWING NO: 1888653

RESTRICTED TO: -
 SHEET: 1 OF 2
 REV: K

CUSTOMER DRAWING SCALE: 4:1

LOC		DIST		REVISIONS			
P	LTN	DESCRIPTION	DATE	DMN	APVD		
-	-	SEE SHEET 1	-	-	-	-	-

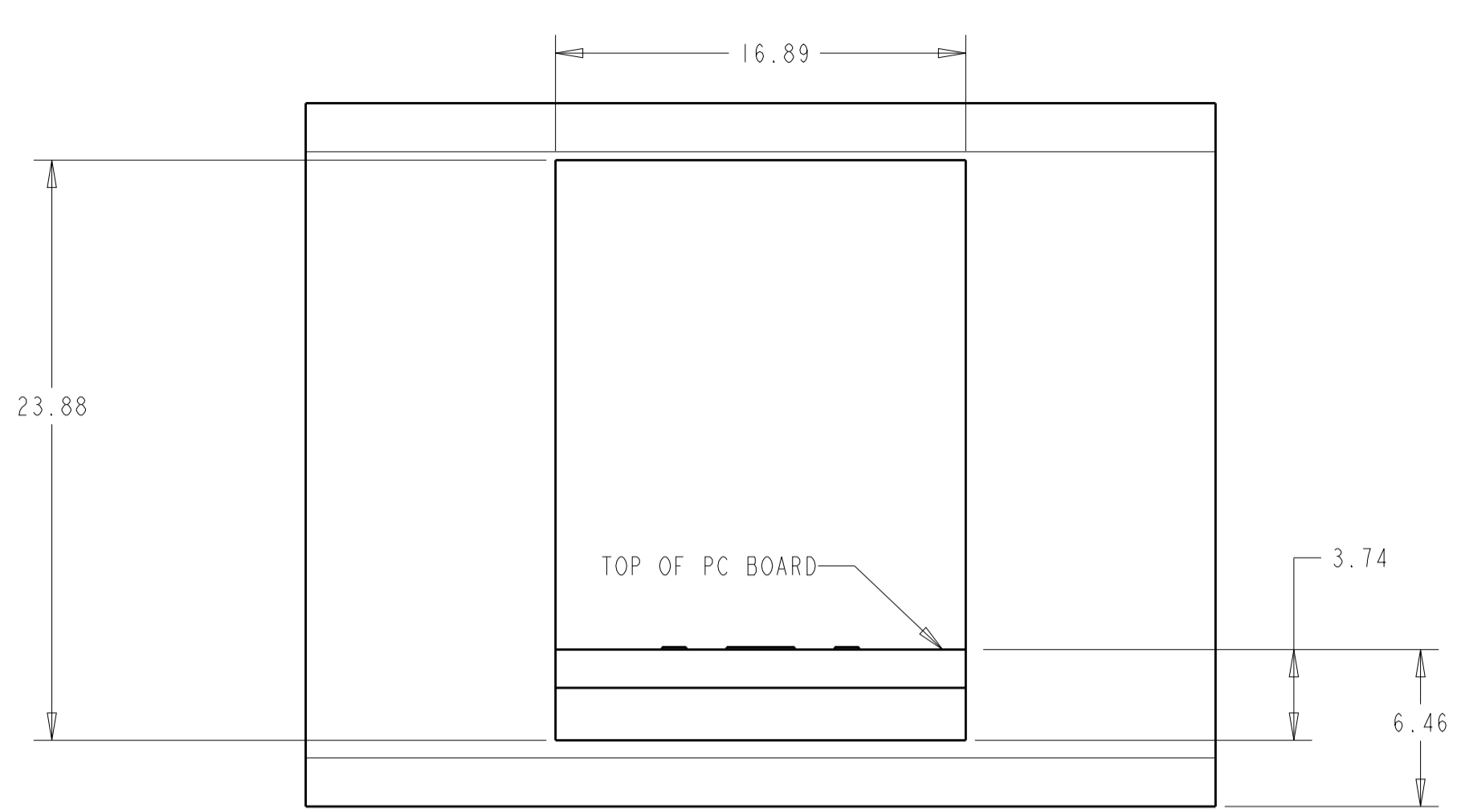

ATCA PANEL AND PRINTED CIRCUIT BOARD LAYOUT

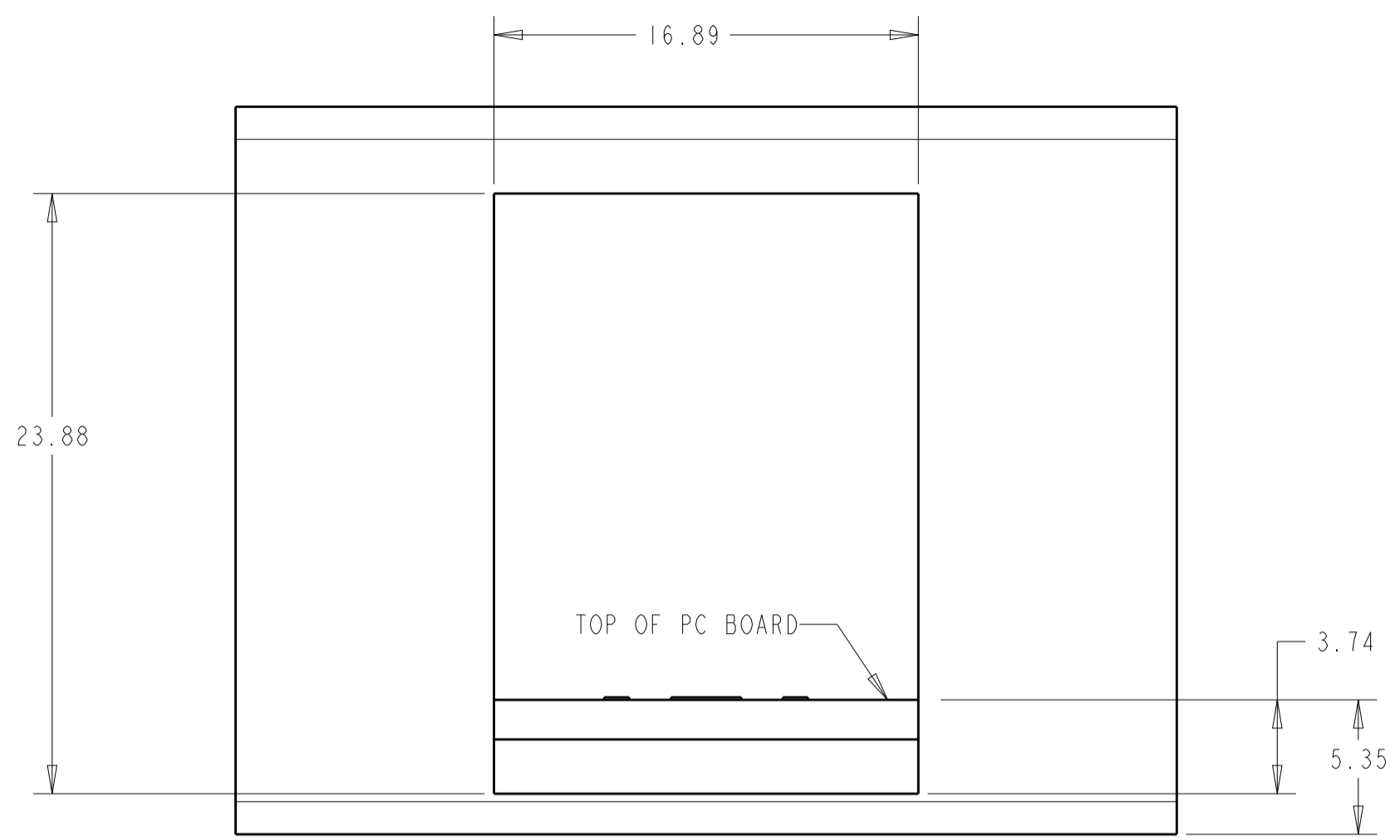

AMC PANEL AND PRINTED CIRCUIT BOARD LAYOUT

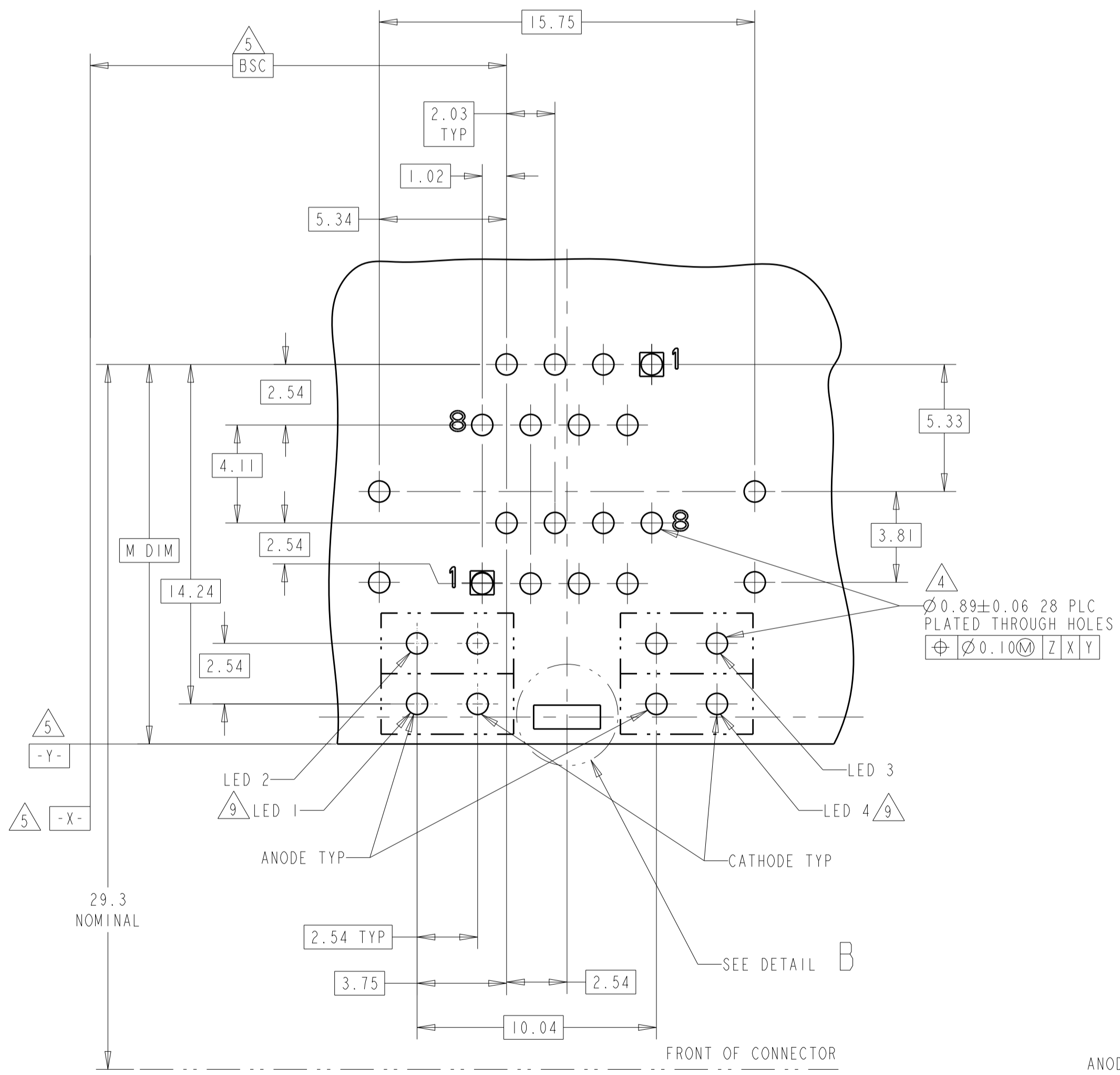

PC BOARD LAYOUT (COMPONENT SIDE)

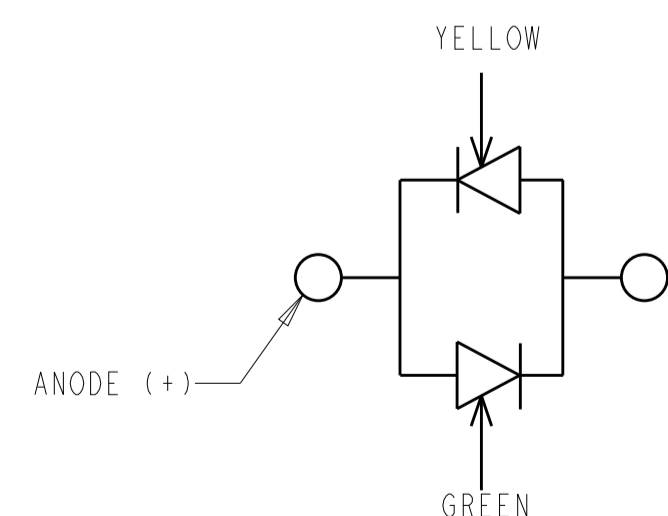
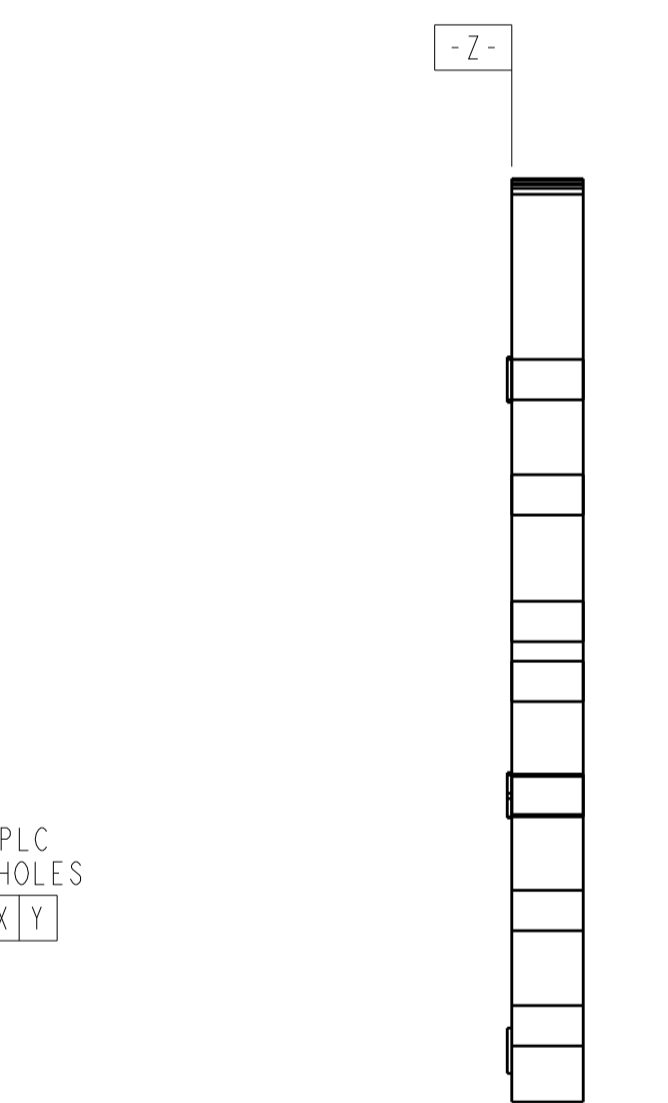

LED CURRENT DIAGRAM FOR 1-1888653-1

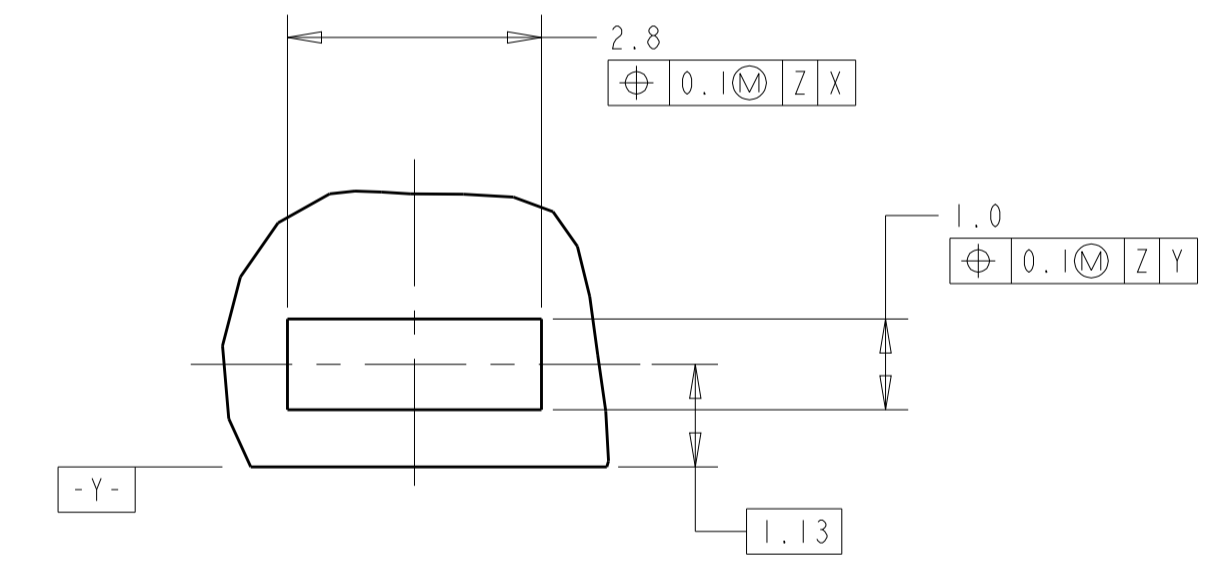

DETAIL B
 SCALE 12:1
 PLATED PADS REQUIRED FOR 1888653 -2, 3, -4, -5, -6 & -7 (PRODUCT WITH GROUNDING CLIPS)

THIS DRAWING IS A CONTROLLED DOCUMENT.		DMN	L.A.MAYER	19OCT2006	TE Connectivity
DIMENSIONS: mm		CHK	J.WESTMAN	19OCT2006	
TOLERANCES UNLESS OTHERWISE SPECIFIED:		APVD	S.FLICKINGER	19OCT2006	NAME STACKED MOD JACK ASSEMBLY, 2 X 1, 8 POSN, RJ45, SHIELDED, PANEL GROUND, OFFSET, CAT 5e
0 PLC ±		PRODUCT SPEC	108-1854	APPLICATION SPEC	
1 PLC ±0.13		SIZE	A1	CAGE CODE	00779
2 PLC ±		DRAWING NO	1888653	RESTRICTED TO	
3 PLC ±		WEIGHT		SCALE	6:1
4 PLC ±		CUSTOMER DRAWING		SHEET	2 OF 2
ANGLES ±1°				REV	K



Компания «ЭлектроПласт» предлагает заключение долгосрочных отношений при поставках импортных электронных компонентов на взаимовыгодных условиях!

Наши преимущества:

- Оперативные поставки широкого спектра электронных компонентов отечественного и импортного производства напрямую от производителей и с крупнейших мировых складов;
- Поставка более 17-ти миллионов наименований электронных компонентов;
- Поставка сложных, дефицитных, либо снятых с производства позиций;
- Оперативные сроки поставки под заказ (от 5 рабочих дней);
- Экспресс доставка в любую точку России;
- Техническая поддержка проекта, помощь в подборе аналогов, поставка прототипов;
- Система менеджмента качества сертифицирована по Международному стандарту ISO 9001;
- Лицензия ФСБ на осуществление работ с использованием сведений, составляющих государственную тайну;
- Поставка специализированных компонентов (Xilinx, Altera, Analog Devices, Intersil, Interpoint, Microsemi, Aeroflex, Peregrine, Syfer, Eurofarad, Texas Instrument, Miteq, Cobham, E2V, MA-COM, Hittite, Mini-Circuits, General Dynamics и др.);

Помимо этого, одним из направлений компании «ЭлектроПласт» является направление «Источники питания». Мы предлагаем Вам помощь Конструкторского отдела:

- Подбор оптимального решения, техническое обоснование при выборе компонента;
- Подбор аналогов;
- Консультации по применению компонента;
- Поставка образцов и прототипов;
- Техническая поддержка проекта;
- Защита от снятия компонента с производства.



Как с нами связаться

Телефон: 8 (812) 309 58 32 (многоканальный)

Факс: 8 (812) 320-02-42

Электронная почта: org@eplast1.ru

Адрес: 198099, г. Санкт-Петербург, ул. Калинина, дом 2, корпус 4, литера А.