

● General Description

RPR-0521RS is a module which integrates optical proximity, digital ambient light sensor IC, and infrared LED (IrLED). Proximity sensor (PS) part detects the human or object approaching by the reflection of IrLED light. Ambient light sensor (ALS) part detects the wide range of illumination; from the dark environment to the direct sun light. The illuminant intensity of LCD display and keypad can be adjusted by using RPR-0521RS. It enables lowering current consumption and/or improving the visibility under the bright environment.

● Features

- 1) Compatible to I²C bus interface (f/s mode support)
- 2) Compatible to 1.8V logic interface
- 3) Low Current consumption by power down function/mode
- 4) There are two ALS outputs; peaks of spectrum responses are in visible light (Data0) and in infrared light (Data1) for calculating illuminance.
- 5) Correspond to very wide range of light intensity
- 6) Rejecting 50Hz/60Hz light noise (ALS function)
- 7) Detection range of proximity sensor is around 1 - 100mm (adjustable by I²C)
- 8) Built-in current configurable IrLED driver

● Application

Smart phone, Mobile phone, Digital Still Camera, Portable game, Camcorder, PDA, LCD display etc.

● Absolute maximum ratings (Ta = 25°C)

Parameter	Symbol	Limits	Units
VDD Supply Voltage	Vddmax	4.5	V
SDA, SCL Terminal Voltage	Vsdamax, Vsclmax	4.5	V
LEDA, LDR, INT Terminal Voltage	Vledamax, Vldrmax, Vintmax	7	V
Operating Temperature	Topr	-25~85	°C
Storage Temperature	Tstg	-30~85	°C
INT, SDA Sink Current	I _{max}	7	mA

● Operating conditions

Parameter	Symbol	Min.	Typ.	Max.	Units
VDD Supply Voltage	Vdd	2.5	3.0	3.6	V
VLEDA Voltage	Vleda	2.8	3.0	5.5	V
INT Terminal Voltage	Vint	—	—	5.5	V

●Electrical characteristics

(VDD= 3.0V, Ta = 25°C, and all registers are default unless otherwise noted.)

Parameter	Symbol	Min.	Typ.	Max.	Units	Conditions
Supply current for ALS	Icc1	10	90	300	uA	EV = 10 lx*1 MODE_CONTROL(41h) =89h
Supply current for PS	Icc2	10	90	200	uA	MODE_CONTROL(41h) =49h
Standby mode current	Icc3	0.1	1.0	2.0	uA	MODE_CONTROL(41h)=00h, No input light
Calculated Lx	Lx	6	10	14	lx	EV = 10 lx*1 MODE_CONTROL(41h)=89h ALS_PS_CONTROL(42h)=02h
Dark (0 lx) Sensor out in TYPE0	SO_0	—	—	5	count	No input light MODE_CONTROL(41h)=89h ALS_PS_CONTROL(42h)=02h
Dark (0 lx) Sensor out in TYPE1	SO_1	—	—	5	count	No input light MODE_CONTROL(41h)= 89h ALS_PS_CONTROL(42h)=02h
PS sensor out (d=50mm ²)	PS50	48	80	112	count	MODE_CONTROL(41h)=49h LED current =100mA
PS sensor out (No proximity object)	PS0	—	—	10	count	Ambient irradiance = 0uW/cm ² MODE_CONTROL(41h)=49h LED current =100mA
ILED pulse duration 1	twILED 1	80	200	300	us	MODE_CONTROL(41h)=49h
ILED pulse duration 2	twILED 2	110	330	500	us	MODE_CONTROL(41h)=69h
LDR terminal sink current at LDR terminal voltage = 1.3V	ILED	22	25	28	mA	ALS_PS_CONTROL (42h) <1:0> = "00"
INT output 'L' Voltage	VINTL	0	—	0.4	V	lint = 3mA
SCL SDA input 'H' Voltage	VIH	1.26	—	—	V	
SCL SDA input 'L' Voltage	VIL	—	—	0.54	V	
SCL SDA input 'H'/'L'Current	IIHL	-10	—	10	uA	
I ² C SDA Output 'L' Voltage	VOL	0	—	0.4	V	lol = 3mA

*1 White LED is used as optical source. "Lx" is calculated from ADC count valus.

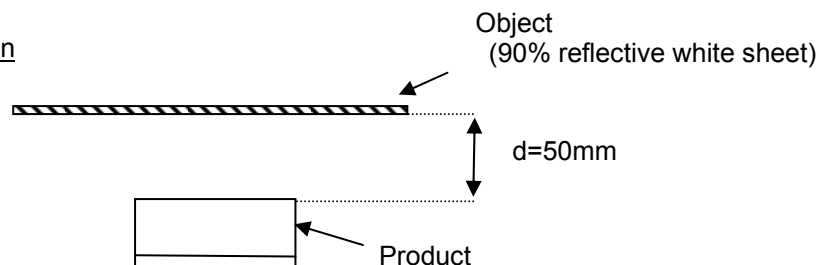
*2 Measuring Condition

Object: 90% reflective white sheet (50×50mm Kodak Gray Card Plus)

Distance between the object and the product is 50mm. No glass or apertures is above the product.

● Transmitter Electrical characteristics (Ta = 25°C, unless otherwise noted.)

Parameter	Symbol	Min.	Typ.	Max.	Units	Conditions
LED Forward Voltage	VF	—	1.6	1.95	V	LED current =100mA
LED Peak Emission Wavelength	λ_p	—	940	—	nm	

● I²C bus timing characteristics (VDD= 3.0V, Ta = 25°C, unless otherwise noted.)

Parameter	Symbol	Min.	Typ.	Max.	Units	Conditions
I ² C SCL Clock Frequency	f _{SCL}	0	—	400	kHz	
I ² C START Condition Hold Time	t _{HD;STA}	0.6	—	—	us	
I ² C 'L' Period of the SCL Clock	t _{LOW}	1.3	—	—	us	
I ² C 'H' Period of the SCL Clock	t _{HIGH}	0.6	—	—	us	
I ² C S START Condition Set up time	t _{SU;STA}	0.6	—	—	us	
I ² C Data Hold Time	t _{HD;DAT}	0	—	—	us	
I ² C Data Setup Time	t _{SU;DAT}	100	—	—	ns	
I ² C STOP Condition Set up Time	t _{SU;STO}	0.6	—	—	us	
I ² C Bus Free Time	t _{BUF}	1.3	—	—	us	
I ² C Data Vaild Time	t _{VD;DAT}	—	—	0.9	us	
I ² C Data Vaild Acknowledge Time	t _{VD;ACK}	—	—	0.9	us	

I²C bus F/S-mode timing diagram

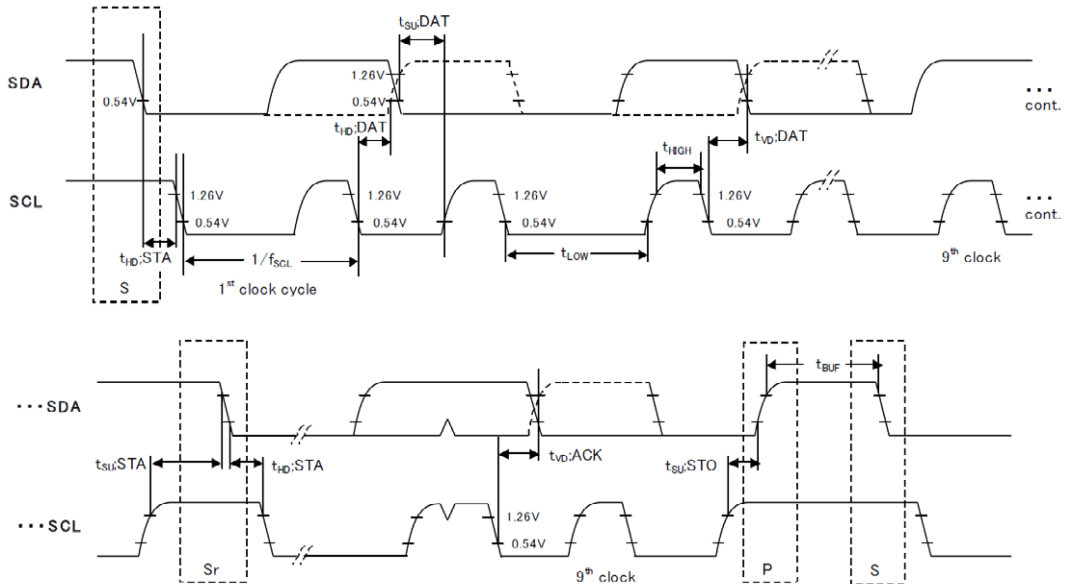

● Package outlines

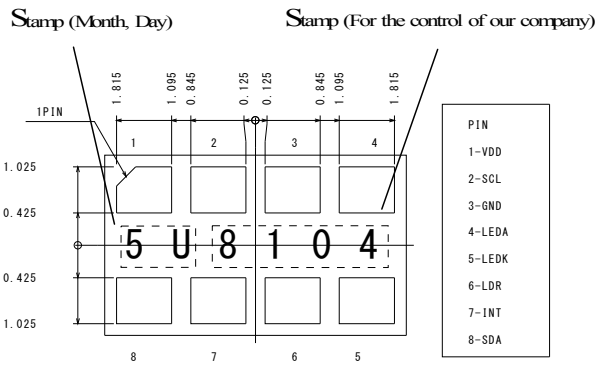
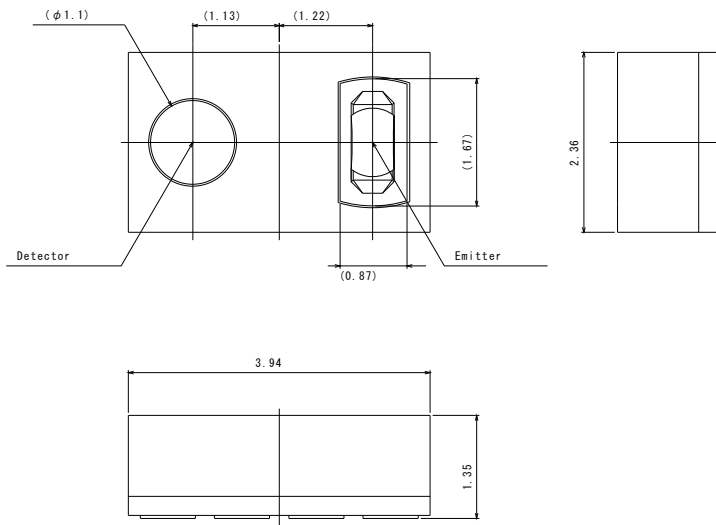

1) Unit: mm

2) Tolerance shall be ± 0.2 mm unless otherwise noted.

PIN Number	Symbol	Description
1	VDD	Supply Voltage
2	SCL	I ² C Clock, Input
3	GND	Ground
4	LEDA	LED Supply Voltage
5	LEDK	LED Cathode
6	LDR	LED Driver
7	INT	PS or ALS Interrupt Pin, Open Drain
8	SDA	I ² C Serial Data, Input/Output

● Block diagram and block explanation

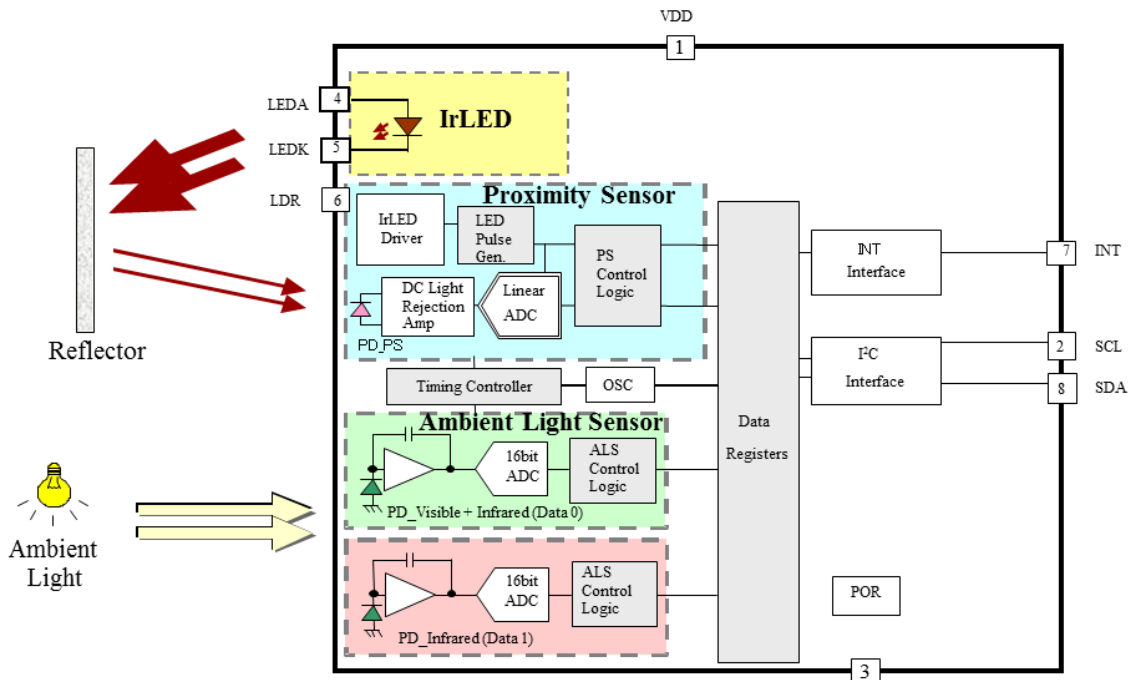

- I²C Interface
I2C bus interface. f/s mode. 1.8V interface.
- POR
Power on reset function.
- OSC
Internal oscillator.
- Timing Controller
Internal management block for proximity sensor and ambient light sensor.
- PS Control Logic
This block controls proximity sensor ADC.
- LED Pulse Gen
LED current generator. LED current can be adjusted by ALS_PS_CONTROL (42h) register.
- IrLED Driver.
IrLED driver block.
- PD_Visible + Infrared, PD_Infrared
Photo diodes for ambient light sensor.
- 16bit ADC
AD converter for ALS.
- ALS Control Logic
This block controls ambient light sensor ADC.
- PD_PS
Photo diode for proximity sensor.
- DC Light Rejection Amp
DC light is rejected in this block.
- Linear ADC
AD converter for proximity sensor.

● Terminal description

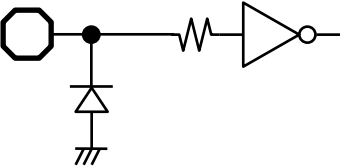
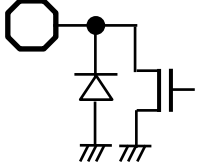
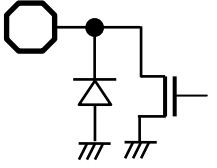
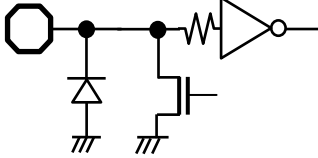
PIN No.	Terminal Name	Equivalent Circuit	Function
1	VDD		Power supply terminal
2	SCL		I ² C bus Interface SCL terminal
3	GND		GND terminal
4	LEDA		LED supply voltage
5	LEDK		LED Cathode, Please connect to LDR PIN when using internal LED driver circuit.
6	LDR		Nch open drain LED terminal. LED current and emitting pulse width can be defined by internal register.
7	INT		Nch open drain output. Interrupt setting is defined by internal register.
8	SDA		C bus Interface SDA terminal

● Structure figure

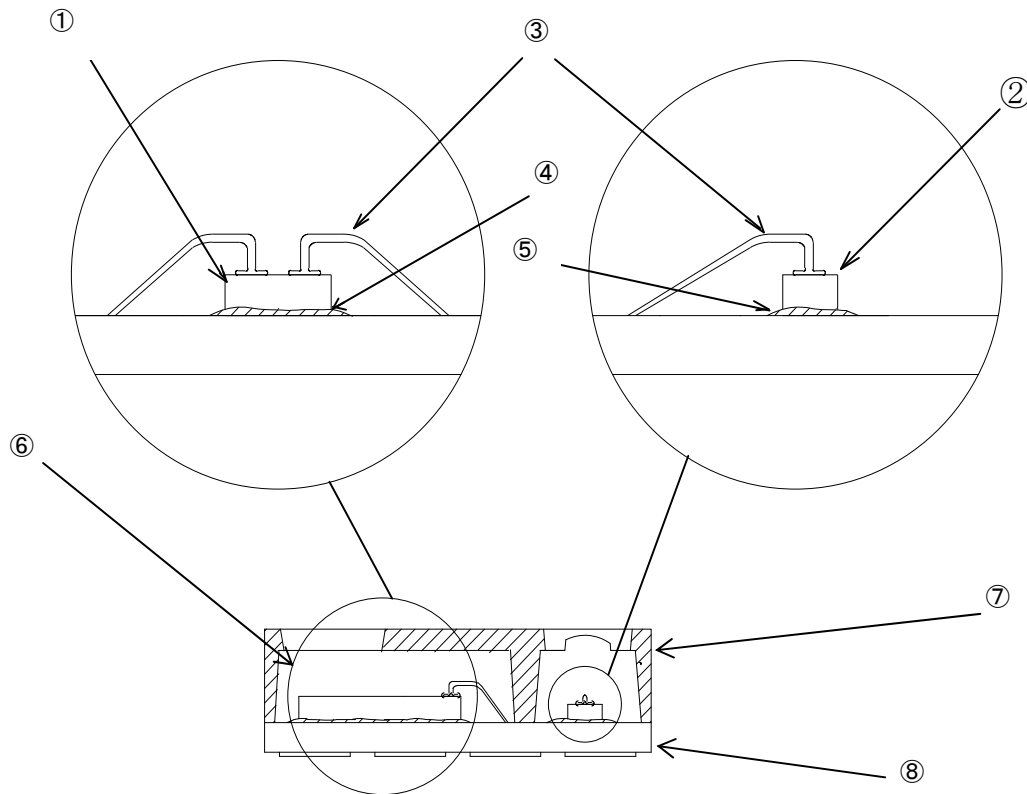

NO.	Name	Material
①	LSI	Si
②	Ir LED	GaAlAs
③	Au wire	Au
④	Insulating bonding paste	Epoxy resin
⑤	Conductive bonding paste	Ag + Epoxy resin
⑥	Transparent mold resin	Epoxy resin
⑦	Light-resistant mold resin	Epoxy resin
⑧	PCB	Epoxy resin Cu,Ni,Au(Electrode)

● Taping standard

Note) 1.Unspecified tolerance shall be ± 0.2 .
2.Dimensions and marking of reels are in accordance with JEITA's standard ET-7103A.

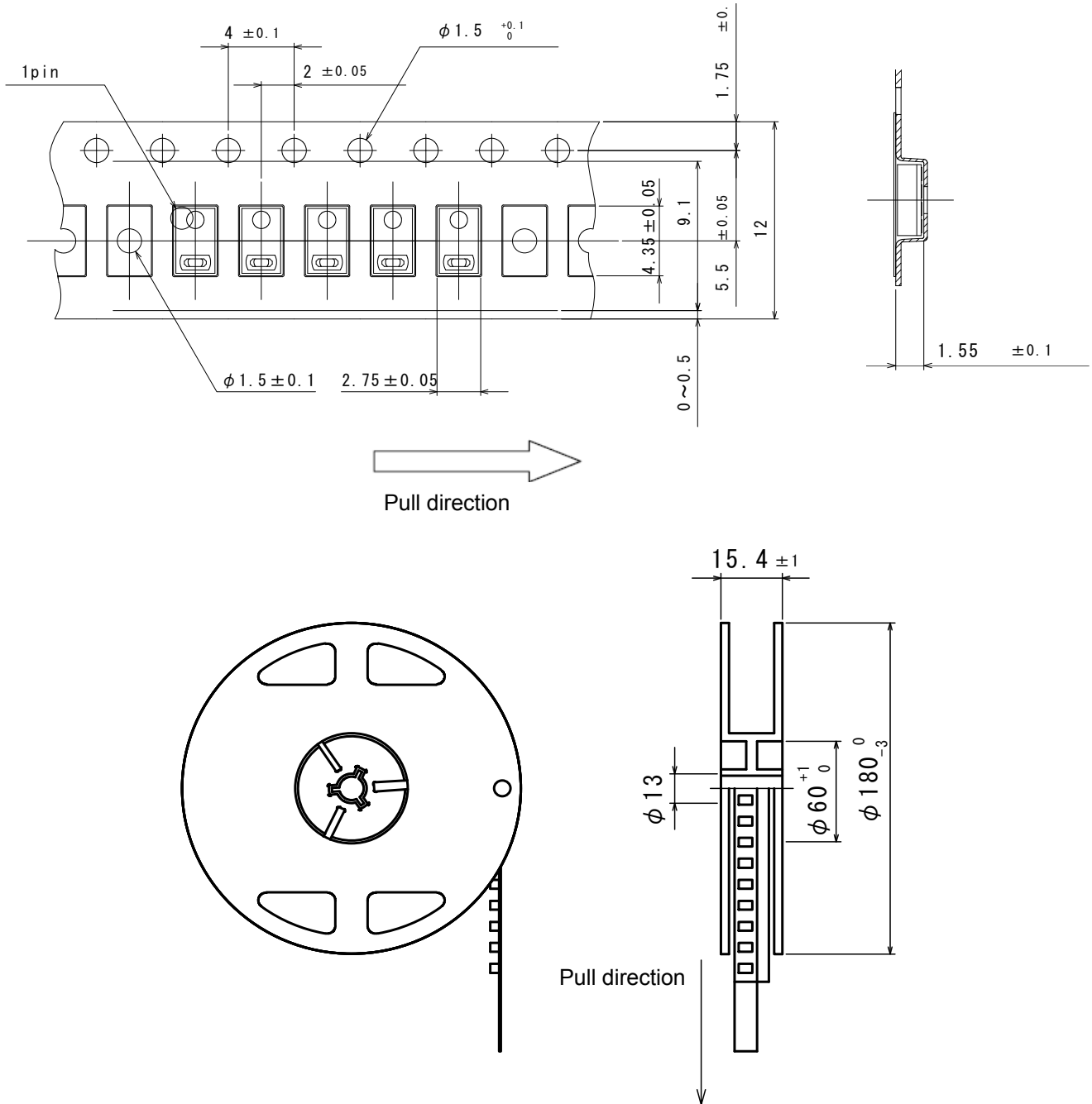

Packaging quantity: 2,500 pcs/reel

● Packaging requirements

1. Packaging

- (1) Quantity per reel is 2,500pcs
- (2) Each reel are packed in aluminum bag.
The size of aluminum bag is 240(a)×240(b)mm.
- (3) Aluminum bag is pressure sealed on all four directions.

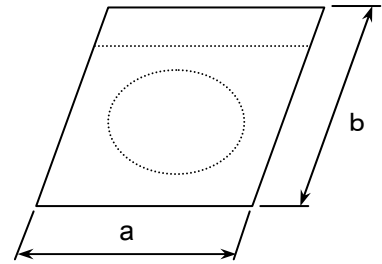

2. Label indication

The following information shall be described on a aluminum bag label; ROHM type number, packaging quantity, and lot number

【Example】

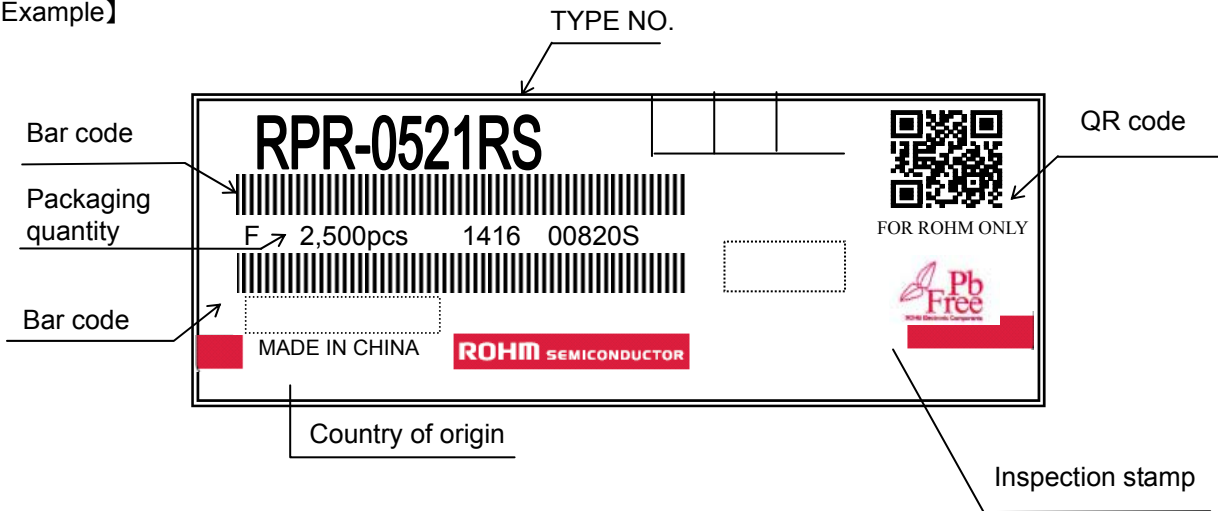

【Example of lot number marking】

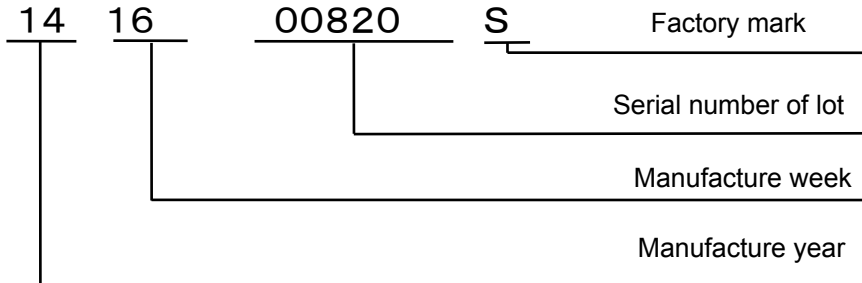

3. Factory (Country of origin)

- ROHM ELECTRONICS DALIAN CO., LTD. (CHINA)

Attention points in handling

This product is developed as an optical proximity sensor and ambient light sensor with IrLED; suitable for reflow soldering. Please take care of following points when using this device.

1. Storage

There will be the possibility that the moisture influences the reliability of this product during the reflow soldering process. Hence, the product is packed in the anti-moisture bag. When using the product, please keep following conditions.

- ① Storage condition
 - Storage Temperature : 5 ~ 30°C
 - Storage Humidity : less than 70%RH
- ② Process after opening the bag
 - Please storage the product at the temperature between 5 ~ 30°C and the moisture less than 70% RH within 168 hours.
- ③ Baking (dry) process
 - If the above conditions aren't kept, please apply the baking process. The baking process should be executed under the reel condition at 60°C±5°C for 12~24 hours. During the baking process, the reel and emboss tape should be handled with care.

2. Designing of PCB

The figure below is the recommended solder pattern. This pattern may need to be adjusted to mounting conditions and solder paste.

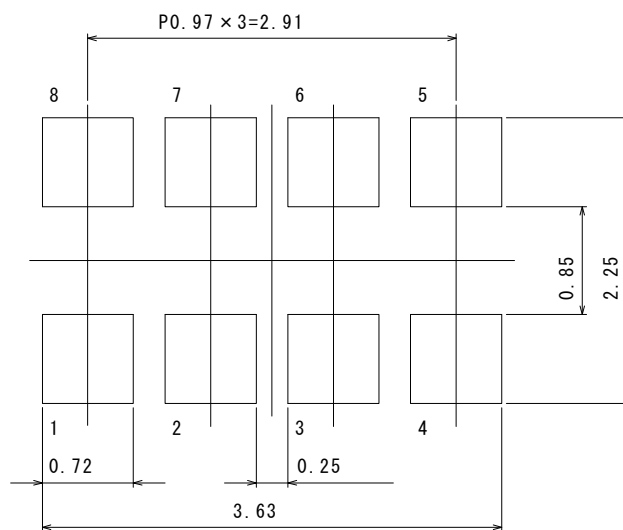

3. Reflow soldering

Number of reflow process shall be less than 2 times. When the second reflow process is performed, the interval between the first and the second reflow process shall be as short as possible to prevent absorption of moisture into the resin of the product. Cooling process to the room temperature shall be required between the first and the second reflow process.

The following temperature condition is recommended for the reflow soldering. We would like you to evaluate your reflow condition because the condition is affected by the PCB size, the product heat-resistivity or the mount density

4. Reflow temperature profile

Package surface temperature (°C)

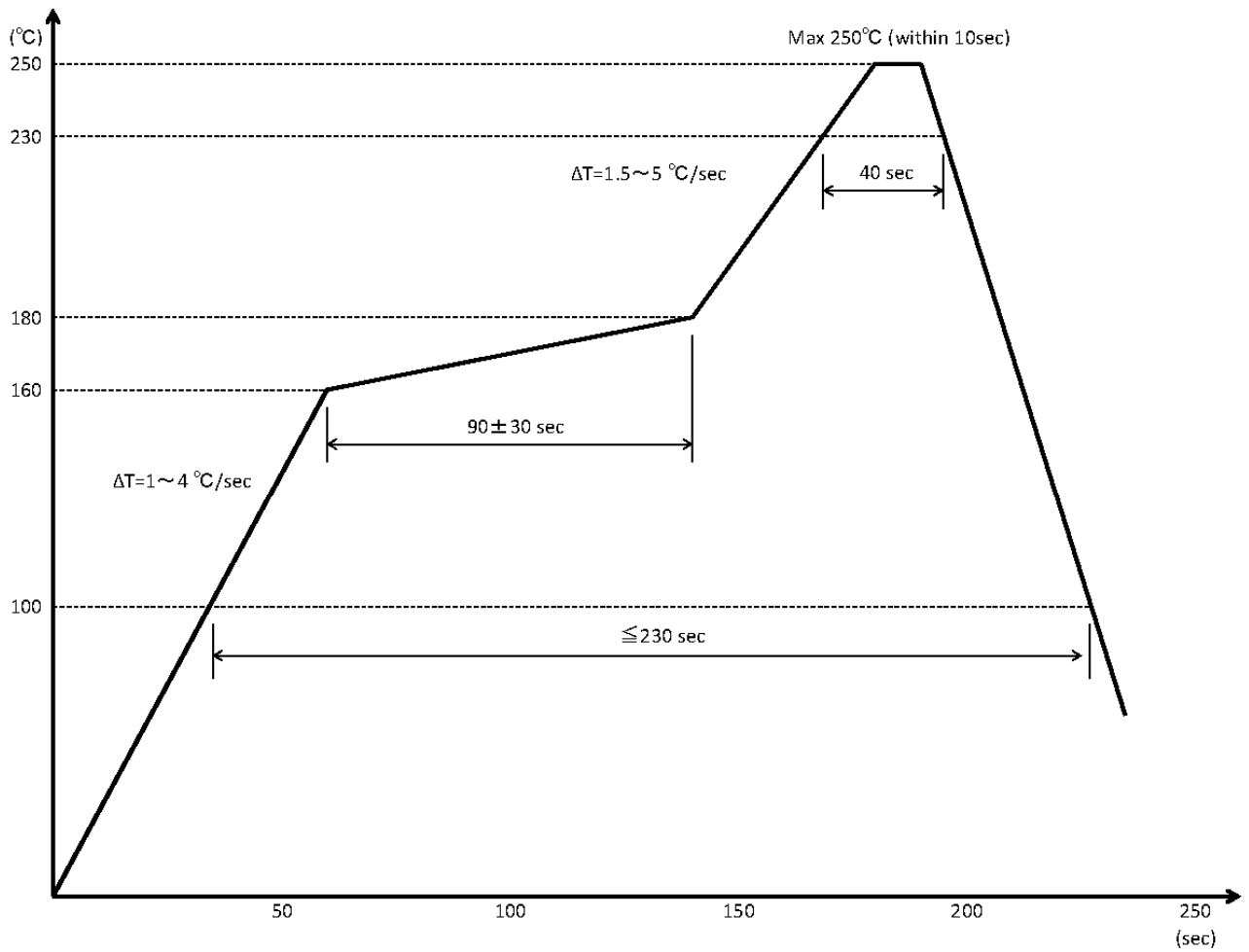

● Command set

Address	TYPE	default	Register name	Register function
40h	RW	0Ah	SYSTEM_CONTROL	System control
41h	RW	00h	MODE_CONTROL	ALS, PS function setting
42h	RW	02h	ALS_PS_CONTROL	ALS Gain, PS LED Driver
43h	RW	01h	PS_CONTROL	PS Gain, PS interrupt persistence
44h	R	00h	PS_DATA_LSBs	PS data low byte
45h	R	00h	PS_DATA_MSBs	PS data high byte
46h	R	00h	ALS_DATA0_LSBs	ALS DATA0 low byte
47h	R	00h	ALS_DATA0_MSBs	ALS DATA0 high byte
48h	R	00h	ALS_DATA1_LSBs	ALS DATA1 low byte
49h	R	00h	ALS_DATA1_MSBs	ALS DATA1 high byte
4Ah	RW	00h	INTERRUPT	Interrupt control
4Bh	RW	FFh	PS_TH_LSBs	PS upper threshold low byte
4Ch	RW	0Fh	PS_TH_MSBs	PS upper threshold high byte
4Dh	RW	00h	PS_TL_LSBs	PS lower threshold low byte
4Eh	RW	00h	PS_TL_MSBs	PS lower threshold high byte
4Fh	RW	FFh	ALS_DATA0_TH_LSBs	ALS DATA0 upper threshold low byte
50h	RW	FFh	ALS_DATA0_TH_MSBs	ALS DATA0 upper threshold high byte
51h	RW	00h	ALS_DATA0_TL_LSBs	ALS DATA0 lower threshold low byte
52h	RW	00h	ALS_DATA0_TL_MSBs	ALS DATA0 lower threshold high byte
53h	RW	00h	PS_OFFSET_LSBs	PS offset low byte
54h	RW	00h	PS_OFFSET_MSBs	PS offset high byte
92h	R	E0h	MANUFACT_ID	MANUFACT ID

● SYSTEM_CONTROL (40h)

Field	Bit	TYPE	Description
SW reset	7	RW	0 : initial reset is not started 1 : initial reset is started
INT reset	6	RW	0 : INT pin status is not initialized 1 : INT pin become inactive (high impedance)
Part ID	5 : 0	R	001010

default value 0Ah

● MODE_CONTROL (41h)

Field	Bit	TYPE	Description
ALS_EN	7	RW	0 : ALS Standby 1 : ALS Enable
PS_EN	6	RW	0 : PS Standby 1 : PS Enable
PS_PULSE	5	RW	0 : PS LED pulse width is typ 200us 1 : PS LED pulse width is typ 330us (PS sensor out is doubled)
PS Operating mode	4	RW	0 : normal mode 1 : twice measurement mode
Measurement time	3 : 0	RW	Shown in table below

default value 00h

Value	ALS	PS	Value	ALS	PS
0000	standby	standby	1000	400ms * ₁	50ms
0001	standby	10ms	1001	400ms * ₁	100ms
0010	standby	40ms	1010	400ms * ₂	standby
0011	standby	100ms	1011	400ms * ₂	400ms
0100	standby	400ms	1100	50ms * ₃	50ms
0101	100ms	50ms	1101	Forbidden	
0110	100ms	100ms	1110	Forbidden	
0111	100ms	400ms	1111	Forbidden	

*₁ Measurement time is 100ms, sleep time is 300ms.*₂ High sensitivity mode, measurement time is 400ms.*₃ Additional software process is necessary. Please refer to P.18

● ALS_PS_CONTROL (42h)

Field	Bit	TYPE	Description
Reserved	7 : 6	RW	Write 00
ALS DATA0 GAIN	5 : 4	RW	Gain control of ALS DATA 0 00 : x1 Gain mode 01 : x2 Gain mode 10 : x64 Gain mode 11 : x128 Gain mode
ALS DATA1 GAIN	3 : 2	RW	Gain control of ALS DATA 1 00 : x1 Gain mode 01 : x2 Gain mode 10 : x64 Gain mode 11 : x128 Gain mode
LED CURRENT	1 : 0	RW	00 : 25mA 01 : 50mA 10 : 100mA 11 : 200mA

default value 02h

● PS_CONTROL (43h)

Field	Bit	TYPE	Description
Ambient_Ir_Flag	7 : 6	R	00: Ambient infrared level is low 01: Ambient infrared level is high 11: Ambient infrared level is too high
PS_GAIN	5 : 4	RW	00: PS GAIN ×1 01: PS GAIN ×2 10: PS GAIN ×4 11: Forbidden
PERSISTENCE	3 : 0	RW	PS interrupt persistence setting 0000: Interrupt becomes active at each measurement end 0001: Interrupt status is updated at each measurement end 0010: Interrupt status is updated if two consecutive threshold judgments are the same 0011 or more: Interrupt status is updated if threshold judgments are the same over consecutive set times

default value 01h

● PS_DATA_LSBs (44h)

Register	TYPE	7	6	5	4	3	2	1	0
PS_DATA_LSBs	R	2 ⁷	2 ⁶	2 ⁵	2 ⁴	2 ³	2 ²	2 ¹	2 ⁰

default value 00h

● PS_DATA_MSBs (45h)

Register	TYPE	7	6	5	4	3	2	1	0
PS_DATA_MSBs	R	0	0	0	0	2 ¹¹	2 ¹⁰	2 ⁹	2 ⁸

default value 00h

● ALS_DATA0_LSBs(46h)

Register	TYPE	7	6	5	4	3	2	1	0
ALS_DATA0_LSBs	R	2 ⁷	2 ⁶	2 ⁵	2 ⁴	2 ³	2 ²	2 ¹	2 ⁰

default value 00h

● ALS_DATA0_MSBs(47h)

Register	TYPE	7	6	5	4	3	2	1	0
ALS_DATA0_MSBs	R	2 ¹⁵	2 ¹⁴	2 ¹³	2 ¹²	2 ¹¹	2 ¹⁰	2 ⁹	2 ⁸

default value 00h

● ALS_DATA1_LSBs(48h)

Register	TYPE	7	6	5	4	3	2	1	0
ALS_DATA1_LSBs	R	2 ⁷	2 ⁶	2 ⁵	2 ⁴	2 ³	2 ²	2 ¹	2 ⁰

default value 00h

● ALS_DATA1_MSBs(49h)

Register	TYPE	7	6	5	4	3	2	1	0
ALS_DATA1_MSBs	R	2 ¹⁵	2 ¹⁴	2 ¹³	2 ¹²	2 ¹¹	2 ¹⁰	2 ⁹	2 ⁸

default value 00h

● INTERRUPT (4Ah)

Field	Bit	TYPE	Description
PS INT STAUTS	7	R	0 : PS interrupt signal inactive 1 : PS interrupt signal active
ALS INT STATUS	6	R	0 : ALS interrupt signal inactive 1 : ALS interrupt signal active
INT MODE	5 : 4	RW	00 : Only PS_TH_H is effective 01 : PS_TH_H and PS_TH_L are effective as hysteresis 10 : PS_TH_H and PS_TH_L are effective as outside detection 11 : Forbidden
INT ASSERT	3	RW	0 : Interrupt output 'L' is stable if newer measurement result is also interrupt active 1 : Interrupt output 'L' is de-assert and re-assert if newer measurement result is also interrupt active
INT LATCH	2	RW	0 : INT pin is latched until INTERRUPT register is read or initialized 1 : INT pin is updated after each measurement
INT TRIG	1 : 0	RW	00 : INT pin is inactive 01 : Triggered by only PS measurement 10 : Triggered by only ALS measurement 11 : Triggered by PS and ALS measurement

default value 00h

1. In case of PS/ALS outside detection mode, interrupt signal inactive means that measurement result is within registered threshold level; interrupt signal active means measurement result is out of registered threshold level.
2. In case of PS hysteresis mode, once interrupt signal becomes active, INT status is kept until measurement result becomes less than PS_TH_L register value.
3. Persistence is for PS only.
4. INT Pin become inactive (high impedance) if INTERRUPT register is read, initialized, or SW reset is started.

● PS_TH_LSBs (4Bh)

Register	TYPE	7	6	5	4	3	2	1	0
PS_TH_LSBs	RW	2 ⁷	2 ⁶	2 ⁵	2 ⁴	2 ³	2 ²	2 ¹	2 ⁰

default value FFh

● PS_TH_MSBs (4Ch)

Register	TYPE	7	6	5	4	3	2	1	0
PS_TH_MSBs	RW	0	0	0	0	2 ¹¹	2 ¹⁰	2 ⁹	2 ⁸

default value 0Fh

● PS_TL_LSBs (4Dh)

Register	TYPE	7	6	5	4	3	2	1	0
PS_TL_LSBs	RW	2 ⁷	2 ⁶	2 ⁵	2 ⁴	2 ³	2 ²	2 ¹	2 ⁰

default value 00h

● PS_TL_MSBs (4Eh)

Register	TYPE	7	6	5	4	3	2	1	0
PS_TL_MSBs	RW	0	0	0	0	2 ¹¹	2 ¹⁰	2 ⁹	2 ⁸

default value 00h

● ALS_DATA0_TH_LSBs (4Fh)

Register	TYPE	7	6	5	4	3	2	1	0
ALS_DATA0_TH_LSBs	RW	2^7	2^6	2^5	2^4	2^3	2^2	2^1	2^0

default value FFh

● ALS_DATA0_TH_MSBs (50h)

Register	TYPE	7	6	5	4	3	2	1	0
ALS_DATA0_TH_MSBs	RW	2^{15}	2^{14}	2^{13}	2^{12}	2^{11}	2^{10}	2^9	2^8

default value FFh

● ALS_DATA0_TL_LSBs (51h)

Register	TYPE	7	6	5	4	3	2	1	0
ALS_DATA0_TL_LSBs	RW	2^7	2^6	2^5	2^4	2^3	2^2	2^1	2^0

default value 00h

● ALS_DATA0_TL_MSBs (52h)

Register	TYPE	7	6	5	4	3	2	1	0
ALS_DATA0_TL_MSBs	RW	2^{15}	2^{14}	2^{13}	2^{12}	2^{11}	2^{10}	2^9	2^8

default value 00h

● PS_OFFSET_LSBs (53h)

Register	TYPE	7	6	5	4	3	2	1	0
PS_OFFSET_LSBs	RW	2^7	2^6	2^5	2^4	2^3	2^2	2^1	2^0

default value 00h

● PS_OFFSET_MSBs (54h)

Field	Bit	TYPE	Description
Resereved	7 : 2	R	Ignored
PS_OFFSET_MSBs	1 : 0	RW	Shown below

default value 00h

Register	TYPE	7	6	5	4	3	2	1	0
PS_OFFSET_MSBs	RW	-	-	-	-	-	-	2^9	2^8

default value 00h

When changed these registers, PS_DATA (44h,45h) becomes
 ([PS measured value]- ([PS offset value]) offset value)

● MANUFACT_ID (92h)

Field	Bit	TYPE	Description
MANUFACT_ID	7 : 0	R	11100000

default value E0h

● I²C bus communication

1) Slave address "0111000" (38h)

2) Main write format

1. Case of "Indicating register address"

ST	Slave Address 0111000	W 0	ACK	Indicate register address 010XXXXX	ACK	SP
----	--------------------------	--------	-----	---------------------------------------	-----	----

2. Case of "writing data register after indicating register address"

ST	Slave Address 0111000	W 0	ACK	Indicate register address 010XXXXX	ACK
----	--------------------------	--------	-----	---------------------------------------	-----

Data specified at register address field	ACK	ACK	Data specified at register address field + N	ACK	SP
---	-----	-----	--	-----	----

RPR-0521RS continues to write data with address increments until master issues stop condition.
Write cycle is 40h - 41h - 42h - 43h - 44h - 45h - 46h 53h - 54h - 40h

Ex) If register address field is 42h, then RPR-0521RS writes data like below.

42h - 43h - 44h - 45h - 46h 53h - 54h - 40h.....

Register writing continues until master issues stop condition.

3) Main read format

1. Case of "Reading data after indicating register address" (Master issues restart condition)

ST	Slave Address 0111000	W 0	ACK	Indicate register address 010XXXXX	ACK
----	--------------------------	--------	-----	---------------------------------------	-----

ST	Slave Address 0111000	R 1	ACK	Data specified at register address field	ACK
----	--------------------------	--------	-----	---	-----

Data specified at register address field + 1	ACK	ACK	Data specified at register address field + N	NACK	SP
---	-----	-----	---	------	----

2. Case of "Reading data from specified register address"

ST	Slave Address 0111000	R 1	ACK	Data specified at register address field	ACK
----	--------------------------	--------	-----	---	-----

Data specified at register address field + 1	ACK	ACK	Data specified at register address field + N	NACK	SP
---	-----	-----	---	------	----

RPR-0521RS continues to read data from specified address field until master issues stop condition.

Read cycle is 40h - 41h - 42h - 43h - 44h - 45h - 46h 53h - 54h - 40h

Ex) If register address field is 53h, then RPR-0521RS reads data like below.

53h - 54h - 40h

Register reading continues until master issues stop condition.



from master to slave



from slave to master

※ RPR-0521RS operates as I2C bus slave device.

※ Please refer formality I2C bus specification of NXP semiconductors.

● Notice in case of using ALS 50ms measurement mode

At 50msec mode (MODE_CONTROL (41h) <3:0>:"1100"), full scale count of ALS_DATA0 (46h, 47h) and ALS_DATA1 (48h, 49h) become half of other modes.
ALS_DATA0<15> or ALS_DATA1<15> is a flag indicating the data overflow.
Consequently, additional function as follows is necessary in software at 50msec mode.

```
<Necessary software function>
if (DATA0<15>==1){DATA0<15:0>=7FFFh}
if (DATA1<15>==1){DATA1<15:0>=7FFFh}
```

*This function is necessary at 50msec mode only.

*This function must be executed before Lux calculation given

● PS twice measurement mode

RPR-0521RS has two PS operating modes that can be selected by MODE_CONTROL(41h).

At normal mode, PS measurement is done only once in each measurement period.

At twice measurement mode, PS measurement is done twice in each measurement period.

By using twice measurement mode, quicker response of interrupt is available than normal mode when persistence function is active.

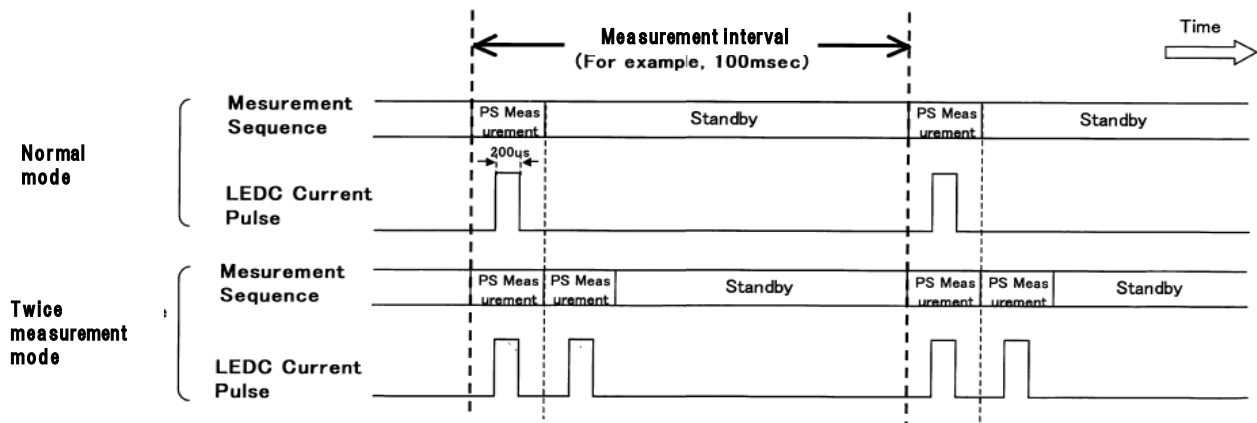

● Notice in case of changing register value

When master changes a value of ALS_PS_CONTROL(42h) (For example, ALS gain), it is necessary to stop the ALS/PS measurement in progress and re-start the measurement from the beginning (“Interrupt & Re-start” sequence). The way to “Interrupt & Re-start” is to write some data to MODE CONTROL(41h). By writing both MODE_CONTROL(41h) and ALS_PS_CONTROL(42h) with address increments access, it is possible to change the register setting and “Interrupt & Re-start” the measurement at the same time.

● Power on reset function

RPR-0521RS series have power on reset function. By operating this function, all of registers are reset when the power is supplied.

Please note followings and design the application.

① Power on time : t1

t1 > 2ms

RPR-0521RS series become operational after 2ms since VDD voltage crosses 2.0V from being less than 0.4V.

② Power off time : t2

t2 > 1ms

Before the power is supplied, VDD voltage should be less than 0.4V at least for 1ms.

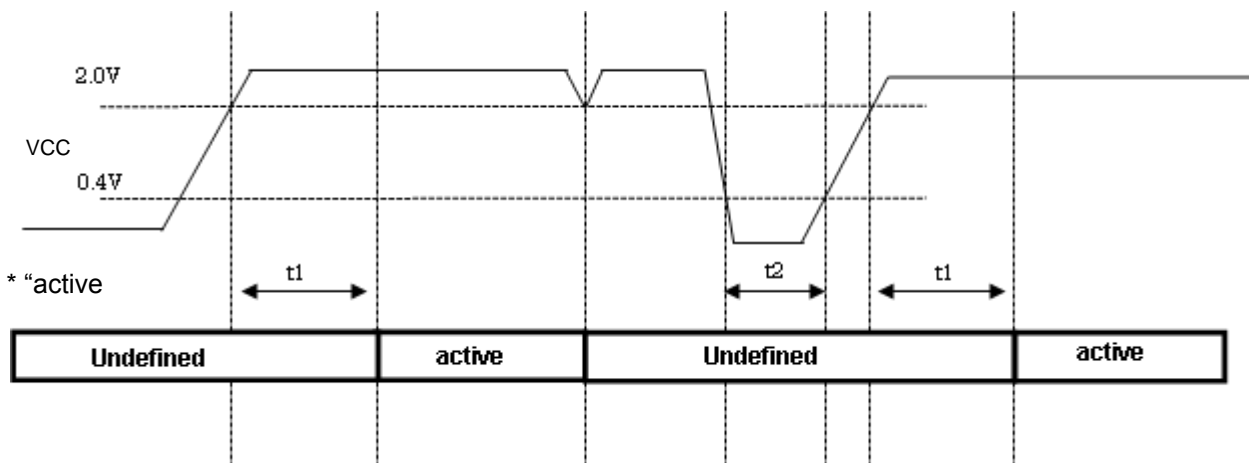

“active” means that RPR-0521RS series are correctly operational.

INT terminal is high impedance when VDD is supplied.

When VDD voltage become less than 2.0V, the power should be supplied again in accordance with the above sequence.

● Interrupt function

Interrupt function compares ALS and PS measurement result to preset interrupt threshold level. Interrupt status can be monitored by INT pin. Interrupt function is able to be controlled by INTTERRUPT register (4Ah).

Interrupt persistence is defined at PERSIST register (43h). Persistence function is for PS only. There are two output modes about interrupt function (latched mode and unlatched mode).

INT pin is Nch open drain terminal, so this terminal should be pull-up to some kind of voltage source by an external resistance. INT terminal is high impedance when VCC is supplied.

INT terminal keeps previous state when power down command is sent. So it is recommended to set INT terminal to high impedance before sending power down command. VDD current (approximately 25uA at VDD=2.5V) is consumed during INT terminal is active. INT terminal can be changed to high impedance by writing INT reset command, reading INTERRUPT register (4Ah), or resetting software.

ex1) In case of using PS 'H' threshold (INTERRUPT register 4Ah<5:4> : "00")

In case of unlatched mode, if the measurement value exceeds the PS interrupt threshold 'H' value, the interrupt becomes active. And if the measurement value is below the threshold 'H' value, the interrupt becomes inactive.

In case of latched mode, once the interrupt becomes active, it keeps the status until INT reset command is sent or interrupt register is read.

In case of persistence function is set to active, if the INT is inactive, it keeps inactive status until the measurement value exceeds the threshold 'H' value continuously. If the interrupt is active, it keeps active status until INT reset command is sent, interrupt register is read, or the measurement value is below threshold 'H' value continuously (case of unlatched mode).

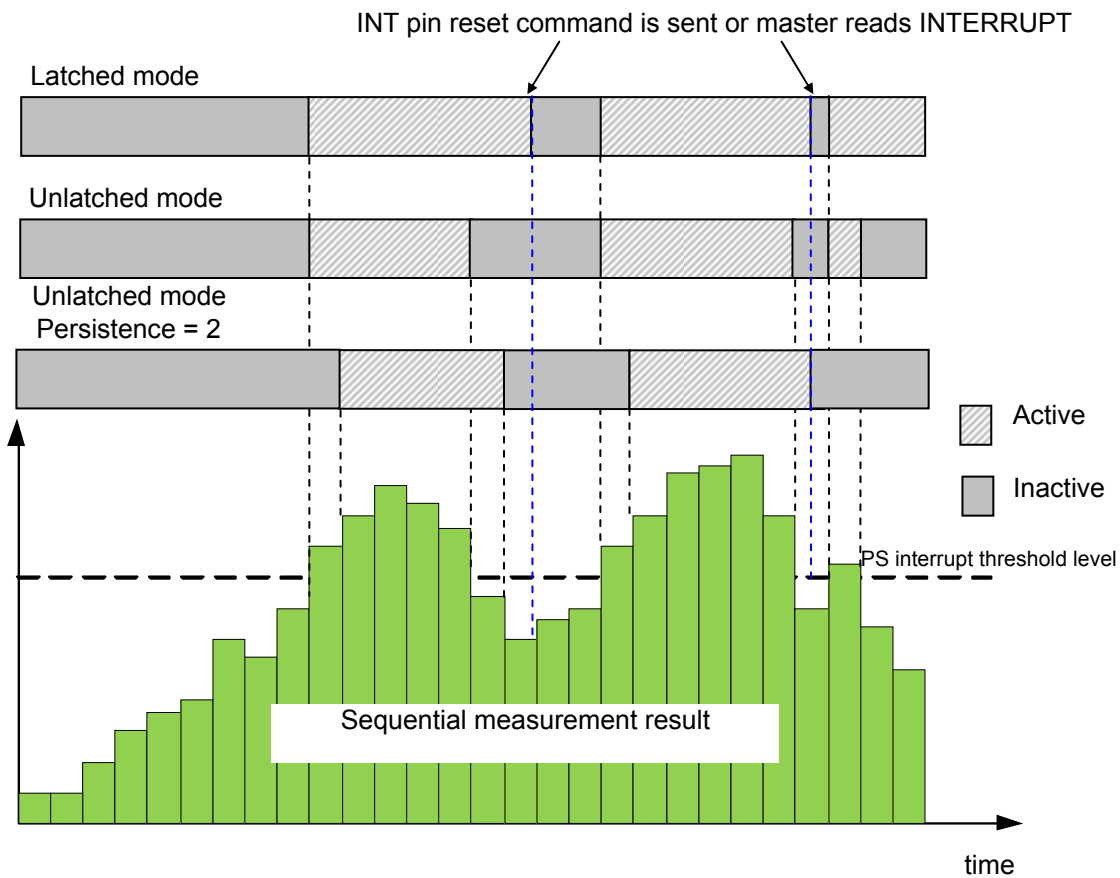

ex2) In case of using PS hysteresis mode (INTERRUPT register 4Ah<5:4> : " 01")

In case of unlatched mode, if the measurement value exceeds the PS interrupt threshold 'H' value, the interrupt becomes active. And if the measurement value is below the threshold 'L' value, the interrupt becomes inactive.
 In case of latched mode, once the interrupt becomes active, it keeps the status until INT reset command is sent or interrupt register is read.

In case of persistence function is set to active, if the INT is inactive, it keeps inactive status until the measurement value exceeds the threshold 'H' value continuously. If the interrupt is active, it keeps active status until INT reset command is sent, interrupt register is read, or the measurement value is below threshold 'L' value continuously.

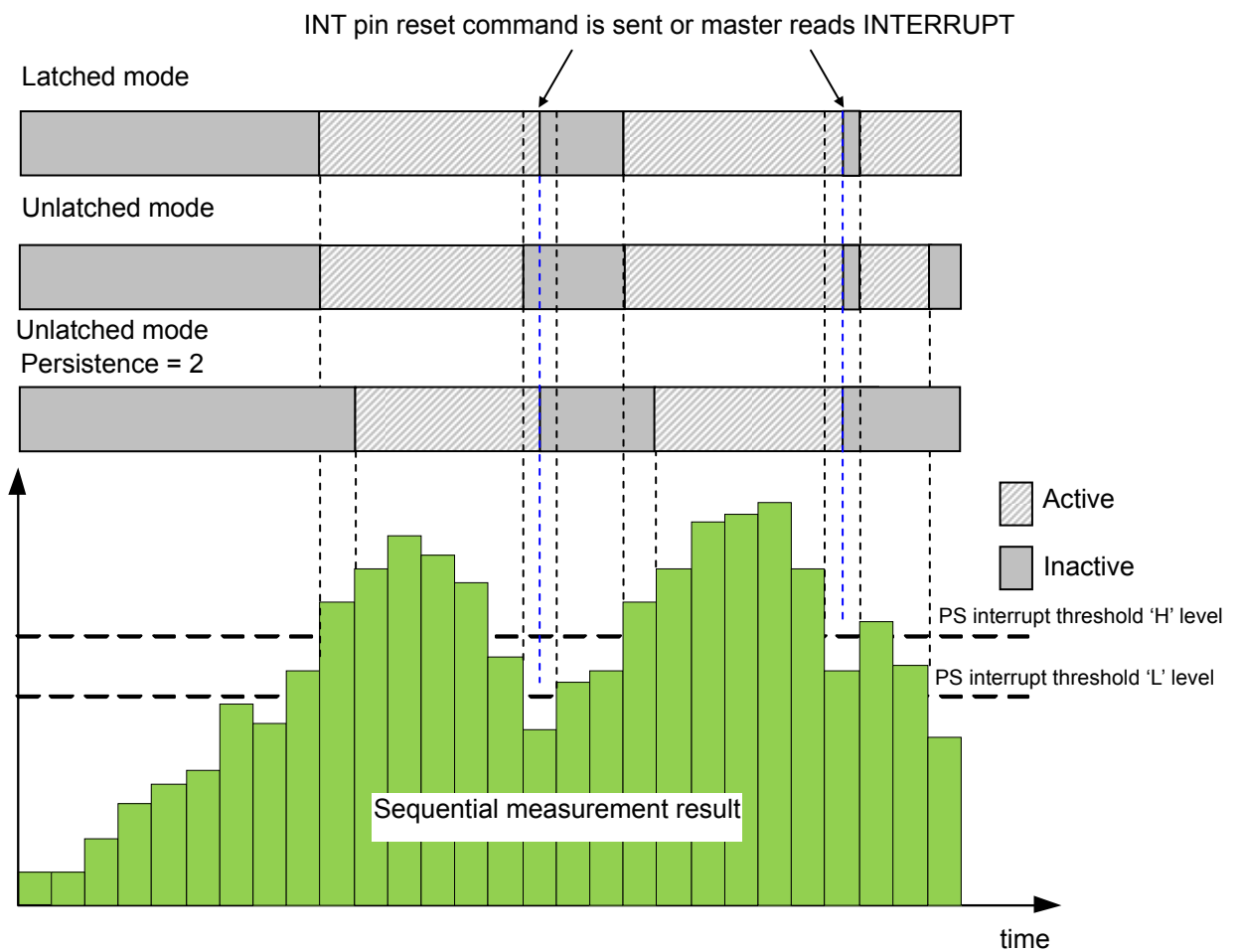

ex3) In case of using PS outside threshold mode (INTERRUPT register 4Ah<5:4> : " 10")

In case of unlatched mode, if the measurement value is within the range set by PS interrupt threshold 'H' and 'L' value, the interrupt becomes inactive. And if the measurement value is out of the range set by threshold 'H' and 'L' value, the interrupt becomes active.

In case of latched mode, once the interrupt becomes active, it keeps active status until INT reset command is sent, or interrupt register is read.

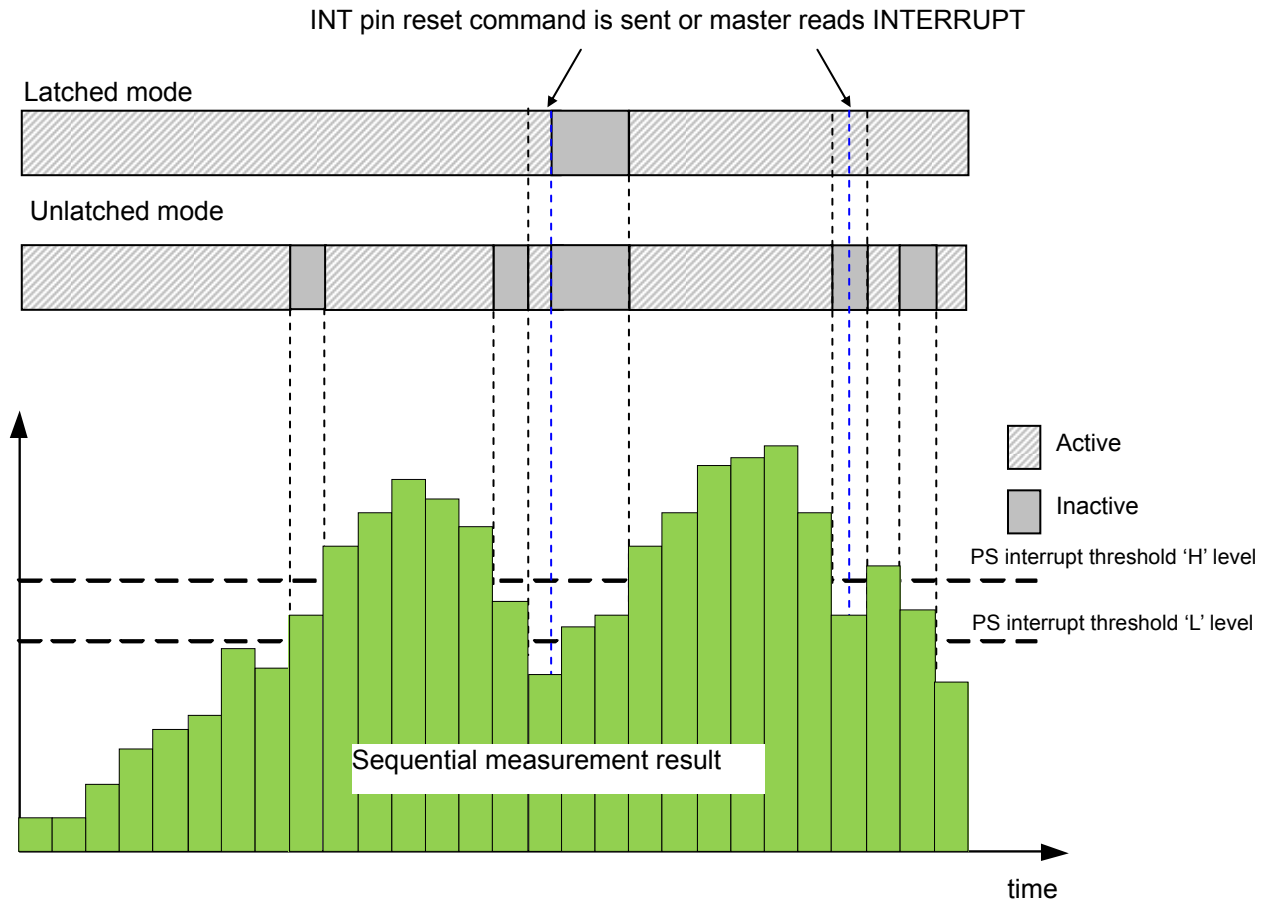

ex4) Ambient light sensor interrupt function

In case of unlatched mode, if the measurement value (ALS_DATA0) is within the range set by ALS interrupt threshold 'H' and 'L' value, the interrupt becomes inactive. And if the measurement value (ALS_DATA0) is out of the range set by threshold 'H' and 'L' value, the interrupt becomes active.

In case of latched mode, once the interrupt becomes active, it keeps active status until INT reset command is sent, or interrupt register is read.

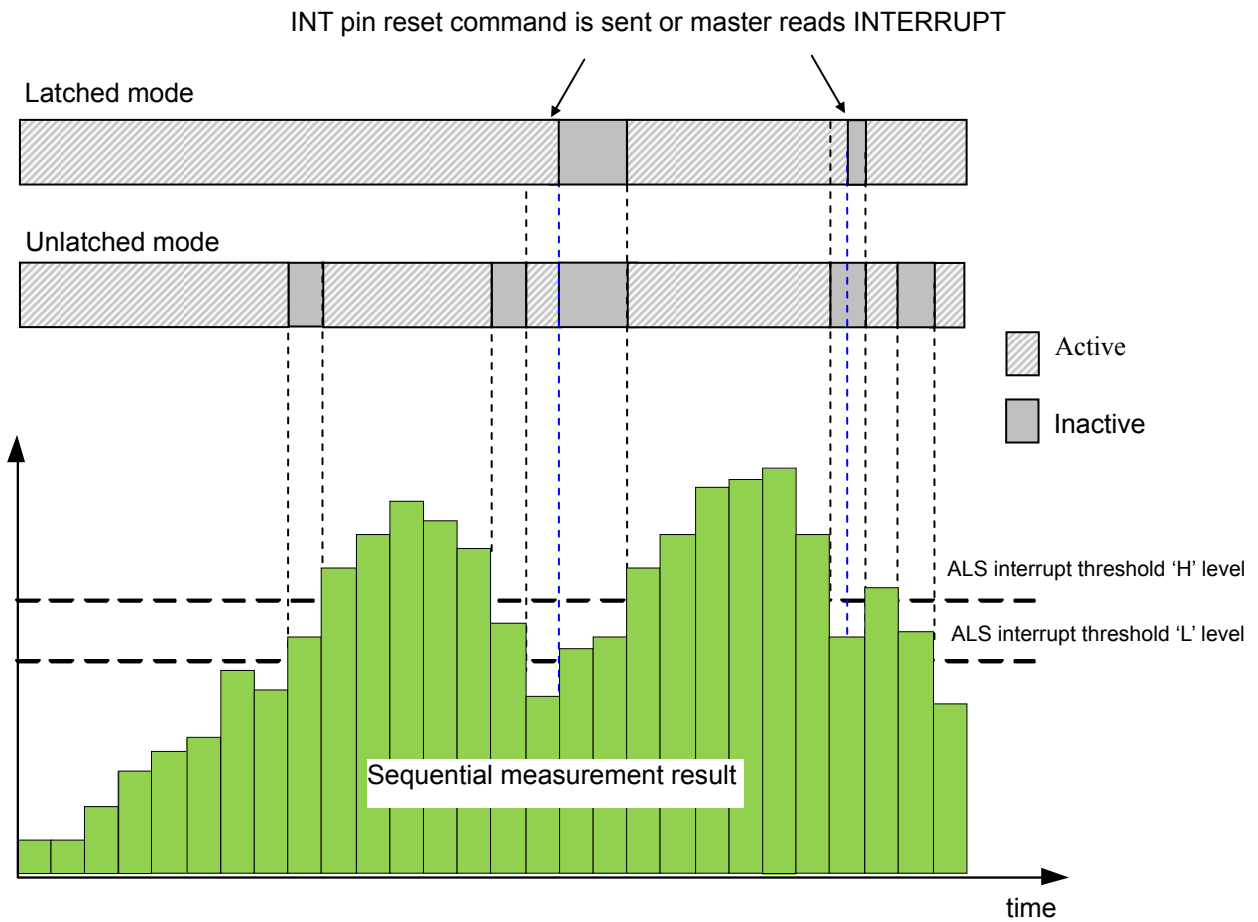

- Cautions for using this product

- 1) Absolute Maximum Ratings

An excess in the absolute maximum ratings, such as supply voltage, temperature range of operating conditions (T_{opr}), etc., can break down devices, and make impossible to identify breaking mode such as short circuit or open circuit. If any special mode exceeding the absolute maximum ratings is assumed, consideration should be given to take physical safety measures including the use of fuses.

- 2) GND voltage

It is necessary to keep the potential of the GND terminal at the minimum potential of all terminals at any time.

- 3) Short circuit between terminals and erroneous mounting

In order to mount products on the set PCB, pay thorough attention to the direction and offset of the products. Erroneous mounting can break down the products. Furthermore, if a short circuit occurs due to foreign matters entering between terminals or between the terminal and the power supply or the GND terminal, the products can break down.

- 4) Operation in strong electromagnetic field

Be noted that using products in the strong electromagnetic field can malfunction.

- 5) Inspection with set PCB

In order to mount or dismount the set PCB to/from the jig for the inspection process, be sure to turn OFF the power supply. In addition, pay attention to protection against static electricity.

- 6) Dust or scratch

Dusts or scratch on the photo detector may affect the optical characteristics. Please handle it with care.

- 7) Rush current

When power is supplied to the product, it is possible that the internal logic may be unstable and rush current may flow instantaneously. Therefore, give special consideration to power coupling capacitance, power supply, and circuit design.

Notes

- 1) The information contained herein is subject to change without notice.
- 2) Before you use our Products, please contact our sales representative and verify the latest specifications :
- 3) Although ROHM is continuously working to improve product reliability and quality, semiconductors can break down and malfunction due to various factors.
Therefore, in order to prevent personal injury or fire arising from failure, please take safety measures such as complying with the derating characteristics, implementing redundant and fire prevention designs, and utilizing backups and fail-safe procedures. ROHM shall have no responsibility for any damages arising out of the use of our Products beyond the rating specified by ROHM.
- 4) Examples of application circuits, circuit constants and any other information contained herein are provided only to illustrate the standard usage and operations of the Products. The peripheral conditions must be taken into account when designing circuits for mass production.
- 5) The technical information specified herein is intended only to show the typical functions of and examples of application circuits for the Products. ROHM does not grant you, explicitly or implicitly, any license to use or exercise intellectual property or other rights held by ROHM or any other parties. ROHM shall have no responsibility whatsoever for any dispute arising out of the use of such technical information.
- 6) The Products are intended for use in general electronic equipment (i.e. AV/OA devices, communication, consumer systems, gaming/entertainment sets) as well as the applications indicated in this document.
- 7) The Products specified in this document are not designed to be radiation tolerant.
- 8) For use of our Products in applications requiring a high degree of reliability (as exemplified below), please contact and consult with a ROHM representative : transportation equipment (i.e. cars, ships, trains), primary communication equipment, traffic lights, fire/crime prevention, safety equipment, medical systems, servers, solar cells, and power transmission systems.
- 9) Do not use our Products in applications requiring extremely high reliability, such as aerospace equipment, nuclear power control systems, and submarine repeaters.
- 10) ROHM shall have no responsibility for any damages or injury arising from non-compliance with the recommended usage conditions and specifications contained herein.
- 11) ROHM has used reasonable care to ensure the accuracy of the information contained in this document. However, ROHM does not warrants that such information is error-free, and ROHM shall have no responsibility for any damages arising from any inaccuracy or misprint of such information.
- 12) Please use the Products in accordance with any applicable environmental laws and regulations, such as the RoHS Directive. For more details, including RoHS compatibility, please contact a ROHM sales office. ROHM shall have no responsibility for any damages or losses resulting non-compliance with any applicable laws or regulations.
- 13) When providing our Products and technologies contained in this document to other countries, you must abide by the procedures and provisions stipulated in all applicable export laws and regulations, including without limitation the US Export Administration Regulations and the Foreign Exchange and Foreign Trade Act.
- 14) This document, in part or in whole, may not be reprinted or reproduced without prior consent of ROHM.



Thank you for your accessing to ROHM product informations.
More detail product informations and catalogs are available, please contact us.

ROHM Customer Support System

<http://www.rohm.com/contact/>



Компания «ЭлектроПласт» предлагает заключение долгосрочных отношений при поставках импортных электронных компонентов на взаимовыгодных условиях!

Наши преимущества:

- Оперативные поставки широкого спектра электронных компонентов отечественного и импортного производства напрямую от производителей и с крупнейших мировых складов;
- Поставка более 17-ти миллионов наименований электронных компонентов;
- Поставка сложных, дефицитных, либо снятых с производства позиций;
- Оперативные сроки поставки под заказ (от 5 рабочих дней);
- Экспресс доставка в любую точку России;
- Техническая поддержка проекта, помощь в подборе аналогов, поставка прототипов;
- Система менеджмента качества сертифицирована по Международному стандарту ISO 9001;
- Лицензия ФСБ на осуществление работ с использованием сведений, составляющих государственную тайну;
- Поставка специализированных компонентов (Xilinx, Altera, Analog Devices, Intersil, Interpoint, Microsemi, Aeroflex, Peregrine, Syfer, Eurofarad, Texas Instrument, Miteq, Cobham, E2V, MA-COM, Hittite, Mini-Circuits, General Dynamics и др.);

Помимо этого, одним из направлений компании «ЭлектроПласт» является направление «Источники питания». Мы предлагаем Вам помощь Конструкторского отдела:

- Подбор оптимального решения, техническое обоснование при выборе компонента;
- Подбор аналогов;
- Консультации по применению компонента;
- Поставка образцов и прототипов;
- Техническая поддержка проекта;
- Защита от снятия компонента с производства.



Как с нами связаться

Телефон: 8 (812) 309 58 32 (многоканальный)

Факс: 8 (812) 320-02-42

Электронная почта: org@eplast1.ru

Адрес: 198099, г. Санкт-Петербург, ул. Калинина, дом 2, корпус 4, литера А.