



**KH3 Series
Receiver Module
Data Guide**

Wireless made simple[®]

Warning: Some customers may want Linx radio frequency (“RF”) products to control machinery or devices remotely, including machinery or devices that can cause death, bodily injuries, and/or property damage if improperly or inadvertently triggered, particularly in industrial settings or other applications implicating life-safety concerns (“Life and Property Safety Situations”).

NO OEM LINX REMOTE CONTROL OR FUNCTION MODULE SHOULD EVER BE USED IN LIFE AND PROPERTY SAFETY SITUATIONS. No OEM Linx Remote Control or Function Module should be modified for Life and Property Safety Situations. Such modification cannot provide sufficient safety and will void the product’s regulatory certification and warranty.

Customers may use our (non-Function) Modules, Antenna and Connectors as part of other systems in Life Safety Situations, but only with necessary and industry appropriate redundancies and in compliance with applicable safety standards, including without limitation, ANSI and NFPA standards. It is solely the responsibility of any Linx customer who uses one or more of these products to incorporate appropriate redundancies and safety standards for the Life and Property Safety Situation application.

Do not use this or any Linx product to trigger an action directly from the data line or RSSI lines without a protocol or encoder/decoder to validate the data. Without validation, any signal from another unrelated transmitter in the environment received by the module could inadvertently trigger the action.

All RF products are susceptible to RF interference that can prevent communication. RF products without frequency agility or hopping implemented are more subject to interference. This module does not have a frequency hopping protocol built in.

Do not use any Linx product over the limits in this data guide. Excessive voltage or extended operation at the maximum voltage could cause product failure. Exceeding the reflow temperature profile could cause product failure which is not immediately evident.

Do not make any physical or electrical modifications to any Linx product. This will void the warranty and regulatory and UL certifications and may cause product failure which is not immediately evident.

Table of Contents

1	Description
1	Features
1	Applications
2	Ordering Information
2	Absolute Maximum Ratings
3	Electrical Specifications
5	Typical Performance Graphs
6	Pin Assignments
7	Pin Descriptions
8	Module Description
8	Theory of Operation
9	Decoder Operation
10	Compatibility with the KH2 Series
10	Setting the Receiver Address
10	The Data Line Outputs
11	Receiving Data
11	Using the RSSI Line
12	Input Type Selection
13	Power Supply Requirements
14	Typical Applications
16	Antenna Considerations
17	Helpful Application Notes from Linx
18	Interference Considerations
19	Pad Layout
19	Board Layout Guidelines
21	Microstrip Details
22	Production Guidelines
22	Hand Assembly
22	Automated Assembly

- 24 General Antenna Rules
- 26 Common Antenna Styles
- 28 Regulatory Considerations
- 30 Notes

KH3 Series Receiver Module

Data Guide



Description

The KH3 Series is ideally suited for volume use in OEM applications such as remote control / command and keyless entry. It combines a high-performance RF receiver with an on-board decoder. When paired with a matching KH3 Series transmitter / encoder module, OEM transmitter, or LC or LR Series transmitter and DS Series encoder combination, a highly reliable

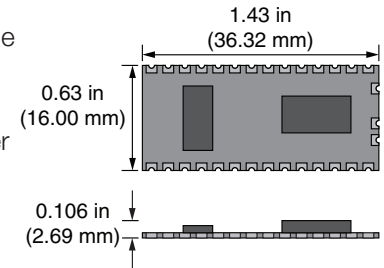

Figure 1: Package Dimensions

wireless link is formed that is capable of transferring the status of eight parallel inputs for distances of up to 3,000 feet (1,000m). Ten address lines provide 1,022 ($2^{10}-2$) different addresses for security and uniqueness. Housed in a compact SMD package, the KH3 module utilizes an advanced synthesized architecture to achieve an unmatched blend of performance, size, range and cost. No external RF components are required except an antenna, making design integration straightforward.

Features

- Low cost
- Received data output
- Long range
- Transmission validation
- On-board encoder
- No production tuning
- 8 parallel binary inputs
- No external RF components required (except an antenna)
- 2^{10} addresses for uniqueness
- Pin-compatible with original KH and KH2 modules
- Ultra-low power consumption
- Advanced synthesized architecture
- Compact SMD package

Applications

- Remote control / command
- Remote status monitoring
- Gate openers
- Home / industrial automation
- Lighting control
- Wire elimination
- Call systems

Ordering Information

Ordering Information	
Part Number	Description
TXM-315-KH3	315MHz Transmitter / Encoder
TXM-418-KH3	418MHz Transmitter / Encoder
TXM-433-KH3	433MHz Transmitter / Encoder
RXM-315-KH3	315MHz Receiver / Decoder
RXM-418-KH3	418MHz Receiver / Decoder
RXM-433-KH3	433MHz Receiver / Decoder
EVAL-***-KH3	KH3 Series Basic Evaluation Kit

*** = 315, 418 (Standard), 433MHz
Receivers are supplied in tubes of 20 pcs.

Figure 2: Ordering Information

Absolute Maximum Ratings

Absolute Maximum Ratings				
Supply Voltage V_{CC}	-0.3	to	+3.6	VDC
Any Input or Output Pin	-0.3	to	+3.6	VDC
RF Input		0		dBm
Operating Temperature	-40	to	+70	°C
Storage Temperature	-55	to	+85	°C
Soldering Temperature	+255°C for 10 seconds			

Exceeding any of the limits of this section may lead to permanent damage to the device. Furthermore, extended operation at these maximum ratings may reduce the life of this device.

Figure 3: Absolute Maximum Ratings

 **Warning:** This product incorporates numerous static-sensitive components. Always wear an ESD wrist strap and observe proper ESD handling procedures when working with this device. Failure to observe this precaution may result in module damage or failure.

Electrical Specifications

KH3 Series Receiver Specifications						
Parameter	Symbol	Min.	Typ.	Max.	Units	Notes
Power Supply						
Operating Voltage	V_{CC}	2.7	3.0	3.6	VDC	
With Dropping Resistor				5.2	VDC	1,4
Supply Current	I_{CC}	4.0	5.9	7.0	mA	7
Power Down Current	I_{PDN}		47	57	μA	4
Receiver Section						
Receive Frequency Range	F_C					
RXM-315-KH3			315		MHz	
RXM-418-KH3			418		MHz	
RXM-433-KH3			433.92		MHz	
Center Frequency Accuracy		-50		+50	kHz	
LO Feedthrough			-80		dBm	2,4
IF Frequency	F_{IF}		10.7		MHz	5
Noise Bandwidth	N_{3dB}		280		kHz	
Data Rate		100		10,000	bps	
Data Output						
Logic Low	V_{OL}		0.0		VDC	3
Logic High	V_{OH}		3.0		VDC	3
Power-Down Input						
Logic Low	V_{IL}			0.4	VDC	
Logic High	V_{IH}	$V_{CC}-0.4$			VDC	
Receiver Sensitivity		-106	-112	-118	dBm	
RSSI / Analog						
Dynamic Range			80		dB	4
Analog Bandwidth		50		5,000	Hz	4
Gain			16		mV/dB	4
Voltage With No Carrier			1.5		V	4
Antenna Port						
RF Input Impedance	R_{IN}		50		Ω	4
Timing						
Receiver Turn-On Time						
Via V_{CC}		3.0	7.0	10.0	ms	4,5
Via PDN		0.04	0.25	0.50	ms	4,5

KH2 Series Receiver Specifications Continued

Parameter	Symbol	Min.	Typ.	Max.	Units	Notes
Decoder Section						
TX Data Length			26 bits 3x			
Average Data Duty Cycle			50%			
Output Drive Current		0.6	1.0	1.2	mA	6
Environmental						
Operating Temperature Range		-40		+70	°C	4

1. The KH3 can utilize up to a 5.2VDC supply provided a dropping resistor is placed in series with V_{CC} . However, it is recommended to use a 3.0 - 3.3V supply.
2. Into a 50Ω load
3. When operating from a 5V source, it is important to consider that the output will swing to well less than 5 volts as a result of the required dropping resistor. Please verify that the minimum voltage will meet the high threshold requirement of the device to which data is being sent.
4. Characterized, but not tested
5. Time to valid data output
6. Maximum drive capability of data outputs
7. At 25°C

Figure 4: Electrical Specifications

Typical Performance Graphs

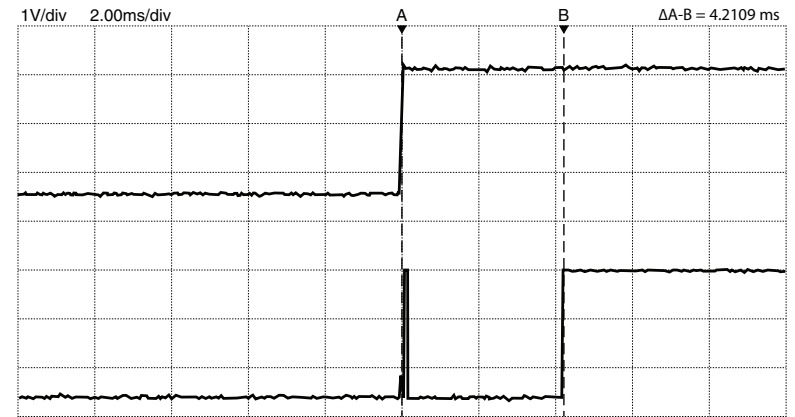

Figure 5: KH3 Series Receiver Turn-On Time from V_{CC}

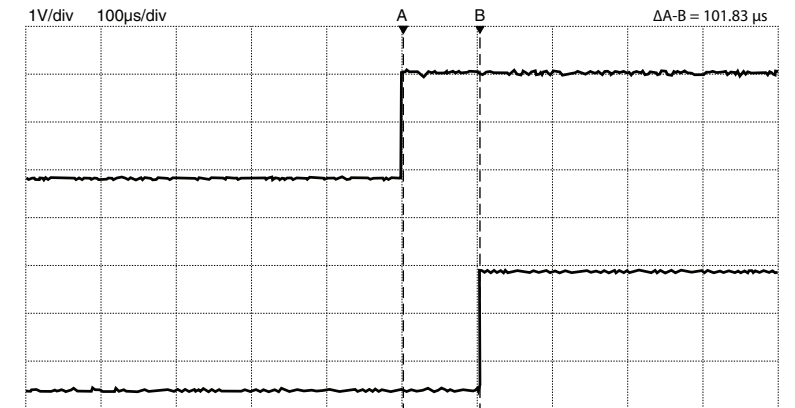

Figure 6: KH3 Series Receiver Turn-On Time from PDN

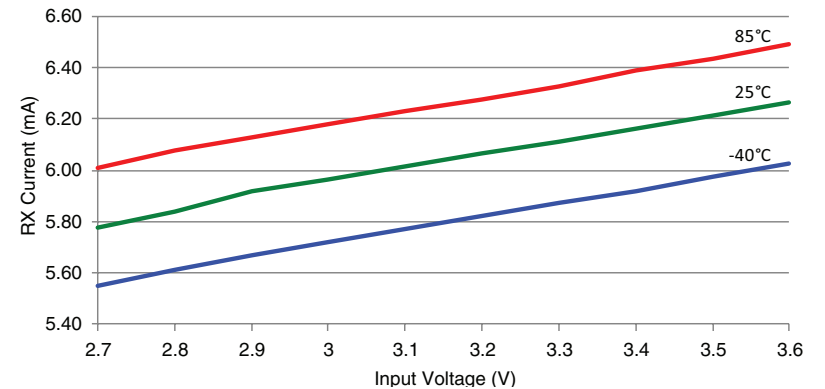

Figure 7: KH3 Series Receiver Current Consumption vs. Supply Voltage

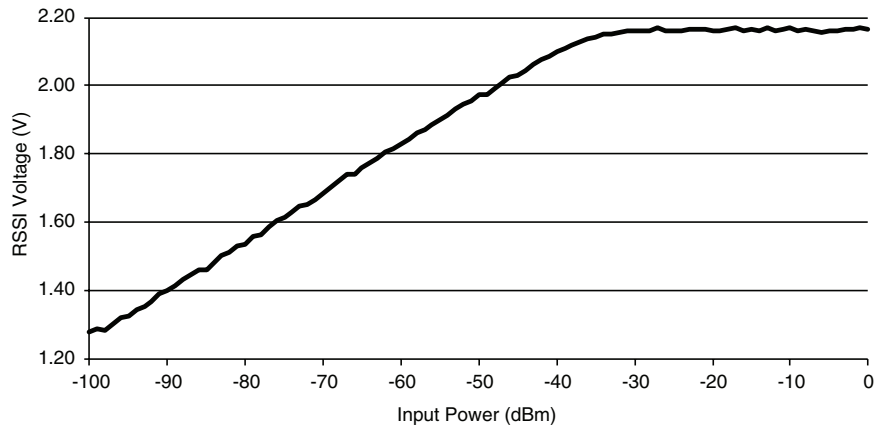

Figure 8: KH3 Series Receiver RSSI Response Time

Pin Assignments

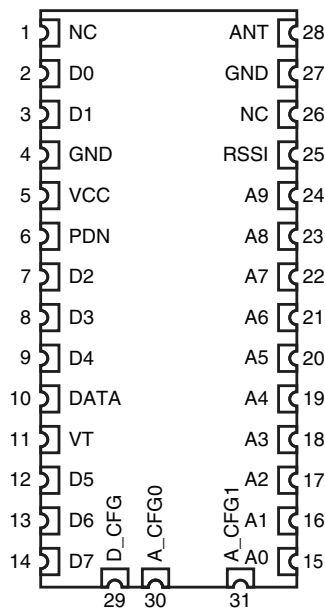

Figure 9: KH3 Series Receiver Pinout (Top View)

Pin Descriptions

Pin Descriptions			
Pin Number	Name	I/O	Description
1	NC	—	No Connection. For physical support only.
2, 3, 7, 8, 9, 12, 13, 14	D0–D7	O	Data Output Lines. Upon a valid transmission, these lines are set to replicate the state of the transmitter's data lines.
4	GND	—	Analog Ground
5	V _{CC}	—	Supply Voltage
6	PDN	I	Power Down. Pulling this line low places the receiver into a low-current state. The module is not able to receive a signal in this state.
10	DATA	O	Data output of the receiver prior to the decoder.
11	VT	O	Valid Transmission. This line goes high when a valid transmission is received.
15–24	A0–A9	I	Address Lines. The state of these lines must match the state of the transmitter's address lines in order for a transmission to be accepted. These lines are pulled to V _{CC} internally.
25	RSSI	O	Received Signal Strength Indicator. This line outputs an analog voltage that is proportional to the strength of the received signal.
26	NC	—	No Connection. For physical support only.
27	GND	—	Analog Ground
28	RF IN	I	50-ohm RF Input
29	D_CFG	I	Data Line Configuration. Determines whether a low on a data line is interpreted as a zero bit or an open bit. See the Input Type Selection section. This line is pulled to GND internally.
30, 31	A_CFG0	I	Address Configuration 0. With A_CFG1, determines the address bit type interpretation. See the Input Type Selection section. This line is pulled to GND internally.
31	A_CFG1	I	Address Configuration 1. With A_CFG0, determines the address bit type interpretation. See the Input Type Selection section. This line is pulled to V _{CC} internally.

Figure 10: KH3 Series Receiver Pin Descriptions

Module Description

The KH3 Series module combines the popular Linx LR Series receiver with a decoder IC in a convenient SMD package. The module is ideal for general-purpose remote control and command applications. When paired with a matching Linx KH3 Series transmitter / encoder, OEM transmitter, LC, or LR Series transmitter and DS Series encoder combination, a highly reliable RF link is formed, capable of transferring control and command data over line-of-sight distances in excess of 3,000 feet. The on-board receiver / decoder combination provides eight switched outputs that correspond to the state of the data lines on the transmitter's encoder. Ten address lines are also provided to allow up to 1,022 ($2^{10} - 2$) unique identification codes.

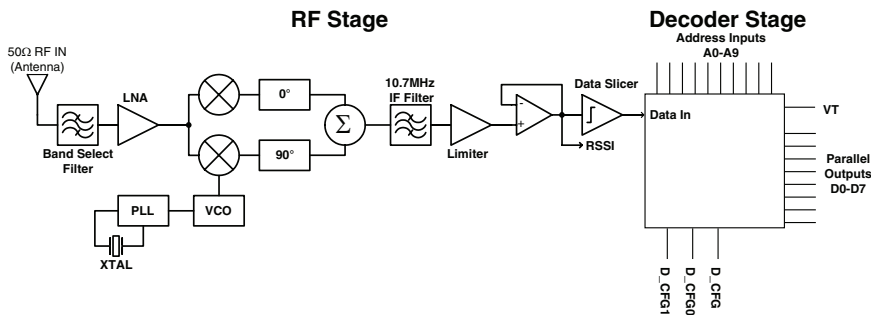

Figure 11: KH3 Series Receiver Block Diagram

Theory of Operation

The KH3 Series receiver module is designed to receive transmissions from a matching KH3 Series transmitter module or other compatible Linx transmitter product. When transmitted data is received, the data is presented to the onboard decoder. If the incoming address matches the local address settings, the decoder's outputs are set to replicate the states of the transmitter's data lines.

The RF section of the KH3 module utilizes the LR Series receiver, which is an advanced single-conversion superhet design with a synthesized architecture, high IF frequency, and multilayer ceramic filters. The exceptional accuracy of the crystal-based synthesized architecture in the KH3 receiver module allows the receiver's pass band to be quite narrow, thus increasing sensitivity and reducing susceptibility to near-band interference.

Decoder Operation

The KH3 Series receiver utilizes the DS Series decoder. When the decoder receives data, it compares the address in the received packet to its local address lines. If the addresses match, then the data is stored and a second packet is received. The decoder compares the two packets to each other. If the packets match, then the received data bits are output on the data lines and the VT line is pulled high. It then looks for the next packet.

Once no valid data is received (there is a mismatch of address, of data, or of bit timings), the data and VT lines are pulled low and the decoder goes to sleep until more data is received.

The decoder compares two packets and, if they match, sets the outputs. If a data line is toggled during a transmission (for example D1 is activated while D0 is already activated) then the received packet will not match the previous packet and the output lines will be pulled low until the next packet arrives. This causes all of the outputs to briefly cut out when a line is toggled.

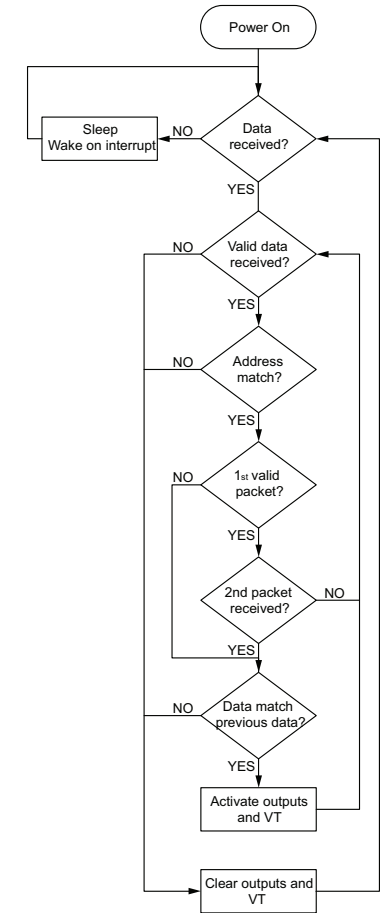

Figure 12: KH3 Series Receiver / Decoder Flowchart

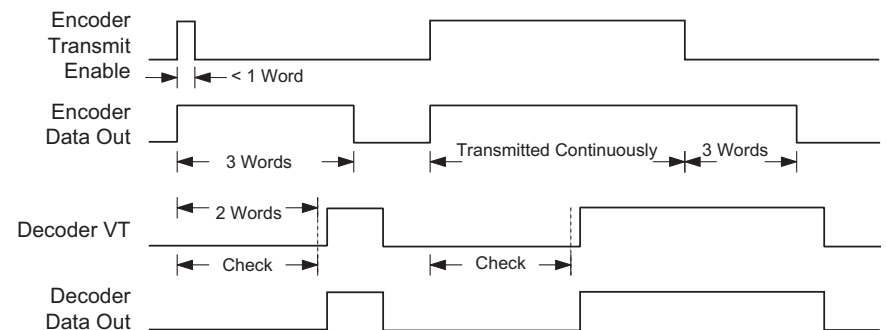

Figure 13: Encoder / Decoder Timing Diagram

Compatibility with the KH2 Series

The Legacy KH2 Series used encoders and decoders from Holtek® and the KH3 migrates to the Linx DS Series encoder and decoder. The protocol and functionality are compatible. There is some difference in the hardware set-up for the address lines and the data lines. The legacy Holtek® products used tri-state lines, so high, low and floating were each valid states. The DS Series has bi-state lines; high and low only. Three lines have been added to the KH3 module to allow for the selection of how the address and data line states are interpreted. Please see the Input Type Selection section for more details.

The KH3 receiver has been designed to be compatible with legacy systems. The module has been configured for the most common use of the KH2 so that it can be placed on existing boards without modification. This makes the KH3 a drop-in replacement for most applications.

Setting the Receiver Address

The module has ten address lines. This allows the formation of up to 1,022 ($2^{10} - 2$) unique transmitter-receiver relationships.

Note: All address lines high or all low is not allowed, so at least one line must be different from the others.

Because the address inputs have internal pull-up resistors these pins can be left floating or tied to GND. These pins may be hardwired or configured via a microprocessor, DIP switch or jumpers. The receiver's address line states must match the transmitter's exactly for a transmission to be recognized. If the transmitted address does not match the receiver's local address, then the receiver takes no action.

The Data Line Outputs

When data is received and the incoming address data matches the local address settings, the module's eight data output lines are set to replicate the state of the transmitter's data lines. In addition, the valid transmission line (VT, Pin 11) goes high to indicate reception and decoding of the data. The output have a drive level suitable for powering small LEDs and similar circuits, but anything more than 10mA should be buffered.

Receiving Data

Although the internal decoder handles all of the decoding and output for transmissions from a KH3 Series transmitter or an OEM transmitter, the KH3 Series receiver outputs the raw received data on the DATA line. The output of this line is the actual received data stream from the receiver and is always active regardless of address line status. It is made available for troubleshooting or monitoring internal data flow. It can also be used in mixed-mode systems where data may come from another source in addition to a KH3 Series transmitter module. This data can then be channeled to an external processor for decoding.

When using the KH3 for custom data transmissions, it is up to the designer to implement a noise-tolerant protocol to ensure the integrity of the data. Application Note AN-00160 provides some suggestions and guidelines.

The KH3 Series receiver module contains the LR Series receiver, which has a CMOS-compatible output capable of directly driving a microprocessor, an RS-232 level converter, or a Linx QS Series USB module. The LR Series receiver manual can be consulted for more details on the operation of the receiver itself.

Using the RSSI Line

The receiver's Received Signal Strength Indicator (RSSI) line serves a variety of functions. This line has a dynamic range of 80dB (typical) and outputs a voltage proportional to the incoming signal strength. It should be noted that the RSSI levels and dynamic range vary slightly from part to part. It is also important to remember that the RSSI output indicates the strength of any in-band RF energy and not necessarily just that from the intended transmitter; therefore, it should be used only to qualify the level and presence of a signal.

The RSSI output can be utilized during testing or even as a product feature to assess interference and channel quality by looking at the RSSI level with all intended transmitters shut off. The RSSI output can also be used in direction-finding applications, although there are many potential perils to consider in such systems. Finally, it can be used to save system power by "waking up" external circuitry when a transmission is received or crosses a certain threshold. The RSSI output feature adds tremendous versatility for the creative designer.

Input Type Selection

The KH3 Series receiver incorporates the DS Series remote control decoder, which is designed to be operable with previous generation products based on Holtek® encoders and decoders. The Holtek® encoders and decoders have tri-state input lines but the DS has bi-state lines.

Tri-state inputs are connected to ground for zero bits, V_{CC} for one bits, or left unconnected for open bits. Since the DS cannot match this operation the D_CFG, A_CFG0 and A_CFG1 lines are provided to select the desired interpretation. The settings must match on both ends.

Pulling the D_CFG line high configures the data bits as one and zero. A high on a data line on the transmitter is interpreted as a one bit and a low on the line is interpreted as a zero bit. Pulling D_CFG low configures the data bits as one and open. A high on a data line is interpreted as a one bit and a low on the line is interpreted as an open bit. The decoder outputs open data bits as logic low. This is shown in Figure 14.

D_CFG Configuration			
Configuration	Bit Interpretation		
	D_CFG	High	Low
0	One	Open	
1	One	Zero	

Figure 14: D_CFG Configuration

A_CFG0 and A_CFG1 are used to select the bit type for the address lines. These are shown in Figure 15.

A_CFG0 and A_CFG1 Configuration			
Configuration		Bit Interpretation	
A_CFG1	A_CFG0	High	Low
0	0	One	Zero
0	1	One	Open
1	0	Open	Zero
1	1	One	Zero

Figure 15: A_CFG0 and A_CFG1 Configuration

D_CFG is pulled low internally so that a high on a data line is transmitted as a one bit and a low on the line is transmitted as an open bit. A_CFG0 is pulled low and A_CFG1 is pulled high internally so that a high on an address line is interpreted as an open bit and a low as a zero bit.

This configuration matches the Linx OEM products and the most common implementation of the legacy KH2 Series. This enables customers using the KH2 Series to populate the KH3 Series without any PCB modifications since pins 25, 26 and 27 can be left unconnected.

Power Supply Requirements

The module does not have an internal voltage regulator; therefore it requires a clean, well-regulated power source. While it is preferable to power the unit from a battery, it can also be operated from a power supply as long as noise is less than 20mV. Power supply noise can affect the receiver sensitivity; therefore, providing a clean power supply for the module should be a high priority during design.

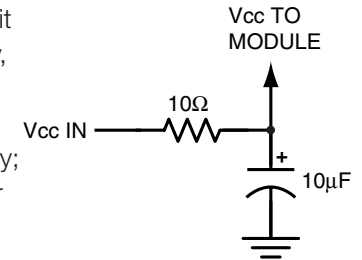

Figure 16: Power Supply Filter

A 10-ohm resistor in series with the supply followed by a 10μF tantalum capacitor from V_{CC} to ground will help in cases where the quality of supply power is poor. These values may need to be adjusted depending on the noise present on the supply line. Note that operation up to 5.2 volts requires the use of an external resistor placed in series with the supply to prevent V_{CC} from exceeding 3.6 volts, this dropping resistor can take the place of the 10-ohm resistor in the supply filter.

Typical Applications

Figure 17 shows an example of a basic remote control transmitter utilizing the KH3 Series receiver.

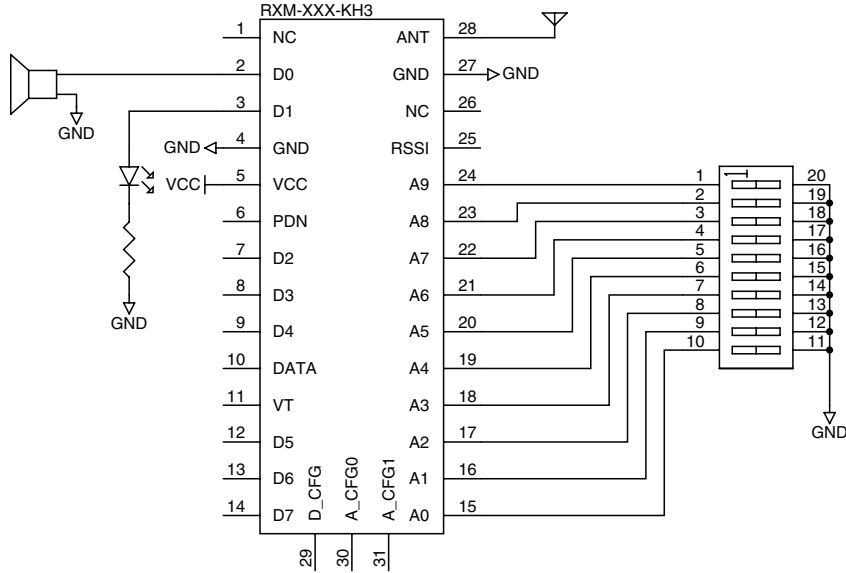

Figure 17: KH3 Series Receiver Typical Application Circuit

The data line outputs are used to drive external circuitry required by the application. In this example, when line D0 is activated on the transmitter line D0 on the receiver goes high and activates a buzzer. Likewise line D1 is used to activate an LED. The rest of the lines are not used in this example.

A ten-position DIP switch is used to set the address to either ground or V_{CC} . Since the address lines are internally pulled up to V_{CC} , no pull-up resistors are needed.

The KH3 Series receiver / decoder module is also suitable for use with Linx OEM handheld transmitters. These transmitters are FCC certified, making product introduction extremely quick. Information on these transmitters can be found on the Linx website at www.linxtechnologies.com.



Figure 18: Linx Remote Control Transmitters

Antenna Considerations

The choice of antennas is a critical and often overlooked design consideration. The range, performance and legality of an RF link are critically dependent upon the antenna. While adequate antenna performance can often be obtained by trial and error methods, antenna design and matching is a complex



Figure 19: Linx Antennas

task. Professionally designed antennas such as those from Linx (Figure 19) help ensure maximum performance and FCC and other regulatory compliance.

Linx transmitter modules typically have an output power that is higher than the legal limits. This allows the designer to use an inefficient antenna such as a loop trace or helical to meet size, cost or cosmetic requirements and still achieve full legal output power for maximum range. If an efficient antenna is used, then some attenuation of the output power will likely be needed. This can easily be accomplished by using the LADJ line.

It is usually best to utilize a basic quarter-wave whip until your prototype product is operating satisfactorily. Other antennas can then be evaluated based on the cost, size and cosmetic requirements of the product. Additional details are in Application Note AN-00500.

Helpful Application Notes from Linx

It is not the intention of this manual to address in depth many of the issues that should be considered to ensure that the modules function correctly and deliver the maximum possible performance. We recommend reading the application notes listed in Figure 20 which address in depth key areas of RF design and application of Linx products. These applications notes are available online at www.linxtechnologies.com or by contacting Linx.

Helpful Application Note Titles	
Note Number	Note Title
AN-00100	RF 101: Information for the RF Challenged
AN-00126	Considerations for Operation Within the 902–928MHz Band
AN-00130	Modulation Techniques for Low-Cost RF Data Links
AN-00140	The FCC Road: Part 15 from Concept to Approval
AN-00150	Use and Design of T-Attenuation Pads
AN-00300	Addressing Linx OEM Products
AN-00500	Antennas: Design, Application, Performance
AN-00501	Understanding Antenna Specifications and Operation

Figure 20: Helpful Application Note Titles

Interference Considerations

The RF spectrum is crowded and the potential for conflict with unwanted sources of RF is very real. While all RF products are at risk from interference, its effects can be minimized by better understanding its characteristics.

Interference may come from internal or external sources. The first step is to eliminate interference from noise sources on the board. This means paying careful attention to layout, grounding, filtering and bypassing in order to eliminate all radiated and conducted interference paths. For many products, this is straightforward; however, products containing components such as switching power supplies, motors, crystals and other potential sources of noise must be approached with care. Comparing your own design with a Linx evaluation board can help to determine if and at what level design-specific interference is present.

External interference can manifest itself in a variety of ways. Low-level interference produces noise and hashing on the output and reduces the link's overall range.

High-level interference is caused by nearby products sharing the same frequency or from near-band high-power devices. It can even come from your own products if more than one transmitter is active in the same area. It is important to remember that only one transmitter at a time can occupy a frequency, regardless of the coding of the transmitted signal. This type of interference is less common than those mentioned previously, but in severe cases it can prevent all useful function of the affected device.

Although technically not interference, multipath is also a factor to be understood. Multipath is a term used to refer to the signal cancellation effects that occur when RF waves arrive at the receiver in different phase relationships. This effect is a particularly significant factor in interior environments where objects provide many different signal reflection paths. Multipath cancellation results in lowered signal levels at the receiver and shorter useful distances for the link.

Pad Layout

The pad layout diagram in Figure 21 is designed to facilitate both hand and automated assembly.

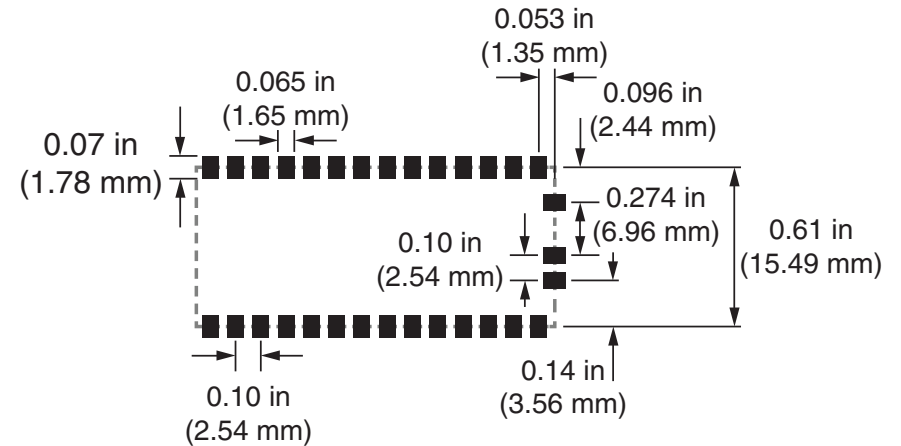

Figure 21: Recommended PCB Layout

Board Layout Guidelines

The module's design makes integration straightforward; however, it is still critical to exercise care in PCB layout. Failure to observe good layout techniques can result in a significant degradation of the module's performance. A primary layout goal is to maintain a characteristic 50-ohm impedance throughout the path from the antenna to the module. Grounding, filtering, decoupling, routing and PCB stack-up are also important considerations for any RF design. The following section provides some basic design guidelines.

During prototyping, the module should be soldered to a properly laid-out circuit board. The use of prototyping or "perf" boards results in poor performance and is strongly discouraged. Likewise, the use of sockets can have a negative impact on the performance of the module and is discouraged.

The module should, as much as reasonably possible, be isolated from other components on your PCB, especially high-frequency circuitry such as crystal oscillators, switching power supplies, and high-speed bus lines.

When possible, separate RF and digital circuits into different PCB regions.

Make sure internal wiring is routed away from the module and antenna and is secured to prevent displacement.

Do not route PCB traces directly under the module. There should not be any copper or traces under the module on the same layer as the module, just bare PCB. The underside of the module has traces and vias that could short or couple to traces on the product's circuit board.

The Pad Layout section shows a typical PCB footprint for the module. A ground plane (as large and uninterrupted as possible) should be placed on a lower layer of your PCB opposite the module. This plane is essential for creating a low impedance return for ground and consistent stripline performance.

Use care in routing the RF trace between the module and the antenna or connector. Keep the trace as short as possible. Do not pass it under the module or any other component. Do not route the antenna trace on multiple PCB layers as vias add inductance. Vias are acceptable for tying together ground layers and component grounds and should be used in multiples.

Each of the module's ground pins should have short traces tying immediately to the ground plane through a via.

Bypass caps should be low ESR ceramic types and located directly adjacent to the pin they are serving.

A 50-ohm coax should be used for connection to an external antenna. A 50-ohm transmission line, such as a microstrip, stripline or coplanar waveguide should be used for routing RF on the PCB. The Microstrip Details section provides additional information.

In some instances, a designer may wish to encapsulate or "pot" the product. There are a wide variety of potting compounds with varying dielectric properties. Since such compounds can considerably impact RF performance and the ability to rework or service the product, it is the responsibility of the designer to evaluate and qualify the impact and suitability of such materials.

Microstrip Details

A transmission line is a medium whereby RF energy is transferred from one place to another with minimal loss. This is a critical factor, especially in high-frequency products like Linx RF modules, because the trace leading to the module's antenna can effectively contribute to the length of the antenna, changing its resonant bandwidth. In order to minimize loss and detuning, some form of transmission line between the antenna and the module should be used unless the antenna can be placed very close (<1/8in) to the module. One common form of transmission line is a coax cable and another is the microstrip. This term refers to a PCB trace running over a ground plane that is designed to serve as a transmission line between the module and the antenna. The width is based on the desired characteristic impedance of the line, the thickness of the PCB and the dielectric constant of the board material. For standard 0.062in thick FR-4 board material, the trace width would be 111 mils. The correct trace width can be calculated for other widths and materials using the information in Figure 22 and examples are provided in Figure 23. Software for calculating microstrip lines is also available on the Linx website.

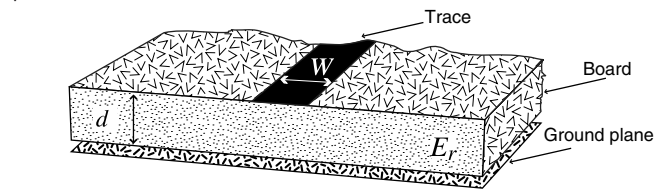

$$E_e = \frac{E_r + 1}{2} + \frac{E_r - 1}{2} \cdot \frac{1}{\sqrt{1 + 12d/W}}$$

$$Z_0 = \begin{cases} \frac{60}{\sqrt{E_e}} \cdot \ln\left(\frac{8d}{W} + \frac{W}{4d}\right) & \text{For } \frac{W}{d} \leq 1 \\ \frac{120\pi}{\sqrt{E_e} \cdot \left(\frac{W}{d} + 1.393 + 0.667 \cdot \ln\left(\frac{W}{d} + 1.444\right)\right)} & \text{For } \frac{W}{d} \geq 1 \end{cases}$$

E_r = Dielectric constant of PCB material

Figure 22: Microstrip Formulas

Example Microstrip Calculations			
Dielectric Constant	Width / Height Ratio (W / d)	Effective Dielectric Constant	Characteristic Impedance (Ω)
4.80	1.8	3.59	50.0
4.00	2.0	3.07	51.0
2.55	3.0	2.12	48.8

Figure 23: Example Microstrip Calculations

Production Guidelines

The module is housed in a hybrid SMD package that supports hand and automated assembly techniques. Since the modules contain discrete components internally, the assembly procedures are critical to ensuring the reliable function of the modules. The following procedures should be reviewed with and practiced by all assembly personnel.

Hand Assembly

Pads located on the bottom of the module are the primary mounting surface (Figure 24). Since these pads are inaccessible during mounting, castellations that run up the side of the module have been provided to facilitate solder wicking to the module's underside. This allows for very

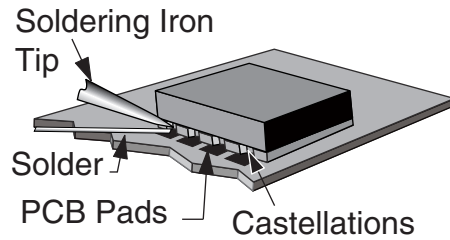

Figure 24: Soldering Technique

quick hand soldering for prototyping and small volume production. If the recommended pad guidelines have been followed, the pads will protrude slightly past the edge of the module. Use a fine soldering tip to heat the board pad and the castellation, then introduce solder to the pad at the module's edge. The solder will wick underneath the module, providing reliable attachment. Tack one module corner first and then work around the device, taking care not to exceed the times in Figure 25.

Warning: Pay attention to the absolute maximum solder times.

Absolute Maximum Solder Times

Hand Solder Temperature: +427°C for 10 seconds for lead-free alloys

Reflow Oven: +255°C max (see Figure 26)

Figure 25: Absolute Maximum Solder Times

Automated Assembly

For high-volume assembly, the modules are generally auto-placed. The modules have been designed to maintain compatibility with reflow processing techniques; however, due to their hybrid nature, certain aspects of the assembly process are far more critical than for other component types. Following are brief discussions of the three primary areas where caution must be observed.

Reflow Temperature Profile

The single most critical stage in the automated assembly process is the reflow stage. The reflow profile in Figure 26 should not be exceeded because excessive temperatures or transport times during reflow will irreparably damage the modules. Assembly personnel need to pay careful attention to the oven's profile to ensure that it meets the requirements necessary to successfully reflow all components while still remaining within the limits mandated by the modules. The figure below shows the recommended reflow oven profile for the modules.

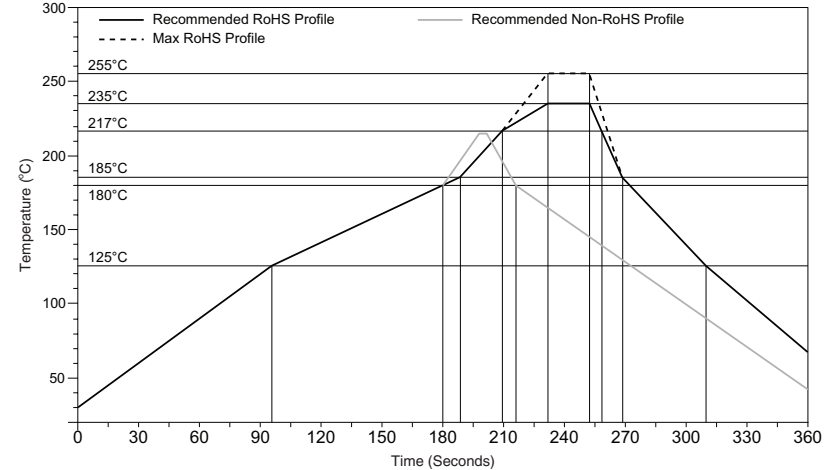

Figure 26: Maximum Reflow Temperature Profile

Shock During Reflow Transport

Since some internal module components may reflow along with the components placed on the board being assembled, it is imperative that the modules not be subjected to shock or vibration during the time solder is liquid. Should a shock be applied, some internal components could be lifted from their pads, causing the module to not function properly.

Washability

The modules are wash-resistant, but are not hermetically sealed. Linx recommends wash-free manufacturing; however, the modules can be subjected to a wash cycle provided that a drying time is allowed prior to applying electrical power to the modules. The drying time should be sufficient to allow any moisture that may have migrated into the module to evaporate, thus eliminating the potential for shorting damage during power-up or testing. If the wash contains contaminants, the performance may be adversely affected, even after drying.

General Antenna Rules

The following general rules should help in maximizing antenna performance.

1. Proximity to objects such as a user's hand, body or metal objects will cause an antenna to detune. For this reason, the antenna shaft and tip should be positioned as far away from such objects as possible.
2. Optimum performance is obtained from a $\frac{1}{4}$ - or $\frac{1}{2}$ -wave straight whip mounted at a right angle to the ground plane (Figure 27). In many cases, this isn't desirable for practical or ergonomic reasons, thus, an alternative antenna style such as a helical, loop or patch may be utilized and the corresponding sacrifice in performance accepted.

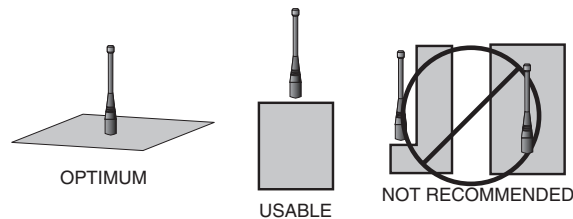

Figure 27: Ground Plane Orientation

3. If an internal antenna is to be used, keep it away from other metal components, particularly large items like transformers, batteries, PCB tracks and ground planes. In many cases, the space around the antenna is as important as the antenna itself. Objects in close proximity to the antenna can cause direct detuning, while those farther away will alter the antenna's symmetry.
4. In many antenna designs, particularly $\frac{1}{4}$ -wave whips, the ground plane acts as a counterpoise, forming, in essence, a $\frac{1}{2}$ -wave dipole (Figure 28). For this reason, adequate ground plane area is essential. The ground plane can be a metal case or ground-fill areas on a circuit board. Ideally, it should have a surface area less than or equal to the overall length of the $\frac{1}{4}$ -wave radiating element. This is often not practical due to size and configuration constraints. In these instances, a designer must make the best use of the area available to create as much ground

VERTICAL $\lambda/4$ GROUNDED ANTENNA (MARCONI)

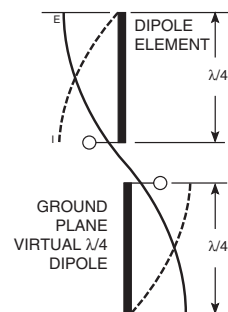

Figure 28: Dipole Antenna

plane as possible in proximity to the base of the antenna. In cases where the antenna is remotely located or the antenna is not in close proximity to a circuit board, ground plane or grounded metal case, a metal plate may be used to maximize the antenna's performance.

5. Remove the antenna as far as possible from potential interference sources. Any frequency of sufficient amplitude to enter the receiver's front end will reduce system range and can even prevent reception entirely. Switching power supplies, oscillators or even relays can also be significant sources of potential interference. The single best weapon against such problems is attention to placement and layout. Filter the module's power supply with a high-frequency bypass capacitor. Place adequate ground plane under potential sources of noise to shunt noise to ground and prevent it from coupling to the RF stage. Shield noisy board areas whenever practical.
6. In some applications, it is advantageous to place the module and antenna away from the main equipment (Figure 29). This can avoid interference problems and allows the antenna to be oriented for optimum performance. Always use 50Ω coax, like RG-174, for the remote feed.

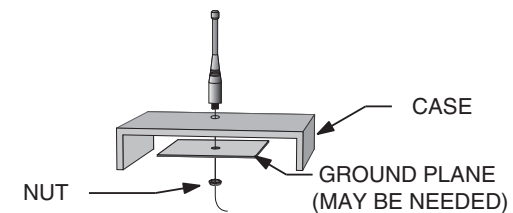

Figure 29: Remote Ground Plane

Common Antenna Styles

There are hundreds of antenna styles and variations that can be employed with Linx RF modules. Following is a brief discussion of the styles most commonly utilized. Additional antenna information can be found in Linx Application Notes AN-00100, AN-00140, AN-00500 and AN-00501. Linx antennas and connectors offer outstanding performance at a low price.

Whip Style

A whip style antenna (Figure 30) provides outstanding overall performance and stability. A low-cost whip can be easily fabricated from a wire or rod, but most designers opt for the consistent performance and cosmetic appeal of a professionally-made model. To meet this need, Linx offers a wide variety of straight and reduced height whip style antennas in permanent and connectorized mounting styles.



Figure 30: Whip Style Antennas

The wavelength of the operational frequency determines an antenna's overall length. Since a full wavelength is often quite long, a partial 1/2- or 1/4-wave antenna is normally employed. Its size and natural radiation resistance make it well matched to Linx modules. The proper length for a straight 1/4-wave can be easily determined using the formula in Figure 31. It is also possible to reduce the overall height of the antenna by using a helical winding. This reduces the antenna's bandwidth but is a great way to minimize the antenna's physical size for compact applications. This also means that the physical appearance is not always an indicator of the antenna's frequency.

$$L = \frac{234}{F_{\text{MHz}}}$$

Figure 31:
L = length in feet of quarter-wave length
F = operating frequency in megahertz

Specialty Styles

Linx offers a wide variety of specialized antenna styles (Figure 32). Many of these styles utilize helical elements to reduce the overall antenna size while maintaining reasonable performance. A helical antenna's bandwidth is often quite narrow and the antenna can detune in proximity to other objects, so care must be exercised in layout and placement.



Figure 32: Specialty Style Antennas

Loop Style

A loop or trace style antenna is normally printed directly on a product's PCB (Figure 33). This makes it the most cost-effective of antenna styles. The element can be made self-resonant or externally resonated with discrete components, but its actual layout is usually product specific. Despite the cost advantages, loop style antennas are generally inefficient and useful only for short range applications. They are also very sensitive to changes in layout and PCB dielectric, which can cause consistency issues during production. In addition, printed styles are difficult to engineer, requiring the use of expensive equipment including a network analyzer. An improperly designed loop will have a high VSWR at the desired frequency which can cause instability in the RF stage.



Figure 33: Loop or Trace Antenna

Linx offers low-cost planar (Figure 34) and chip antennas that mount directly to a product's PCB. These tiny antennas do not require testing and provide excellent performance despite their small size. They offer a preferable alternative to the often problematic "printed" antenna.

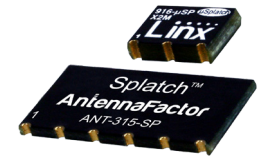

Figure 34: SP Series "Splatch" and uSP "MicroSplatch" Antennas

Regulatory Considerations

Note: Linx RF modules are designed as component devices that require external components to function. The purchaser understands that additional approvals may be required prior to the sale or operation of the device, and agrees to utilize the component in keeping with all laws governing its use in the country of operation.

When working with RF, a clear distinction must be made between what is technically possible and what is legally acceptable in the country where operation is intended. Many manufacturers have avoided incorporating RF into their products as a result of uncertainty and even fear of the approval and certification process. Here at Linx, our desire is not only to expedite the design process, but also to assist you in achieving a clear idea of what is involved in obtaining the necessary approvals to legally market a completed product.

For information about regulatory approval, read AN-00142 on the Linx website or call Linx. Linx designs products with worldwide regulatory approval in mind.

In the United States, the approval process is actually quite straightforward. The regulations governing RF devices and the enforcement of them are the responsibility of the Federal Communications Commission (FCC). The regulations are contained in Title 47 of the United States Code of Federal Regulations (CFR). Title 47 is made up of numerous volumes; however, all regulations applicable to this module are contained in Volume 0-19. It is strongly recommended that a copy be obtained from the FCC's website, the Government Printing Office in Washington or from your local government bookstore. Excerpts of applicable sections are included with Linx evaluation kits or may be obtained from the Linx Technologies website, www.linxtechnologies.com. In brief, these rules require that any device that intentionally radiates RF energy be approved, that is, tested for compliance and issued a unique identification number. This is a relatively painless process. Final compliance testing is performed by one of the many independent testing laboratories across the country. Many labs can also provide other certifications that the product may require at the same time, such as UL, CLASS A / B, etc. Once the completed product has passed, an ID number is issued that is to be clearly placed on each product manufactured.

Questions regarding interpretations of the Part 2 and Part 15 rules or the measurement procedures used to test intentional radiators such as Linx RF modules for compliance with the technical standards of Part 15 should be addressed to:

Federal Communications Commission
Equipment Authorization Division
Customer Service Branch, MS 1300F2
7435 Oakland Mills Road
Columbia, MD, US 21046
Phone: + 1 301 725 585 | Fax: + 1 301 344 2050
Email: labinfo@fcc.gov

ETSI Secretaria
650, Route des Lucioles
06921 Sophia-Antipolis Cedex
FRANCE
Phone: +33 (0)4 92 94 42 00
Fax: +33 (0)4 93 65 47 16

International approvals are slightly more complex, although Linx modules are designed to allow all international standards to be met. If the end product is to be exported to other countries, contact Linx to determine the specific suitability of the module to the application.

All Linx modules are designed with the approval process in mind and thus much of the frustration that is typically experienced with a discrete design is eliminated. Approval is still dependent on many factors, such as the choice of antennas, correct use of the frequency selected and physical packaging. While some extra cost and design effort are required to address these issues, the additional usefulness and profitability added to a product by RF makes the effort more than worthwhile.

Notes



Linx Technologies
159 Ort Lane
Merlin, OR, US 97532

Phone: +1 541 471 6256
Fax: +1 541 471 6251

www.linxtechnologies.com

Disclaimer

Linx Technologies is continually striving to improve the quality and function of its products. For this reason, we reserve the right to make changes to our products without notice. The information contained in this Data Guide is believed to be accurate as of the time of publication. Specifications are based on representative lot samples. Values may vary from lot-to-lot and are not guaranteed. "Typical" parameters can and do vary over lots and application. Linx Technologies makes no guarantee, warranty, or representation regarding the suitability of any product for use in any specific application. It is the customer's responsibility to verify the suitability of the part for the intended application. **NO LINX PRODUCT IS INTENDED FOR USE IN ANY APPLICATION WHERE THE SAFETY OF LIFE OR PROPERTY IS AT RISK.**

Linx Technologies **DISCLAIMS ALL WARRANTIES OF MERCHANTABILITY AND FITNESS FOR A PARTICULAR PURPOSE. IN NO EVENT SHALL LINX TECHNOLOGIES BE LIABLE FOR ANY OF CUSTOMER'S INCIDENTAL OR CONSEQUENTIAL DAMAGES ARISING IN ANY WAY FROM ANY DEFECTIVE OR NON-CONFORMING PRODUCTS OR FOR ANY OTHER BREACH OF CONTRACT BY LINX TECHNOLOGIES.** The limitations on Linx Technologies' liability are applicable to any and all claims or theories of recovery asserted by Customer, including, without limitation, breach of contract, breach of warranty, strict liability, or negligence. Customer assumes all liability (including, without limitation, liability for injury to person or property, economic loss, or business interruption) for all claims, including claims from third parties, arising from the use of the Products. The Customer will indemnify, defend, protect, and hold harmless Linx Technologies and its officers, employees, subsidiaries, affiliates, distributors, and representatives from and against all claims, damages, actions, suits, proceedings, demands, assessments, adjustments, costs, and expenses incurred by Linx Technologies as a result of or arising from any Products sold by Linx Technologies to Customer. Under no conditions will Linx Technologies be responsible for losses arising from the use or failure of the device in any application, other than the repair, replacement, or refund limited to the original product purchase price. Devices described in this publication may contain proprietary, patented, or copyrighted techniques, components, or materials. Under no circumstances shall any user be conveyed any license or right to the use or ownership of such items.

©2014 Linx Technologies. All rights reserved.

The stylized Linx logo, Wireless Made Simple, WISE, CipherLinx and the stylized CL logo are trademarks of Linx Technologies.



Компания «ЭлектроПласт» предлагает заключение долгосрочных отношений при поставках импортных электронных компонентов на взаимовыгодных условиях!

Наши преимущества:

- Оперативные поставки широкого спектра электронных компонентов отечественного и импортного производства напрямую от производителей и с крупнейших мировых складов;
- Поставка более 17-ти миллионов наименований электронных компонентов;
- Поставка сложных, дефицитных, либо снятых с производства позиций;
- Оперативные сроки поставки под заказ (от 5 рабочих дней);
- Экспресс доставка в любую точку России;
- Техническая поддержка проекта, помощь в подборе аналогов, поставка прототипов;
- Система менеджмента качества сертифицирована по Международному стандарту ISO 9001;
- Лицензия ФСБ на осуществление работ с использованием сведений, составляющих государственную тайну;
- Поставка специализированных компонентов (Xilinx, Altera, Analog Devices, Intersil, Interpoint, Microsemi, Aeroflex, Peregrine, Syfer, Eurofarad, Texas Instrument, Miteq, Cobham, E2V, MA-COM, Hittite, Mini-Circuits, General Dynamics и др.);

Помимо этого, одним из направлений компании «ЭлектроПласт» является направление «Источники питания». Мы предлагаем Вам помощь Конструкторского отдела:

- Подбор оптимального решения, техническое обоснование при выборе компонента;
- Подбор аналогов;
- Консультации по применению компонента;
- Поставка образцов и прототипов;
- Техническая поддержка проекта;
- Защита от снятия компонента с производства.



Как с нами связаться

Телефон: 8 (812) 309 58 32 (многоканальный)

Факс: 8 (812) 320-02-42

Электронная почта: org@eplast1.ru

Адрес: 198099, г. Санкт-Петербург, ул. Калинина, дом 2, корпус 4, литера А.