

MAX77324 Evaluation Kit

Evaluates: MAX77324

General Description

The MAX77324 evaluation kit (EV kit) provides a proven design to evaluate a high-efficiency synchronous step-down DC-DC converter with integrated MOSFETs that operate over a 2.5V to 4.8V input voltage range, 0.6V to 2V output voltage range, and supports up to 1.5A of load current. The device automatically transitions between PWM and SKIP modes of operation when the load condition changes.

Benefits and Features

- Proven PCB Reference Design and Layout
- Fully Assembled and Tested
- Sense Points for High-Accuracy Measurements
- Test Point and Jumper for Enable

[Ordering Information](#) appears at end of data sheet.

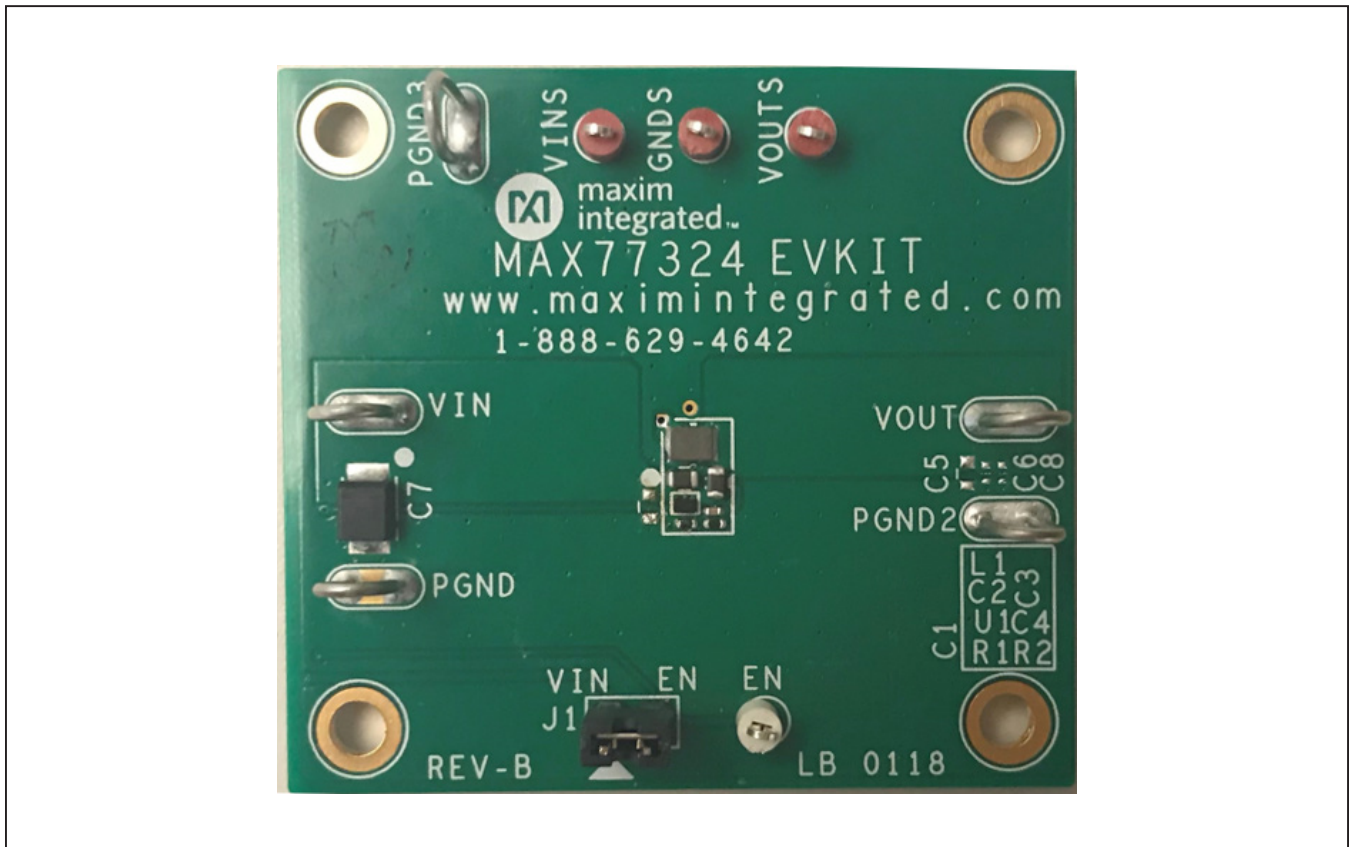

Figure 1. MAX77324 EV Kit Photo

Quick Start

Required Equipment

- MAX77324 EV kit
- Power supply with 6V and 1A capability
- Two digital voltmeter (DVM)
- Ammeter

Procedure

The EV kit is fully assembled and tested. Follow these steps to verify board operation:

- 1) Install J1 as recommended in [Table 1](#).
- 2) Connect a disabled 3.8V bench power supply through an ammeter to the V_{IN} and PGND inputs. Set the input current limit of the bench power supply to 100mA. Set the ammeter range to its 10mA setting. **Do not** enable the output of the bench supply until prompted.
- 3) Connect a voltmeter to the VINS and GNDS terminals to measure input voltage.
- 4) Connect a voltmeter to the VOULTS and GNDS terminals to measure output voltage.
- 5) Enable the output of the bench power supply.
- 6) At this point, your setup is complete and the device under test (DUT) is Enabled. Confirm that your input current ammeter has $\sim 45\mu A$.
- 7) If the input current in the above step is correct, increase the input current limit of the bench supply to 1A. Also, increase the input ammeter range to 3A.
- 8) Observe the output voltage on the voltmeter between VOULTS and GNDS. Confirm that the output voltage matches the expected output voltage (refer to the *Setting the Output Voltage* section of the data sheet).
 - At higher load/input currents, the input current ammeter must either be set to a higher range or bypassed, so as not to drop the input voltage (measured at VINS) below operating voltages.

Detailed Description

Enabling and Disabling the Regulator

Turn on the device by installing a jumper between positions 1-2 on J1. The jumper connects the EN pin to V_{IN} , enabling the regulator with soft-start. Remove jumper J1 to disable the regulator. EN has an internal pulldown resistor to ground.

Table 1. Default Shunt Positions and Jumper Descriptions

REFERENCE DESIGNATOR	DEFAULT POSITION	FUNCTION
J1	1-2	1-2: Connects EN to V_{IN} to enable the regulator. Open: Disconnect EN from V_{IN} to disable the regulator. EN has an internal pulldown resistor to ground.

Table 2. Setting the Output Voltage

V_{OUT} (V)	R_{TOP} (k Ω)	R_{BOT} (k Ω)	C_{TOP} (pF)
0.6	Short	Open	Open
0.85	12.4	30.1	220
0.9	15	30.1	220
0.95	17.8	30.1	220
1.0	20	30.1	220
1.1	24.8	30.1	220
1.2	30.1	30.1	220
1.35	37.4	30.1	220
1.5	45.3	30.1	220
1.8	60.4	30.1	220
2.0	69.8	30.1	220

Setting the Output Voltage

The device uses resistors to set the output voltage between 0.6V and 2V. Connect a resistor divider between V_{OUT} , FB, and AGND as shown in [Figure 2](#). Choose R_{BOT} (FB to AGND) to be less than or equal to 30.1kΩ. One percent accuracy resistors are highly recommended to keep the accuracy of V_{OUT} . Calculate the value of R_{TOP} (V_{OUT} to FB) for a desired output voltage with Equation 1.

Equation 1:

$$R_{TOP} = R_{BOT} \times \left[\frac{V_{OUT}}{V_{FB}} - 1 \right]$$

Where V_{FB} is 0.6V and V_{OUT} is the desired output voltage.

C_{TOP} is to maintain the stability of the device. Suggest C_{TOP} to be 220pF for the full operation range of the device.

Ordering Information

PART	TYPE
MAX77324EVKIT#	EV Kit

#Denotes RoHS compliant.

On the MAX77324 evaluation board, default V_{OUT} is set to 1.2V by choosing the value of both R_{BOT} and R_{TOP} to be equal (30.1kΩ).

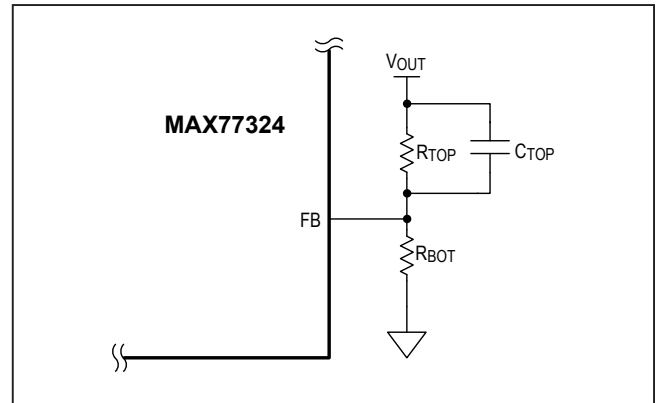
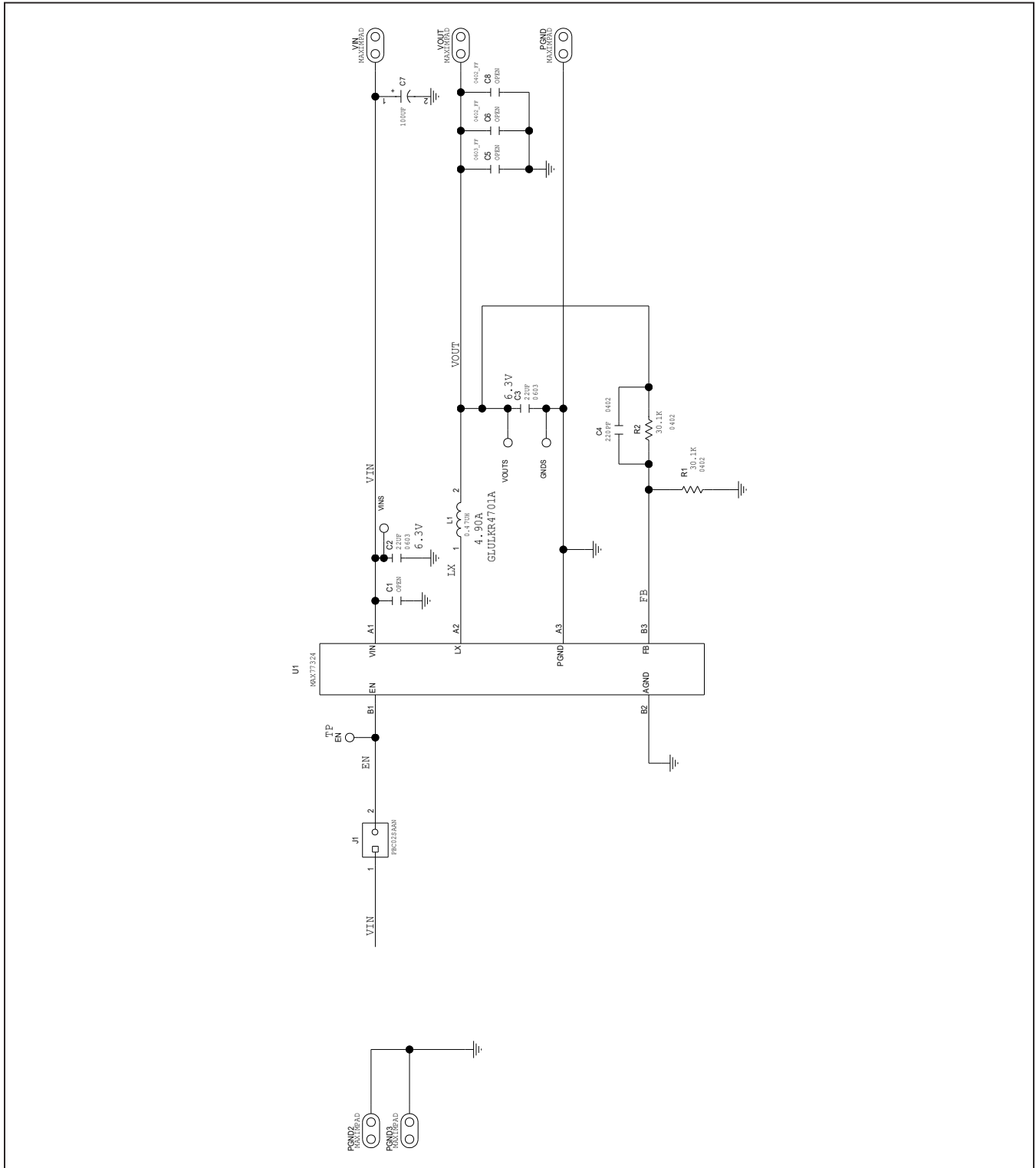

Figure 2. Setting the Output Voltage for MAX77324

MAX77324 EV Kit Bill of Materials

PART	QTY	DESCRIPTION
C2, C3	2	22 μ F \pm 20%, 6.3V, X5R ceramic capacitor (0603) C1608X5R0J226M080AC
C4	1	220pF \pm 10%, 50V, X7R ceramic capacitor (0402) GRM155R71H221KA01
C7	1	100 μ F \pm 20%, 6.3V, tantalum capacitor (3528) TCJB107M006R0070
J1	1	2-Pin header
L1	1	0.47 μ H \pm 20%, 4.90A inductor (2520) GLULKR4701A
R1, R2	2	30.1k Ω \pm 1% resistor (0402)
U1	1	MAX77324EWTAD+ (6 WLP)
C1, C5	0	Not installed, capacitor (0603)
C6, C8	0	Not installed, capacitor (0402)
—	1	Shunt
—	1	PCB: MAX77324 EV Kit

MAX77324 EV Schematic



MAX77324 EV PCB Layout

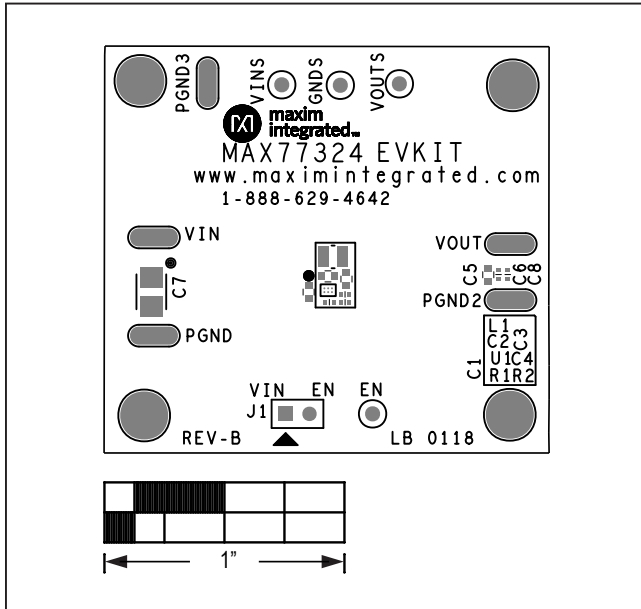

MAX77324 EV Kit Component Placement Guide—Top Silkscreen

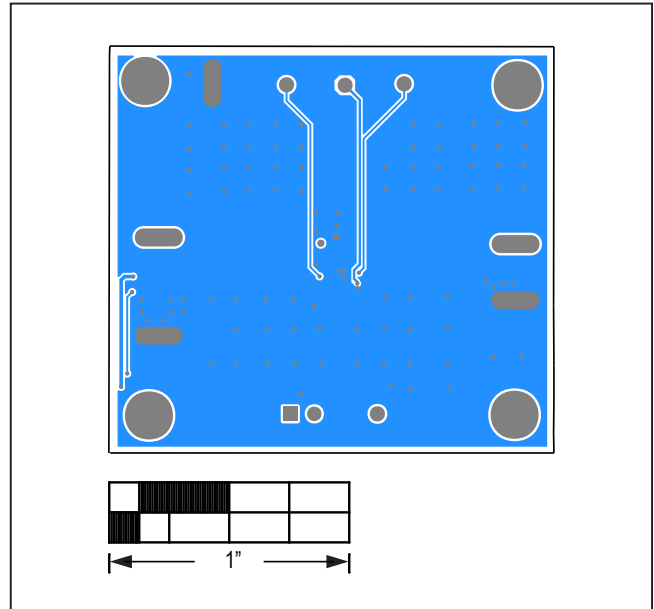

MAX77324 EV Kit PCB Layout—Bottom

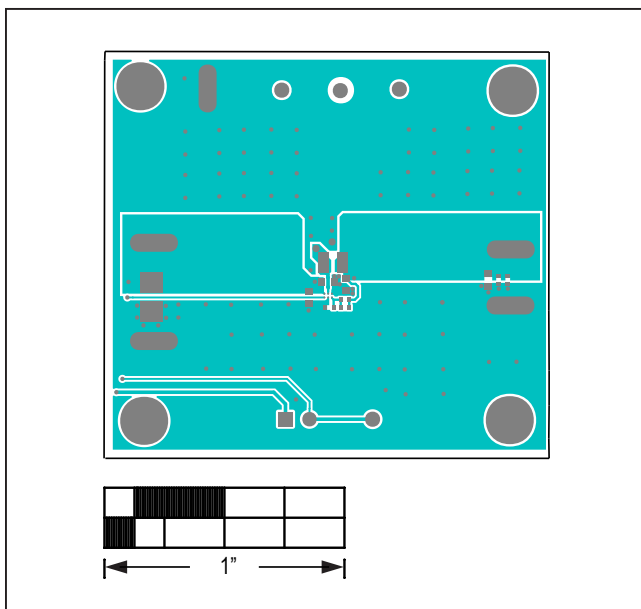

MAX77324 EV Kit PCB Layout—Top

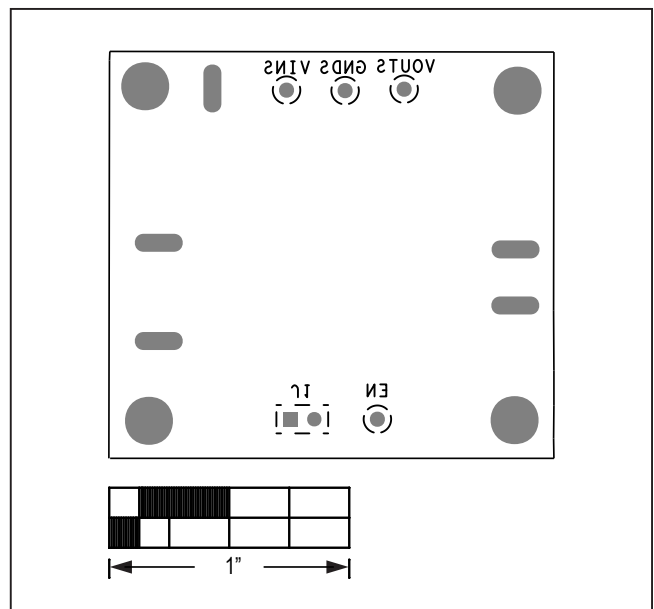

MAX77324 EV Kit Component Placement Guide—Bottom Silkscreen

Revision History

REVISION NUMBER	REVISION DATE	DESCRIPTION	PAGES CHANGED
0	5/18	Initial release	—

For pricing, delivery, and ordering information, please contact Maxim Direct at 1-888-629-4642, or visit Maxim Integrated's website at www.maximintegrated.com.

Maxim Integrated cannot assume responsibility for use of any circuitry other than circuitry entirely embodied in a Maxim Integrated product. No circuit patent licenses are implied. Maxim Integrated reserves the right to change the circuitry and specifications without notice at any time.



Компания «ЭлектроПласт» предлагает заключение долгосрочных отношений при поставках импортных электронных компонентов на взаимовыгодных условиях!

Наши преимущества:

- Оперативные поставки широкого спектра электронных компонентов отечественного и импортного производства напрямую от производителей и с крупнейших мировых складов;
- Поставка более 17-ти миллионов наименований электронных компонентов;
- Поставка сложных, дефицитных, либо снятых с производства позиций;
- Оперативные сроки поставки под заказ (от 5 рабочих дней);
- Экспресс доставка в любую точку России;
- Техническая поддержка проекта, помощь в подборе аналогов, поставка прототипов;
- Система менеджмента качества сертифицирована по Международному стандарту ISO 9001;
- Лицензия ФСБ на осуществление работ с использованием сведений, составляющих государственную тайну;
- Поставка специализированных компонентов (Xilinx, Altera, Analog Devices, Intersil, Interpoint, Microsemi, Aeroflex, Peregrine, Syfer, Eurofarad, Texas Instrument, Miteq, Cobham, E2V, MA-COM, Hittite, Mini-Circuits, General Dynamics и др.);

Помимо этого, одним из направлений компании «ЭлектроПласт» является направление «Источники питания». Мы предлагаем Вам помощь Конструкторского отдела:

- Подбор оптимального решения, техническое обоснование при выборе компонента;
- Подбор аналогов;
- Консультации по применению компонента;
- Поставка образцов и прототипов;
- Техническая поддержка проекта;
- Защита от снятия компонента с производства.



Как с нами связаться

Телефон: 8 (812) 309 58 32 (многоканальный)

Факс: 8 (812) 320-02-42

Электронная почта: org@eplast1.ru

Адрес: 198099, г. Санкт-Петербург, ул. Калинина, дом 2, корпус 4, литера А.