



FCIconnect.com

Copyright FCI

1

2

List of "SFV__R-1/2STAE1LF" customer document

DOCUMENT NO.	LIST
SC-SFV06	SPEC.
JSA96245	CAT.NO.TABLE FOR 0.5mm CONTACT SPACING CONNECTOR (SFV__R-1/2STA_LF)
JSA96246	CONNECTOR USED FOR FPC/FFC WITH 0.5mm CONTACT SPACING (SFV__R-1STA_LF)
JSA96247	CONNECTOR USED FOR FPC/FFC WITH 0.5mm CONTACT SPACING (SFV__R-2STA_LF)
JSA96248	CAT.NO.TABLE FOR PLASTIC TAPE PACKAGED 0.5mm CONTACT SPACING CONNECTOR (SFV__R-1/2STAE1LF)
JSA96249	PLASTIC TAPE PACKAGED 0.5mm CONTACT SPACING CONNECTOR (SFV__R-1STAE1LF)
JSA96250	PLASTIC TAPE PACKAGED 0.5mm CONTACT SPACING CONNECTOR (SFV__R-2STAE1LF)
JSA96004	RECOMMENDED CABLE (FPC) (SFV__R-1/2STA_...)
JSA97202	RECOMMENDED CABLE (FFC) (SFV__R-1/2ST_...)
BJM-SFV101	HANDLING PROCEDURES

mat'l. code				surface ISO 1302 <input checked="" type="checkbox"/> ISO 406 ISO 1101		tolerance ISO 406 ISO 1101		projection 		product family 58EF		
ltr	ecn no	dr	date	tolerances unless otherwise specified				 scale X		title 0.5mm SPACING FPC CONNECTOR DOCUMENT LIST (Cat. No. : SFV__R-1/2STAE1LF)		
A	J04-0454	H.T	'05/2/7	angles	linear							
B	J06-0372	H.T	'06/9/7									
C	J06-0499	H.T	'06/11/27					scale X		dwg no JSA 96244		
				dr	<i>K. Shauk</i> 11/27/06					sheet 1of 1		size
				enrg	<i>K. Shauk</i> 11/27/06					A4		
				chr	<i>R. Shauk</i> 11/27/06							
				appd	<i>S. Madam</i> 11/28/06			type Product Customer Drawing		Rev.		
sheet index	revision sheet	C	1									C

form: A4

1

2

CAT. NO. & DIMENSIONS

NO. OF CONTACTS (n)	CAT. NO.	DIMENSIONS (NOTE2)			
		A ± 0.2	B ± 0.2	C ± 0.1	D ± 0.1
4	SFV4R-1/2STA__LF	7.5	5.9	15	2.7
5	SFV5R-1/2STA__LF	8.0	6.4	2.0	3.2
6	SFV6R-1/2STA__LF	8.5	6.9	2.5	3.7
7	SFV7R-1/2STA__LF	9.0	7.4	3.0	4.2
8	SFV8R-1/2STA__LF	9.5	7.9	3.5	4.7
9	SFV9R-1/2STA__LF	10.0	8.4	4.0	5.2
10	SFV10R-1/2STA__LF	10.5	8.9	4.5	5.7
11	SFV11R-1/2STA__LF	11.0	9.4	5.0	6.2
12	SFV12R-1/2STA__LF	11.5	9.9	5.5	6.7
13	SFV13R-1/2STA__LF	12.0	10.4	6.0	7.2
14	SFV14R-1/2STA__LF	12.5	10.9	6.5	7.7
15	SFV15R-1/2STA__LF	13.0	11.4	7.0	8.2
16	SFV16R-1/2STA__LF	13.5	11.9	7.5	8.7
17	SFV17R-1/2STA__LF	14.0	12.4	8.0	9.2
18	SFV18R-1/2STA__LF	14.5	12.9	8.5	9.7
19	SFV19R-1/2STA__LF	15.0	13.4	9.0	10.2
20	SFV20R-1/2STA__LF	15.5	13.9	9.5	10.7
21	SFV21R-1/2STA__LF	16.0	14.4	10.0	11.2
22	SFV22R-1/2STA__LF	16.5	14.9	10.5	11.7
23	SFV23R-1/2STA__LF	17.0	15.4	11.0	12.2
24	SFV24R-1/2STA__LF	17.5	15.9	11.5	12.7
25	SFV25R-1/2STA__LF	18.0	16.4	12.0	13.2
26	SFV26R-1/2STA__LF	18.5	16.9	12.5	13.7
27	SFV27R-1/2STA__LF	19.0	17.4	13.0	14.2
28	SFV28R-1/2STA__LF	19.5	17.9	13.5	14.7
29	SFV29R-1/2STA__LF	20.0	18.4	14.0	15.2
30	SFV30R-1/2STA__LF	20.5	18.9	14.5	15.7
31	SFV31R-1/2STA__LF	21.0	19.4	15.0	16.2
32	SFV32R-1/2STA__LF	21.5	19.9	15.5	16.7
33	SFV33R-1/2STA__LF	22.0	20.4	16.0	17.2
34	SFV34R-1/2STA__LF	22.5	20.9	16.5	17.7
35	SFV35R-1/2STA__LF	23.0	21.4	17.0	18.2

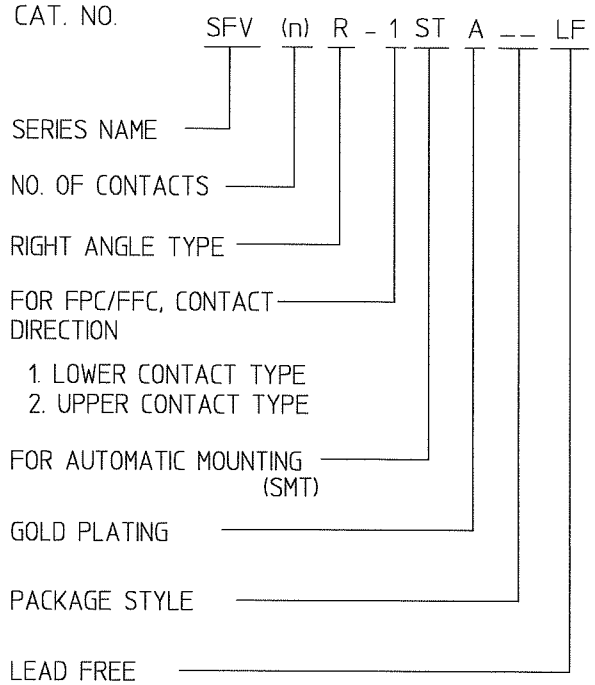

NOTES

- THIS PRODUCT IS THE CONNECTOR USED FOR FPC AND COPEs WITH AUTOMATIC MOUNTING (SMT).
- SEE PART DRAWINGS FOR DIMENSIONS A-D.

mat'l. code				surface ISO 1302 ✓		tolerance ISO 406 ISO 1101		projection		product family 58EF			
ltr		ecn no		dr		date		tolerances unless otherwise specified		title		sheet 1 of 1	
A		J04-0454		H.T		'05/2/7		angles		CAT. NO. TABLE FOR 0.5 mm CONTACT SPACING CONNECTOR (Cat. No. : SFV__R-1/2STA__LF)		size A4	
B		J06-0372		H.T		'06/9/7		linear		scale X		type Product Customer Drawing	
				dr		9/7/06				FCI		sheet 1 of 1	
				enrg		9/7/06						JSA 96245	
				chr		9/8/06						A4	
				appd		9/10/06						Rev. B	
sheet index		revision sheet		B		1						Rev. B	

SC-SFV06 JSA96246, 96247, 96248, 96004 form: A4

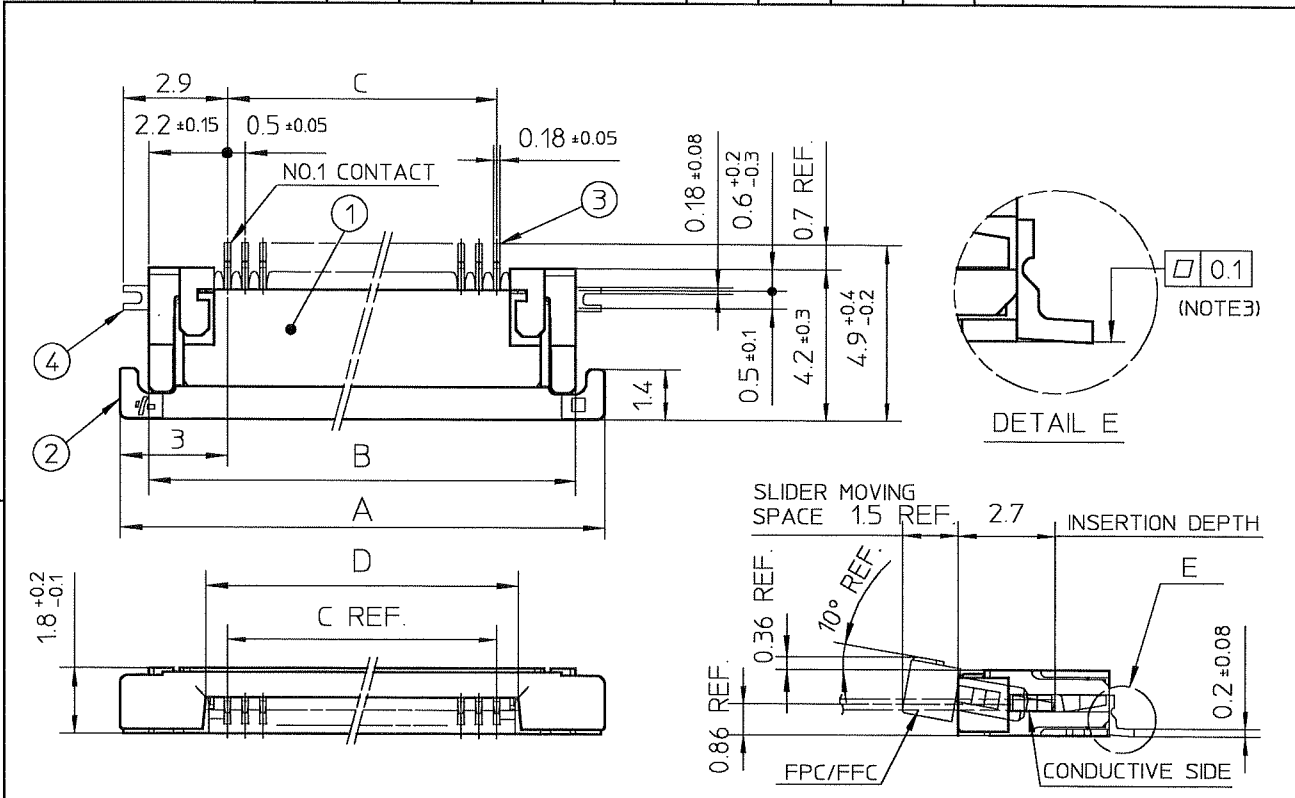

PT. NO.	PARTS NAME	MATERIAL	Q'TY	NOTE
1	HOUSING	POLYAMIDE RESIN GLASS REINFORCED (UL94V-0)	1	COLOR : BLACK
2	SLIDER	PPS RESIN GLASS REINFORCED (UL94V-0)	1	COLOR : BROWN
3	CONTACT	PHOSPHOR BRONZE	n	PLATING : CONTACT AREA GOLD TERMINAL AREA TIN
4	MOUNTING PLATE		2	PLATING : LEAD FREE

RECOMMENDED PC BOARD LAYOUT (COMPONENT SIDE)

PATTERN FOR MOUNTING PLATE FIXING

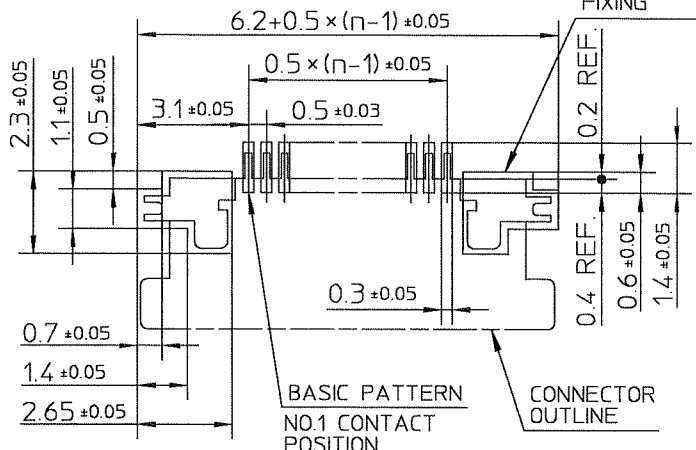

n : NO. OF CONTACTS

NOTES

1. THIS PRODUCT IS THE CONNECTOR USED FOR FPC AND COPES WITH AUTOMATIC MOUNTING (SMT).
2. THIS PRODUCT IS LOWER CONTACT TYPE CONNECTOR.
3. FLATNESS OF CONTACT TERMINAL AND MOUNTING PLATE MUST BE WITHIN TOLERANCE IN E PORTION DETAILED DRAWING.
4. THIS PRODUCT MEETS EUROPEAN UNION DIRECTIVES AND OTHER COUNTRY REGULATIONS AS DESCRIBED IN GS-22-008.
5. THE HOUSING WILL WITHSTAND EXPOSURE TO 260°C PEAK TEMPERATURE FOR 10 SECONDS IN A REFLOW SOLDERING OVEN.

mat'l. code				surface ISO 1302 ✓	tolerance ISO 406 ISO 1101	projection	product family 58EF
ltr	ecn no	dr	date	tolerances unless otherwise specified			title CONNECTOR USED FOR FPC WITH 0.5 mm CONTACT SPACING (Cat No. : SFV__R-1STA__LF)
A	J04-0454	H.T	'05/2/17	angles	linear ±0.2		
B	J05-0710	H.T	'05/10/21				dwg no JSA 96246 sheet 1 of 1 size A4
C	J06-0064	H.T	'06/2/23				
D	J06-0372	H.T	'06/9/17	dr	<i>H. Saito</i> 9/7/06		type Product Customer Drawing
				enr	<i>H. Saito</i> 9/7/06		
				chr	<i>X. Shoji</i> 9/8/06		
				appd	<i>S. Ito</i> 9/1/06		
sheet index	revision sheet	D	1				Rev. D



FCJconnect.com

Copyright FCJ

CAT. NO. & DIMENSIONS

NO. OF CONTACTS (n)	CAT. NO.	DIMENSIONS (NOTE3)		
		F ± 5	G ± 0.3	H ± 0.1
4	SFV4R-1/2STAE1LF	20.4	16	—
5	SFV5R-1/2STAE1LF	20.4	16	—
6	SFV6R-1/2STAE1LF	20.4	16	—
7	SFV7R-1/2STAE1LF	28.4	24	—
8	SFV8R-1/2STAE1LF	28.4	24	—
9	SFV9R-1/2STAE1LF	28.4	24	—
10	SFV10R-1/2STAE1LF	28.4	24	—
11	SFV11R-1/2STAE1LF	28.4	24	—
12	SFV12R-1/2STAE1LF	28.4	24	—
13	SFV13R-1/2STAE1LF	28.4	24	—
14	SFV14R-1/2STAE1LF	28.4	24	—
15	SFV15R-1/2STAE1LF	28.4	24	—
16	SFV16R-1/2STAE1LF	28.4	24	—
17	SFV17R-1/2STAE1LF	28.4	24	—
18	SFV18R-1/2STAE1LF	28.4	24	—
19	SFV19R-1/2STAE1LF	28.4	24	—
20	SFV20R-1/2STAE1LF	28.4	24	—
21	SFV21R-1/2STAE1LF	28.4	24	—
22	SFV22R-1/2STAE1LF	28.4	24	—
23	SFV23R-1/2STAE1LF	36.4	32	28.4
24	SFV24R-1/2STAE1LF	36.4	32	28.4
25	SFV25R-1/2STAE1LF	36.4	32	28.4
26	SFV26R-1/2STAE1LF	36.4	32	28.4
27	SFV27R-1/2STAE1LF	36.4	32	28.4
28	SFV28R-1/2STAE1LF	36.4	32	28.4
29	SFV29R-1/2STAE1LF	36.4	32	28.4
30	SFV30R-1/2STAE1LF	36.4	32	28.4
31	SFV31R-1/2STAE1LF	48.4	44	40.4
32	SFV32R-1/2STAE1LF	48.4	44	40.4
33	SFV33R-1/2STAE1LF	48.4	44	40.4
34	SFV34R-1/2STAE1LF	48.4	44	40.4
35	SFV35R-1/2STAE1LF	48.4	44	40.4

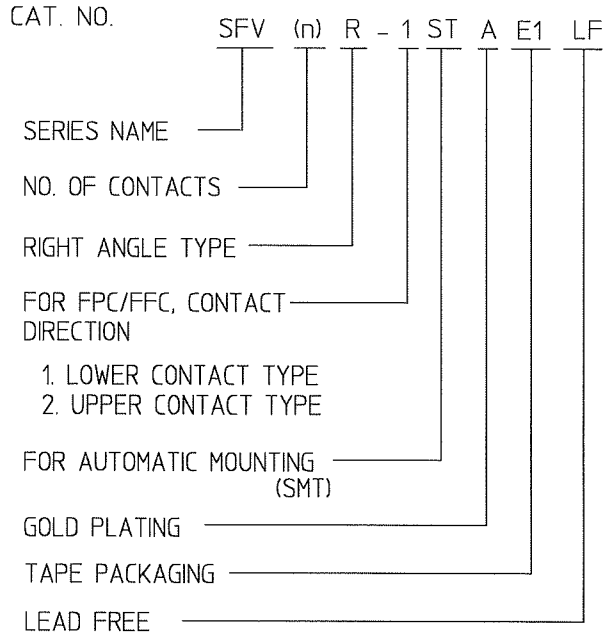

NOTES

1. THIS PRODUCT IS THE CONNECTOR USED FOR FPC AND COPEs WITH AUTOMATIC MOUNTING (SMT).
2. THIS CATALOG NO. INDICATES PLASTIC TAPE PACKAGED CONNECTOR.
3. SEE PART DRAWINGS FOR DIMENSIONS F-H.

mat'l. code				surface ISO 1302 <input checked="" type="checkbox"/>		tolerance ISO 406 ISO 1101		projection		product family 58EF			
ltr		ecn no		dr		date		tolerances unless otherwise specified		title			
A		J04-0454		H.T		'05/2/17		angles		CAT. NO. TABLE FOR PLASTIC TAPE PACKAGED 0.5 mm CONTACT SPACING CONNECTOR (Cat. No. : SFV__R-1/2STAE1LF)			
B		J06-0372		H.T		'06/19/17		linear		scale X			
								dr		sheet 1 of 1		size	
								engr		JSA 96248		A4	
								chr		type Product Customer Drawing			
								appd					
sheet index		revision sheet		B		1						Rev. B	

SC-SFV06 JSA96245 96249 96250 form: A4



PT. NO.	PARTS NAME	CAT. NO.	MATERIAL	Q'TY	NOTE
1	REEL	---	CARDBOARD	1	COLOR : WHITE
2	PLASTIC (EMBOSS) TAPE	---	A-PET	---	COLOR : TRANSPARENCY
3	COVER	---	POLYESTER	---	COLOR : TRANSPARENCY
4	CONNECTOR	SFV_R-1STA_LF	SEE ATTACHED DWG.	3000	LOWER CONTACT TYPE

NOTES

1. THIS IS PLASTIC TAPE PACKAGED CONNECTOR USED FOR FPC AND COPES WITH AUTOMATIC MOUNTING (SMT).
2. SEE JIS C 0806 (PACKING OF ELECTRONIC COMPONENTS ON CONTINUOUS TAPES (SURFACE MOUNTING DEVICES)) FOR SHAPE AND DIMENSIONS OF PLASTIC (EMBOSS) TAPE AND REEL.
3. F DIMENSION IS PORTION OF THE CORE.

mat'l. code				surface ISO 1302 ✓		tolerance ISO 406 ISO 1101		projection		product family 58EF		
ltr	ecn no	dr	date	tolerances unless otherwise specified						title		
A	J04-0454	H.T	'05/2/17	angles	linear	±5				PLASTIC TAPE PACKAGED 0.5 mm CONTACT SPACING CONNECTOR (Cat. No. : SFV__R-1STAE1LF)		
B	J06-0372	H.T	'06/9/17			±5°		scale X		dwg no		sheet 1 of 1
				dr						JSA 96249		A4
				enr						type Product Customer Drawing		
				chr						Rev. B		
				appd								
sheet index	revision sheet	B	1									Rev. B

SC-SFV06 JSA96248 form: A4



PT. NO.	PARTS NAME	CAT. NO.	MATERIAL	Q'TY	NOTE
1	REEL	_____	CARDBOARD	1	COLOR : WHITE
2	PLASTIC (EMBOSS) TAPE	_____	A-PET	---	COLOR : TRANSPARENCY
3	COVER	_____	POLYESTER	---	COLOR : TRANSPARENCY
4	CONNECTOR	SFV_R-2STA_LF	SEE ATTACHED DWG.	3000	UPPER CONTACT TYPE

NOTES

1. THIS IS PLASTIC TAPE PACKAGED CONNECTOR USED FOR FPC AND COPES WITH AUTOMATIC MOUNTING (SMT).
2. SEE JIS C 0806 (PACKING OF ELECTRONIC COMPONENTS ON CONTINUOUS TAPES (SURFACE MOUNTING DEVICES)) FOR SHAPE AND DIMENSIONS OF PLASTIC (EMBOSS) TAPE AND REEL.
3. F DIMENSION IS PORTION OF THE CORE.

mat'l. code		surface ISO 1302 ✓		tolerance ISO 406 ISO 1101		projection		product family 58EF		
ltr	ecn no	dr	date	tolerances unless otherwise specified				title		
A	J04-0454	H.T	'05/2/7	angles ±5°	linear	ISO 406		PLASTIC TAPE PACKAGED		
B	J06-0372	H.T	'06/9/7			ISO 1101		0.5 mm CONTACT SPACING CONNECTOR		
				±5°		scale X		title (Cat. No. : SFV_R-2STAE1LF)		
				dr		engr		dwg no		
				chr		appd		sheet 1 of 1		
				9/7/06		9/7/06		size A4		
				9/8/06		9/8/06		JSA 96250		
				9/11/06		9/11/06		type Product Customer Drawing		
sheet index	revision sheet	B	1							Rev. B



FCIconnect.com

Copyright FCI

RECOMMENDED CABLE (FPC)



PT. NO.	PARTS NAME	MATERIAL	THICKNESS(μm)
1	BASE FILM	POLYIMIDE OR POLYESTER OR EQUAL	25
2	CONDUCTOR	COPPER FOIL(PLATING : GOLD)	35
3	OVERLAY	POLYIMIDE OR POLYESTER OR EQUAL	—
4	SUPPORTING TAPE	POLYESTER OR POLYIMIDE OR EQUAL	188

NOTES

1. NO BURR AT EACH PORTION.
2. NO PEELING IN COMMON USE.
3. TOTAL THICKNESS LIMIT OF EACH MATERIAL (INCLUDING ADHESIVE AGENT) IS SPECIFIED.

mat'l. code				surface ISO 1302 ✓		tolerance ISO 406 ISO 1101		projection ⊕		product family 58EF		
ltr	ecn no	dr	date	tolerances unless otherwise specified				title RECOMMENDED CABLE (Cat. No. : SFV__R-1/2STA__)				
A	J04-0182	H.T	'04/7/15	angles		linear		scale X				
B	J06-0372	H.T	'06/9/7					FCI		dwg no JSA 96004		
				dr K. Suda 9/7/06		engr H. Suda 9/9/06		chr R. Suda 9/8/06		sheet 1 of 1 size A4		
				appd S. Suda 9/11/06						type Product Customer Drawing		
sheet index	revision sheet	B	1									Rev. B

SC-SFV05 JSA95998
form: A4

RECOMMENDED CABLE (FFC)

n : NO. OF CONTACTS



KIND OF FFC (NOTE3)	DIMENSIONAL TOLERANCE			
	a	b	c	d
1	±0.07	±0.04	±0.05	±0.02
2	±0.1	±0.03	±0.03	±0.025

PT. NO.	PARTS NAME	MATERIAL
1	INSULATOR	FLAME RESISTING POLYESTER OR EQUAL
2	CONDUCTOR	COPPER FOIL (PLATING : GOLD)
3	SUPPORTING TAPE	FLAME RESISTING POLYESTER OR EQUAL

NOTES

1. NO BURR AT EACH PORTION.
2. NO PEELING IN COMMON USE.
3. EITHER KIND1 OR KIND2 OF FFC CAN ACCEPT DIMENSIONAL TOLERANCE a,b,c AND d.

mat'l. code				surface ISO 1302 ✓	tolerance ISO 406 ISO 1101	projection	product family 58EF			
ltr	ecn no	dr	date	tolerances unless otherwise specified		scale \times	title			
A	J06-0499	H.T	11/27/06	angles	linear		RECOMMENDED CABLE (Cat. No. : SFV__R-1/2ST__)			
				dr	<i>[Signature]</i> 11/27/06		dwg no		sheet 1 of 1	size
				enr	<i>[Signature]</i> 11/27/06		JSA 97202			A4
				chr	<i>[Signature]</i> 11/27/06		type Product Customer Drawing			
				appd	<i>[Signature]</i> 11/28/06					
sheet index	revision sheet	A	1				Rev. A			



FCJconnect.com

Copyright FCJ



Компания «ЭлектроПласт» предлагает заключение долгосрочных отношений при поставках импортных электронных компонентов на взаимовыгодных условиях!

Наши преимущества:

- Оперативные поставки широкого спектра электронных компонентов отечественного и импортного производства напрямую от производителей и с крупнейших мировых складов;
- Поставка более 17-ти миллионов наименований электронных компонентов;
- Поставка сложных, дефицитных, либо снятых с производства позиций;
- Оперативные сроки поставки под заказ (от 5 рабочих дней);
- Экспресс доставка в любую точку России;
- Техническая поддержка проекта, помощь в подборе аналогов, поставка прототипов;
- Система менеджмента качества сертифицирована по Международному стандарту ISO 9001;
- Лицензия ФСБ на осуществление работ с использованием сведений, составляющих государственную тайну;
- Поставка специализированных компонентов (Xilinx, Altera, Analog Devices, Intersil, Interpoint, Microsemi, Aeroflex, Peregrine, Syfer, Eurofarad, Texas Instrument, Miteq, Cobham, E2V, MA-COM, Hittite, Mini-Circuits, General Dynamics и др.);

Помимо этого, одним из направлений компании «ЭлектроПласт» является направление «Источники питания». Мы предлагаем Вам помощь Конструкторского отдела:

- Подбор оптимального решения, техническое обоснование при выборе компонента;
- Подбор аналогов;
- Консультации по применению компонента;
- Поставка образцов и прототипов;
- Техническая поддержка проекта;
- Защита от снятия компонента с производства.



Как с нами связаться

Телефон: 8 (812) 309 58 32 (многоканальный)

Факс: 8 (812) 320-02-42

Электронная почта: org@eplast1.ru

Адрес: 198099, г. Санкт-Петербург, ул. Калинина, дом 2, корпус 4, литера А.